

## TSM101 USED IN A VOLTAGE SUPERVISOR

by S. LAFFONT

This technical note shows how to use the TSM101 integrated circuit to realize a voltage supervisor. An example of realization is given.

### 1 - TSM101 PRESENTATION

The TSM101 integrated circuit incorporates a high stability series band gap voltage reference, two ORed operational amplifiers and a current source (Figure 1).

**Figure 1 :** TSM101 Schematic Diagram

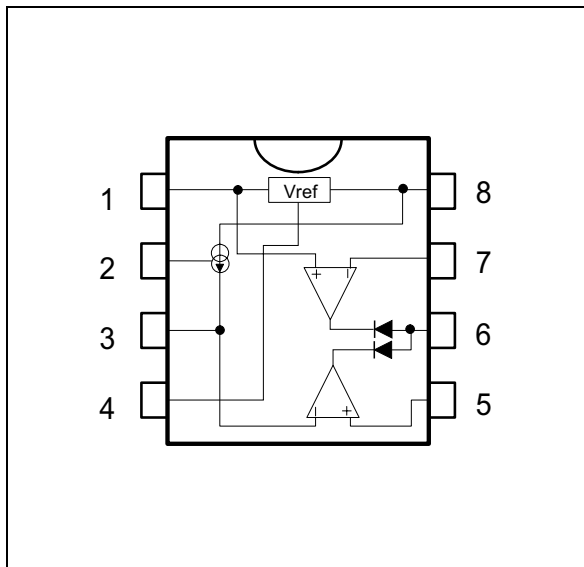

### 2 - PRINCIPLE OF OPERATION AND SCHEMATIC DIAGRAM

The two operational amplifiers are used as comparators.

The first operator has its + input wired to the internal 1.24V reference and the second one its - input wired to 1.24V.

As the two operators are OR-ed internally, the output (pin 6) is low if :

- the negative input (V7) of the first operator (pin 7) is higher than 1.24V

- the positive input (V5) of the second operator (pin 5) is lower than 1.24V.

A resistor network (R1, R2, R3) is used to bias the input of the two operators, when the input voltage is out of the limits, the output (pin 6) is close to zero.

This signal can be used directly to power an optocoupler.

In our application, we have added a transistor (Q1). This transistor is driven via a Zener diode (D1).

This circuit has two advantages :

1 - this Zener diode avoids problems encountered with many voltage supervisors : when the supply voltage is lower than the operating voltage of those circuits, the behavior is erratic.

The minimum operating voltage of the TSM101 is 5V. With a 4.7V Zener diode, the transistor Q1 will never be saturated if the supply voltage is lower than 5V whatever the output of the TSM101.

2 - the optocoupler is ON only if the input voltage is inside the specified range.

### 3 - CALCULATION OF THE ELEMENTS

Let assume :

- $V_{min.}$  = minimum threshold voltage
- $V_{max.}$  = maximum threshold voltage
- $V_{CC}$  = nominal voltage

We have the following equations :

$$V5 = \frac{(V_{min.} \times (R1+R2))}{\Sigma R} = V_{ref}$$

$$V7 = \frac{(V_{max.} \times R1)}{\Sigma R} = V_{ref}$$

$$R1 = \frac{V_{re} \times \Sigma R_f}{V_{max.}}$$

$$R2 = \frac{V_{ref} \times \Sigma R}{V_{min.}} = - R1$$

## APPLICATION NOTE

Example :

Supervision of a 12V  $\pm 5\%$  power supply :

- $V_{min.} = 11.4V$   $V_{max.} = 12.6V$

We take  $R_{\Sigma} = 24k\Omega$  (500 $\mu A$  in the resistor network)

- D1 = 4.7V Zener diode

$I_b(Q1) = 500\mu A$  when ON and a current of 10mA in the opto-coupler when ON

then :

- $R1 = 2.36k\Omega$
- $R2 = 200\Omega$
- $R3 = 21.43k\Omega$
- $R4 = 12k\Omega$
- $R5 = 10k\Omega$
- $R6 = 1k\Omega$

The complete schematic of the voltage supervisor is represented on Figure 2.

**Figure 2** : Voltage Supervisor with TSM101

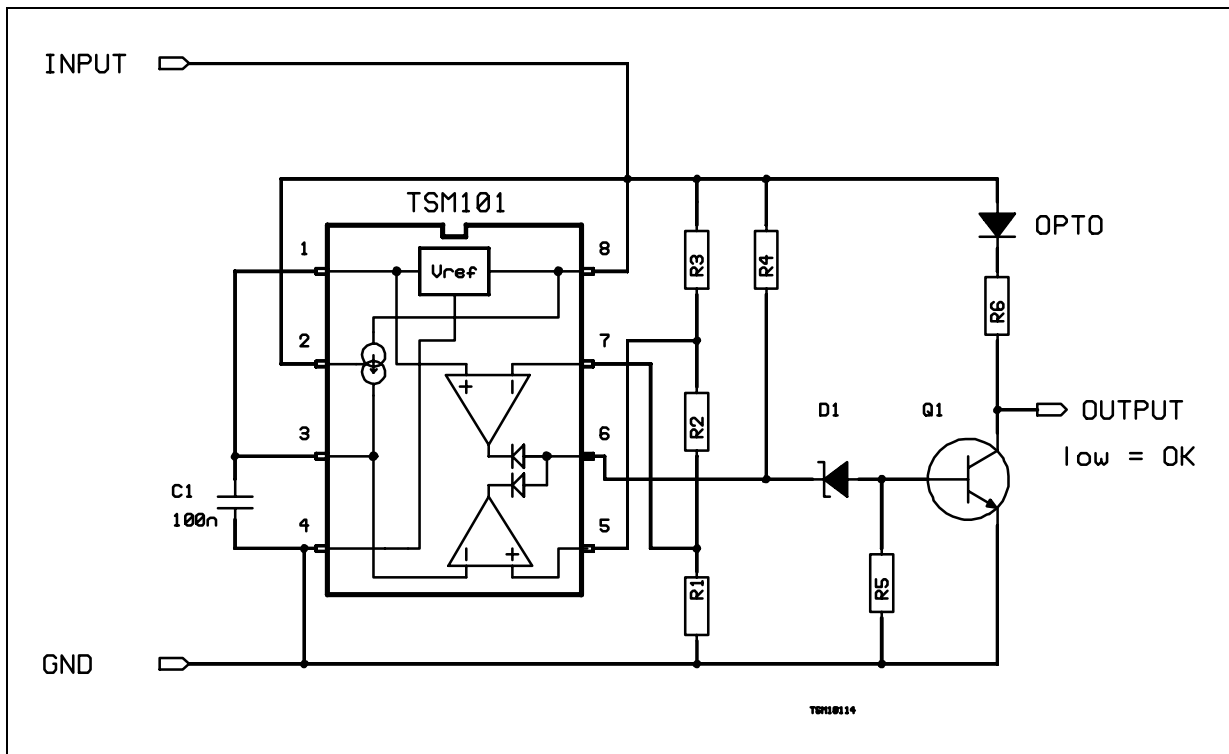

Information furnished is believed to be accurate and reliable. However, STMicroelectronics assumes no responsibility for the consequences of use of such information nor for any infringement of patents or other rights of third parties which may result from its use. No license is granted by implication or otherwise under any patent or patent rights of STMicroelectronics. Specifications mentioned in this publication are subject to change without notice. This publication supersedes and replaces all information previously supplied. STMicroelectronics products are not authorized for use as critical components in life support devices or systems without express written approval of STMicroelectronics.

© The ST logo is a trademark of STMicroelectronics

© 1999 STMicroelectronics – Printed in Italy – All Rights Reserved

STMicroelectronics GROUP OF COMPANIES

Australia - Brazil - Canada - China - France - Germany - Italy - Japan - Korea - Malaysia - Malta - Mexico - Morocco  
The Netherlands - Singapore - Spain - Sweden - Switzerland - Taiwan - Thailand - United Kingdom - U.S.A.

© <http://www.st.com>



LittleDiode supplies new, hard to find or obsolete electronic components and semiconductors all over the world.

With over two million different components listed you are sure to find the part you need.

Feel free to visit us today at our online store:

[LittleDiode.com](http://LittleDiode.com)

Looking forward to providing you with the best possible service.