

AN8816SB

4ch. Linear Driver IC for CD/CD-ROM

■ Overview

The AN8816SB is a 4ch. driver using the power operational amplifier method. It employs the surface mounting type package superior in radiation characteristics.

■ Features

- Wide output D-range is available regardless of reference voltage on the system
- Setting of driver input/output gain enabled by external resistance
- 2ch. independently controllable PC (Power Cut) feature built-in
- Thermal shut down circuit (with hysteresis) built-in
- Proper heat of IC controllable by separating the output supply and setting each independently for 2ch.
- Construction of 5V supply enabled by external PNP Tr
- Accessary operational amplifier built-in
- Relatively easy pattern design by separating and concentrating the input line and output line

■ Application

Actuator for CD/CD-ROM, motor driver

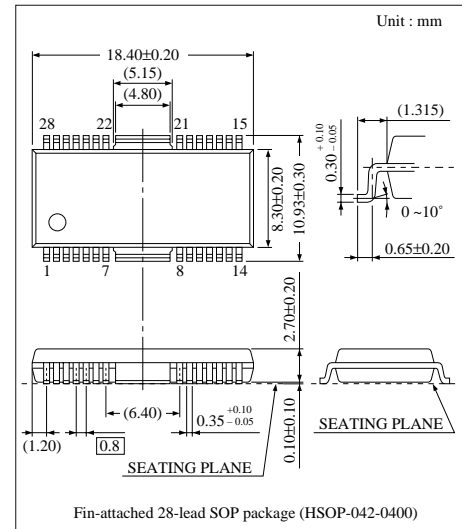

■ Block Diagram

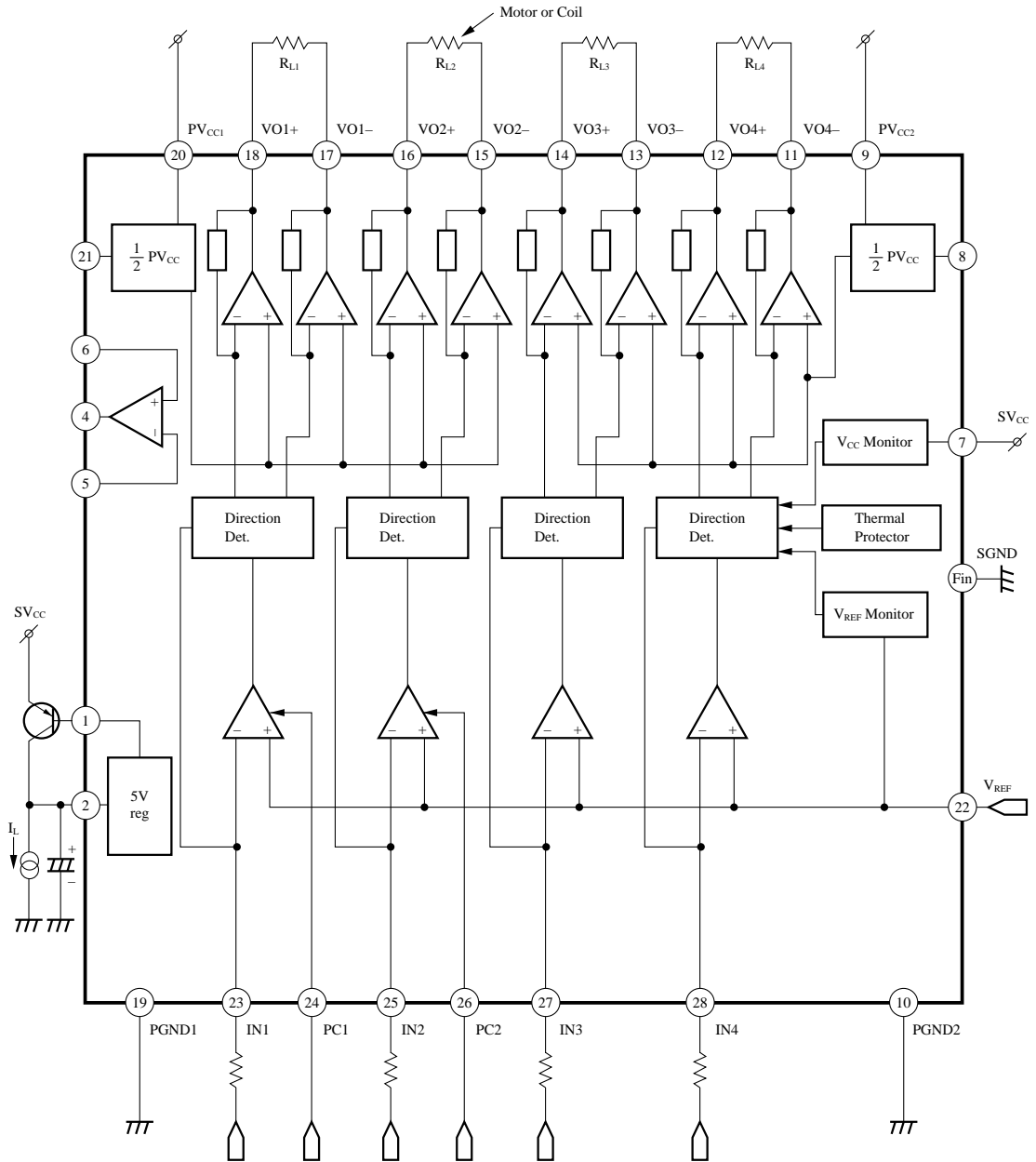

■ Absolute Maximum Ratings (Ta=25°C)

Parameter	Symbol	Rating	Unit
Supply Voltage	V _{CC}	18	V
Supply Current	I _{CC}	—	mA
Power Dissipation ^{Note)}	P _D	3141	mW
Operating Ambient Temperature	T _{opr}	-30 ~ + 85	°C
Storage Temperature	T _{stg}	-55 ~ + 150	°C

Note) For surface mounting on 100 × 80 × 1.6 mm double face glass epoxy board.

■ Recommended Operating Range (Ta=25°C)

Parameter	Symbol	Range
Operating Supply Voltage Range	SV _{CC} ^{Note)}	5.5V ~ 14V
	PV _{CC1} , PV _{CC2}	

Note) Set SV_{CC} to the maximum electric potential.

■ Electrical Characteristics (Ta=25°C)

Parameter	Symbol	Condition	min.	typ.	max.	Unit
Total Circuit Current	I _{tot}	PV _{CC1} = PV _{CC2} = SV _{CC} = 8V	5	10	15	mA

Drivers 1 to 4

Input Offset Voltage	V _{IOF}	PV _{CC1} = PV _{CC2} = SV _{CC} = 8V R _L = 8Ω, R _{IN} = 10kΩ	-10	—	10	mV
Output Offset Voltage	V _{OOV}	PV _{CC1} = PV _{CC2} = SV _{CC} = 8V R _L = 8Ω, R _{IN} = 10kΩ	-50	—	50	mV
Gain	G	PV _{CC1} = PV _{CC2} = SV _{CC} = 8V R _L = 8Ω, R _{IN} = 10kΩ	18	20	22	dB
Maximum Output Amplitude (+)	V _{L+}	PV _{CC1} = PV _{CC2} = SV _{CC} = 8V R _L = 8Ω, R _{IN} = 10kΩ	4.4	5.0	—	V
Maximum Output Amplitude (-)	V _{L-}	PV _{CC1} = PV _{CC2} = SV _{CC} = 8V R _L = 8Ω, R _{IN} = 10kΩ	—	-5.0	-4.4	V
Threshold H	V _{PCH}	PV _{CC1} = PV _{CC2} = SV _{CC} = 8V R _L = 8Ω, R _{IN} = 10kΩ	2.0	—	—	V
Threshold L	V _{PCL}	PV _{CC1} = PV _{CC2} = SV _{CC} = 8V R _L = 8Ω, R _{IN} = 10kΩ	—	—	0.3	V

Reset Circuit

Reset Operation Release Supply Voltage	V _{RST}	I _{IN} = 10μA, R _{IN} = 10kΩ	3.0	3.2	3.3	V
V _{REF} Detection	V _{REF}		2.0	—	—	V

5V Regulator

Output Voltage	V _{REG}	PV _{CC1} = PV _{CC2} = SV _{CC} = 8V	4.75	5.0	5.25	V
Output Load Fluctuation	DV _R	PV _{CC1} = PV _{CC2} = SV _{CC} = 8V	-50	—	50	mV
Supply Voltage Fluctuation	DV _V	PV _{CC1} = PV _{CC2} = SV _{CC} = 8V~12V	-5	—	5	mV

OP Amp.

Input Offset Voltage	V _{OF}	PV _{CC1} = PV _{CC2} = SV _{CC} = 8V	-5	—	5	mV
Input Bias Current	I _{BOP}	PV _{CC1} = PV _{CC2} = SV _{CC} = 8V	—	100	500	nA
High Level Output Voltage	V _{OH}	PV _{CC1} = PV _{CC2} = SV _{CC} = 8V	6.0	—	—	V
Low Level Output Voltage	V _{OL}	PV _{CC1} = PV _{CC2} = SV _{CC} = 8V	—	—	1.7	V
Output Drive Current Sink	I _{SIN}	PV _{CC1} = PV _{CC2} = SV _{CC} = 8V	2.0	—	—	mA
Output Drive Current Source	I _{SOU}	PV _{CC1} = PV _{CC2} = SV _{CC} = 8V	2.0	—	—	mA

Heat Protection Circuit



Operation Temperature Equilibrium Value ^{Note 1)}	T _{THD}		(—)	(180)	(—)	°C
Operation Temperature Hysteresis Width ^{Note 1)}	DT _{THD}		(—)	(45)	(—)	°C

Note 1) Characteristic value in parentheses is a reference value for design but not a guaranteed value.

■ Pin Description

Pin No.	Symbol	I/O	Pin Description	Equivalent Circuit
1	TB	O	Output pin for controlling the power transistor base of 5V	
2	V _{MON}	I	Monitor input pin for 5V regulator output	
4	OPO	O	Output pin of op-amp.	
5	IN-	I	Inverting input pin of op-amp.	
6	IN+	I	Non-inverting input pin of op-amp.	
7	SV _{CC}	—	SV _{CC} pin for driver control circuit, not connected with power V _{CC} pin	

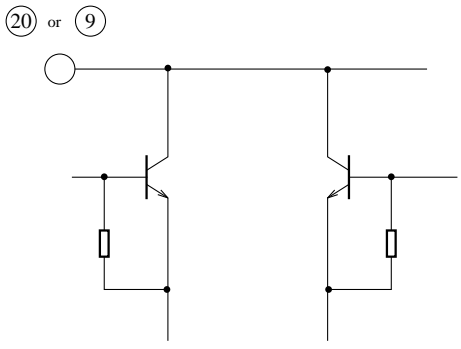
■ Pin Description (Cont.)

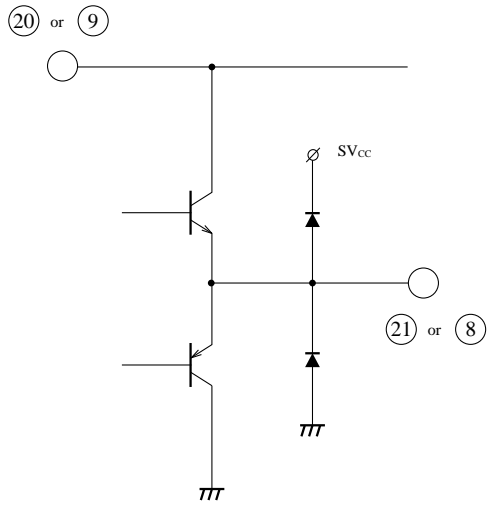
Pin No.	Symbol	I/O	Pin Description	Equivalent Circuit
Fin	SGND	—	SGND pin for driver control circuit	
20	PV _{CC1}	—	Power V _{CC} pin supplying the current flowing in output power transistors, 15, 16, 17, and 18	
9	PV _{CC2}	—	Power V _{CC} pin supplying the current flowing in output power transistors, 11, 12, 13, and 14	
19	PGND1	—	GND pin for output transistors 15, 16, 17, and 18	
10	PGND2	—	GND pin for output transistors 11, 12, 13, and 14	
21	$\frac{1}{2}PV_{CC1}$	O	$\frac{1}{2}PV_{CC}$ output pin 1	
8	$\frac{1}{2}PV_{CC2}$	O	$\frac{1}{2}PV_{CC}$ output pin 2	

■ Pin Description (Cont.)

Pin No.	Symbol	I/O	Pin Description	Equivalent Circuit
22	V _{REF}	I	V _{REF} input pin	
23	IN1	I	Input pin of Driver 1	
25	IN2	I	Input pin of Driver 2	
27	IN3	I	Input pin of Driver 3	
28	IN4	I	Input pin of Driver 4	
24	PC1	I	Power cut input pin of Driver 1	
26	PC2	I	Power cut input pin of Driver 2	
11	VO4-	O	Reverse rotation output pin of Driver 4	
12	VO4+	O	Normal rotation output pin of Driver 4	
13	VO3-	O	Reverse rotation output pin of Driver 3	
14	VO3+	O	Normal rotation output pin of Driver 3	
15	VO2-	O	Reverse rotation output pin of Driver 2	
16	VO2+	O	Normal rotation output pin of Driver 2	
17	VO1-	O	Reverse rotation output pin of driver 1	
18	VO1+	O	Normal rotation output pin of Driver 1	

■ Characteristic Curve

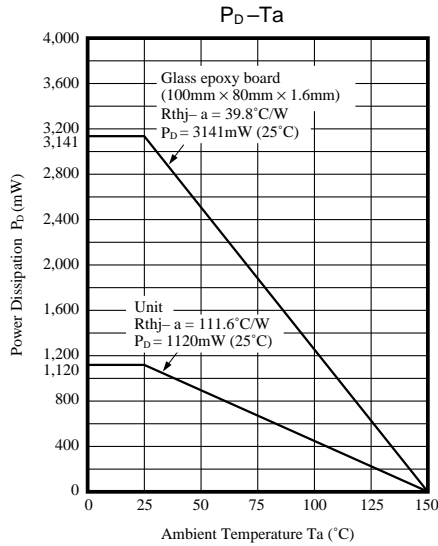

V_{CC} – Maximum Output Amplitude Characteristics

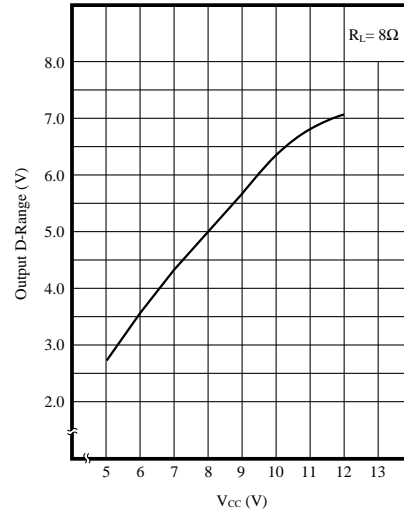

■ Description for use

• Driver Portion

Calculate the driver gain by using the following formula for setting.

$$G = \frac{60k\Omega}{R_{IN1} + 100 (\Omega)} \times 2$$

The power supply for Ch.1 and 2 is supplied from Pin20 and the power supply for Ch.3 and 4 is supplied from Pin9 independently.

Output amplitude is increased by increasing the supply voltage. Set the power supply voltage as necessary. However, always set Pin7 of V_{CC} to the maximum electric potential.

Pin8 and 21 may require a capacitor for ripple removal.

As protection functions, V_{CC} reset circuit, V_{REF} detector and heat protection circuit are incorporated.

The V_{CC} reset circuit operates at approx. 3V and is released at 3.2V, when the supply (Pin7) decreases. For the V_{REF} detector, the protection function works at approx. 1V (max. 2V).

Also, the set temperature for operation of the heat protection circuit is approx. 180°C.

PC (Power Cut) functions which can be independently controlled are incorporated in Ch.1 and 2.

• 5V Supply

By adding an external PNP transistor, 5V regulator can be constructed. Attach an external capacitor for loop filter to output Pin2. In Pin1, the base current limiting circuit (typ. 10mA) is incorporated.

When the V supply is used, the external PNP Tr emitter must be connected to pin than Pin7 (SV_{CC} pin)

• OP Amp.

When the operational amplifier is not used, make connection as follows ;

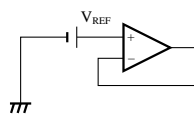

■ Cautions for use

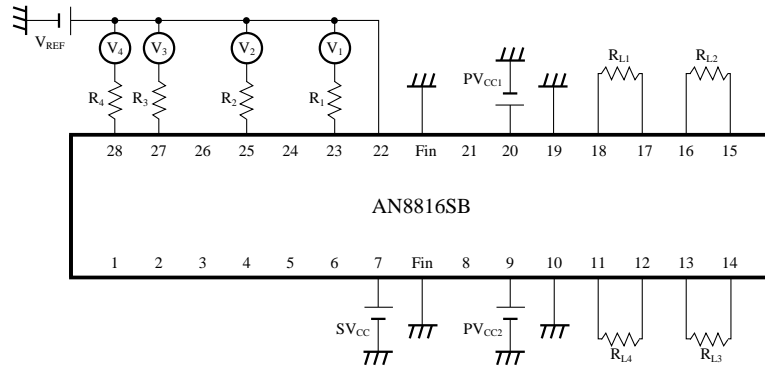

When the AN8816SB is used, take into account the following cautions and follow the power dissipation characteristic curve.

(1) Load current, I_{P1} flowing in loads R_{L1} and R_{L2} is supplied through Pin20.

$$I_{P1} = \frac{|V_{18}-V_{17}|}{R_{L1}} + \frac{|V_{16}-V_{15}|}{R_{L2}}$$

(2) Load current, I_{P2} flowing in loads R_{L3} and R_{L4} is supplied through Pin9.

$$I_{P2} = \frac{|V_{14}-V_{13}|}{R_{L3}} + \frac{|V_{12}-V_{11}|}{R_{L4}}$$

(3) Dissipation increase (DP_d) inside the IC (power output stage) caused by loads R_{L1} , R_{L2} , R_{L3} , R_{L4} is as follow.

$$DP_d = (PV_{CC1} - |V_{18}-V_{17}|) \times \frac{|V_{18}-V_{17}|}{R_{L1}} + (PV_{CC1} - |V_{16}-V_{15}|) \times \frac{|V_{16}-V_{15}|}{R_{L2}} \\ + (PV_{CC2} - |V_{14}-V_{13}|) \times \frac{|V_{14}-V_{13}|}{R_{L3}} + (PV_{CC2} - |V_{12}-V_{11}|) \times \frac{|V_{12}-V_{11}|}{R_{L4}}$$

(4) Dissipation increase (DP_s) inside the IC (signal block supplied from Pin9) caused by loads R_{L1} , R_{L2} , R_{L3} , R_{L4} is almost as follows ;

$$DP_s = 3 \left\{ \frac{V_1}{R_1} (2SV_{CC} + |V_{18}-V_{17}|) + \frac{V_2}{R_2} (2SV_{CC} + |V_{16}-V_{15}|) \right. \\ \left. + \frac{V_3}{R_3} (2SV_{CC} + |V_{14}-V_{13}|) + \frac{V_4}{R_4} (2SV_{CC} + |V_{12}-V_{11}|) \right\}$$

(5) Dissipation increase during driver running is $DP_d + DP_s$.

(6) Inside loss under no load (P_{d1}) is almost as follows ;

$$P_{d1} = SV_{CC} \times I(SV_{CC}) + PV_{CC1} \times I(PV_{CC1}) + PV_{CC2} \times I(PV_{CC2})$$

(7) Entire IC inside loss (P_d) is almost as follows ;

$$P_d = P_{d1} + DP_d + DP_s$$



LittleDiode supplies new, hard to find or obsolete electronic components and semiconductors all over the world.

With over two million different components listed you are sure to find the part you need.

Feel free to visit us today at our online store:

LittleDiode.com

Looking forward to providing you with the best possible service.