

THE L6569: A NEW HIGH VOLTAGE IC DRIVER FOR ELECTRONIC LAMP BALLAST

by G. Calabrese and T. Castagnet

INTRODUCTION

Electronic lamp ballasts are now popular in both consumer and industrial lighting. They offer power saving, flicker free operation and reduced sizes. Improvements to the light control and cost reduction of the ballast will broaden their market acceptance.

Today designers focus on reducing the cost of the ballast, but also work to add features to the ballast like saving energy by dimming the light, or increasing the life time with better preheat and protections. Such requirements have contributed to the development of dedicated high voltage controllers like the L6569, which are able to drive the floating transistor of a symmetric half bridge inverter. This device is a simple, monolithic oscillator-half bridge driver that allows quick design of the ballast.

HIGH VOLTAGE IC DRIVERS IN BALLAST APPLICATIONS

The voltage fed half bridge

Voltage fed series resonant half bridge inverters are currently used for Compact Fluorescent Lamp ballasts (CFL), for Halogen Lamp transformers, and for many European Tube Lamp (TL) ballasts. This simple converter is preferred for new designs, because it minimizes the off state voltage of the power transistors to the peak line voltage, and requires only one resonant choke. In addition this choke protects the half bridge against short circuits across lamp terminals. However overheating and overcurrent occur during open load operation. The inverter robustness must be improved, or some protections are required.

The half bridge inverter operates in Zero Voltage Switching (ZVS) resonant mode [1], to reduce the transistor switching losses and the electromagnetic interference generated by the output wiring and the lamp.

Fully integrated ballast controllers

By varying the switching frequency, the half bridge inverter is able to modulate the lamp power. However most current designs use a sin-

Figure 1: CFL series resonant half bridge inverter.

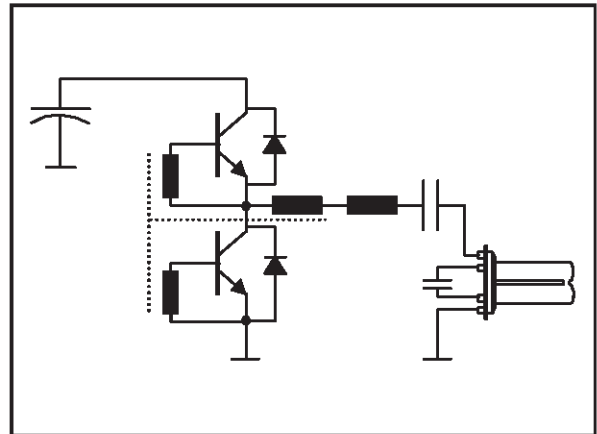
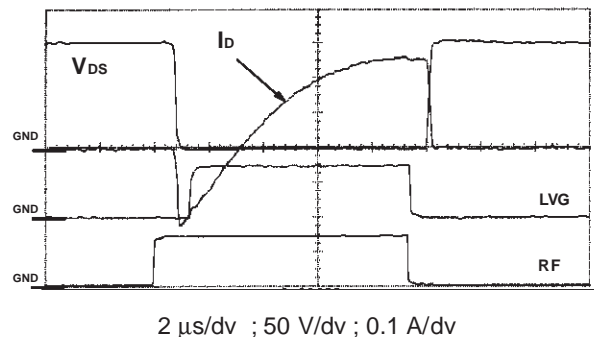

Figure 2: Current and voltage of the STD3NA50 MOSFETs when driven in ZVS with the L6569.



gle frequency with a saturable pulse transformer (see fig. 1) to drive the transistors. This type of design has a higher component count, a higher tolerance on the switching frequency, and it cannot adjust the lamp power.

The only way to design a cost effective, compact and smart control of the lamp is to use a dedicated I.C. that is able to drive the upper transistor of an symmetric half bridge inverter. Such controllers require a high voltage capability for the floating transistor driver [2]. MOSFETs are preferred over Bipolar transistors as power switches because their gate driver requires a lower supply current and a smaller silicon size [3].

AN880 APPLICATION NOTE

THE L6569 AND ITS APPLICATIONS

The L6569

The L6569 is able to directly control a symmetric half bridge inverter of a fluorescent lamp ballast, or a low voltage halogen lamp transformer. Two 270mA buffers drive the inverter MOSFETs in complementary fashion with a 1.25µs built-in dead time to prevent cross conduction. The buffer for the upper Mosfet is driven through a 600V level shifter realized in BCD off line technology. The oscillator, similar to a CMOS 555 timer, operates from 25 to 150 kHz with a +/-5% maximum tolerance. The internal 15V shunt regulator has a 9V Under Voltage Lock Out with an 1V hysteresis,

and the circuit requires only 150 µA at power up.

The L6569 integrates a high voltage Lateral DMOS transistor in place of the usual external diode [2] to charge the bootstrap capacitor for the upper buffer. Figure 5 shows DMOS operating as a synchronous rectifier.

The applications

The primary application for the L6569 is the Compact Fluorescent Lamp. With the oscillator, the supply and the Mosfet drivers it is the core of the application, and designers can customize the circuit to their requirements.

Figure 3: Block diagram of the L6569.

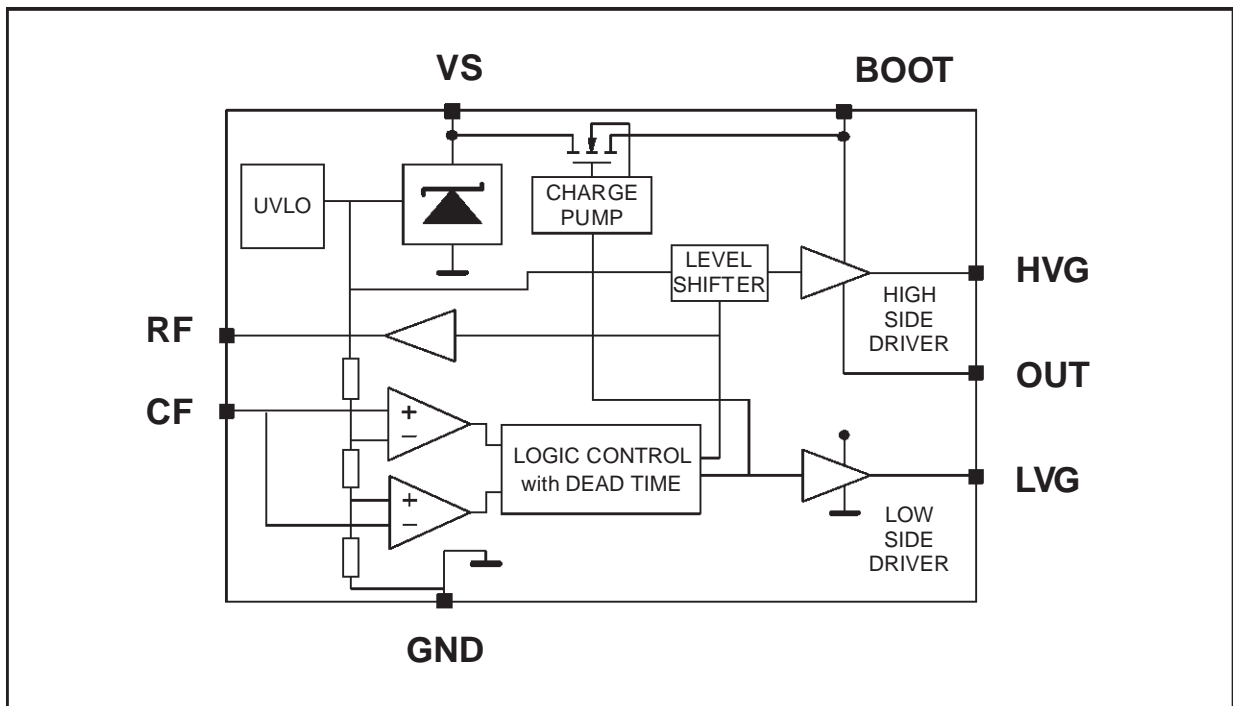

Figure 4: Basic application diagram using the L6569 and two STD4NK50Z MOSFETs.

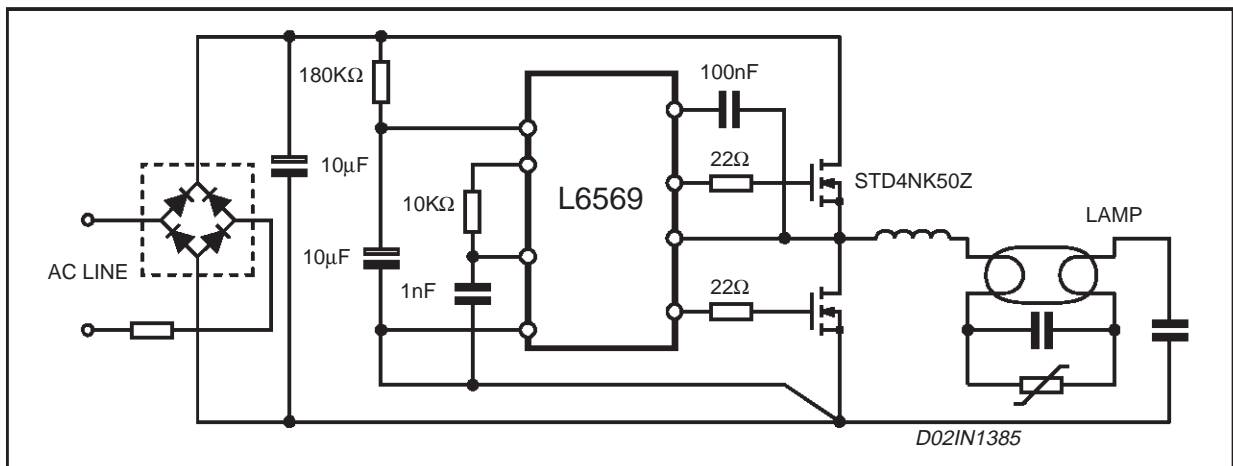

Figure 5: Bootstrap capacitor charge.

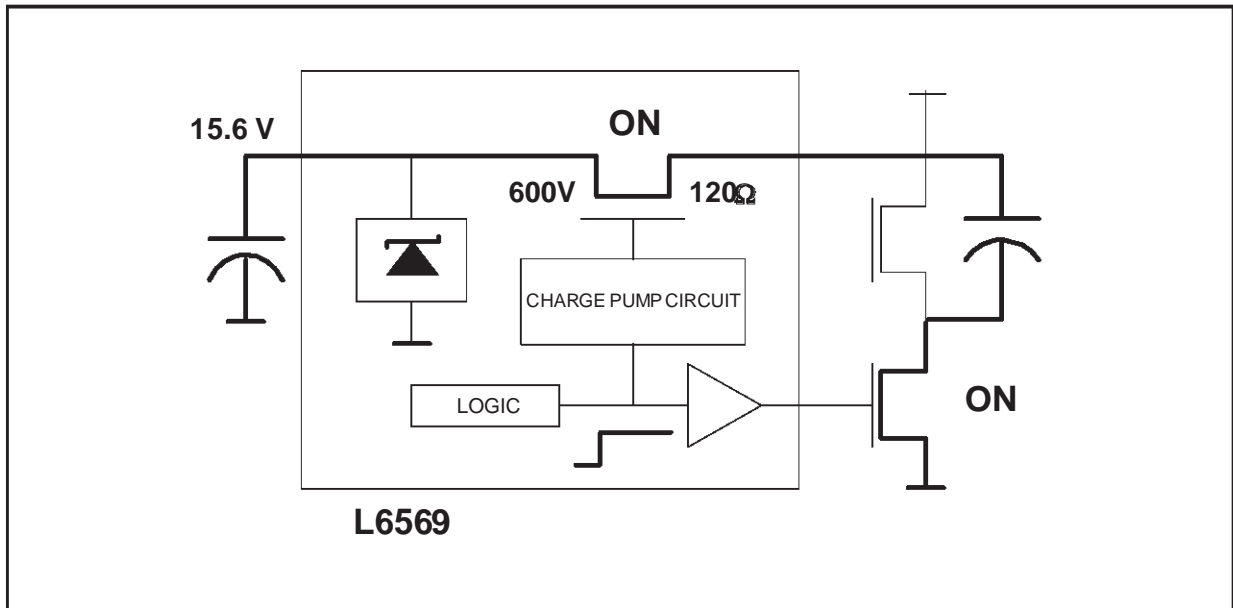
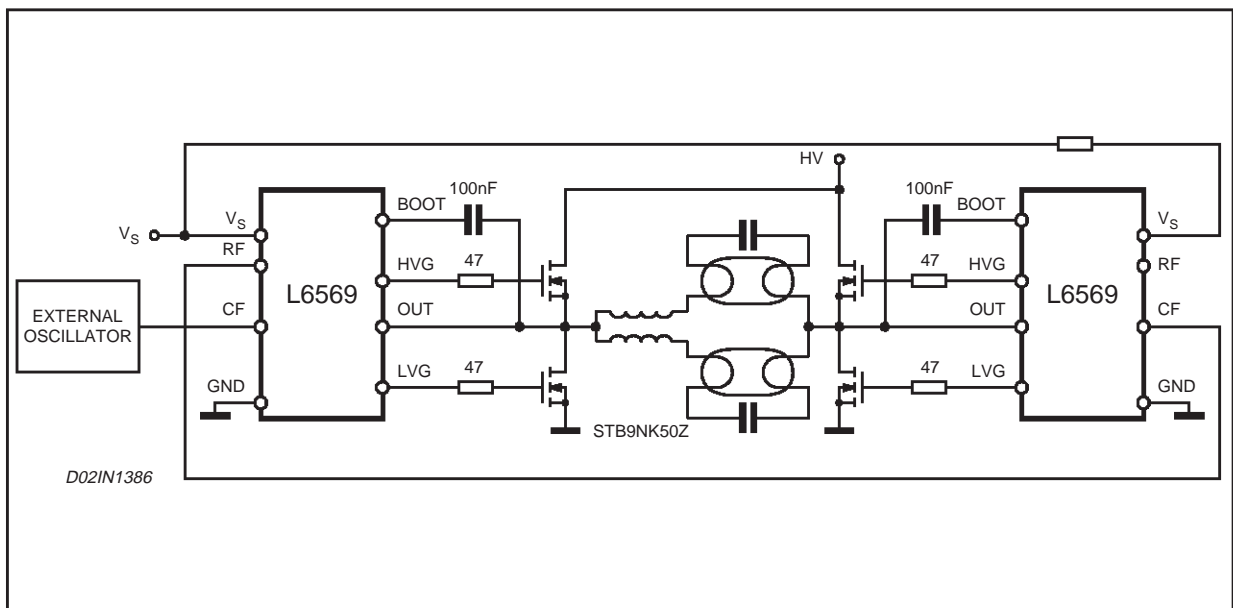

Figure 6: Basic diagram for 2x105 W lamp ballast in full bridge configuration.



Typical industrial TL ballasts requires complex control with dimming or automation interface. Here the L6569 is a driver between the power and control blocks. To use it with an external oscillator, pin CF is used as an 0-12V logic input, and the L6569 becomes a high voltage buffer. Applications with power above 150W require a full bridge inverter. Figure 6 shows how two L6569 drive such a MOSFET bridge. If no external control is required, the first L6569 master can control the switching with its oscillator, and synchronizes the other driver as (slave).

The L6569 start up

Two versions of the L6569 are available with different start up characteristics. The L6569 drives the lower MOSFET ON at power-up until the supply voltage reaches the Under Voltage Lock Out. The bootstrap capacitor is precharged to 4.6V and both the lower and the upper MOSFETs will switch immediately with the oscillator. This is intended for inverters which use only one DC blocking capacitor connected to the power ground, as shown on figure 4 for CFL ballast.

AN880 APPLICATION NOTE

The L6569A holds both MOSFETs OFF until the Under Voltage Lock Out is reached. This is intended for inverters using 2 decoupling capacitors in half bridge as shown on figure 12. The inverter is totally off, so that the voltage at the capacitors center node is not unbalanced by the leakage path during power on.

CONSIDERATIONS ON THE L6569 ENVIRONMENT

To illustrate the benefits of the L6569 in the CFL applications, a demonstration board was developed to supply Sylvania 18W DULUX lamp (ref: CF18DT/E). The following chapters summarize the application considerations applied in this design. The schematic, lay out and components list are shown in appendix A.

Symmetric half bridge operation

To supply a fluorescent lamp, the ballast has to achieve 3 functions: pre heat, ignition, and normal lamp operation. The serial resonance occurs between the choke and the capacitor in parallel with the lamp. The choice of these components determines the lamp ignition voltage and the nominal lamp current.

Since the inverter using the L6569 and MOSFETs can operate at a higher frequency than conventional solutions, the size of the passive components will be reduced. Such inverter can operate up to 150 kHz in ZVS mode, and the switching losses of the power transistors only limits the frequency. In new design this frequency should be set between 50 and 100 kHz. For instance with an 18W lamp, a frequency increase from 33 to 50 kHz will lead to a 40% reduction of the choke size.

To operate in Zero Voltage Switching (ZVS), the switching frequency is higher than the resonant frequency. All operation phases of the ballast are secure in this mode. When the bootstrap transistor is conducting, no pulse current will flow from pin BOOT to pin V_S , as it might happen in Zero Current Switching. The bootstrap transistor remains in its Safe Operating Area, and its dissipation is negligible.

The MOSFET drive

The ZVS drive technique requires only a fast turn off capability as shown on figure 2, and the transistor buffers are designed with a stronger sink current. The two MOSFET buffers of the L6569 can sink a 400 mA peak current on capacitive load. Typically these buffers can drive any MOSFETs in TO220 package.

Figure 7 shows an example with the STP8NA50 that has an 0.85Ω resistance R_{DS-ON} .

Figure 7: Current and voltage of the STP8NA50 MOSFET at turn off with the L6569.

$T_{GD} = 245 \text{ ns}$, $T_c = 95 \text{ ns}$, $E = 93 \mu\text{J}$
@ $T_j = 50^\circ\text{C}$, $R_G = 22 \Omega$.

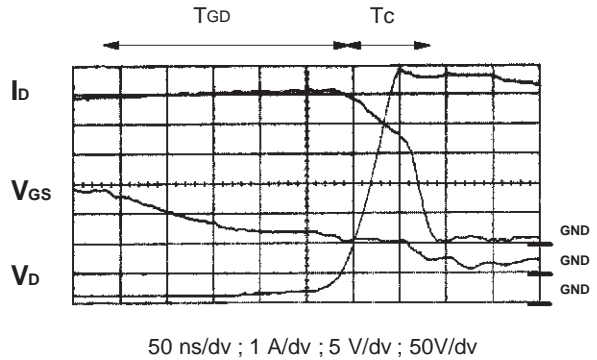

The built-in dead time circuit acts when a MOSFET turns off, delaying the turn on of the opposite transistor for $1.25 \mu\text{s}$. The voltage V_{OUT} between the 2 MOSFETs must switch within the minimum dead time ($0.85 \mu\text{s}$), as shown on figure 8, to avoid bridge cross conductions and transistors overheat.

Figure 8: STD3NA50 MOSFET turn off when driven by the L6569. $T_c + T_{GD} < T_D$

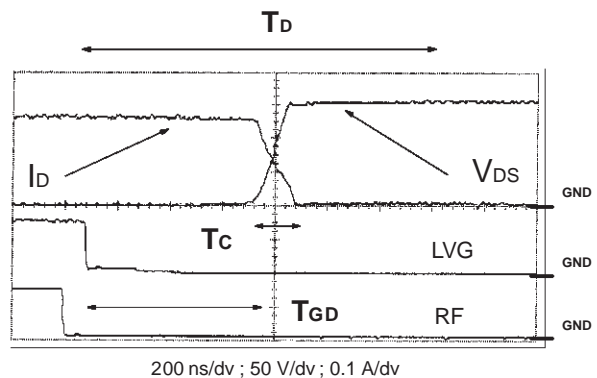

The MOSFET voltage selection

Since the ballast is connected to the ac mains, it must handle any spurious voltage spikes. When the front end RFI filter and the clamping device, such as a varistor, absorbs totally the spike energy, MOSFETs can have the same 600V minimum breakdown voltage BV_{DSS} as the L6569.

Otherwise when the upper MOSFET is on, the residual default may be applied to the L6569. Although the pin OUT breakdown voltage is higher than 600V, it has a poor avalanche robustness. Therefore the lower MOSFET protects the driver by having a lower BV_{DSS} . A MOSFET with a minimum BV_{DSS} up to 500V will achieve safely this task.

Figure 9. L6569 driver protection against voltage spikes.

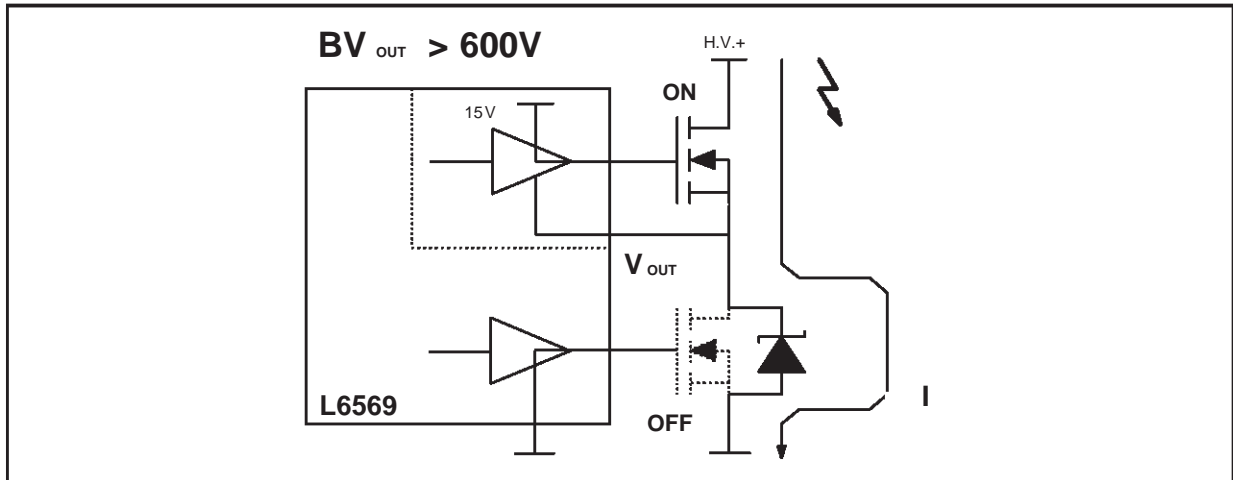

The auxiliary supply of the converter

The circuit consumption is defined by the MOSFETs gate charge, the I.C. consumption, the oscillator, and the shunt regulator. Several circuits are possible.

In many applications a snubber is used to reduce the dissipation in the MOSFETs. When this snubber is used in conjunction with a start up resistor (R_s in Figure 10), a non dissipative supply is achieved almost for free.

At start up the I.C. is consuming 150 µA, and therefore only a small supply resistor is required. During operation the capacitor provides the supply current. To avoid cross conduction, the capacitance is limited by the driver dead time T_D. Hence the capacitive supply current I_c is also limited. For a CFL ballast this circuit easily supplies the required operating current. Using a CF18DT lamp (I_L > 230 mA) the required capacitance is 470 pF on 230 Vac line. At 50 kHz the average capacitive current is 6 mA, as described in appendix B.

When the required driver current is higher than 10

mA, a secondary winding on the resonant choke is an easy supply alternative.

The ballast shutdown

The L6569 allows several ways (see figg. 11, 12 and 13) to shutdown the ballast [4]: by acting on the C_F input oscillator pin to turn off the upper MOSFET or by acting on the V_S supply pin with the Under Voltage Lock Out.

Acting on C_F (Fig. 11) a limiting resistor R_L has to be used, and it has to be: R_L · C_F > 1µs.

When the shutdown is realized acting on V_s pin, (see fig. 12) a limiting resistor R_s must be used to slow down the discharge of the supply filter C_s. The constant time of the discharge must be greater than 10 periods of the switching frequency:

$$R_s \geq \frac{10}{C_s \cdot f_{sw}}$$

Connecting the C_F pin to ground GND stops the oscillator, and the lower MOSFET will remain ON. Therefore the bootstrap capacitor remains

Figure 10: Non dissipative auxiliary supply using the transistor snubber.

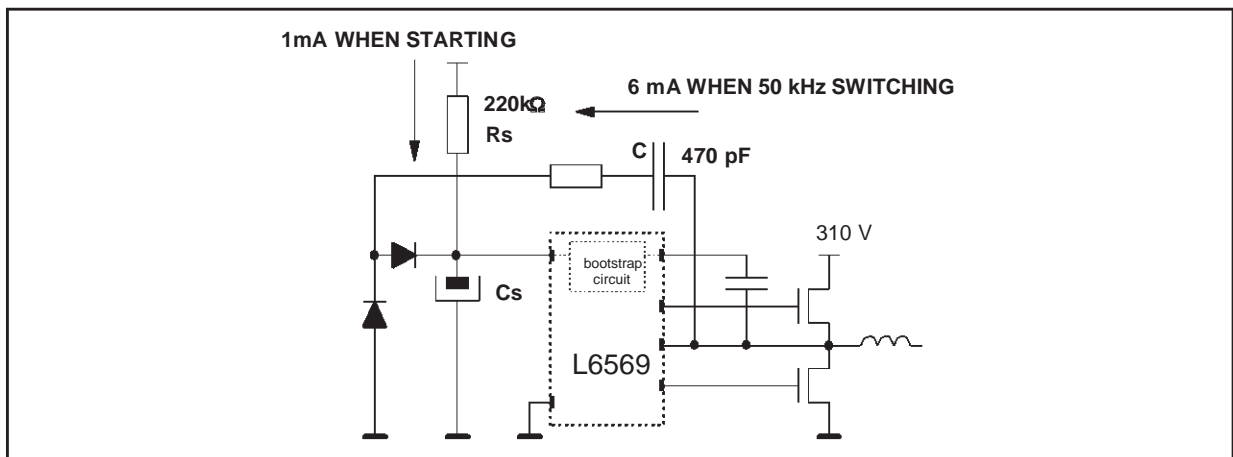

AN880 APPLICATION NOTE

charged and the circuit can restart immediately. This method is suitable when the inverter uses only one DC blocking capacitor connected to the power ground, as used on figure 11 for Compact Fluorescent Lamp. Pulling the V_s voltage below the UVLO turns off the oscillator and gives the same bridge configuration.

For the L6569A, discharging the V_s supply below the UVLO turns off both MOSFETs. An SCR like the X0202MA may be used for the reset function. If the current flowing through the supply resistor is

higher than the SCR holding current (see figure 12), the SCR will remain on and the two MOSFETs off. Removing power or commutating the SCR allows a new start up [4].

Otherwise a disable circuitry that turns off the two MOSFETs (see figure 13), can achieve the shutdown function. Compared to the SCR solution, the shutdown is immediate and the inverter can restart on the disable order.

Figure 11: L6569 shutdown through the C_F oscillator pin.

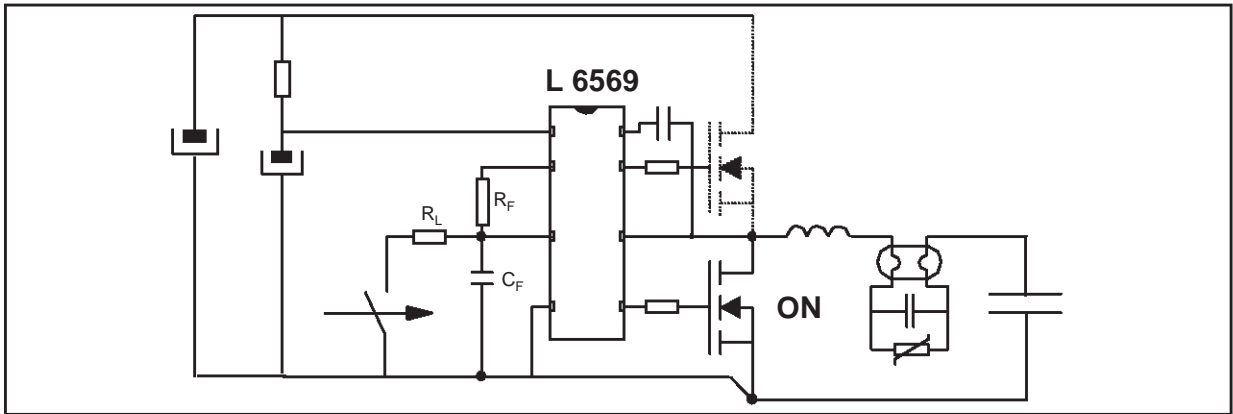

Figure 12: Shutdown with a thyristor & a serial resistor to slow down the supply voltage decay.

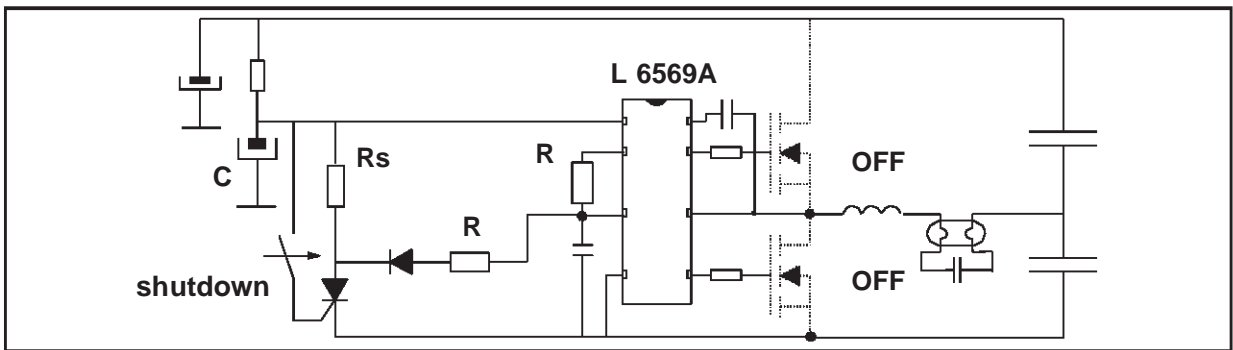
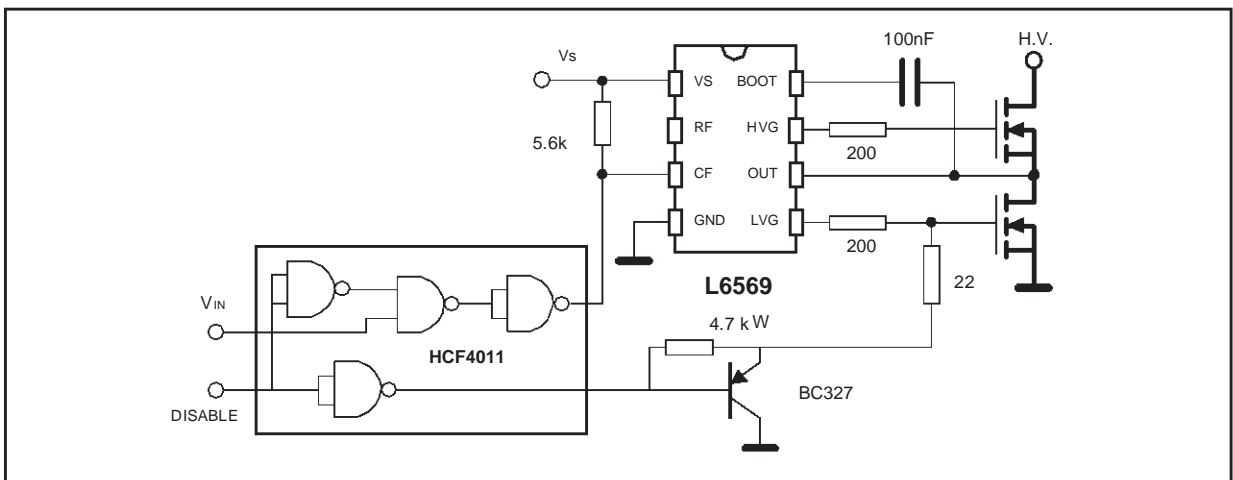

Figure 13: L6569 disable circuitry with both MOSFETs off.



THE LAMP SEEN BY THE ELECTRONIC DESIGNER

The lamp equivalent impedance

The compact fluorescent lamps are specified at 25 kHz (IEC 929). The MOSFETs and the L6569 allow to increase the switching frequency, but the sensitivity of the lamp to the frequency needs to be analyzed.

A few samples of the CF18DT/E lamp were tested by varying the frequency and the current of the lamp. The figure 14 shows the lamp impedance versus its current as it varies from 0.1A to 0.23A with 5 frequencies from 25 to 150 kHz ($T_{AMB} = 25^{\circ}C$).

Figure 14: Variation of the lamp impedance versus its current for several switching frequencies.

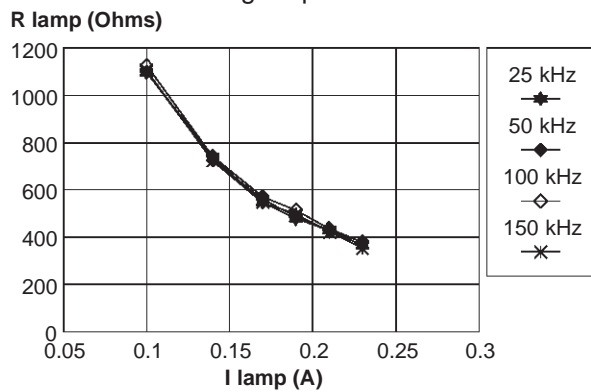

From the tests the impedance appears insensitive to the frequency for such lamps. The specified impedance might be valid for higher frequency operation. The relative lamp light output was measured as proposed in reference [5]. The light flux increases slightly in that frequency range, but can be considered constant.

Obviously the impedance is sensitive to the current with a negative coefficient, and the ballast operates with a non linear impedance [6]. When current is half the nominal one, the impedance is 2.6 times higher, and the voltage is only 25% higher (see figure 15).

Figure 15: Variation of the average impedance and voltage of the lamp

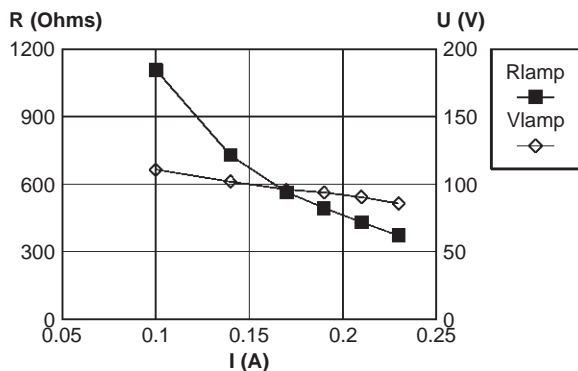

The preheat

Preheat techniques are used in CFL ballasts to reduce the ignition lamp voltage. During this phase the lamp is characterized by a high impedance that forces the electrical conduction through the preheat filaments. These filaments initially have a low resistance that will increase by 5 times during the preheat. The preheat typically lasts from 400 ms to 1 s, and is achieved by controlling either the current or the voltage of the filaments.

For a current control the filaments are in series with the resonant network as shown on figure 16a. When the inverter frequency is constant, a positive temperature coefficient thermistor (PTC) in parallel with the lamp achieves the task by adjusting both the filament current and the preheat duration. The board uses a 150Ω PTC with two 8.2 nF capacitors. The preheat lasts 0.8s and the filament current is 0.45 Arms. The PTC is a cheap device, but it is dissipative and works only once at power-up.

Figure 16: Basic preheat current control diagram (a); preheat filament energy curve (b)

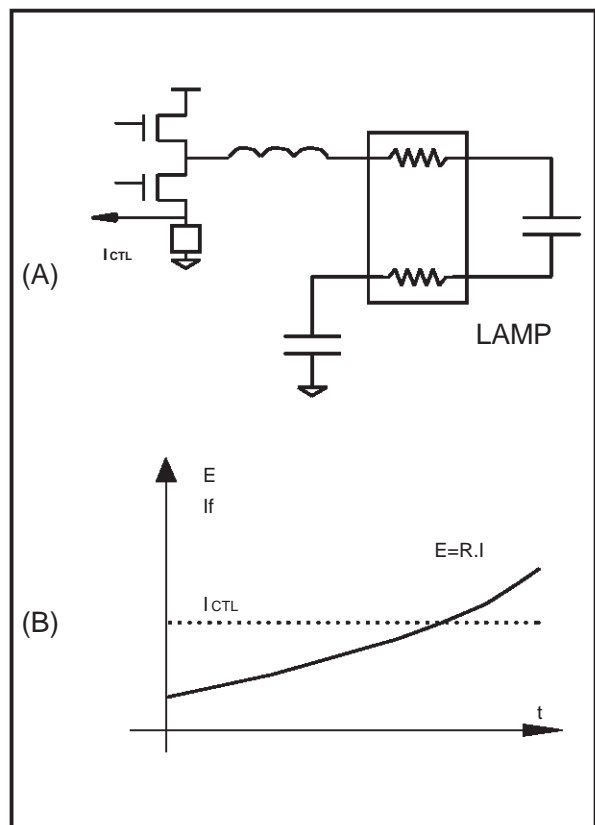

The preheat can be achieved with a filament voltage control. The filaments are supplied by two auxiliary windings of the resonant choke as shown figure 17a. During the preheat the L6569 frequency is increased, and the choke operates

AN880 APPLICATION NOTE

as a transformer supplying the voltage to the filaments. Only few components are added around the L6569 (see figure 18), and the control of the preheat energy is less sensitive to the preheat duration and the inverter frequency (see figure 17b).

The start up initialization

The initial conditions of the power switching start up requires care; especially if the resonant and switching frequencies are close to each other.

The resonant network is not loaded and the full

Figure 17: Basic preheat voltage control diagram (a); preheat filament energy curve (b)

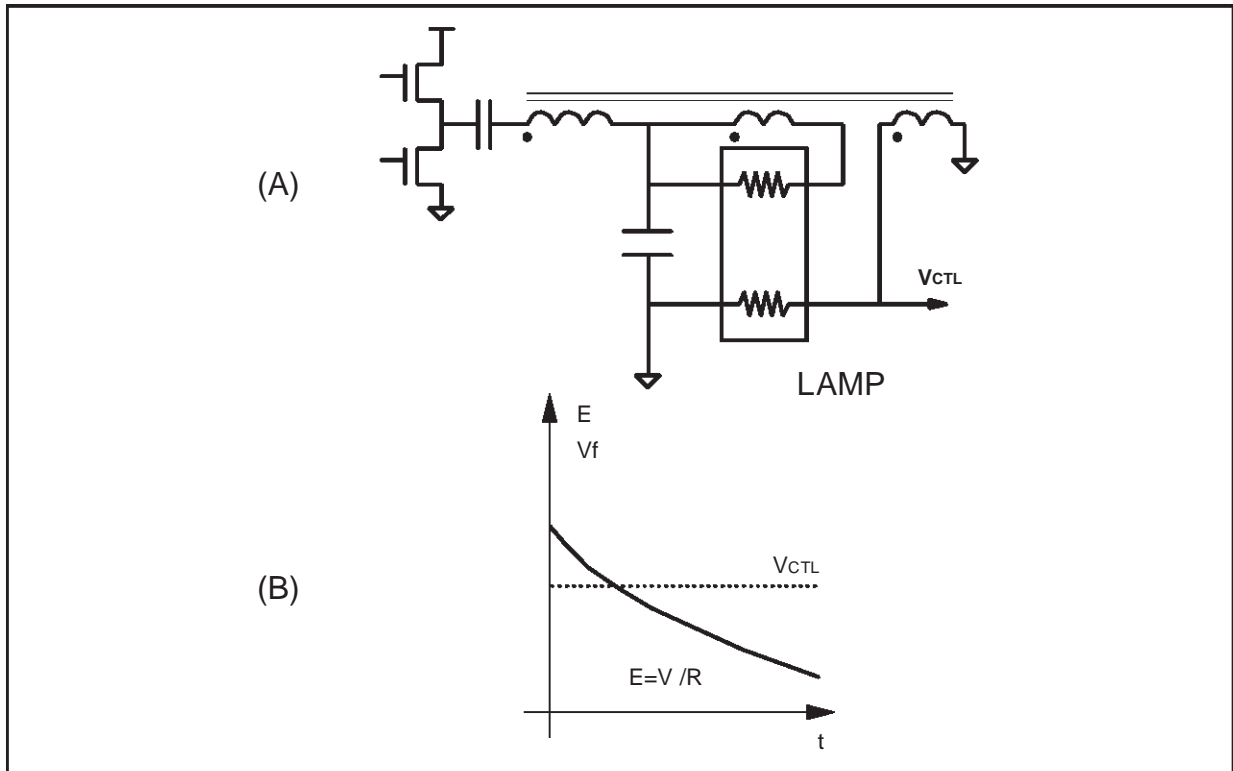
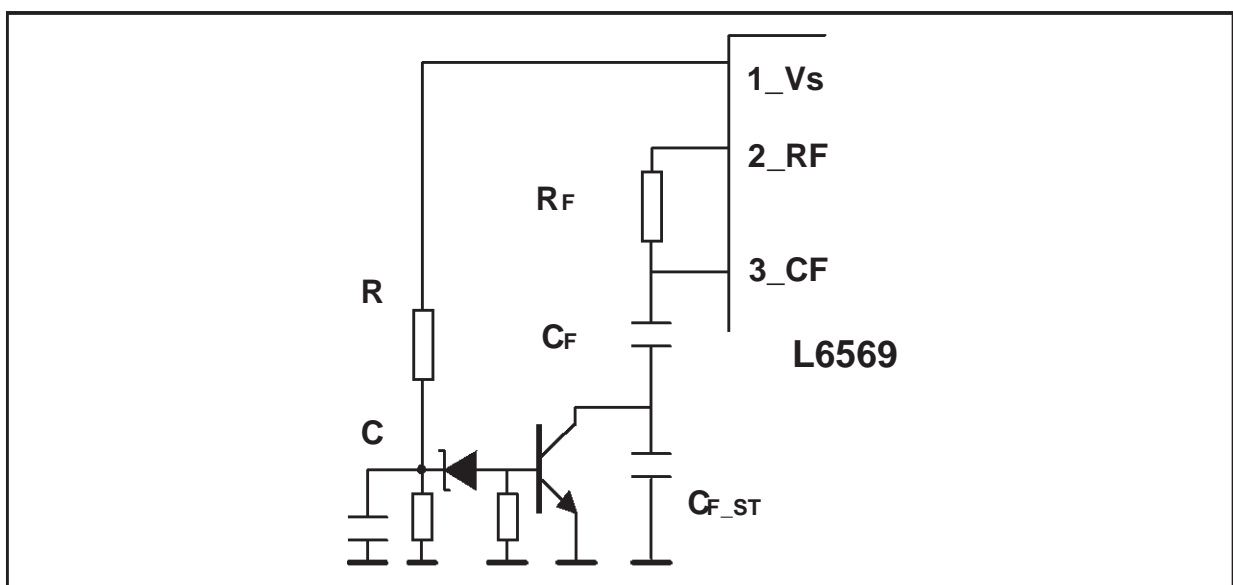

Figure 18: Double frequency control for the L6569 with programmed frequency and duration.



line voltage V_{DC} is applied when the oscillator starts. The ballast has to start directly with its nominal conditions to remove any transient oscillation. Hence the operation runs in ZVS mode with no spurious lamp ignition. This situation does not occur with the saturable transformer drive, because the saturation limits naturally the current by increasing the frequency.

In the example the resonant capacitors are pre-set to be compatible with the choke current rise (see figure 19). The blocking capacitor is pre-charged to approximately half V_{DC} by 2 biasing resistors, and the lower Mosfet also discharges the resonant capacitor to ground (see figure 20). Therefore the blocking capacitor never goes above 2/3 of the line voltage V_{DC} (250V rating), the operation is safe in ZVS mode. The L6569 is here preferred to the L6569A, because the lower

Figure 19: Waveforms of the choke current and the capacitor voltages in steady state preheat.

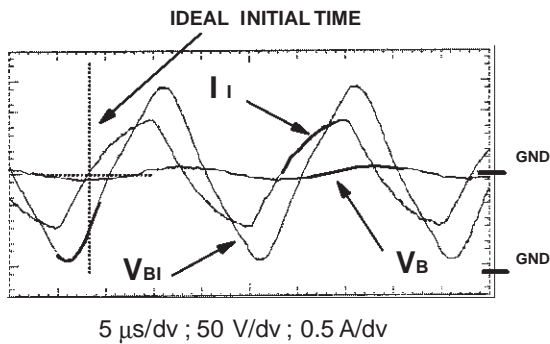

Mosfet is on at power-up.

Figure 20: Configuration of the resonant network during the initialization of the driver.

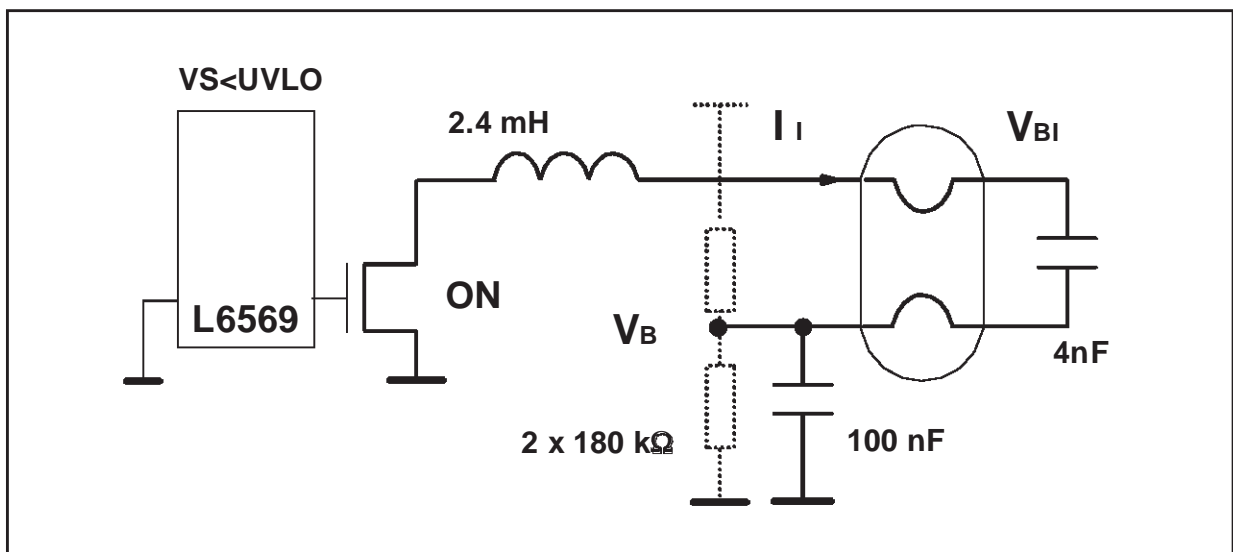

The lamp removal protection

Used in TL ballast, the lamp removal protection is frequently also requested in the "plug-in" CFL ballast. Depending of the topology and the preheat mode, the lamp removal behaves as:

- a no-load resonant mode when the choke and the capacitor are still connected to the inverter ; a required overcurrent protection increases the frequency to reduce the current;
- an open circuit mode when the lamp filaments are inserted in the resonant circuit.

When the circuit is open, the choke is not supplied. The MOSFETs turn off slowly generating bridge cross conduction, and undesirable dissipation losses (see figure 21). The detection stops the switching to eliminate the cross conduction.

Figure 21: Drain current and voltage STP8NA50 MOSFET operating with no-load.

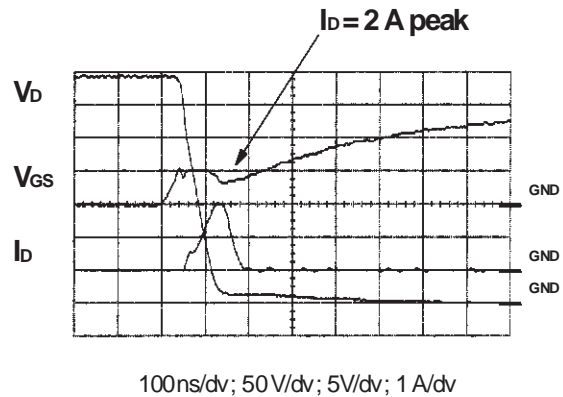

AN880 APPLICATION NOTE

Figure 22: Open load detection example.

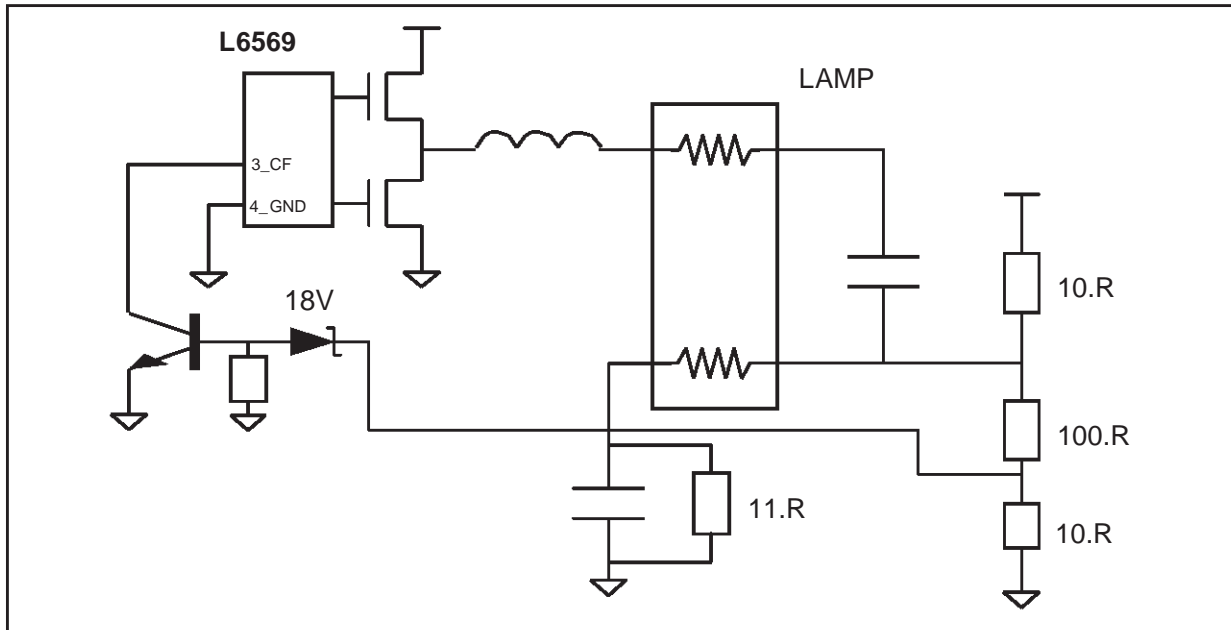

Several ways can achieve the protection task. First it can be done by sensing the resonant current through a MOSFET source resistor or a secondary winding on the choke. The switching is stopped when a large current reduction is detected by analog means.

A logic circuit can also detect the presence of the lamp filaments. One end of a filament is always connected to a fixed voltage. If the other end of the filament is connected through a high impedance resistor to another voltage, the absence of the filament can be easily detected by monitoring the resistor voltage change as shown on figure 22.

CONCLUSION

The foregoing note shows how high voltage drivers, like the L6569, simplify the design of the lamp ballast. These devices includes all the circuitry to drive MOSFETs in half bridge inverter. Since the optimized switching frequency increases above 50 kHz with a low tolerance, the size of the passive resonant components is re-

duced, and the ballast becomes cheaper. With its supply and its oscillator the L6569 is versatile, and its flexibility permits to design any improved power control.

BIBLIOGRAPHY

- [1]: AN 527 "Electronic fluorescent lamp ballast" A.Vitanza, R.Scollo, SGS-THOMSON
- [2]: Smart Power ICs, Chapter 8, High voltage integrated circuits for off-line power applications. C.Diazzi, SGS-THOMSON
- [3]: AN 512 "Characteristics of power semiconductors" JM Peter, SGS-THOMSON
- [4]: "The L6569 half bridge driver: the shutdown function"
- [5]: "Compatibility test of dimming electronic ballasts used in daylighting and environment controls", A.Buddenberg, Rensselaer Polytechnic Institute
- [6]: "PSpice High Frequency Dynamic Fluorescent Lamp Model", Bryce Hesterman, APEC'96, p.641

APPENDIX A: CFL DEMONSTRATION BOARD WITH THE L6569

A demonstration board was developed as an example for Compact Fluorescent Lamp ballast. It is optimised for a CF18DT/E/830 18W lamp from Osram-Sylvania. Using the L6569 the circuit achieves preheat, ignition and normal lamp operation. The power transistors are two STD3NA50 500V-3Ω MOSFETs in I-PACK package.

Board description

The three sections of the board are an AC input rectifier, the half bridge inverter, and the resonant ballast. By changing the connection on the input mains, the ballast can operate either on 120 Vac mains with a voltage doubler rectification, or on 230 Vac mains with a full wave rectification. The input resistor R₁ limits the initial inrush current charging the bulk capacitors. The L6569 operates with a single 50 kHz switching frequency programmed by R₄ and C₁. Two fast diodes D₂ & D₃ synchronize the oscillator to keep the switching in ZVS mode. The control circuit requires 4.5 mA to supply the I.C., the MOS gate drives, and the oscillator. Its supply delivers at least 6.5 mA as described in appendix B. The start up resistor also balances the voltage across the two bulk capacitors.

Figure 23. CFL ballast diagram for a 18W CF18DT/E lamp with 120/230 Vac inputs.

The resonant ballast

The value of the choke (L₁) and the two capacitors (C₇ & C₈) in parallel with the lamp determine the lamp ignition voltage and the nominal lamp current. During the ignition the lamp impedance is essentially infinite, and the filaments resistance is only the serial load. To generate the ignition voltage, the switching frequency is set close to the resonance frequency. In normal operation the choke resonates with the capacitors C₇ & C₈ (parallel loading), but also with the decoupling capacitor C₆ (serial loading). The current mode preheat uses a 150Ω Positive Temperature Coefficient thermistor. Inserted in the capacitive series (C₇ & C₈), the PTC produces a 0.45 Arms filament current during the initial 0.8 s (reference: 307C1253BHEAB from CERA-MITE).

Basic ballast electrical characteristics

- Input voltage: 120 or 230 Vac by input connections change
- Switching frequency: 50kHz
- Average dc line voltage range: V_{dc} from 260 to 355
- Nominal supply current: 0.17A rms @ 310 Vdc
- Nominal output power: 17W
- Minimum ignition voltage: 700V peak @ 260 Vdc
- Nominal preheat current: 0.45 Arms during 0.8s @ 310 Vdc

Figure 23.

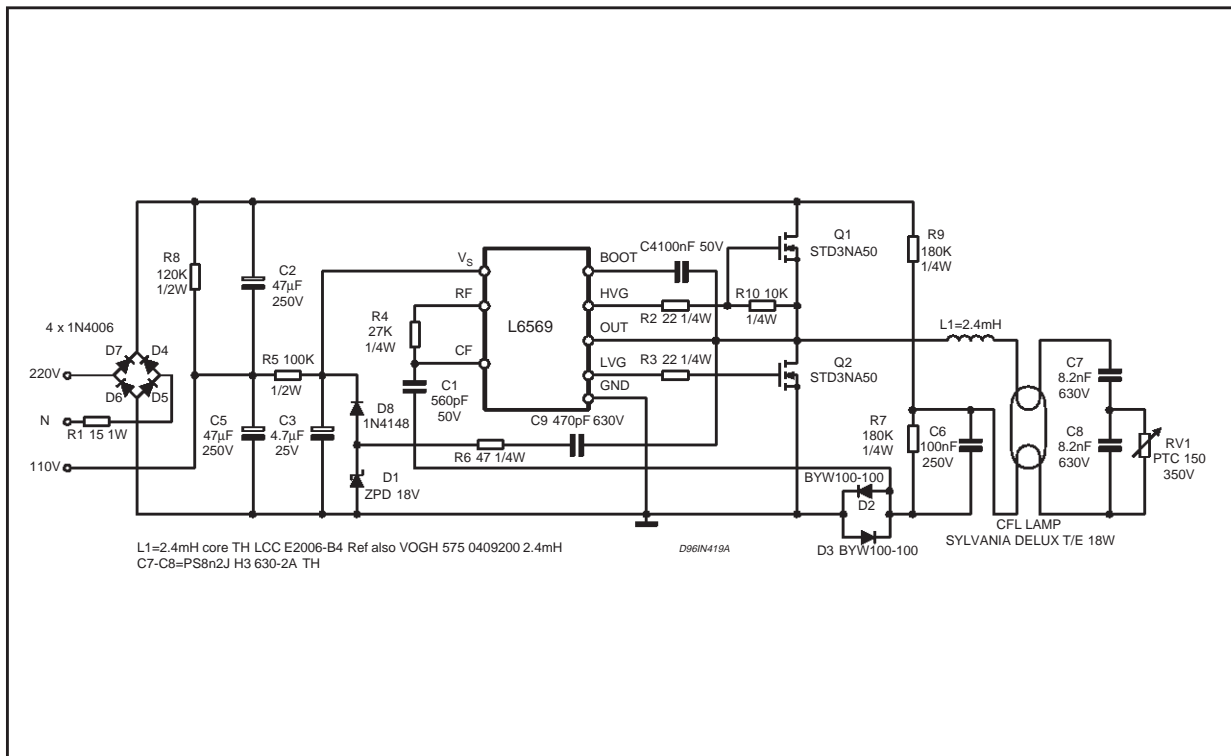

Figure 24: PCB Layout of the board.

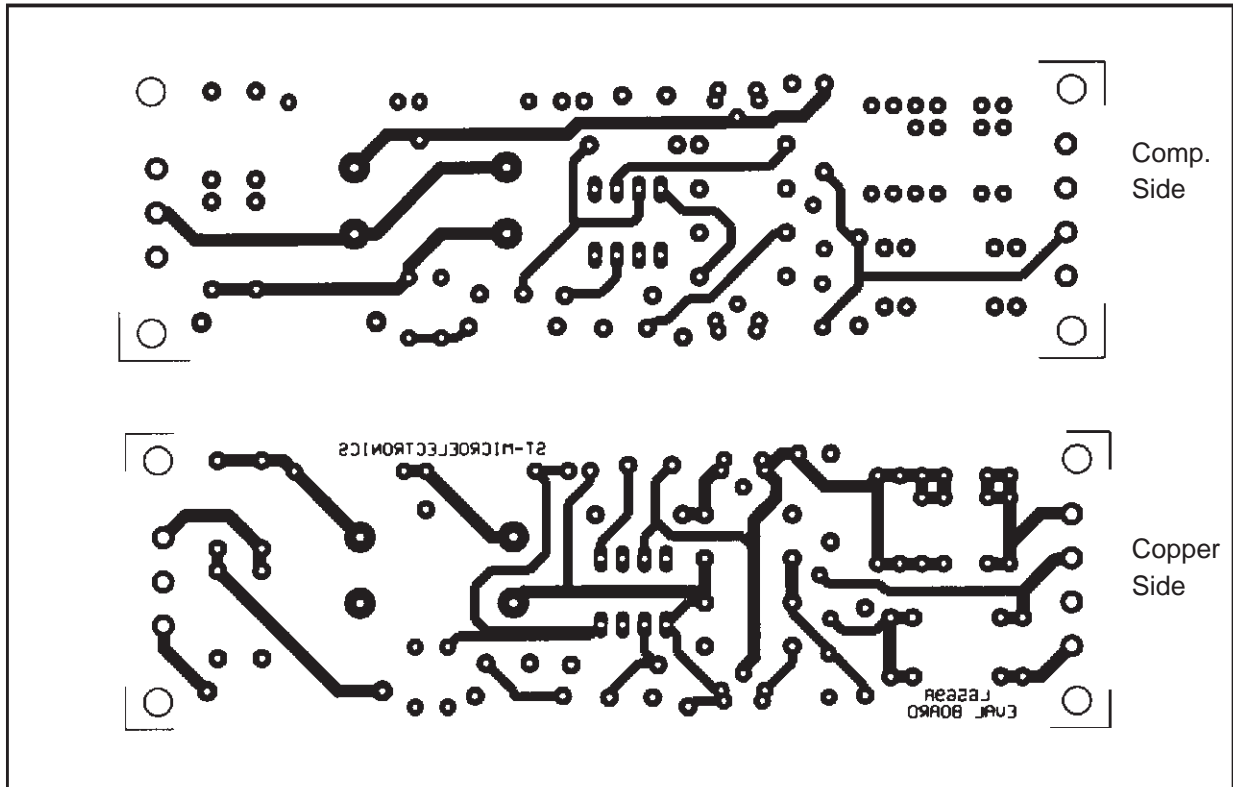
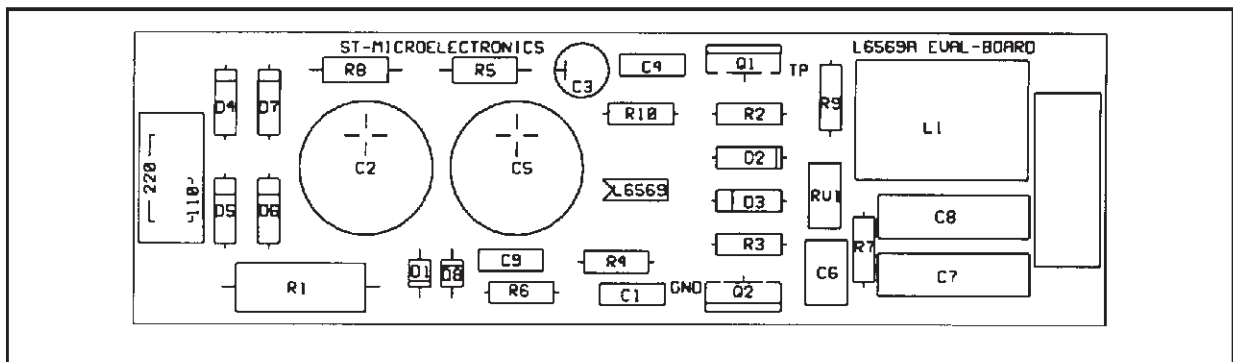

Figure 25: PCB component placement diagram.



The resonant choke

The inductance of the choke is 2.4 mH with a minimum saturation current of 0.65 A. In the practical example it has been done with:

- Core: Thomson LCC E2006 material B4;
- Air gap: 2 spacers of 0.4 mm each (total 0.8 mm);
- AL = 75 nH;
- Bobbin: HC2006BA-06;
- Number of turns: 175;
- Measured saturation current: 1 A peak @ 25 °C;

Customization of the board

Some flexibility is added to the board to extend its evaluation. The MOSFETs have two foot prints to mount either I-PAK or TO220 packages. And two choke footprints are also available for E1905A and E2006A magnetic cores.

APPENDIX B: Rating of the capacitive supply with the L6569 driver

The supply is made with the snubber and a start up resistor R_S .

A snubber circuit is used to minimize the MOSFETs dissipation. It also achieves a non dissipative supply as shown on figure 10.

The MOSFETs gate charge, the driver consumption, the oscillator, and the shunt regulator, define the circuit consumption. We can estimate this current is I_{SAV} :

$$I_{SAV} > 2 \cdot I_G + I_{QS} + I_{OSC} + I_{REG} = 2 \cdot Q_G \cdot f_{sw} + I_{QS} + \frac{V_S}{R_F \cdot 2} + I_{REG}$$

Where Q_G the MOSFET gate charge

I_{QS} the driver supply current

V_S the supply voltage

R_F the oscillator resistor and V_S the driver supply voltage

I_{REG} the shunt regulator current.

When V_S is lower than the UVLO threshold U_{UVLO} , the driver is only consuming. Its current must be minimal to reduce the dissipation of the resistor R_S . The L6569 has a $150 \mu A$ start up current, and the maximum resistance is $2M\Omega$ for a 230Vac line application.

We can also reduce the resistor value to get a faster start up time T_S .

$$T_S = \frac{R_S \cdot C_S \cdot U_{UVLO}}{V_{DC}}$$

Where C_S is the supply capacitor, and V_{DC} the line voltage.

When the timer oscillates, the capacitor C sup-

plies the lamp current during the lower MOS turn off. To avoid any cross conduction its capacitance is limited by the driver dead time T_D (see figure 26). Hence the capacitive supply current I_C is also limited.

$$C < \frac{T_D \cdot I_L}{V_{DC}}$$

$$I_{CAV} = C \cdot V_{DC} \cdot F_{sw} < I_L \cdot T_D \cdot F_{sw}$$

Where I_L is the peak lamp current, and F_{sw} the switching frequency.

For a ballast such as a CFL one this circuit supplies easily the required current. For instance with a CF18DT lamp ($I_L > 230 \text{ mA}$) the capacitor is 1 nF on 120Vac line, 470 pF on 230 Vac line. At 50 kHz the average capacitive current is 6 mA in both cases.

Figure 26: Cross conduction of the snubber capacitor with the upper MOSFET: capacitor current and voltage waveforms.

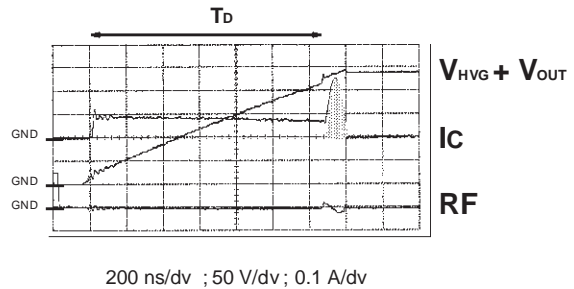

Information furnished is believed to be accurate and reliable. However, STMicroelectronics assumes no responsibility for the consequences of use of such information nor for any infringement of patents or other rights of third parties which may result from its use. No license is granted by implication or otherwise under any patent or patent rights of STMicroelectronics. Specification mentioned in this publication are subject to change without notice. This publication supersedes and replaces all information previously supplied. STMicroelectronics products are not authorized for use as critical components in life support devices or systems without express written approval of STMicroelectronics.

The ST logo is a registered trademark of STMicroelectronics

© 2002 STMicroelectronics – Printed in Italy – All Rights Reserved

STMicroelectronics GROUP OF COMPANIES

Australia - Brazil - Canada - China - Finland - France - Germany - Hong Kong - India - Israel - Italy - Japan - Malaysia - Malta - Morocco -
Singapore - Spain - Sweden - Switzerland - United Kingdom - United States.

<http://www.st.com>



LittleDiode supplies new, hard to find or obsolete electronic components and semiconductors all over the world.

With over two million different components listed you are sure to find the part you need.

Feel free to visit us today at our online store:

LittleDiode.com

Looking forward to providing you with the best possible service.