



Evaluation Circuits for XDCP™

by Applications Staff, June 2000

Introduction

The use of Xicor's nonvolatile digital potentiometers (XDCPs) in mixed signal applications can offer a number of unique system advantages over the use of mechanical potentiometers. During prototyping, a design engineer may want to evaluate these devices in order to see how well they will perform in the intended application. In many cases, a simple circuit to control an XDCPs operation (and which can be "jumpered" into a target system) is sufficient. To that end, this application note features some simple circuit schematics that an engineer can build in order to quickly evaluate any of Xicor's XDCPs.

PushPOTs

The X9511 is a 32-tap, human interface, nonvolatile digital potentiometer with a direct pushbutton interface (i.e. PushPOT). This device provides added flexibility when designing consumer or industrial products which require user control of system parameters (e.g. LCD backlighting and contrast control on laptop computers). The PushPOT interface consists of separate PU and PD pins to control the movement of the wiper (respectively, up or down). Holding either pin LOW for a sufficiently long period of time allows the PushPOT to enter a slow wiper scan mode, which allows multiple wiper transitions without the need to pulse the pin HIGH between transitions. Continuing to hold the pin LOW will eventually initiate a fast wiper scan mode. Both of these pins are debounced and internally pulled-up, allowing for a direct pushbutton interface. The ASE pin (also debounced), when tied LOW during operation, implements a power-down AUTOSTORE™ mode which stores the current wiper position to EEPROM. Alternatively, if this pin is normally HIGH during operation, but pulsed LOW when desired, a manual nonvolatile store

XDCP is a trademark of Xicor, Inc.

cycle can be initiated. The X9514 is a log taper version of the X9511. The circuit in Figure 1 can be used to evaluate these devices.

2-Wire Serial Interface XDCPs

Xicor's dual and quad XDCPs are available with an industry standard 2-wire serial interface. The X9221 is a dual 64-tap device and the X9241 is a quad 64-tap device. Among other features, additional EEPROM registers are contained within each device to allow for greater system flexibility (i.e. in order to store multiple wiper positions which can be recalled via software or to serve as a small amount of scratch nonvolatile memory for the system). The X9241 also allows for adjacent potentiometers to be internally cascaded, enabling the creation of a 256-tap potentiometer with only 3 redundant tap positions. The circuit in Figure 2 can be used to evaluate these devices.

3-Wire XDCPs

A more traditional 3-wire interface, consisting of chip select (CS), increment (INC), and directional (U/D) pins, can be found on the X9CMME, X9312, X9313, and X9314. The X9CMME (aka X9C102/103/104/503) has 100 taps and a tolerance on VH and VL of between -5V and +5V with respect to the V_{SS} pin voltage. This is standard for all of Xicor's XDCPs, except for the X9312 which allows for any voltage between 0V and +15V (with respect to its V_{SS} pin voltage) to be applied to VH or VL. The X9CMME and X9312 have 100 taps, while the X9313 and X9314 have 32 taps. The X9314 is a log taper version of the X9313. The circuit in Figure 3 can be used to evaluate these devices.

Table 1: XDCP Device Summary

Part No.	VH & VL Range	Tap Positions	End-to End Resistance (W)	V _{CC}	Packages ^[1]	Comments
X9CMME	±5V	100	1K, 10K, 50K, 100K	3V - 5.5V	S8	
X9312	0V to 15V	100	1K, 10K, 50K, 100K	4.5V - 5.5V	S8	
X9313	±5V	32	1K, 10K, 50K, 100K	3V - 5.5V	S8 M8	
X9314	±5V	32	10K	3V - 5.5V	S8 M8	log taper
X9511	±5V	32	1K, 10K	4.5V - 5.5V	S8	PushPOT
X9221	±5V	64 (dual)	2K, 10K, 50K	4.5V - 5.5V	S20	2-wire compatible, cascadeable
X9241	±5V	64 (quad)	2K, 10K, 50K	4.5V - 5.5V	S20 V20	2-wire compatible, cascadeable

1. Package code: S=SOIC, M=MSOP, V=TSSOP, and the number indicates the number of pins/leads. Xicor package codes do not usually contain the pin/lead count so these abbreviations should not be used when ordering parts

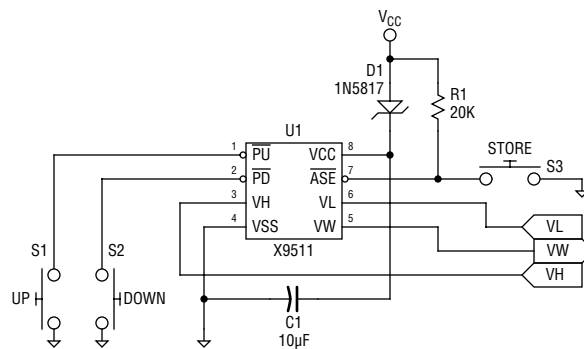
Figure 1. PushPOT evaluation circuit (with external AUTOSTORE circuitry).

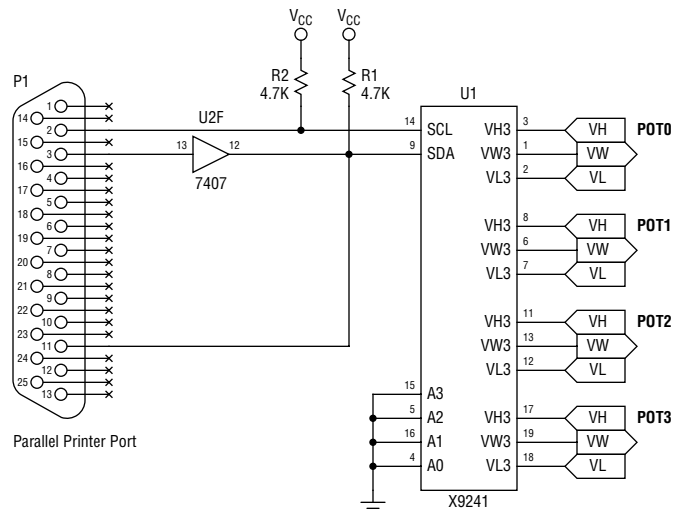

Figure 2. X9221/X9241 Evaluation Circuit

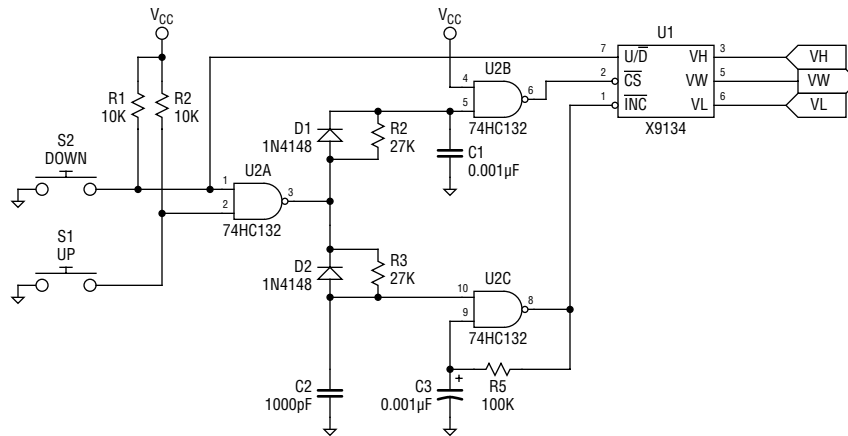

Figure 3. Simple 3-Wire XDCP Evaluation Circuit



LittleDiode supplies new, hard to find or obsolete electronic components and semiconductors all over the world.

With over two million different components listed you are sure to find the part you need.

Feel free to visit us today at our online store:

LittleDiode.com

Looking forward to providing you with the best possible service.