

**TURBOSWITCH™ IN AN
ASYNCHRONOUS MOTOR DRIVE**

B.Rivet

The basic schematic of an asynchronous motor drive is shown in fig.1

Fig.1 : Basic schematic of an asynchronous motor drive.

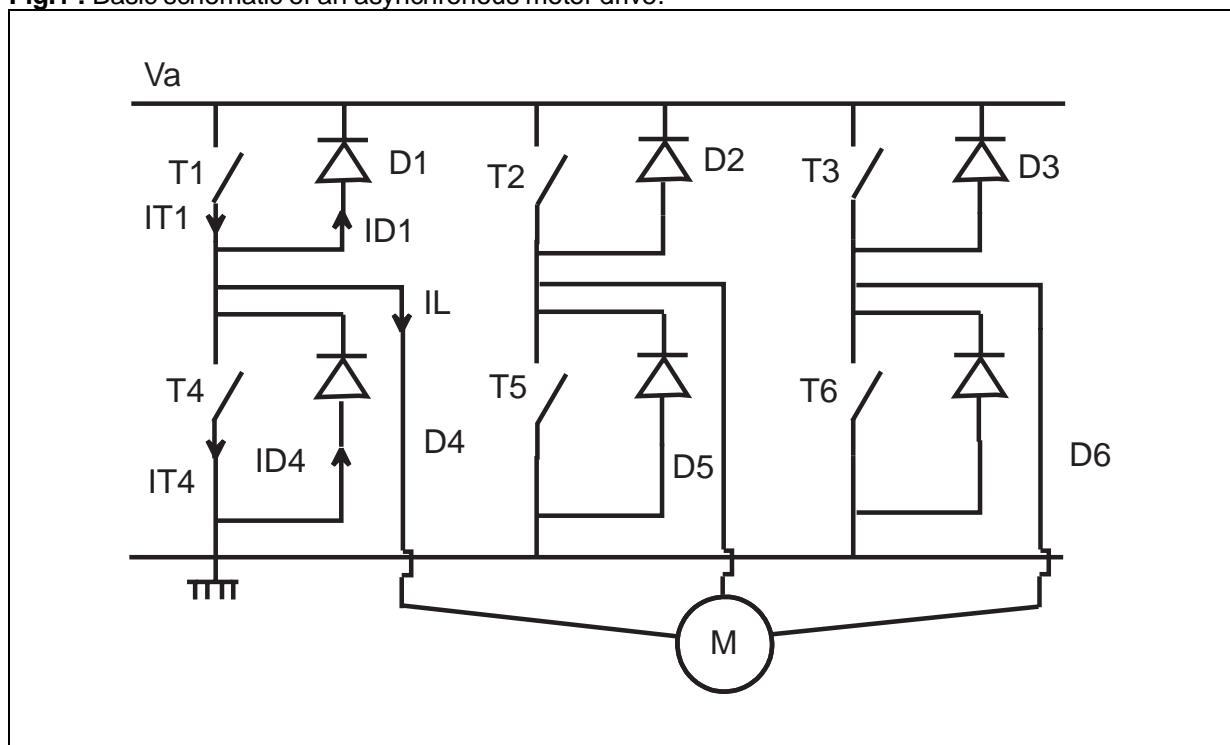

The positive sinusoidal current I_L is built with the commutation of T1 and the complementary freewheel diode D4, whereas the negative sinusoidal part is built with T4 and D1 (Fig.2).

Switching losses (Turn-ON and Turn-OFF) in the diode are negligible with regard to conduction losses.

The average current in the diode can be estimated by making the hypothesis (with a big safety margine) that the current in the diode is a half sine wave (Fig.2). This hypothesis is valid when the motor works in braking mode.

With this hypothesis we find :

$$I_{F(AV)} = 0.43 \frac{P}{V_a \cos \varphi} \quad (1)$$

Example : $P=1\text{kVA}$ $V_a=400\text{V}$ $\cos\varphi = 0.95$

$$\rightarrow I_{F(AV)} = 1.1\text{A}$$

Even with this pessimistic hypothesis, we find the average current in each diode is low ($< 1.1\text{A}$ for a 1kVA motor).

APPLICATION NOTE

Fig. 2 : Current waveform in T1, D1, T4 ,D4

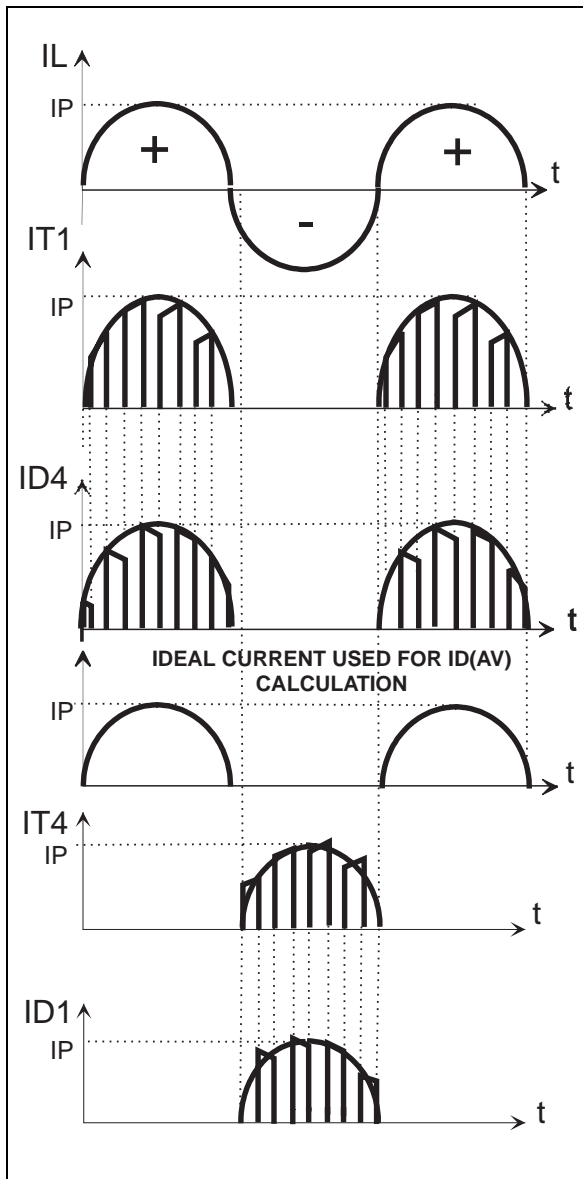

When a transistor switches ON with a high di/dt , (typically $250A/\mu s$) the recovery current of the complementary diode flows in this transistor, inducing turn ON losses in the transistor : PON.

In the following bar graph we compare the losses due to six STTA506D with six STTB506D, in the following conditions :

$P=1kVA$ $V_a=400V$ $F_c=10kHz$ $di/dt=200A/\mu s$

Notations :

POFF : turn OFF losses in the six diodes

POND : turn ON losses in the six diodes

PCOND : conduction losses of the six diodes (calculated with (1))

PON : turn ON losses in the six transistors due to the recovery current of the diodes

F_c : switching frequency

STTA506D :

TURBOSWITCH™ 600V diode Family A
 V_{Fmax} (5A, 125°C)=1.5V
 t_{rr} max (1A, 50A/ μs , 30V)=50ns

STTB506D :

TURBOSWITCH™ 600V diode Family B
 V_{Fmax} (5A, 125°C)=1.3V
 t_{rr} max (1A, 50A/ μs , 30V)=95ns

Fig. 3 : Comparison of losses between 6 STTA506D and 6 STTB506D

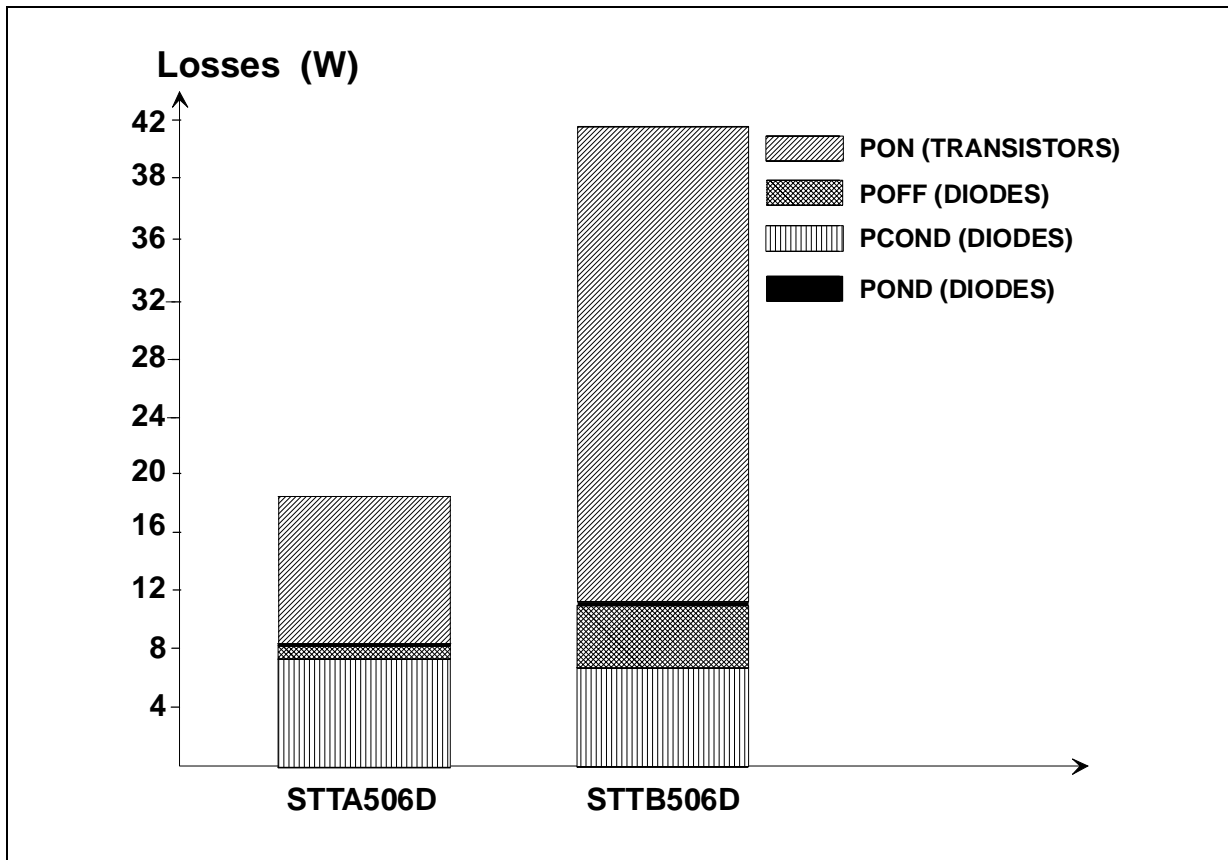

This bar graph shows that it is important to use the faster diode to reduce the total losses in the diodes and in the transistors.

CONCLUSIONS

The switching losses are negligible in comparison to conduction losses.

Average current in each diode is low (Ex.: < 1.1A for 1kVA). A very fast diode has to be used to reduce Turn ON losses in the transistor for switching frequency higher than 1kHz. The TURBOSWITCH™ family A 600V and 1200V is suited to Asynchronous Motor control working respectively on Single-phase (220V) and 3 - phase - (380V) mains.

Information furnished is believed to be accurate and reliable. However, SGS-THOMSON Microelectronics assumes no responsibility for the consequences of use of such information nor for any infringement of patents or other rights of third parties which may result from its use. No license is granted by implication or otherwise under any patent or patent rights of SGS-THOMSON Microelectronics. Specifications mentioned in this publication are subject to change without notice. This publication supersedes and replaces all information previously supplied. SGS-THOMSON Microelectronics products are not authorized for use as critical components in life support devices or systems without express written approval of SGS-THOMSON Microelectronics.

© 1996 SGS-THOMSON Microelectronics - Printed in Italy - All rights reserved.

SGS-THOMSON Microelectronics GROUP OF COMPANIES

Australia - Brazil - Canada - China - France - Germany - Hong Kong - Italy - Japan - Korea - Malaysia - Malta - Morocco - The Netherlands - Singapore - Spain - Sweden - Switzerland - Taiwan - Thailand - United Kingdom - U.S.A.



LittleDiode supplies new, hard to find or obsolete electronic components and semiconductors all over the world.

With over two million different components listed you are sure to find the part you need.

Feel free to visit us today at our online store:

LittleDiode.com

Looking forward to providing you with the best possible service.