

# AN8587SH

## Cellular Telephone PLL IC Incorporating VCO

### Overview

The AN8587SH is a mobile communication PLL IC (Bi-CMOS) incorporating a transmission VCO (TX IF : 90/110 MHz) .

### Features

- LPF switching for high-speed charge up
- VCO components and a PLL are integrated into an IC.
- Small-outline surface-mount package with 0.5 mm pitch
- Provides for a product with fewer components.

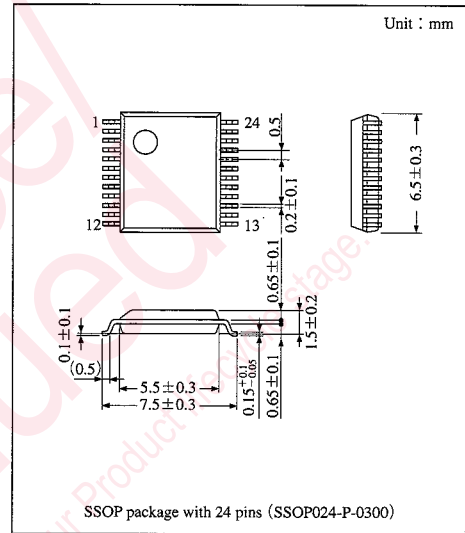

### Block Diagram

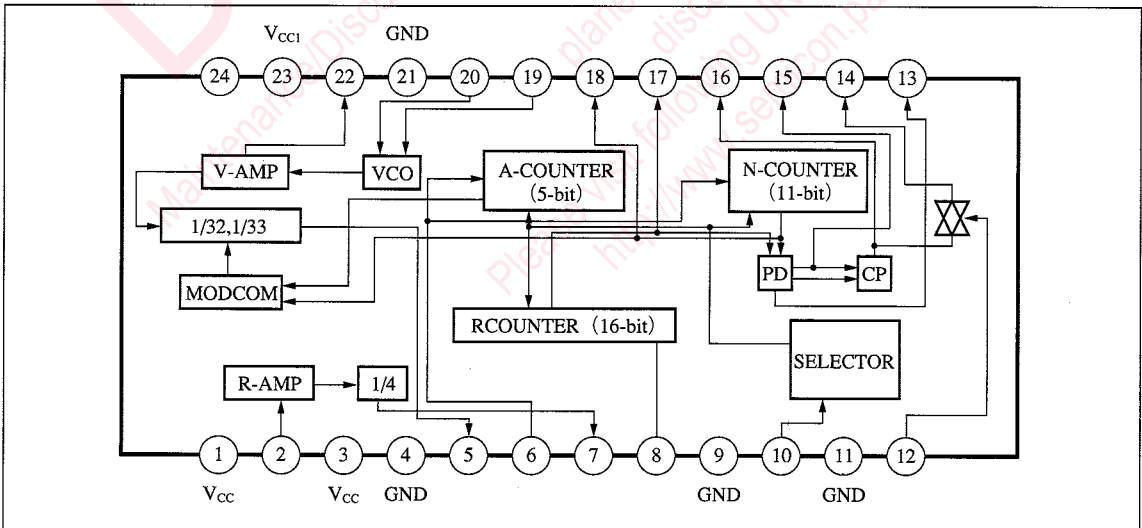

Mobile  
Communi-  
cation

## Pin Descriptions

Pin No.	Description	Pin No.	Description
1	V <sub>CC</sub>	13	Lock detector output
2	Reference input	14	Phase detector output (2)
3	GND	15	External phase detector output (2)
4	V <sub>CC</sub>	16	Phase detector output (1)
5	Var. prescaler (1/32, 1/33) output	17	Ref. counter output
6	Var. counter input	18	Var. counter output
7	Ref. prescaler (1/4) output	19	RES1
8	Ref. counter input	20	RES2
9	GND	21	GND
10	Frequency division switching control (1)	22	RF output
11	Frequency division switching control (2)	23	V <sub>CC1</sub>
12	Phase detection output (2) control SW	24	Regulator output (2.5V)

## Absolute Maximum Ratings (T<sub>a</sub> = 25°C)

Parameter	Symbol	Rating	Unit
Supply voltage	V <sub>CC</sub>	4.5	V
Supply current	I <sub>CC</sub>	28	mA
Power dissipation	P <sub>D</sub>	126	mW
Operating ambient temperature	T <sub>opr</sub>	-20 to +75	°C
Storage temperature	T <sub>stg</sub>	-55 to +125	°C

## Recommended Operating Range

Parameter	Symbol	Range
Operating supply voltage range	V <sub>CC</sub>	3.4V to 4.0V

## Electrical Characteristics (T<sub>a</sub> = 25 ± 2°C)

Parameter	Symbol	Condition	min	typ	max.	Unit
Current consumption	I <sub>CC</sub>	SELECT1 to V <sub>CC</sub> , SELECT2 to GND	—	16.0	19	mA
Reference input level	X <sub>in</sub>	f <sub>in</sub> = 10 to 20MHz f <sub>rout</sub> = f <sub>in</sub> /4	0.5	—	1.0	V <sub>P-P</sub>
Power output (1)	P <sub>out1</sub>	SELECT1 to V <sub>CC</sub> , SELECT2 to GND (P <sub>out</sub> : f <sub>out</sub> = 110.0MHz)	-15	-11.0	—	dBm
Output leak current (1)	I <sub>LCP1</sub>	V <sub>CC1</sub> = 0V V <sub>CP1</sub> = 3.7V, 0V	-1.0	0	1.0	μA
Output leak current (2)	I <sub>LCP2</sub>	V <sub>CC1</sub> = V <sub>CC</sub> SWCONT grounded, V <sub>CP2</sub> = 3.7V, 0V	-1.0	0	1.0	μA
Output voltage (High)	V <sub>HCP</sub>	V <sub>CC1</sub> = 0V I <sub>CP</sub> = -1mA	2.9	3.35	3.8	V
Output voltage (Low)	V <sub>LCP</sub>	V <sub>CC1</sub> = 0V I <sub>CP</sub> = 1mA	-0.10	0.17	0.80	V

Note) Unless otherwise specified, V<sub>CC</sub> = 3.7V

Reference input : When SELECT1 is connected to V<sub>CC</sub> and SELECT2 to GND,  
f<sub>in</sub> = 12.8MHz, and X<sub>in</sub> = 0.7V<sub>P-P</sub>.

**Electrical Characteristics (Design Values for Reference) (Ta=25±2°C)**

The following are design values for reference only (not guaranteed).

Parameter	Symbol	Condition	Typical value	Unit
Power output (2)	Pout2	SELECT1 to GND, SELECT2 to GND (Pout : fout=90.0MHz)	-11.0	dBm
Power output (3)	Pout3	SELECT1 to GND, SELECT2 to Vcc (Pout : fout=90.0MHz)	-11.0	dBm

Note) Unless otherwise specified, Vcc=3.7V

Reference input : When SELECT1 is connected to GND and SELECT2 to GND, fin = 12.80MHz, and Xin=0.7Vp-p.  
When SELECT1 is connected to GND and SELECT2 to Vcc, fin = 15.36MHz, and Xin=0.7Vp-p.

**Usage Note**

**Surge Breakdown Level**

The following are design values for reference only (not guaranteed).

Condition : C=200pF, and R=0Ω

Pin No.	Positive breakdown level (V)
23	200 to 230

**Counter Frequency Dividing Ratio**

Status of SELECT1	L	L	H	H
Status of SELECT2	L	H	L	H
Ref Counter	256	256	256	×
A Counter	0	16	0	×
N Counter	225	187	275	×

◎ VCO's oscillation frequency, fout, is calculated as follows :  
 $f_{out} = [(32 \times N) + A] \times [(f_{in}/4) \div R]$

where R, A, and N are frequency dividing ratios of REF, A, and N counters respectively, and fin is the OSC frequency.  
 If fin is 12.8MHz, then [(fin/4) ÷ R] is 12.5kHz.

◎ Examples of frequency dividing are :  
 fout=90MHz, SELECT1 low, SELECT2 low, and fin=12.80MHz  
 fout=90MHz, SELECT1low, SELECT2 high, and fin=15.36MHz  
 fout=110MHz, SELECT1 high, SELECT2 low, and fin=12.80MHz

Note) The above are design values for reference only (not guaranteed).





## Request for your special attention and precautions in using the technical information and semiconductors described in this book

- (1) If any of the products or technical information described in this book is to be exported or provided to non-residents, the laws and regulations of the exporting country, especially, those with regard to security export control, must be observed.
- (2) The technical information described in this book is intended only to show the main characteristics and application circuit examples of the products. No license is granted in and to any intellectual property right or other right owned by Panasonic Corporation or any other company. Therefore, no responsibility is assumed by our company as to the infringement upon any such right owned by any other company which may arise as a result of the use of technical information described in this book.
- (3) The products described in this book are intended to be used for standard applications or general electronic equipment (such as office equipment, communications equipment, measuring instruments and household appliances).  
Consult our sales staff in advance for information on the following applications:
  - Special applications (such as for airplanes, aerospace, automobiles, traffic control equipment, combustion equipment, life support systems and safety devices) in which exceptional quality and reliability are required, or if the failure or malfunction of the products may directly jeopardize life or harm the human body.
  - Any applications other than the standard applications intended.
- (4) The products and product specifications described in this book are subject to change without notice for modification and/or improvement. At the final stage of your design, purchasing, or use of the products, therefore, ask for the most up-to-date Product Standards in advance to make sure that the latest specifications satisfy your requirements.
- (5) When designing your equipment, comply with the range of absolute maximum rating and the guaranteed operating conditions (operating power supply voltage and operating environment etc.). Especially, please be careful not to exceed the range of absolute maximum rating on the transient state, such as power-on, power-off and mode-switching. Otherwise, we will not be liable for any defect which may arise later in your equipment.
  - Even when the products are used within the guaranteed values, take into the consideration of incidence of break down and failure mode, possible to occur to semiconductor products. Measures on the systems such as redundant design, arresting the spread of fire or preventing glitch are recommended in order to prevent physical injury, fire, social damages, for example, by using the products.
- (6) Comply with the instructions for use in order to prevent breakdown and characteristics change due to external factors (ESD, EOS, thermal stress and mechanical stress) at the time of handling, mounting or at customer's process. When using products for which damp-proof packing is required, satisfy the conditions, such as shelf life and the elapsed time since first opening the packages.
- (7) This book may be not reprinted or reproduced whether wholly or partially, without the prior written permission of our company.



LittleDiode supplies new, hard to find or obsolete electronic components and semiconductors all over the world.

With over two million different components listed you are sure to find the part you need.

Feel free to visit us today at our online store:

[LittleDiode.com](http://LittleDiode.com)

Looking forward to providing you with the best possible service.