

TEA7092 - TELEPHONE SET INTEGRATED CIRCUIT

<b>CONTENTS</b>		<b>Pages</b>
<b>I.</b>	<b>TEA7092 GENERAL INFORMATION</b> .....	3
I.1.	SETTING THE TEA7092 APPLICATION .....	3
I.2.	PINOUT .....	4
I.3.	BLOCK DIAGRAM .....	5
I.4.	INPUT/OUTPUT CONFIGURATIONS .....	6
<b>II.</b>	<b>SPEECH FEATURE</b> .....	14
II.1.	DC CHARACTERISTICS .....	14
II.1.1.	TEA7092 DC Voltage .....	14
II.1.2.	Telephone Set DC Voltage .....	14
II.1.3.	Start Up Characteristics .....	15
II.1.4.	Further Information ( $V_{CC}/V_{REF}/I_{REF}/V_{MC}/V_{RMC}/V_{LS}/V_{REFL}$ ) .....	17
II.2.	IMPEDANCE .....	18
II.3.	TRANSMIT CHANNEL .....	19
II.3.1.	General Information - Maximum Gain Adjustment .....	19
II.3.2.	Softclipping Threshold (Maximum Line Level) .....	20
II.3.3.	Line Loss Compensation A.G.C. Adjustment .....	21
II.3.4.	A.G.C. Inhibition .....	21
II.3.5.	Transmit Squelch / Antiacoustic Feedback Stage .....	22
II.4.	SIDETONE .....	23
II.4.1.	General Information .....	23
II.4.2.	One Sidetone Network Principle .....	24
II.4.3.	Line Tracking Sidetone Network Principle .....	24
II.4.4.	Sidetone Programming for PABX Application .....	25
II.5.	RECEIVE CHANNEL .....	26
II.5.1.	General Information - Maximum Gain Adjustment .....	26
II.5.2.	Maximum Output Level .....	27
II.5.3.	Line Loss Compensation / A.G.C. Adjustment .....	30
II.5.4.	A.G.C. Inhibition .....	30
II.5.5.	+6dB Mode .....	30
II.6.	HANDSFREE INTERFACE .....	30
<b>III.</b>	<b>CALL PROGRESS MONITOR AND GROUP LISTENING MODES</b> .....	31
III.1.	GENERAL INFORMATION .....	31
III.2.	LOUDSPEAKING PART SUPPLY .....	32
III.3.	SOFTCLIPPING STAGE .....	33
III.4.	ANTIACOUSTIC FEEDBACK FEATURES .....	33
III.5.	MAXIMUM OUTPUT POWER .....	35
III.6.	EXTERNAL POWER SUPPLY FACILITY .....	36
III.7.	RING MELODY CONTROL MODE .....	37
III.8.	BEEP ERROR GENERATOR .....	38

<b>CONTENTS (continued)</b>		<b>Pages</b>
<b>IV.</b>	<b>MICROCONTROLLER INTERFACE</b> .....	39
IV.1.	MICROCONTROLLER POWER SUPPLY .....	39
IV.2.	RESET AND PON SIGNALS .....	39
IV.3.	SERIAL BUS INTERFACE .....	41
IV.3.1.	Different Codes .....	41
IV.3.2.	Software Example .....	45
IV.3.3.	Serial Bus Codes Actions on Switches .....	46
IV.4.	RING INDICATOR / LINE CURRENT VARIATION INDICATOR .....	47
IV.5.	OSCILLATOR .....	47
IV.6.	MICROCONTROLLER SIGNAL CONTROL IN THE DIFFERENT MODES. ....	47
<b>V.</b>	<b>DIALER FEATURES</b> .....	48
V.1.	DTMF DIALER .....	48
V.2.	SINE WAVE GENERATOR .....	49
V.3.	PULSE DIALER INTERFACE .....	49
<b>VI.</b>	<b>RINGER FEATURES</b> .....	50
VI.1.	RINGER POWER SUPPLY .....	50
VI.2.	START UP THRESHOLD LEVEL .....	50
VI.3.	RING FREQUENCY GENERATOR .....	51
VI.4.	OUTPUT POWER OPTIMIZATION .....	51
VI.4.1.	Switch Mode Power Supply Concept .....	51
VI.4.2.	Switch Mode Power Supply Losses .....	52
VI.4.3.	Output Power Adjustment .....	53
VI.5.	MICROCONTROLLER MANAGEMENT .....	54
VI.6.	RING SOFTWARE .....	55
<b>VII.</b>	<b>APPLICATION DIAGRAM</b> .....	56

### I - TEA7092 GENERAL INFORMATION

#### I.1 - Setting the TEA7092 Application

TEA7092 is a telephone set integrated circuit designed to meet various country's requirements.

TEA7092 is adapted to each country through external component value modifications.

TEA7092 performs the following features :

- Speech (Line interface & 2 wires / 4 wires)
- Call progress monitor (Exchange tone heard in the loudspeaker & On-Hook dialing)
- Group listening (Handset & loudspeaker used simultaneously)
- Handfree interface
- Ring on Loudspeaker
- DTMF dialing
- DC mask in Pulse dialing mode (Tip & Ring voltage reduced during make period)
- Microcontroller interface
- Line current variation detector for transfer
- Waiting melody generator
- Beep error generator

All these features can be programmed by the associated microcontroller through the serial bus interface.

**Make a copy of the last page of this document and keep it as a reference, when you read this application note, if you want to refer to the external component names.**

When setting the application, it is preferable to respect the following flow chart :

#### **Speech Part and DTMF Dialing**

- Start your application with the default component values given at the last page of this document (typical application).
- Adjust the **DC and START-UP characteristics**.
- Adjust the **Impedance** (return loss).

- Adjust the **Transmit parameters** (softclipping level, gain, frequency response curve).
- Adjust the **Sidetone network(s)\***.
- Adjust the **Receive parameters** (gain, frequency response curve)\*.
- Adjust the **DTMF output level**.

\* Each of these two adjustments is influenced by the other one, for more information, see Sections II.4 & II.5.

#### **Call Progress Monitor and Group Listening**

- Adjust the **Loudspeaking amplifier** (gain, frequency response curve) without handset connection in order to avoid influence of the handset microphone.
- Adjust the **Antiacoustic feedback efficiency**.

#### **Ringer Part**

- Choose the **Ring frequency melody**.
- Adjust the **Ring start up level**.
- Optimize the **loudspeaker output power**.

#### **Further Features**

- Tip & Ring DC value in the make period in pulse dialing mode,
  - Line current variation detector for transfer,
  - Waiting melody generator,
  - Beep error generator,
  - Microcontroller interface,
- are essentially software programming.

**Note :** Throughout the application note,  $I_L$  is the current which power supplies the complete application (current is equivalent to the one delivered by an exchange to power a telephone set). For the entire application note, unless otherwise specified, the component values are those given at the last page of this document (typical application).

## TEA7092 - TELEPHONE SET INTEGRATED CIRCUIT

### I - TEA7092 GENERAL INFORMATION (continued)

#### I.2 - Pinout

Pin N°	Name	Function
1	V <sub>LS</sub>	Loudspeaker Power Supply
2	V <sub>MC</sub>	Unregulated Microcontroller Power Supply
3	V <sub>L</sub>	Transmit Output Stage
4	V <sub>REFL</sub>	Loudspeaker Reference Voltage (V <sub>LS</sub> /2)
5	LSIN	Loudspeaker Amplifier Input
6	LSSOF	Loudspeaker Softclipping Time Constant
7	DTMF1	DTMF Filter 1
8	V <sub>RMC</sub>	Stabilized Microcontroller Power Supply
9	OSC	Oscillator Input
10	RI/VI	Ring Indicator/Line Current Variation Indicator Output (*)
11	RESET	Microcontroller Reset Output (*)
12	PON	Line Current Indicator Output (*)
13	CLK	Serial Bus Clock Input (*)
14	DATA	Serial Bus Data Input (*)
15	SNSL	Short Line Sidetone Network
16	SNLL	Long Line Sidetone Network
17	ASQ	Anti-Acoustic Feedback and Squelch Time Constant
18	ASC	DC Offset Anti-Acoustic Feedback and Squelch Amplifier Suppression
19	RECI	Receive Input and Positive Line Voltage
20	REOUT	Receive Output for Handfree Interface and Loudspeaker Input
21	GTR	Transmit Gain Adjustment
22	HFIN	Handfree Microphone Input Referenced to V <sub>REF</sub>
23	MIC1	Microphone Input 1 Referenced to V <sub>REF</sub>
24	MIC2	Microphone Input 2 Referenced to V <sub>REF</sub>
25	V <sub>REF</sub>	Speech Reference Voltage (V <sub>CC</sub> /2)
26	V <sub>CC</sub>	Speech Power Supply
27	TSOFT	Transmit Softclipping Time Constant
28	SOFTL	Transmit Softclipping Level Adjustment
29	I <sub>REF</sub>	Resistor to Set Reference Current
30	V <sub>S</sub>	Active Inductor and DC Characteristic Adjustment
31	SLPE	DC Mask Slope Adjustment
32	AGND	Analog Ground and Negative Line Voltage
33	I <sub>LL</sub>	Long Line Speech Control Gain Adjustment (GMAX)
34	I <sub>SL</sub>	Short Line Speech Control Gain Adjustment (GMAX - 6dB)
35	EAR+	Positive Earphone Output
36	EAR-	Negative Earphone Output
37	GREC	Receive Gain Adjustment
38	V <sub>ZP</sub>	Switch Mode Power Supply Internal Zener
39	SWP	Switch Mode Power Supply Output
40	RSU	Ring Start Up Level
41	RCO	Ring Power Output Control
42	DTMF2	DTMF Filter 2
43	GND	Power Ground and Negative Line Voltage
44	LSOUT	Loudspeaker Output

\* Logic Interface.

# TEA7092 - TELEPHONE SET INTEGRATED CIRCUIT

## I - TEA7092 GENERAL INFORMATION (continued)

### I.3 - Block Diagram

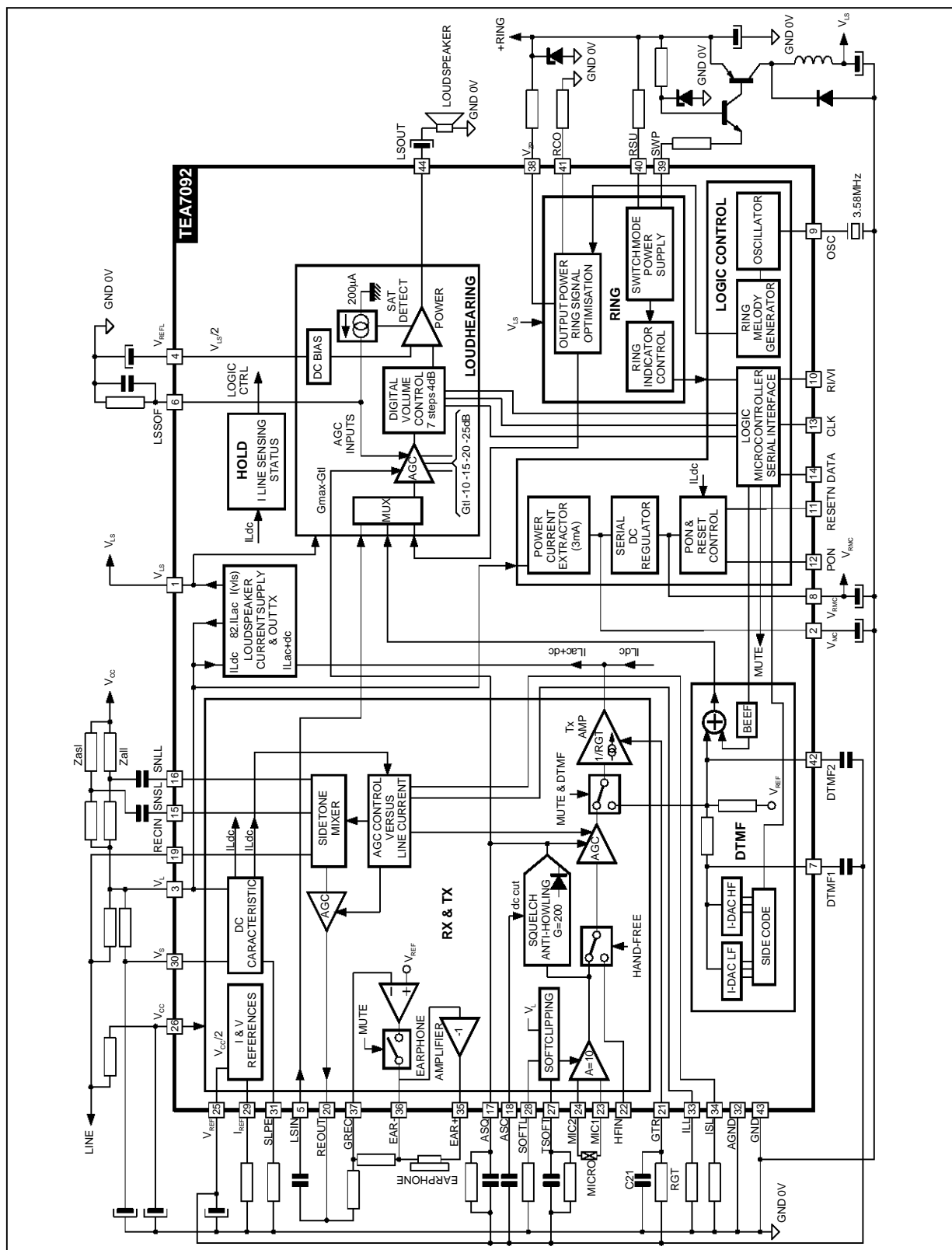

AN84B-01.EPS

# TEA7092 - TELEPHONE SET INTEGRATED CIRCUIT

## I - TEA7092 GENERAL INFORMATION (continued)

### I.4 - Input / Output Configurations

**Figure 1 :**  $V_{REF}$  (Pin 25) : Transmit and Receive Reference Voltage ( $V_{CC}/2$ )  
 $V_{CC}$  (Pin 26) : Transmit and Receive Power Supply  
 $I_{REF}$  (Pin 29) : Internal Reference Current

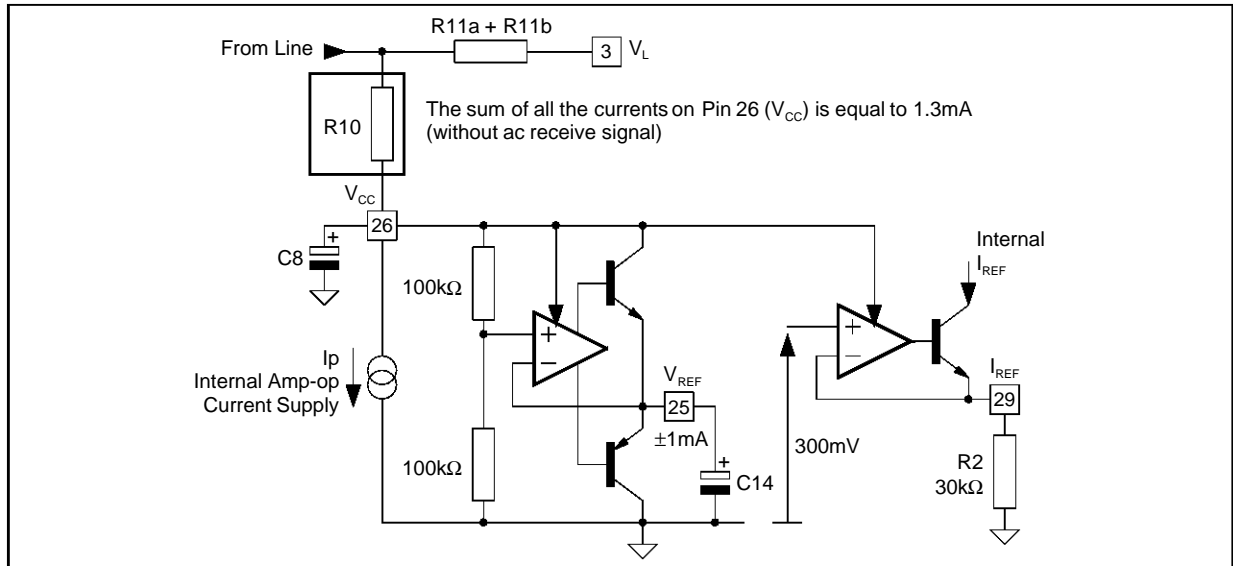

AN848-02.EPS

**Figure 2 :** SLPE (Pin 31) : DC Mask Slope  
 $V_s$  (Pin 30) : Shunt Regulator

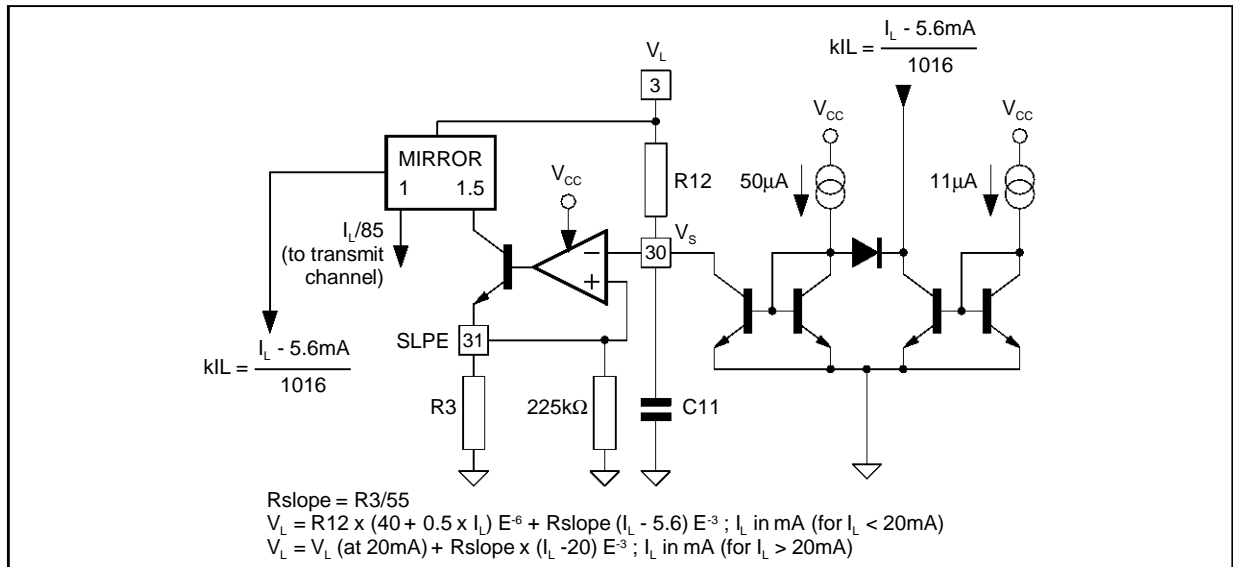

AN848-03.EPS

I - TEA7092 GENERAL INFORMATION (continued)

I.4 - Input / Output Configurations (continued)

**Figure 3 :**  $V_{LS}$  (Pin 1) : Loudspeaker Part Power Supply  
 $V_{MC}$  (Pin 2) : Unregulated Microcontroller Power Supply  
 $V_{RMC}$  (Pin 8) : Stabilized Microcontroller Supply

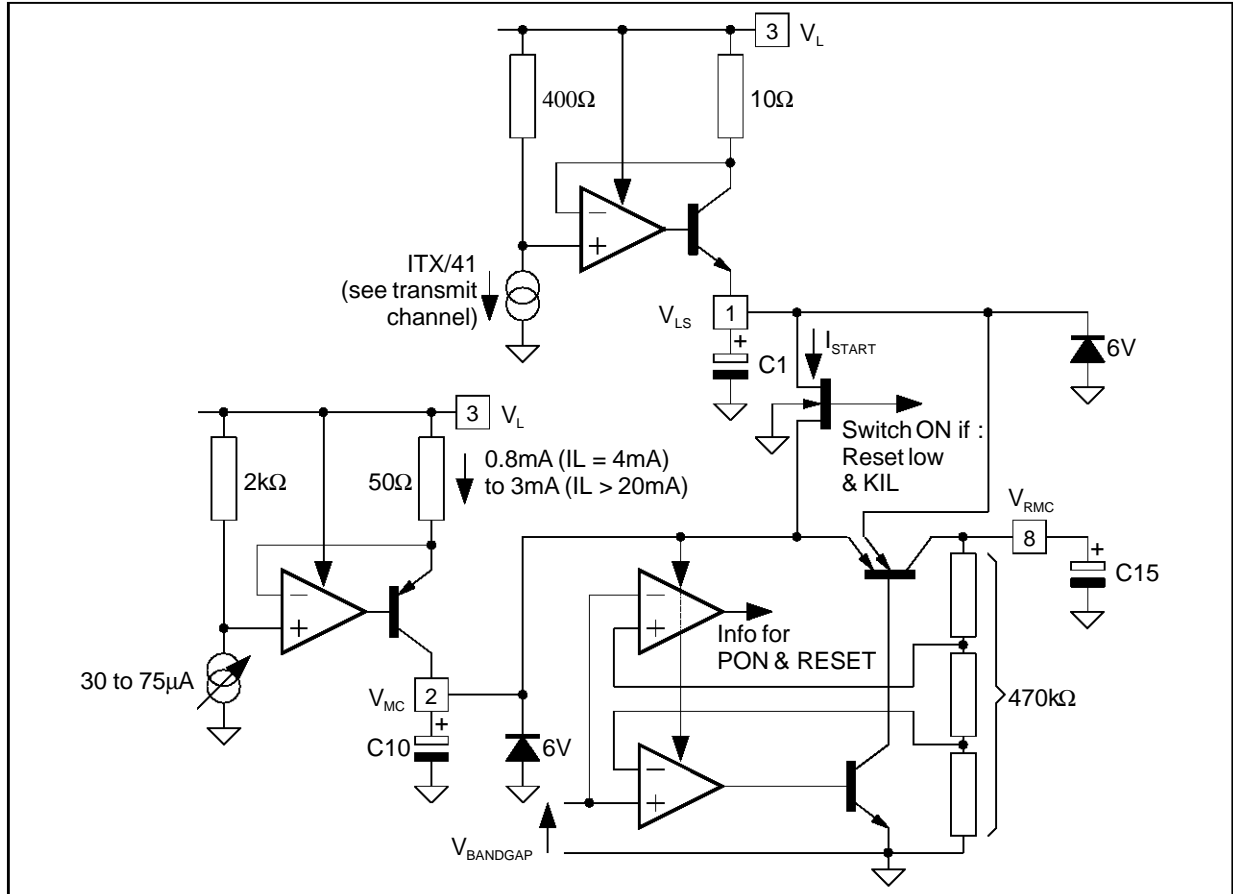

AN848-04.EPS

**Figure 4 :**  $I_{LL}$  (Pin 33) : Line Current Regulation Start-up Value  
 $I_{SL}$  (Pin 34) : Line Current Regulation Stop Value

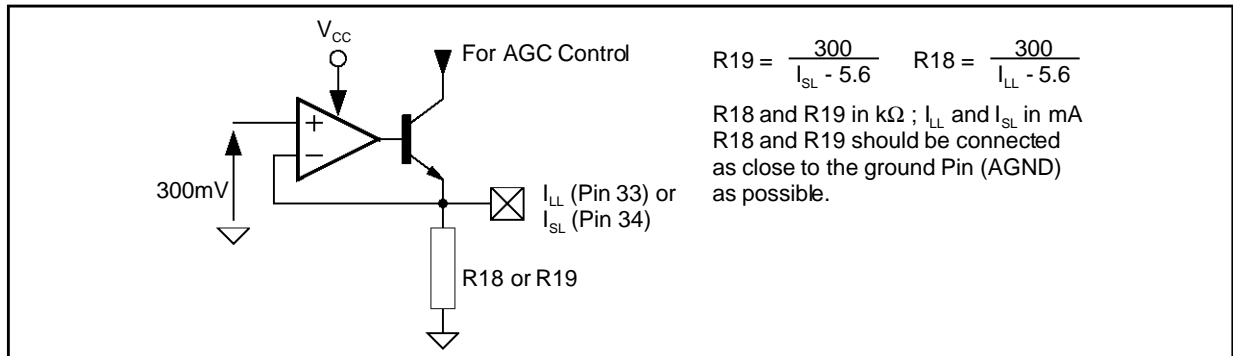

AN848-05.EPS

# TEA7092 - TELEPHONE SET INTEGRATED CIRCUIT

## I - TEA7092 GENERAL INFORMATION (continued)

### I.4 - Input / Output Configurations (continued)

- Figure 5 :** TSOFT (Pin 27) : Transmit Softclipping Time Constant  
 SOFTL (Pin 28) : Maximum AC Signal (Softclipping Threshold)  
 MIC1/MIC2 (Pin 23/24) : Microphone Inputs  
 HFIN (Pin 22) : Handsfree Microphone Input  
 DTMF1 (Pin 7) : DTMF Input and Filter  
 DTMF2 (Pin 42) : DTMF Filter  
 GTR (Pin 21) : Transmit Gain Adjustment

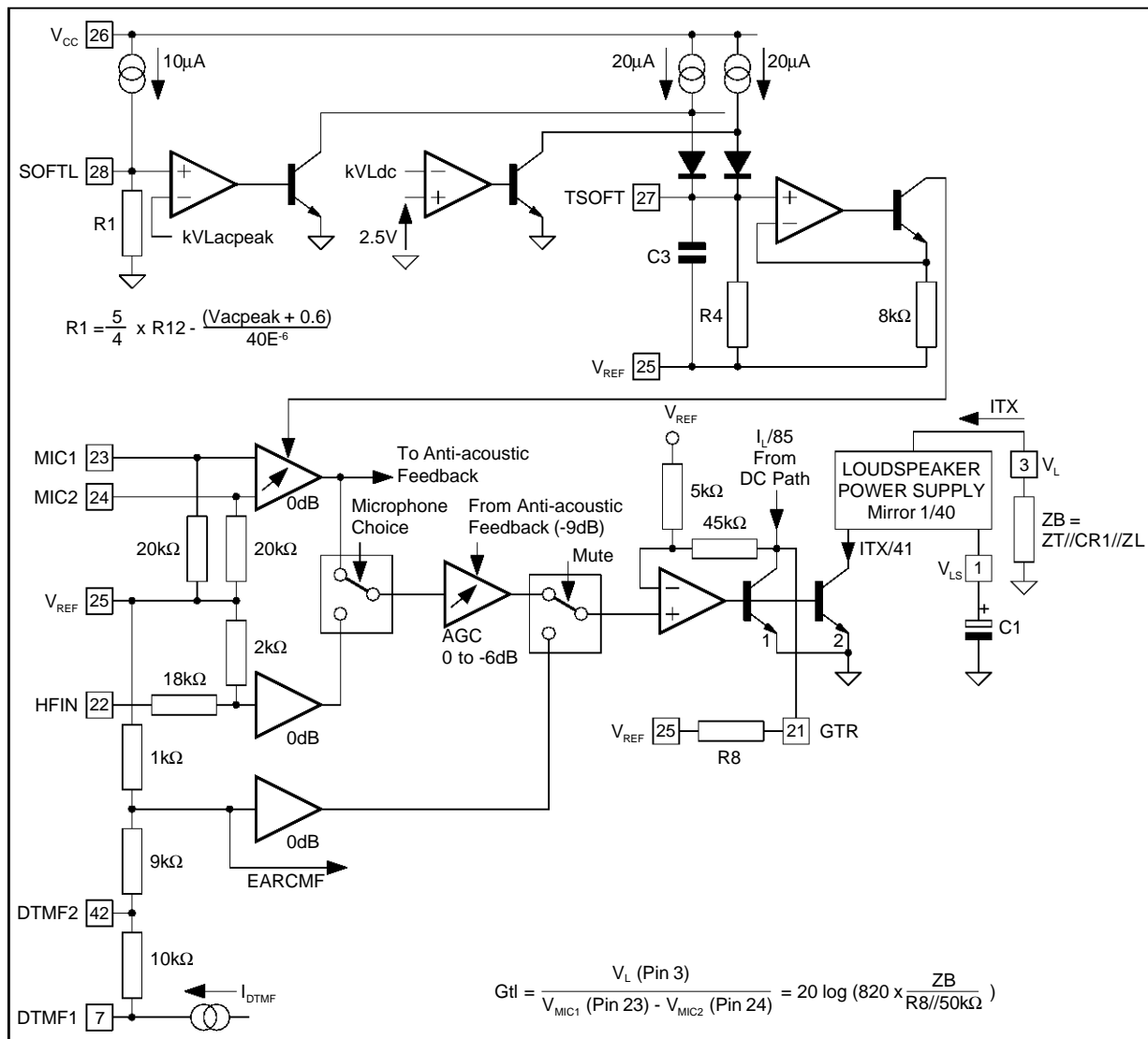

I - TEA7092 GENERAL INFORMATION (continued)

I.4 - Input / Output Configurations (continued)

**Figure 6 :** SNSL (Pin 15) : Short Line Length Sidetone Network Input  
 SNLL (Pin 16) : Long Line Length Sidetone Network Input  
 RECIN (Pin 19) : Receive Input  
 REOUT (Pin 20) : Receive Output for Handsfree Device  
 GREC (Pin 37) : Receive Gain Adjustment  
 EAR+ (Pin 35) : Positive Earphone Output  
 EAR- (Pin 36) : Negative Earphone Output

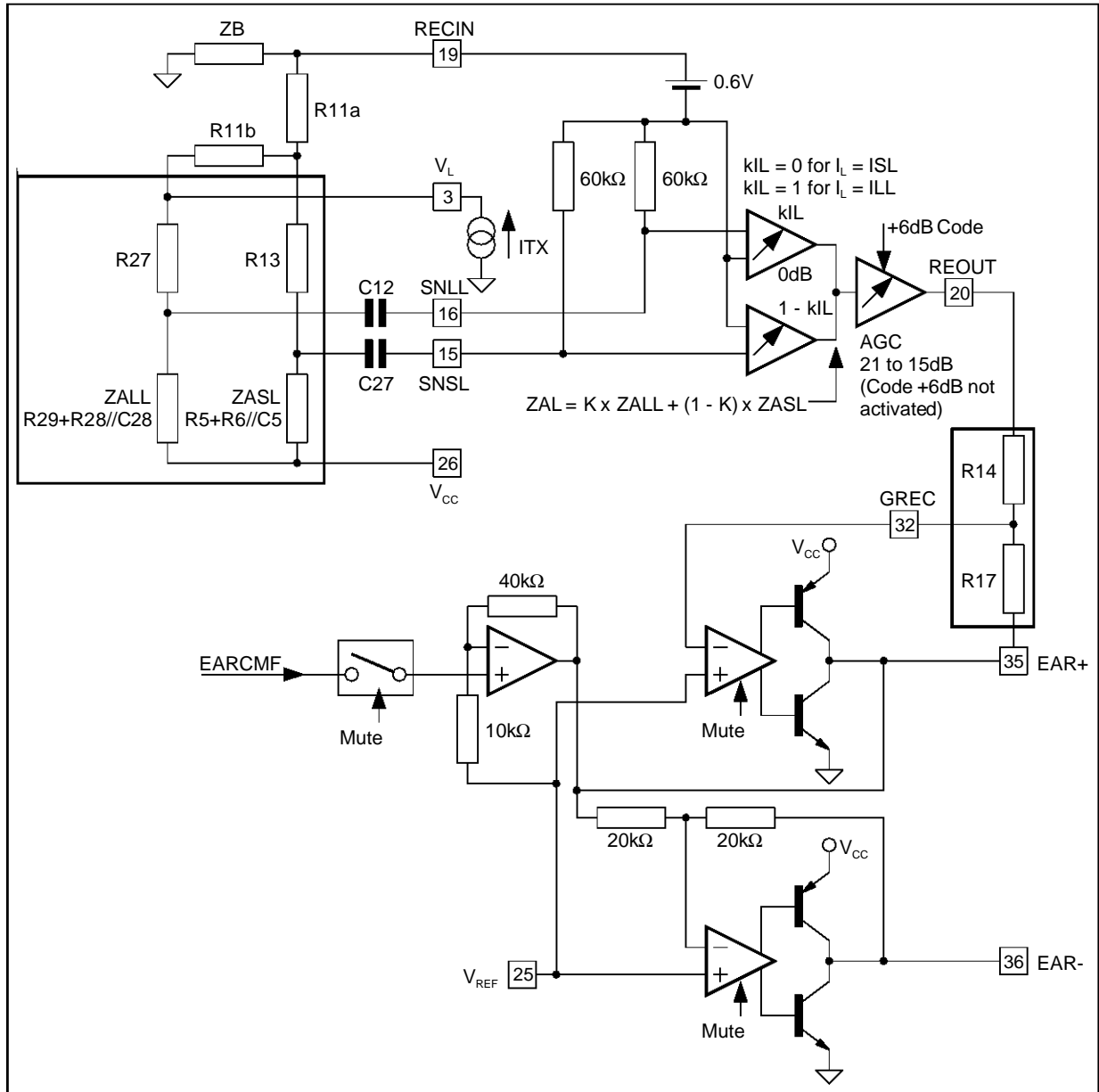

AN848-07.EPS

# TEA7092 - TELEPHONE SET INTEGRATED CIRCUIT

## I - TEA7092 GENERAL INFORMATION (continued)

### I.4 - Input / Output Configurations (continued)

**Figure 7 :** LSIN (Pin 5) : Loudspeaker Signal Input  
 LSOUT (Pin 44) : Loudspeaker Output  
 V<sub>REFL</sub> (Pin 4) : LoudspeakerPart Reference Voltage

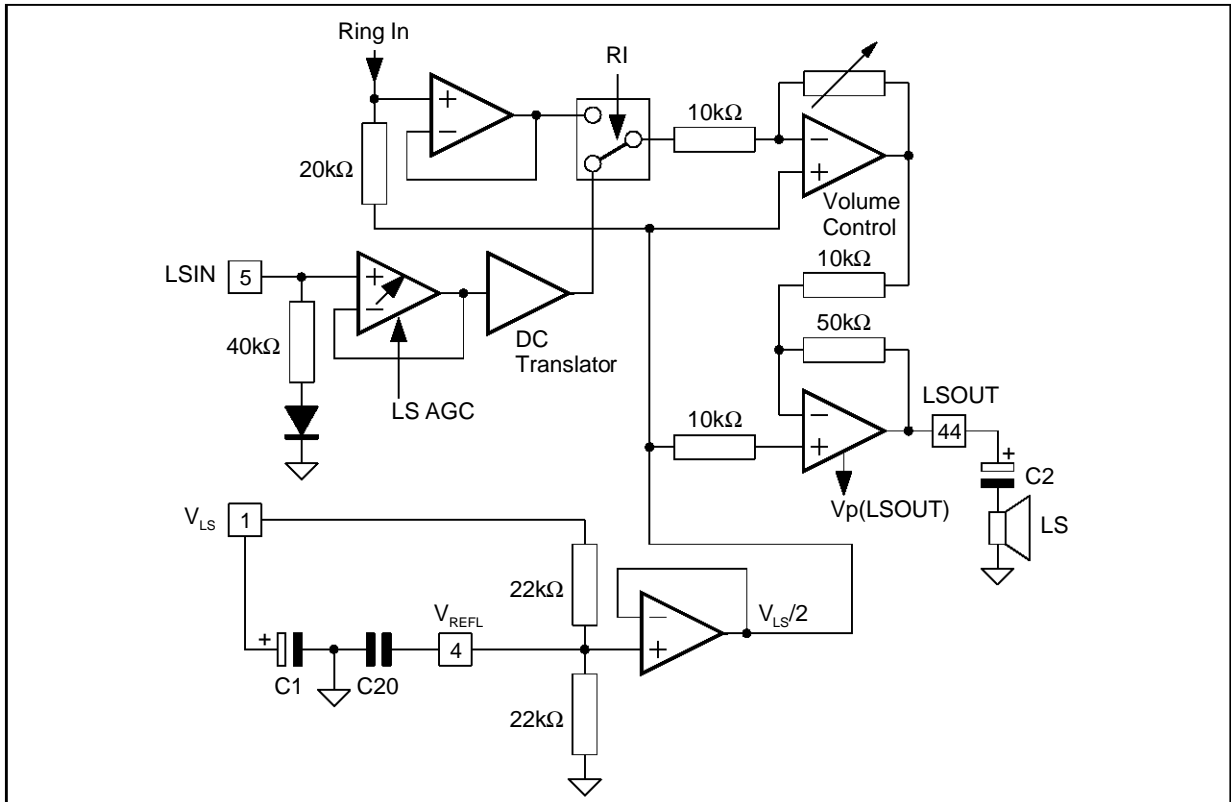

AN848-08/EPS



# TEA7092 - TELEPHONE SET INTEGRATED CIRCUIT

## I - TEA7092 GENERAL INFORMATION (continued)

### I.4 - Input / Output Configurations (continued)

**Figure 9 :**  $V_{ZP}$  (Pin 38) : Switch Mode Power Supply Internal Zener  
 SWP (Pin 39) : Switch Mode Power Supply Output  
 RSU (Pin 40) : Ring Start-up Level  
 RCO (Pin 41) : Ring Power Output Control

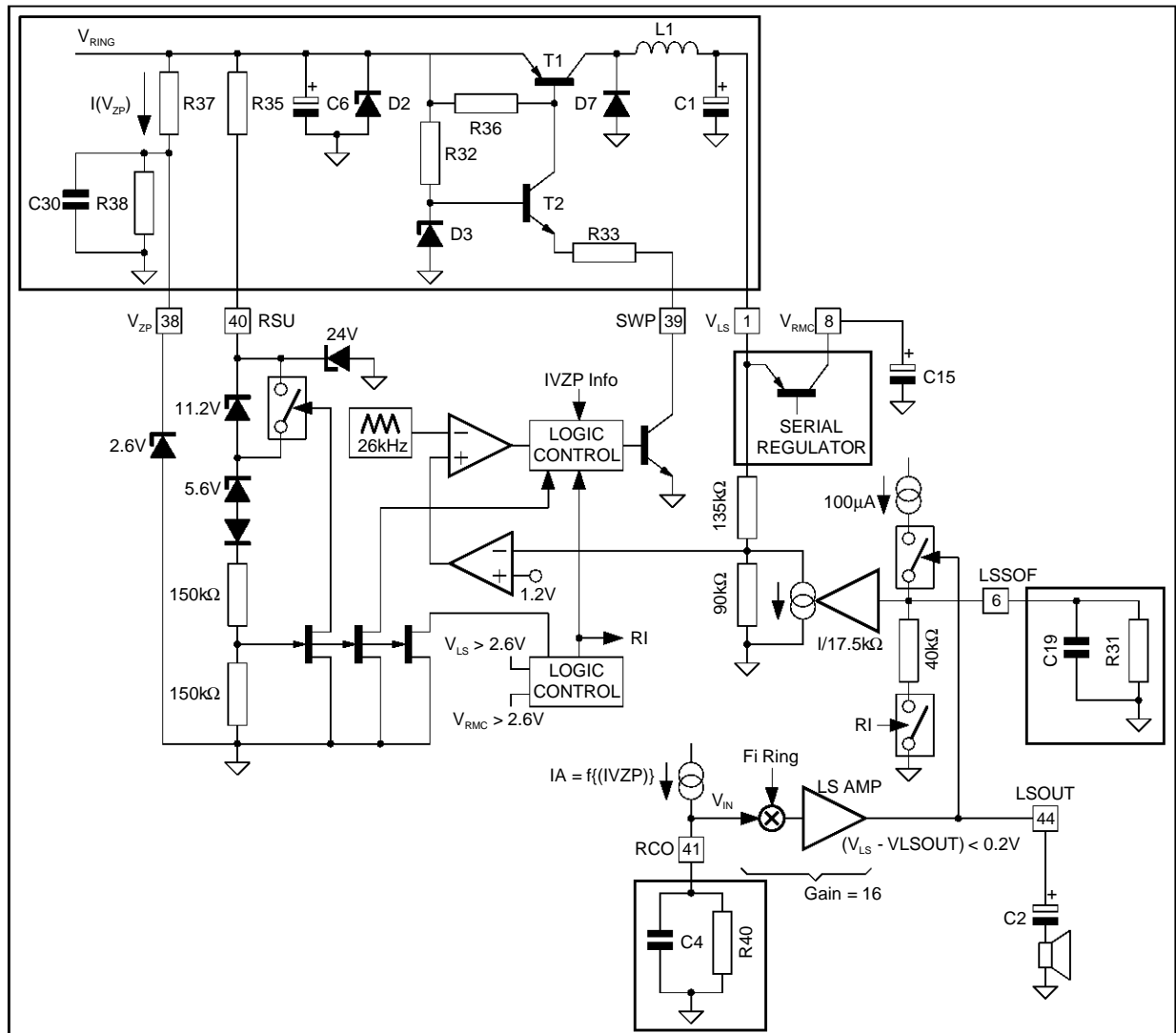

AN848-10LEPS

I - TEA7092 GENERAL INFORMATION (continued)

I.4 - Input / Output Configurations (continued)

Figure 10 : RI/VI (Pin 10) : Ring Indicator/Line Current Variation

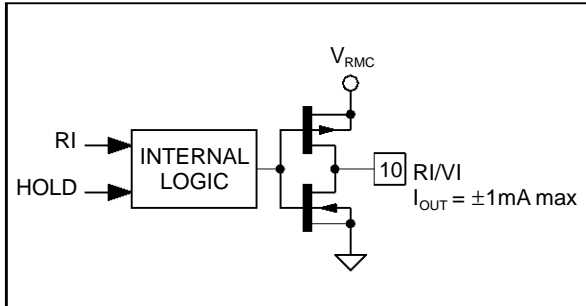

AN848-11.EPS

Figure 11 : CLK (Pin 13) : Clock Data Input  
DATA (Pin 14) : Data Input

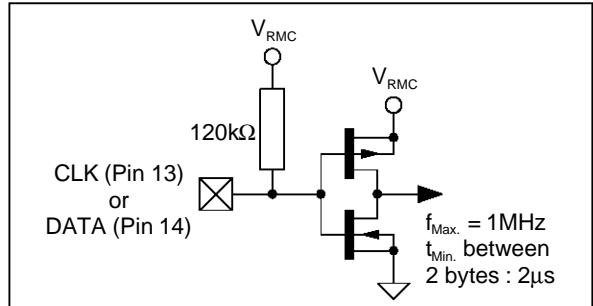

AN848-12.EPS

Figure 12 : OSC (Pin 9) : Oscillator Input

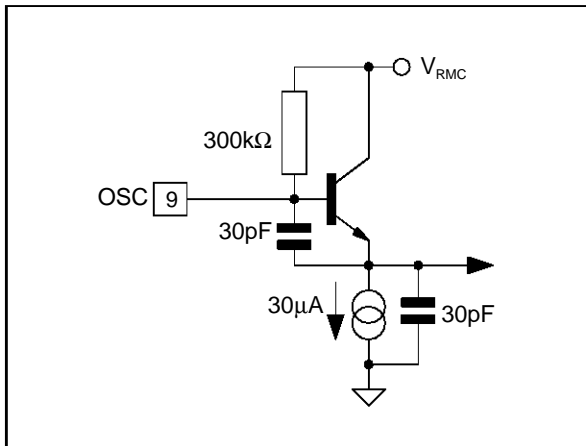

AN848-13.EPS

Figure 13 : RESET (Pin 11) :  $\mu$ controller Reset  
PON (Pin 12) : Power On Output

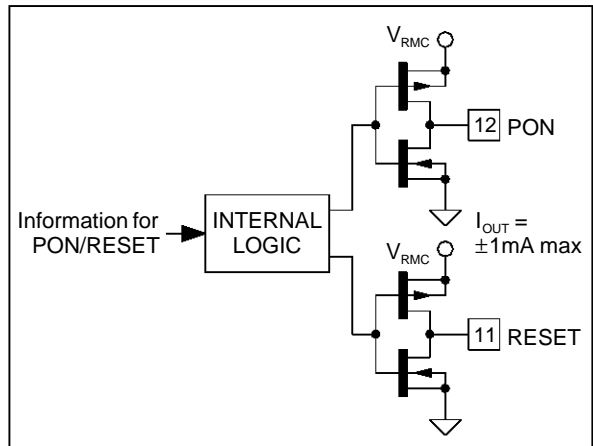

AN848-14.EPS

## TEA7092 - TELEPHONE SET INTEGRATED CIRCUIT

### II - SPEECH FEATURES

#### II.1 - DC Characteristics

##### II.1.1 - TEA7092 DC Voltage

The voltage at Pin  $V_L$  (Pin 3) of the TEA7092 is fixed by 2 external components :

- R3 connected between Pin SLPE (Pin 31) and the ground which fixes the DC slope.
- R12 connected between Pin  $V_L$  (Pin 3) and Pin  $V_S$  (Pin 30) which fixes the DC voltage at  $I_L = 20\text{mA}$  and a part of the DC slope for  $I_L < 20\text{mA}$ .

The voltage at Pin  $V_L$  (Pin 3) is equal to :

For  $I_L < 20\text{mA}$  :

$$V_L = R12 \cdot (40 + 0.5 \cdot I_L) \cdot 10^{-6} + \frac{R3 \cdot (I_L - 5.6)}{55} \cdot 10^{-3}$$

with  $I_L$  in mA.

For  $I_L > 20\text{mA}$  :

$$V_L = V_L(20\text{mA}) + \frac{R3 \cdot (I_L - 20)}{55} \cdot 10^{-3}$$

with  $I_L$  in mA,  $V_L(20\text{mA})$  is the Pin  $V_L$  (Pin 3) DC value for  $I_L = 20\text{mA}$ .

##### II.1.2 - Telephone Set DC Voltage

The telephone set DC voltage at line terminal is equal to (see Figure 14) :

$$V(LA/LB) = V_L + (R11a + R11b) \cdot I_L + V_{SWI} + V_{BRI}$$

with :

- $V_L$  : DC voltage on Pin  $V_L$  (Pin 3) of the TEA7092.
- $V_{SWI}$  : voltage across the pulse dialing switch and its protection.
- $V_{BRI}$  : voltage across the input rectifier bridge.

The Figures 15 to 18 give DC typical value at Pin  $V_L$  (Pin 3) and at line terminal (LA/LB) for different value of R3 and R12.

**Note :** At the maximum line current use, the voltage at Pin RECIN (Pin 19) should be less than  $11V_{DC}$ , the following curves stop at the line current where they reach  $11V_{DC}$  at Pin RECIN (Pin 19), depending of the country's application, use this information to optimize the values of R3 and R12.

Figure 14

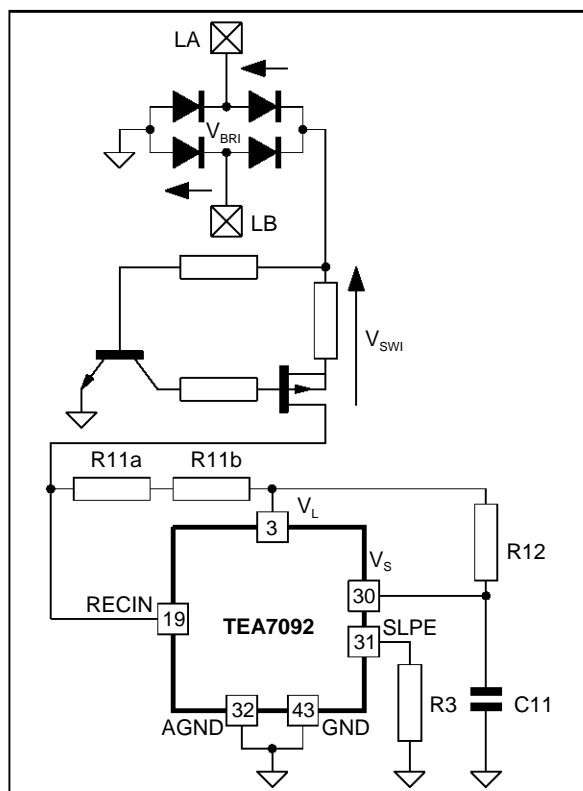

AN688-15.EPS

II - SPEECH FEATURES (continued)

II.1.2 - Telephone Set DC Voltage (continued)

Figure 15 : Telephone Set (DC MASK)

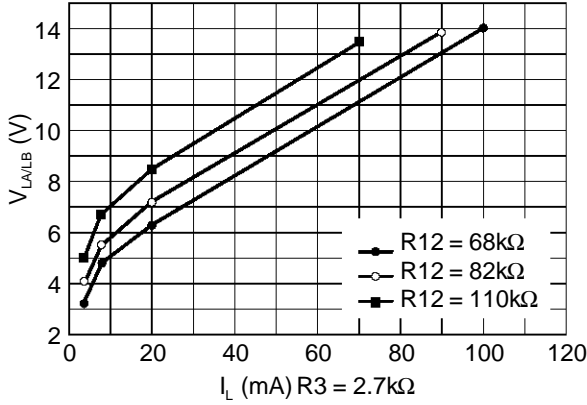

Figure 16 :  $V_{RECIN}$  (Pin 19)

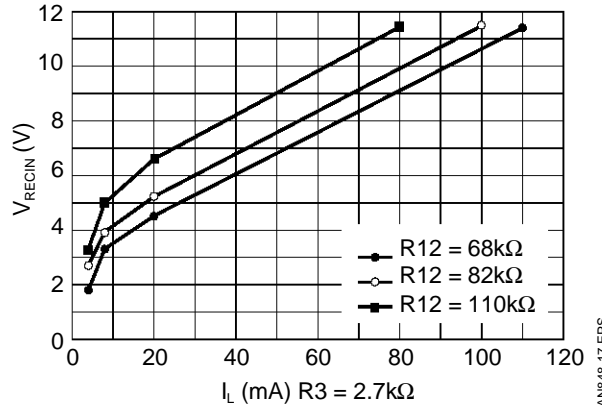

Figure 17 : Telephone Set (DC MASK)

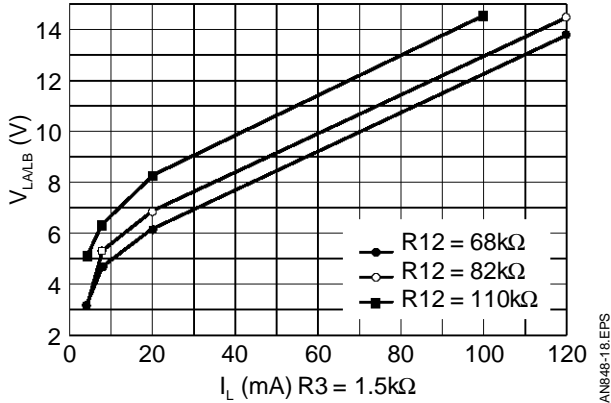
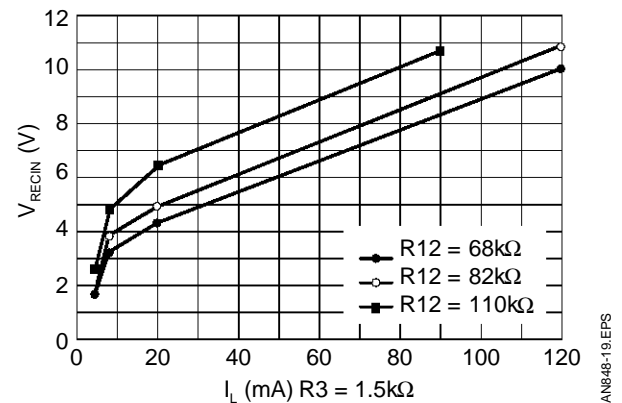

Figure 18 :  $V_{RECIN}$  (Pin 19)



II.1.3 - Start-up Characteristics

When TEA7092 goes from idle state (ON-HOOK) to speech mode (OFF-HOOK) the capacitor C10 connected on Pin  $V_{MC}$  (Pin 2) and the capacitor C15 connected on Pin  $V_{RMC}$  (Pin 8) are charged in priority, with the main part of the line current.

The capacitor C10 is used to supply, through a serial regulator, the microcontroller connected on the regulated 3.5V supply, Pin  $V_{RMC}$  (Pin 8).

In pulse dialing, flash or earth button mode the capacitor C10 is used to supply the microcontroller, depending on the power consumption of the microcontroller and on the country's requirements for these different signal durations, it is necessary to adapt the value of C10.

Typical capacitor values, with a current consumption of 500 $\mu$ A for the microcontroller :

$$C10 = 470\mu\text{F} , C15 = 4.7\mu\text{F}.$$

# TEA7092 - TELEPHONE SET INTEGRATED CIRCUIT

## II - SPEECH FEATURES (continued)

### II.1.3 - Start-up Characteristics (continued)

Figure 19 describes the start-up principle.

Figure 19

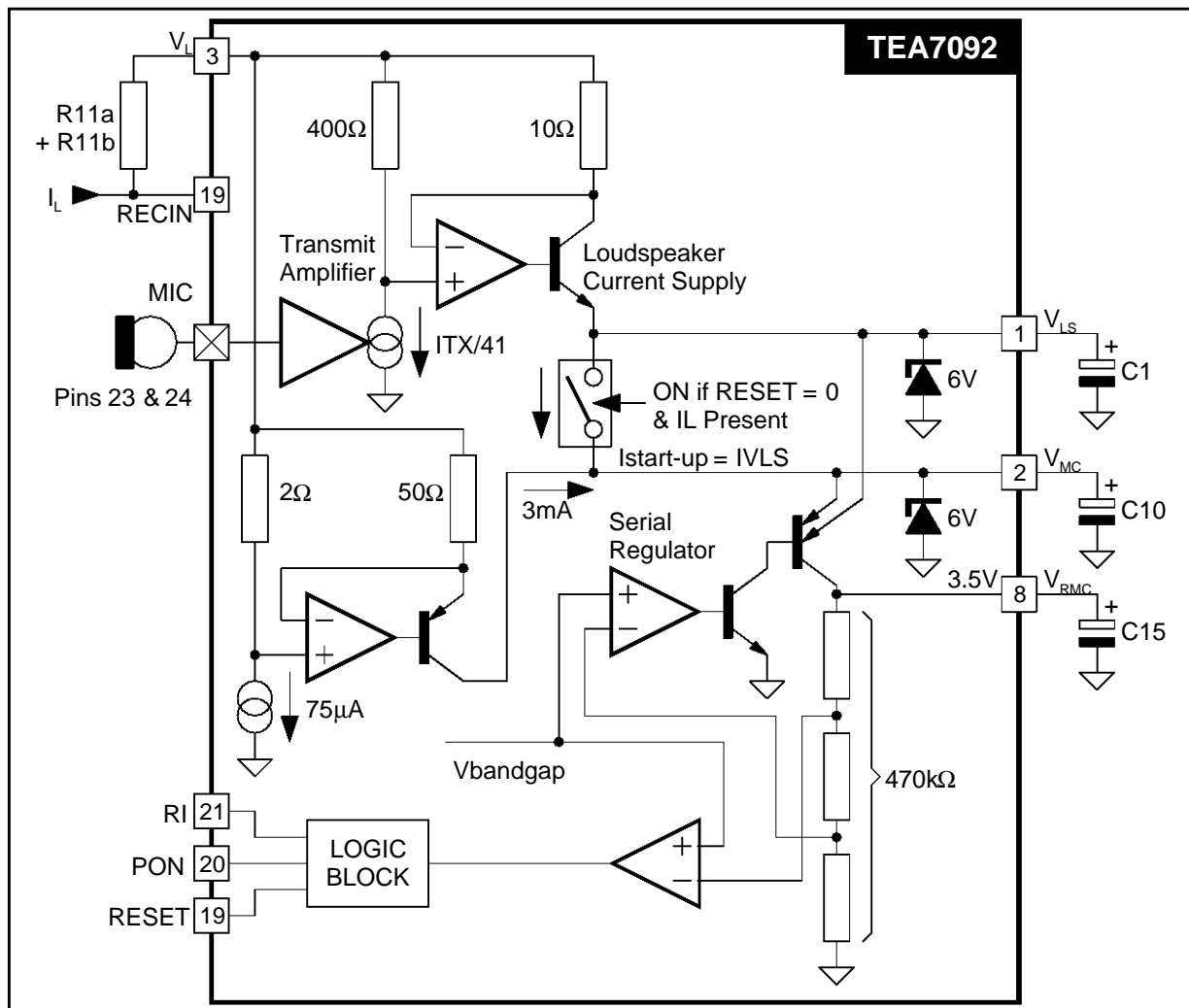

When  $V_{RMC}$  reaches 2.6V, the Reset goes to high level, the start-up current source is inhibited and only connected to Pin  $V_{LS}$  (Pin 1), to power supply the loudspeaker amplifier. The Pin  $V_{RMC}$  (Pin 8) reaches its final value, 3.5V by charging the C10 on Pin  $V_{MC}$  (Pin 2) and C15 on Pin  $V_{RMC}$  (Pin 8) with 3mA current source and finally the voltage on Pin  $V_{MC}$  (Pin 2) increases until its final value which is equal to Pin  $V_L$  (Pin 3) minus 0.4V.

Figure 20 gives the start up characteristic timing. When TEA7092 goes from idle state (ON-HOOK) to ring mode, only the 4.7μF capacitor C15 on Pin  $V_{RMC}$  (Pin 8) is charged, with Iring current source, and a fast start up delay could be achieved in ring mode.

Figure 20

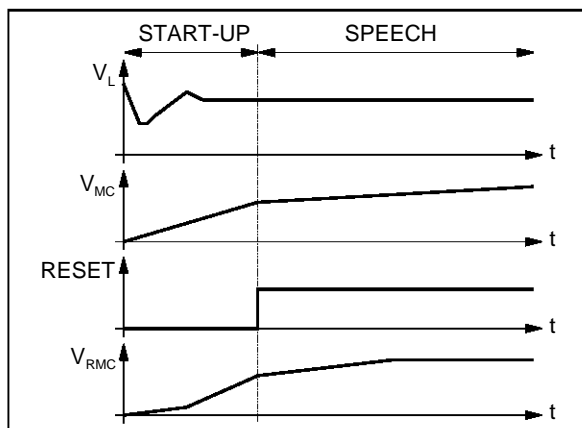

II - SPEECH FEATURES (continued)

II.1.4 - Further Information ( $V_{CC}$  /  $V_{REF}$  /  $I_{REF}$  /  $V_{MC}$  /  $V_{RMC}$  /  $V_{LS}$  /  $V_{REFL}$ )

For more information on these pins see Section I.4 - Input/output Configurations.

**$V_{CC}$  (Pin 26) ,  $V_{REF}$  (Pin 25) ,  $I_{REF}$  (Pin 29)**

The  $V_{CC}$  supplies the transmit path, handset and handfree microphone amplifiers, the receive path, earphone amplifier and the transmit squelch/antia-coustic feedback stage.

The current consumption on this pin,  $I_P$ , is 1.3mA at a 20mA line current (see Figure 21).

From the  $V_{CC}$  supply, the  $V_{REF}$  stage is built.  $V_{REF}$  is used as an AC ground for all the stages powered from  $V_{CC}$ .

The output current compliance of  $V_{REF}$  is :  $\pm 1$ mA.  
The reference voltage at  $V_{REF}$  is :  $V_{CC}/2$ .

$I_{REF}$  Pin is used as an internal current reference. The R2 value is fixed and should not be modified. It is recommended to connect a  $\pm 1\%$  resistor value on this pin.

The voltage at  $I_{REF}$  pin has a 300mV constant value.

The DC value at  $V_{MC}$  is :

$$V_{MC} = V_L - 0.4V$$

and is internally limited at 6V max.

$V_{RMC}$  is powered from the highest DC value between Pin  $V_{LS}$  (Pin 1) and Pin  $V_{MC}$  (Pin 2) in OFF-HOOK state or from Pin  $V_{LS}$  (Pin 1) in ring mode.

$V_{RMC}$  is a 3.5V stabilized power supply.

$V_{RMC}$  supplies the oscillator, the logic part (Micro-controller interface, error beep, and ring frequency generators) and the logic part of the D.A.C. used for the waiting melody and the DTMF generators.

The current consumption on this pin is 250 $\mu$ A when the oscillator is ON and 50 $\mu$ A when the oscillator is OFF code (0111010) is sent.

**Note :** To reduce the C10 value connected at Pin  $V_{MC}$  (Pin 2), it is recommended to inhibit the oscillator during the pulse dialing and flash signalizations.

In ring mode only the 4.7 $\mu$ F capacitor connected on Pin  $V_{RMC}$  (Pin 8) is charged to achieve a short delay to generate the ring signal on the loudspeaker.

Figure 21

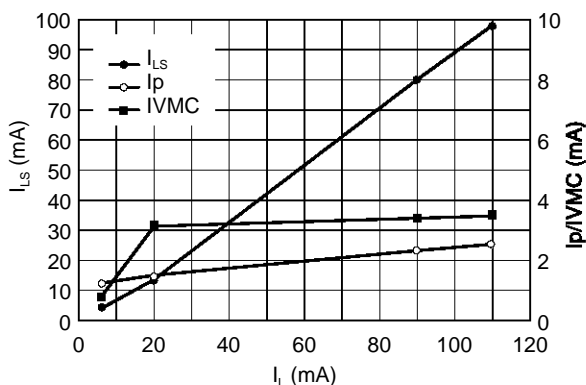

**$V_{MC}$  (Pin 2) ,  $V_{RMC}$  (Pin 8)**

These 2 pins supply the microcontroller. These 2 pins are connected through a serial regulator.

On  $V_{MC}$  a 470 $\mu$ F capacitor is connected, this capacitor is charged only when TEA7092 is powered from Pin  $V_L$  (Pin 3) (OFF-HOOK state) and is used to power supply the microcontroller during pulse dialing, flash and earth button, when the line loop is open.

As described in Section II.1.3, this capacitor is quickly charged during the "Start up" condition.

**$V_{LS}$  (Pin 1) ,  $V_{REFL}$  (Pin 4)**

The  $V_{LS}$  supplies the loudspeaker amplifier part. The current source,  $I_{LS}$ , between the Pin  $V_L$  (Pin 3) and the Pin  $V_{LS}$  (Pin 1) gives the main part of the line current to supply the loudspeaker amplifier (see Figure 21) :

$$I_{LS} = 0.74 \times I_L - 1.8mA ; \text{ for } I_L < 15mA$$

$$I_{LS} = 0.92 \times I_L - 4.5mA ; \text{ for } I_L > 15mA$$

The internal current consumption on  $V_{LS}$  is 1mA, so the current  $I_{LS1}$  available for the loudspeaker and other peripherals is :

$$I_{LS1} = I_{LS} - 1mA$$

The DC value at  $V_{LS}$  depends of the DC value at Pin  $V_L$  (Pin 3) and is equal to :

$$V_{LS} \text{ (Pin 1)} = V_L \text{ (Pin 3)} - (0.95 + 10 \times I_{LS}) \text{ Volts}$$

From the  $V_{LS}$  supply, the  $V_{REFL}$  stage is built. The  $V_{REFL}$  is buffered in order to be used as an AC ground for all the stages powered from  $V_{LS}$ .

The reference voltage at  $V_{REFL}$  is :  $V_{LS}/2$ .

# TEA7092 - TELEPHONE SET INTEGRATED CIRCUIT

## II - SPEECH FEATURES (continued)

### II.2 - Impedance

Figure 22 : TEA7092 Application Impedance

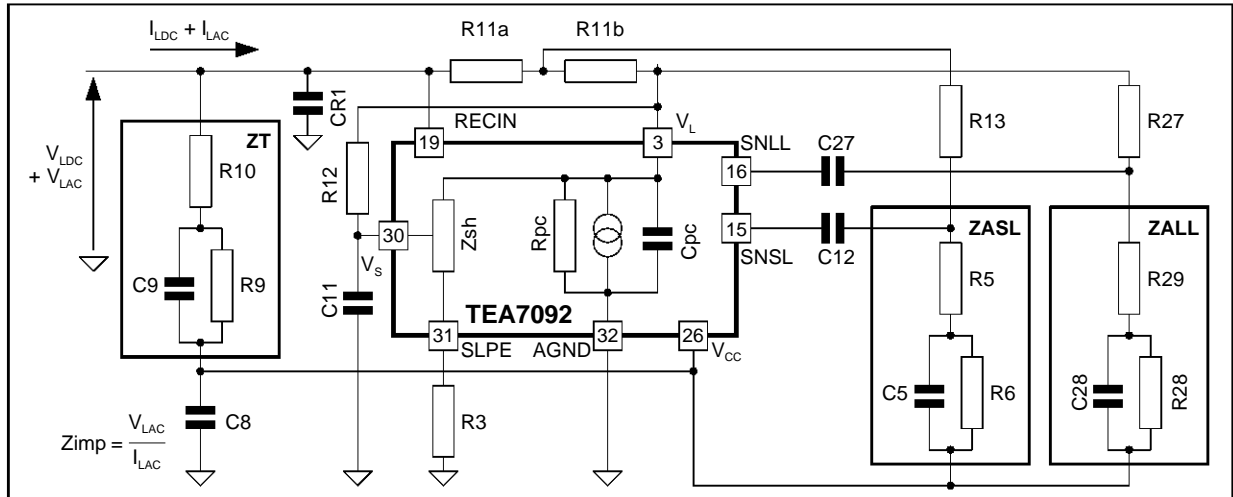

**ZT** Allows the user to adjust the set impedance by changing the value of R10, R9 and C9 ; In this way the impedance can be adjusted as a real one (only R10) or as a complex one (R10, R9, C9).

**ZALL** Sidetone networks which are in parallel with ZALS ZT, if the ratio : R13/R11a >> 1 and R27/(R11a+R11b) >> 1, ZALL and ZASL are negligible for the impedance calculation.

**ZIC** Is the internal impedance of TEA7092. It includes the impedance of the transmit path which is equivalent to a current source in parallel with Cpc (3nF), the impedance of all the other stages which are equivalent to Rpc (15kΩ) and the impedance of the shunt regulator stage (AC/DC decoupling stage) made on Pin 30 (Vs).

TEA7092 application impedance is :

$$Z_{imp} = ZT // ZIC // (ZALL + R11a + R11b) // (ZASL + R11a) // CR1$$

As it will be describe in Section II.4, the sidetone networks are equal to :

$$Z_{ALL} = \frac{R27}{R11a + R11b} \cdot (ZT // CR1 // ZLL)$$

$$Z_{ASL} = \frac{R13}{R11a} \cdot (ZT // CR1 // ZSL)$$

Where ZLL is the long line impedance, and ZSL is the short line impedance.

If R27/(R11a+R11b) and R13/R11a are higher than 100 (R27 and R13 = 3.3kΩ) :

$$Z_{ALL} \text{ and } Z_{ASL} \gg ZT \text{ and } : Z_{imp} = ZT // ZIC // CR1$$

Figure 24 and the Table 1 give the TEA7092 application characteristics at I<sub>L</sub> = 40mA.

Figure 23 : Zsh Impedance

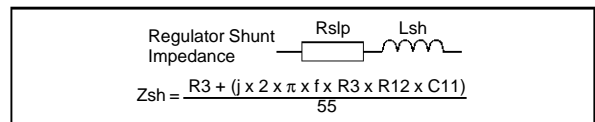
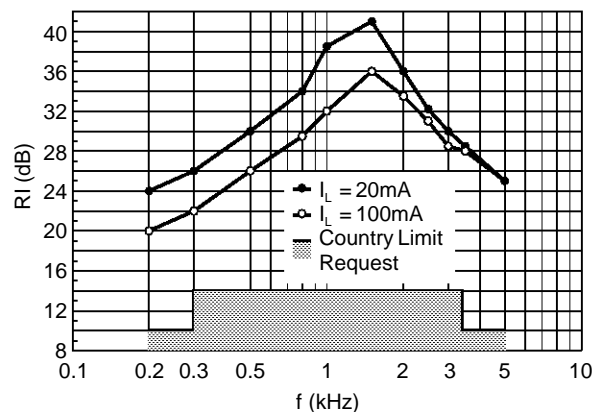

Table 1 (R<sub>I</sub> = 20 · log [Z<sub>imp</sub> + 600] / [Z<sub>imp</sub> - 600])

Frequency (Hz)	Real Part ( )	Imaginary Part ( )	Module ( )	Phase (deg)	Return Loss [R <sub>I</sub> ] (dB)
200	550	80	556	8	21.7
300	573	67	577	7	24.2
800	604	22	605	2	34.6
1 000	606	12	607	1	38.8
1 500	608	-5	608	0	42.1
2 500	606	-28	607	-3	32.6
3 500	603	-43	605	-4	28.8
5 000	597	-67	601	-6	25
7 000	589	-94	596	-9	22
9 000	579	-119	591	-12	19.8
12 000	560	-154	581	-15	17.3

Figure 24 : Return Loss



II - SPEECH FEATURES (continued)

II.3 - Transmit Channel

II.3.1 - General Information

(Maximum Gain Adjustment)

The transmit path amplifies several signals :

- The handset microphone.
- The handfree microphone.
- The DTMF sinewave.
- The waiting melody sinewave.

At one time, only one of these signals is amplified, the choice is made through the serial bus interconnected with the microcontroller.

Figure 25 gives the transmit channel block diagram.

The first switch selects the microphone used.

The signal coming from the handset microphone, Pins MIC1 & MIC2 (Pins 23 & 24) is limited by the softclipping stage, more details are given in Section II.3.2 "Softclipping threshold" on this stage. Its gain depends on the gain control stage programming, more details are given in Section II.3.3 "Line loss compensation A.G.C. adjustment". Its absolute value is adjusted on the final stage with Pin GTR (Pin 21).

The output signal of the handset microphone pre-amplifier is used for the squelch feature.

Figure 25 : Transmit Channel Block Diagram

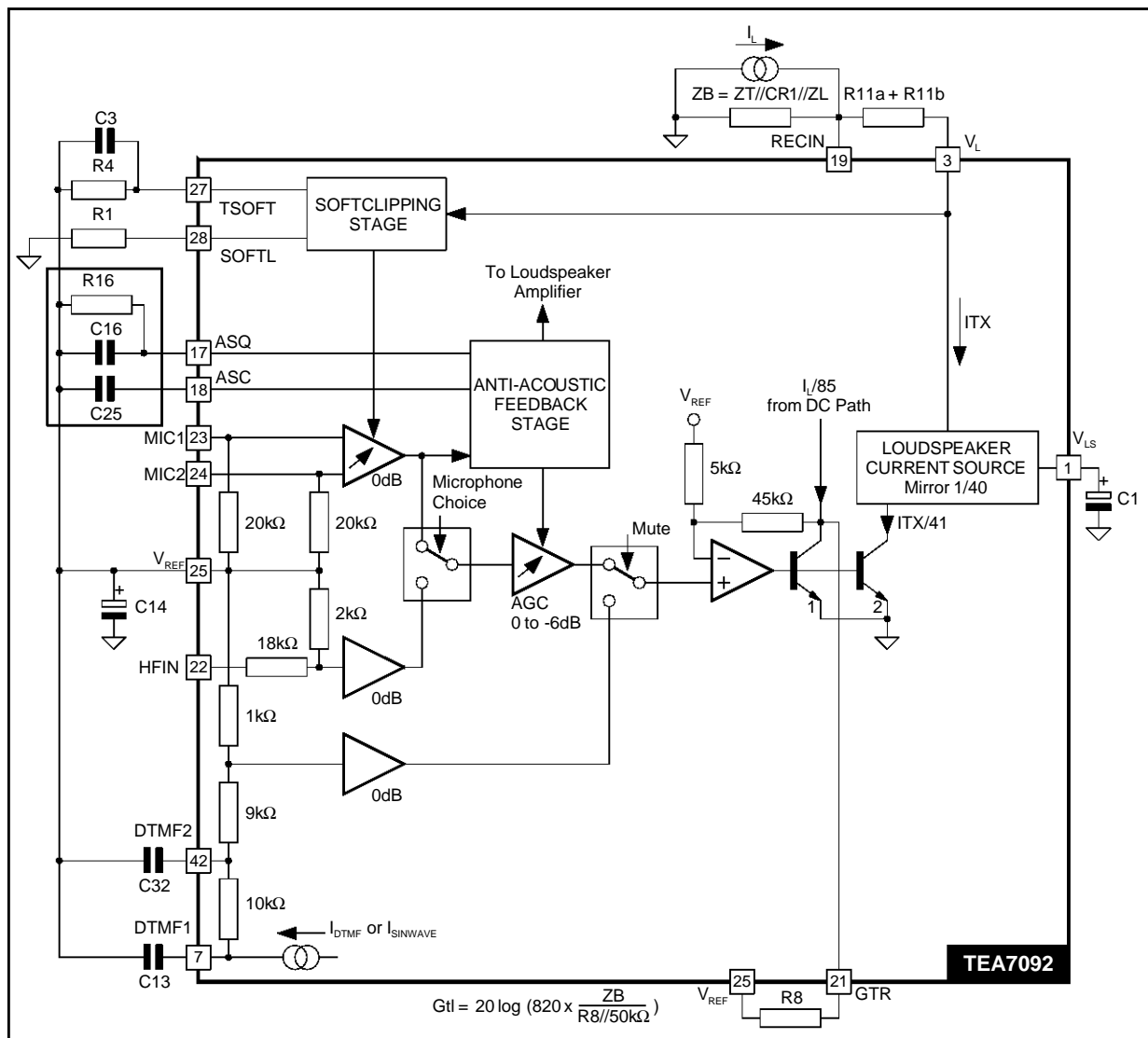

II - SPEECH FEATURES (continued)

II.3 - Transmit Channel (continued)

Figure 26 : Softclipping Stage

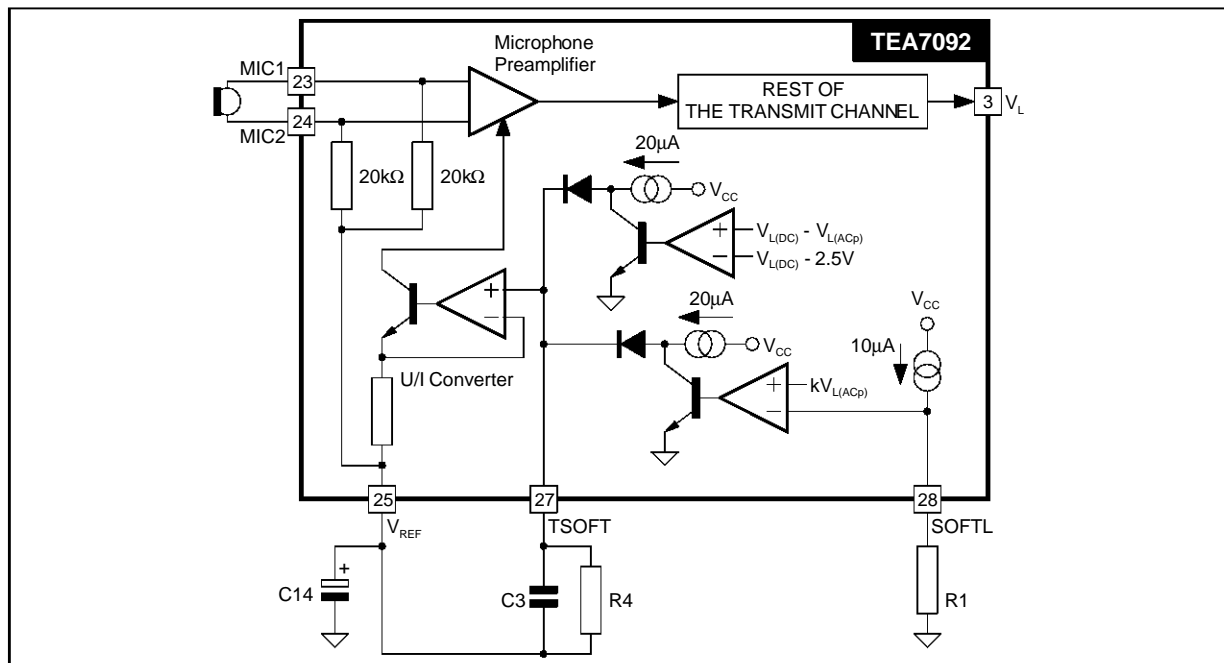

AN848-27.EPS

The second switch selects the microphone signal, the mute mode, the DTMF mode or the sinewave mode (waiting frequency).

The maximum transmit gain,  $G_{tl}$  is fixed by R8 connected on Pin GTR (Pin 21) and is equal, on Pin  $V_L$  (Pin 3) to :

$$G_{tl} = 20 \cdot \log \left( 820 \cdot \frac{ZT//CR1//ZL + (R11a + R11b)}{R8//50k\Omega} \right)$$

$Z_{imp}$  is the complete telephone set application and  $ZL$  is the line impedance.  $50k\Omega$  is the value of the integrated resistor connected between the Pin GTR (Pin 21) and the Pin  $V_{REF}$  (Pin 25).

If it is necessary, to have a steady gain over the frequency range 300Hz to 3.4kHz, R8 can be replaced by a complex network :  $R8 + R7//C7$ .

The final amplifier stage is the loudspeaker current source supply, which is modulated by the transmit signal, therefore no significant line current is used for the transmit path, and the current source supply for the loudspeaker part versus the line current is always optimized.

II.3.2- Softclipping Threshold (Maximum Line Level)

The softclipping stage limits the transmit level on line.

This level is limited in two ways :

The transmit negative part of the sinewave is com-

pared to  $2.5V_{DC}$ . This limitation is useful for low line current when the DC level at Pin  $V_L$  (Pin 3) is low. This limitation is useful when two telephone sets are off-hook in parallel on the same line.

On an absolute line level, this level is fixed by R1 connected on Pin SOFTL (Pin 28) and depends on R12 value :

$$V_{acpeak} = (5 \times R12 - 4 \times R1) \times 10^{-5} - 0.6$$

Figure 26 describes the softclipping stage.

Figure 27 gives an example of the  $V_{ACPEAK}$  transmit level versus line current for  $R12 = 82k\Omega$  and  $R1 = 47k\Omega$ .

Figure 27

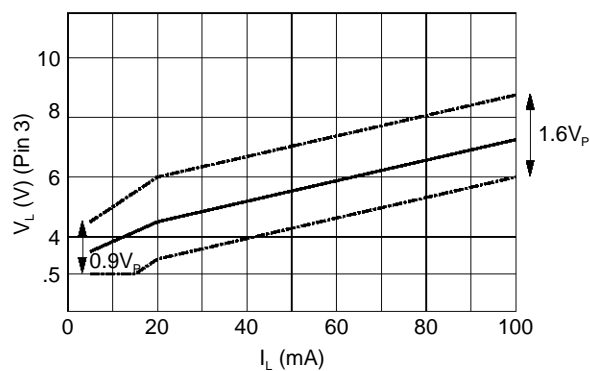

AN848-28.EPS

II - SPEECH FEATURES (continued)

II.3 - Transmit Channel (continued)

Figure 28 gives the transmit line level at Pin  $V_L$  (Pin 3) and the transmit distortion versus the input microphone level (Pin MIC1 (Pin 23) & Pin MIC2 (Pin 24)) for  $R_{12} = 82k\Omega$ ,  $R_1 = 47k\Omega$  &  $R_8 = 1.62k\Omega$ .

Figure 28 : Tx Output Level & Distortion ( $I_L=20mA$ )

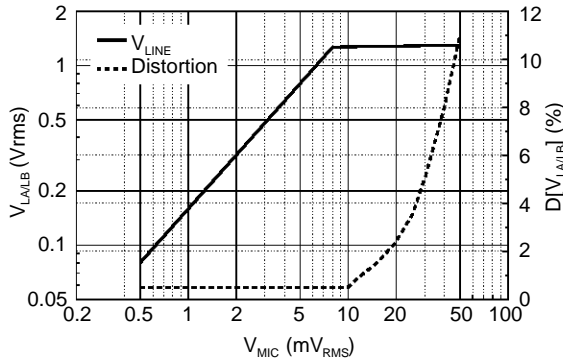
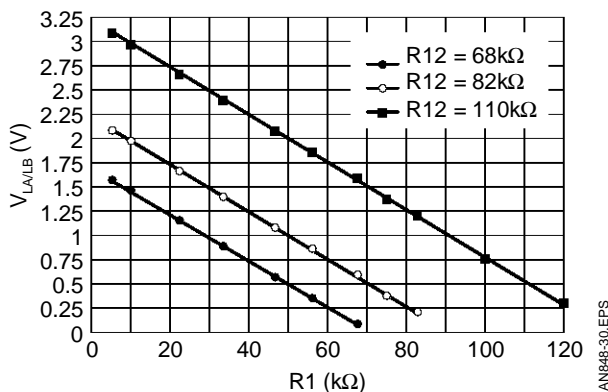

Figure 29 gives the maximum transmit level at Pin  $V_L$  (Pin 3) versus  $R_1$ , for  $R_3 = 2.7k\Omega$  & for different values of  $R_{12}$ , at  $I_L = 40mA$ .

Figure 29 : Vac Max On Line



II.3.3 - Line Loss Compensation/ A.G.C. Adjustment

The TEA7092 uses a line current information to control the transmit and receive gains variation versus the line current.

The Automatic Gain Control (A.G.C.) versus line length works in the same way for transmit and receive paths.

Through two external resistors the line current variation, where the A.G.C. occurs, is programmable :

-  $R_{18}$  connected on Pin  $I_{LL}$  (Pin 33) sets up the start up line current value,  $I_{LL}$ , for the A.G.C.

$$R_{18} = \frac{300}{I_{LL} - 5.6} \text{ in } k\Omega ; I_{LL} \text{ in mA}$$

-  $R_{19}$  connected on Pin  $I_{SL}$  (Pin 34) sets up the slope and the line current value,  $I_{SL}$ , where the

transmit and receive gains are equal to the maximum gain value minus 6dB.

$$R_{19} = \frac{300}{I_{SL} - 5.6} \text{ in } k\Omega ; I_{SL} \text{ in mA}$$

For line current values lower than  $I_{LL}$ , the transmit and receive gains stay at their maximum values.

For line current values upper than  $I_{SL}$ , the transmit and receive gains stay at their minimum values.

Figure 30 gives A.G.C. with a constant start value ( $I_L = 20mA$ ) and different values of  $R_{19}$ .

Figure 31 gives A.G.C. with a constant stop value ( $I_L = 100mA$ ) and different values of  $R_{18}$ .

Figure 30 :  $dG_{Tx} = f(I_L)$

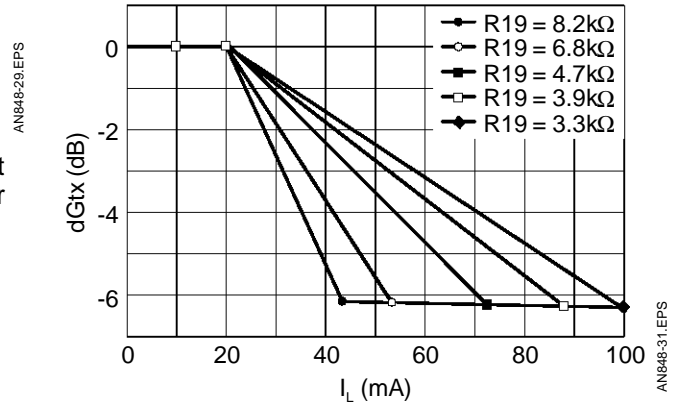
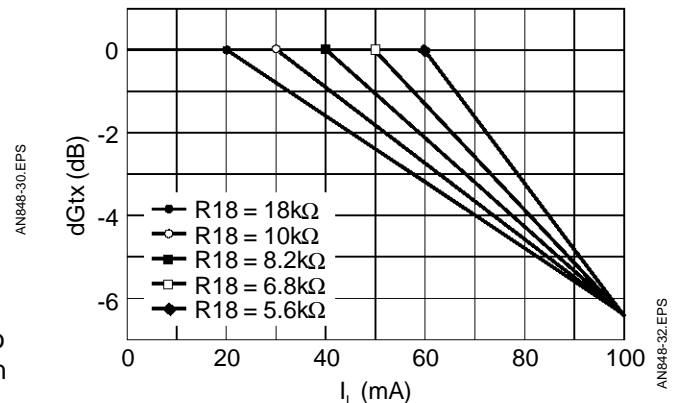

Figure 31 :  $dG_{Tx} = f(I_L)$



II.3.4 - A.G.C. Inhibition

The A.G.C. feature can be inhibited through the serial bus interface by sending the code 0010100. This code is a toggle one.

When the no A.G.C. mode is selected the transmit and receive gains stay at their maximum values -2dB over the line current range variation.

This feature is used for a telephone set connected behind a PABX or in a country where the A.G.C. feature is not requested.

# TEA7092 - TELEPHONE SET INTEGRATED CIRCUIT

## II - SPEECH FEATURES (continued)

### II.3.5 - Transmit Squelch / Antiacoustic Feedback Stage

Figure 32 : Block Diagram

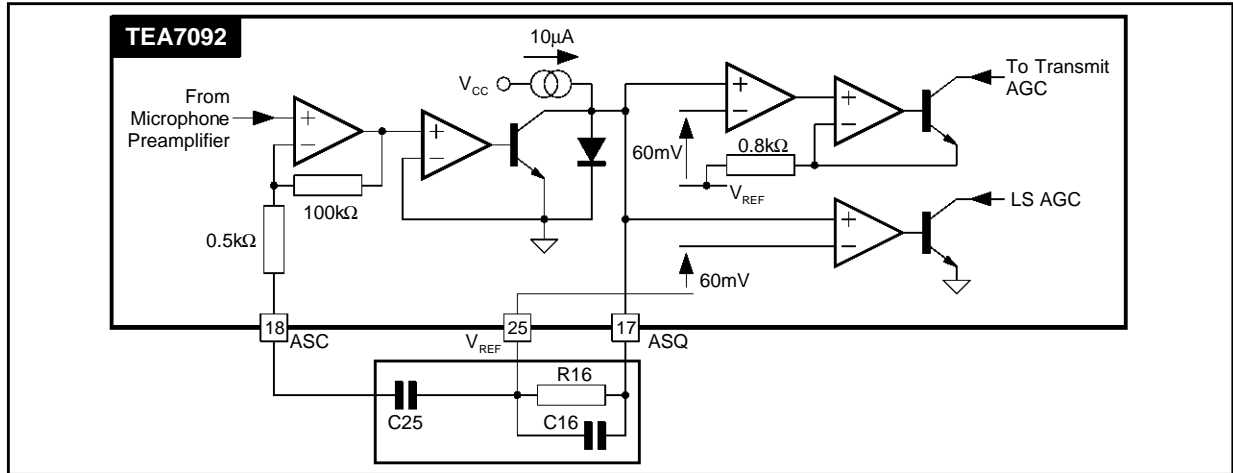
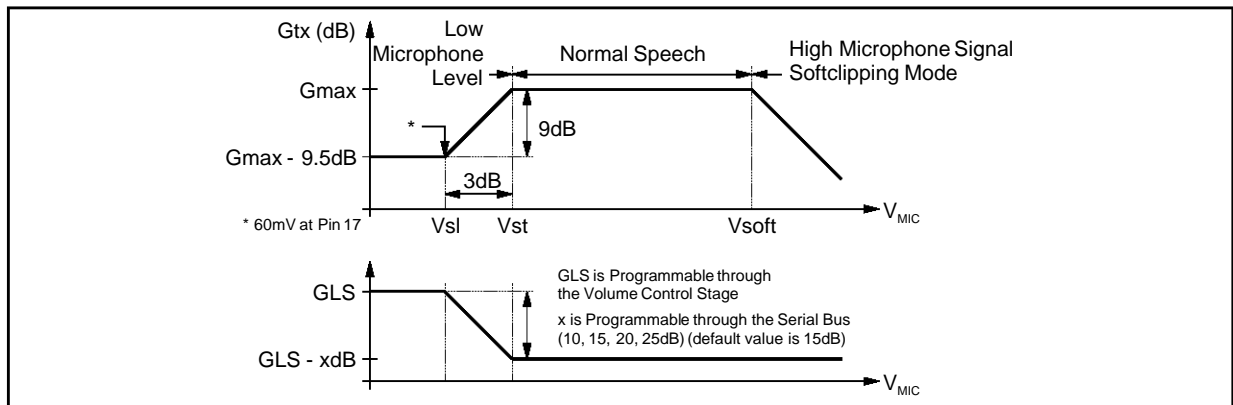

Figure 33



The same stage is used for the transmit squelch and the antiacoustic feedback feature which is used in loudspeaking mode. Figure 32 shows the block diagram of this stage.

When there is no signal on the handset microphone inputs, the transmit gain is reduced by 9dB, refer to the maximum gain, and the loudspeaker amplifier is at the gain value set by the volume control stage, (see Section III - CALL PROGRESS MONITOR AND GROUP LISTENING MODES). When the handset microphone signal is present and increases progressively, it describes the first curve in Figure 33 and the loudspeaker amplifier describes the second curve in Figure 33. The attenuation of the loudspeaker amplifier for the antiacoustic feature is programmable from 10dB to 25dB through the serial bus interface, the default value is 15dB. The squelch threshold feature can be inhibited through the serial bus interface by sending the code (0011001) without affecting the antiacoustic feedback control. This code is a toggle one. The squelch threshold level

is adjustable through the C25 capacitor value connected at Pin ASQ (Pin 18). Be aware that when the threshold level is modified, the cut-off frequency of the filter is also modified. The squelch threshold level is determined by the microphone level injected at Pins MIC1 & MIC2 (Pins 23 & 24). Figure 34 gives the threshold level with a maximum transmit gain of 44dB.

Figure 34 : Squelch Threshold ( $I_L = 20mA/f_{MIC} = 1kHz$ )

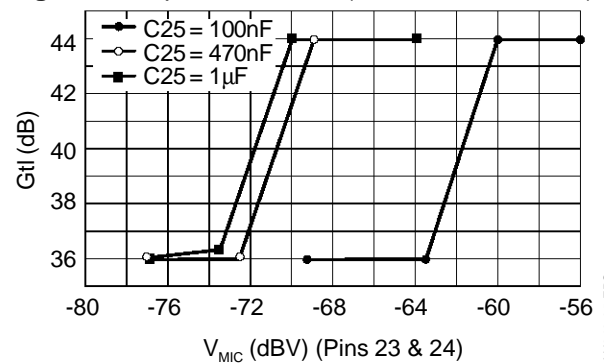

II - SPEECH FEATURES (continued)

II.4 - Sidetone

II.4.1 - General Information

The sidetone uses the wheatstone bridge principle (see Figure 35). Figure 36 shows the block diagram of the sidetone stage.

TEA7092 integrates a line tracking sidetone network which uses two sidetone networks.

One sidetone network, ZALL, is optimized for a long line length connection and the other one, ZASL, is optimized for a short line length connection. An internal mixer stage uses a line current information, kIL, to smooth linearly from ZALL to ZASL with the following equation :

$$ZAL = k \times ZALL + (1 - k) \times ZASL$$

$k = 1$  for  $I_L = I_{LL}$ ,  $k = 0$  for  $I_L = I_{SL}$  and  $k$  varied linearly between 1 and 0 when the line current varied from  $I_{LL}$  to  $I_{SL}$ .

Like this, the sidetone is optimized for every line length.

This concept can be suppressed by shortcircuiting the two sidetone inputs, Pin SNLL (Pin 16) and Pin SNSL (Pin 15) and to connect only one sidetone network, in this case the sidetone is only optimized for one line length, as a standard one, and the efficiency of the sidetone is lower on all the other line length connections.

Figure 35

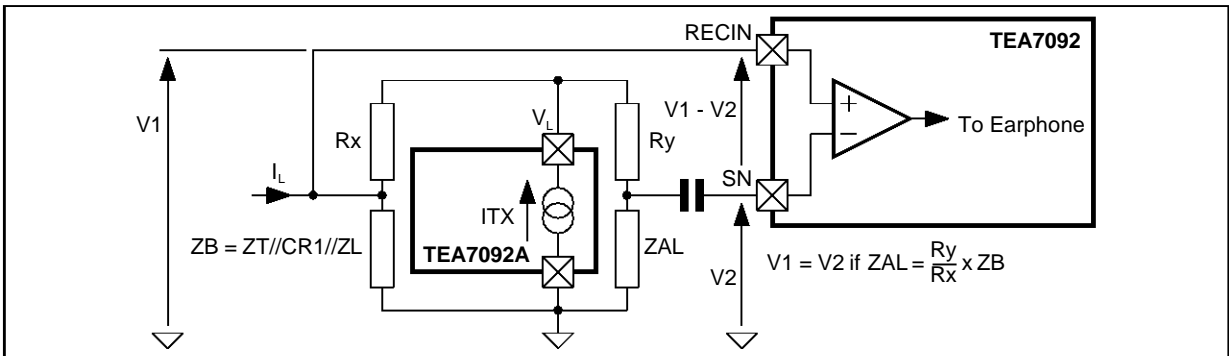

AN848-36.EPS

Figure 36

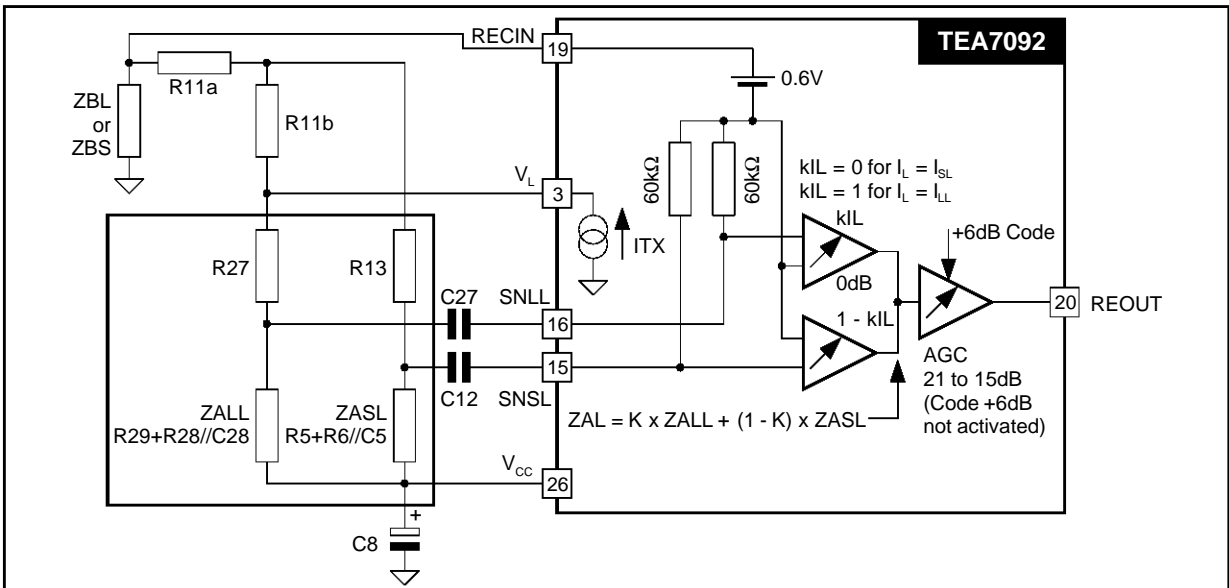

AN848-37.EPS

II - SPEECH FEATURES (continued)

II.4.2 - One Sidetone Network Principle

Figure 37 gives the sidetone connection.

Figure 37

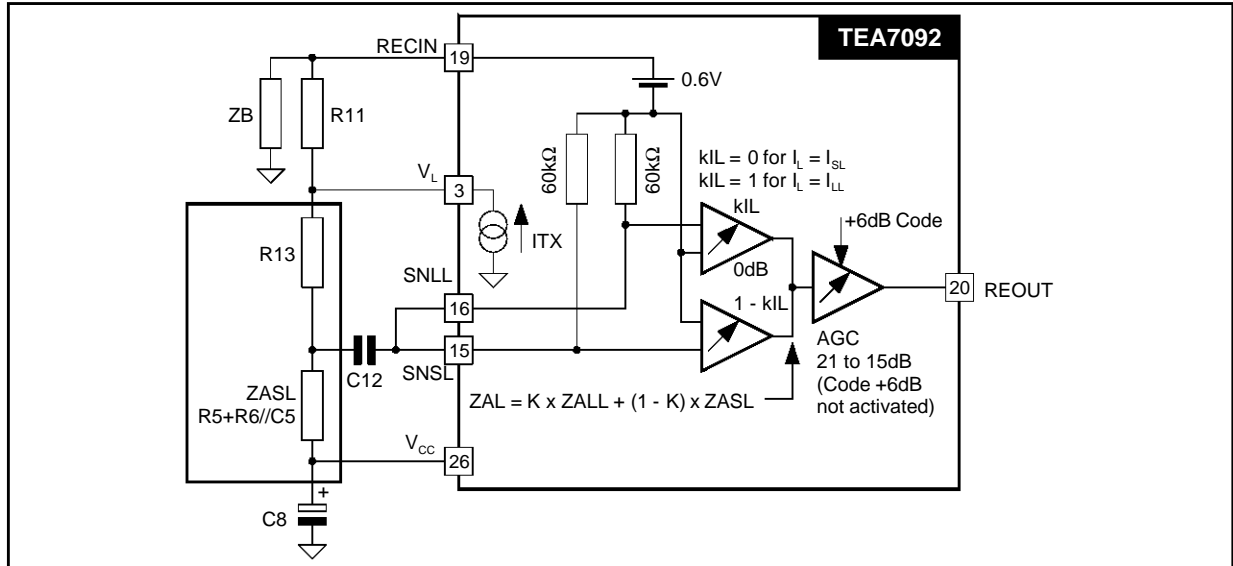

The sidetone is optimized if :

$$V1 - V2 = V_{RECIN(19)} - V_{SNSL/SNLL(15/16)} = 0$$

$$ZAL = \frac{R27}{R11} \cdot ZB$$

With  $ZB = ZT//CR1//ZL$ .

Figure 38 gives the sidetone efficiency versus the line length.

Figure 38

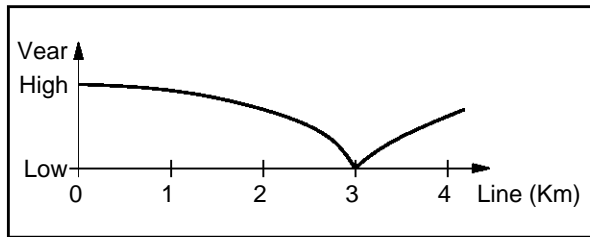

In receive mode the signal V1-V2 is amplified through the receive path.

The attenuation due to the external components of the sidetone stage is :

$$G_{sid} = \frac{V1 - V2}{v1} = \frac{R11 + R27}{R11 + R27 + ZAL}$$

If,  $R27 = K1 \times R11$  and  $K1 \gg 1$  :

$$G_{sid} = \frac{V1 - V2}{v1} = \frac{R11}{R11 + ZB}$$

The sidetone attenuation is proportional to R11 and ZB.

II.4.3 - Line Tracking Sidetone Principle

Figure 39 gives the sidetone connection.

The sidetone are optimized if :  $V1 - V2 = 0$

- On long line connection :

$$V1 - V2 = V_{RECIN(19)} - V_{SNLL(16)} = 0$$

$$\Rightarrow ZALL = \frac{R27}{R11a + R11b} \cdot ZBL$$

with  $ZBL = ZT//CR1//ZLL$ .

- On short line connection :

$$V1 - V2 = V_{RECIN(19)} - V_{SNSL(15)} = 0$$

$$\Rightarrow ZASL = \frac{R13}{R11a} \cdot ZBS$$

with  $ZBS = ZT//CR1//ZSL$ .

ZLL is the long line length impedance and ZSL is the short line length impedance.

Figure 40 gives the sidetone efficiency versus the line length for a one sidetone network principle and a tracking sidetone network principle.

II - SPEECH FEATURES (continued)

II.4 - Sidetone (continued)

Figure 39

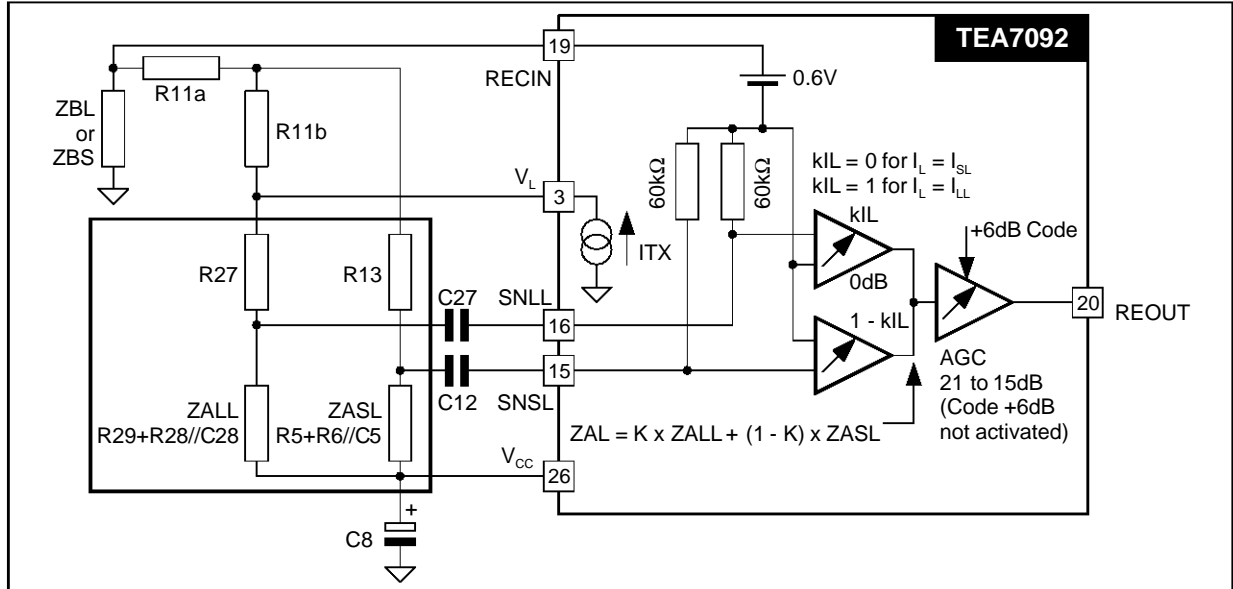
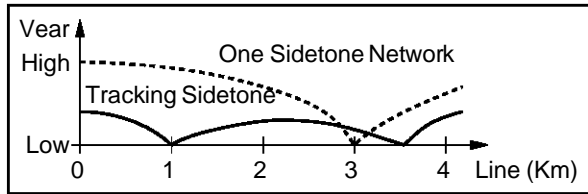

Figure 40



In receive mode the signal V1-V2 is amplified through the receive path.

The attenuation due to the external components of the sidetone stages are :

- For a line current equivalent to a long line connection :

$$G_{sid(l)} = \frac{V1 - V2}{V1} = \frac{R11a + R11b + R27}{R11a + R11b + R27 + ZALL}$$

If,  $R27 = K1 \times (R11a + R11b)$  and  $K1 \gg 1$  :

$$G_{sid(l)} = \frac{V1 - V2}{V1} = \frac{R11a + R11b}{R11a + R11b + ZBL}$$

The sidetone attenuation is proportional to  $(R11a + R11b)$  and ZBL.

- For a line current equivalent to a short line connection :

$$G_{sid(s)} = \frac{V1 - V2}{V1} = \frac{R11a + R13}{R11a + R13 + ZASL}$$

If,  $R13 = K1 \times R11a$  and  $K1 \gg 1$  :

$$G_{sid(s)} = \frac{V1 - V2}{V1} = \frac{R11a}{R11a + ZBS}$$

The sidetone attenuation is proportional to R11a and ZBS.

R11a and R11b should be calculated to have the same attenuation due to the two sidetone networks. In this way the complete receive channel gain is fixed on Pin GREC (Pin 43) and in A.G.C. mode the receive gain is reduced by 6dB between  $I_{LL}$ , line current for a long line connection, and  $I_{SL}$ , line current for a short line connection.

If an application requests less or more than 6dB on the complete receive channel, the values of R11a and R11b will be adapted to it.

II.4.4 - Sidetone Programming for PABX Application

When the tracking sidetone network is used, it is possible to inhibit it through the serial bus interface. This principle suppresses the switches existing in a telephone set, when this one can be indifferently connected to a public exchange or a private exchange. When it is connected on a public exchange the tracking sidetone network is used. When it is connected on a private exchange the tracking sidetone network is inhibited, internally the kIL information which controls the sidetone mixer stage is fixed independently of the line current value, and can take two values :

- By sending the code 0011000, the sidetone network is equivalent to :

$$ZAL = \frac{3}{4} \cdot ZALL + \frac{1}{4} \cdot ZASL$$

- By sending the code 0011011, the sidetone network is equivalent to :  $ZAL = ZASL$

# TEA7092 - TELEPHONE SET INTEGRATED CIRCUIT

## II - SPEECH FEATURES (continued)

### II.5 - Receive Channel

#### II.5.1 - General Information (Maximum Gain Adjustment)

The receive path amplifies several signals :

- The line signal to the earphone with an intermediate output, Pin REOUT (Pin 20) so as to use this signal as an input for the loudspeaker amplifier or for a handfree circuit such as TEA7540.
- The DTMF sinewave as a confidence tone level.
- The waiting melody sinewave as an earphone level control.

At one time, only one of these signals is amplified, the choice is made through the serial bus interface with the microcontroller.

Figure 41 shows the receive channel block diagram.

The signal VRECIN - VSNLL or VRECIN - VSNSL or a combination of both is amplified to the earphone outputs.

As described in Section II.4.2 and Section II.4.3 the signal V1 is attenuated through the sidetone network. After this attenuation, the received signal is amplified by the Sidetone mixer and A.G.C. stages with an amplification, of 21dB on a long line length,  $I_{LL}$ , which is the maximum receive gain, and of 15dB on a short line length,  $I_{SL}$ , when the A.G.C. feature is used. The final gain adjustment is done on Pin GREC (Pin 20) by adjusting R14 and R17 values.

Figure 41

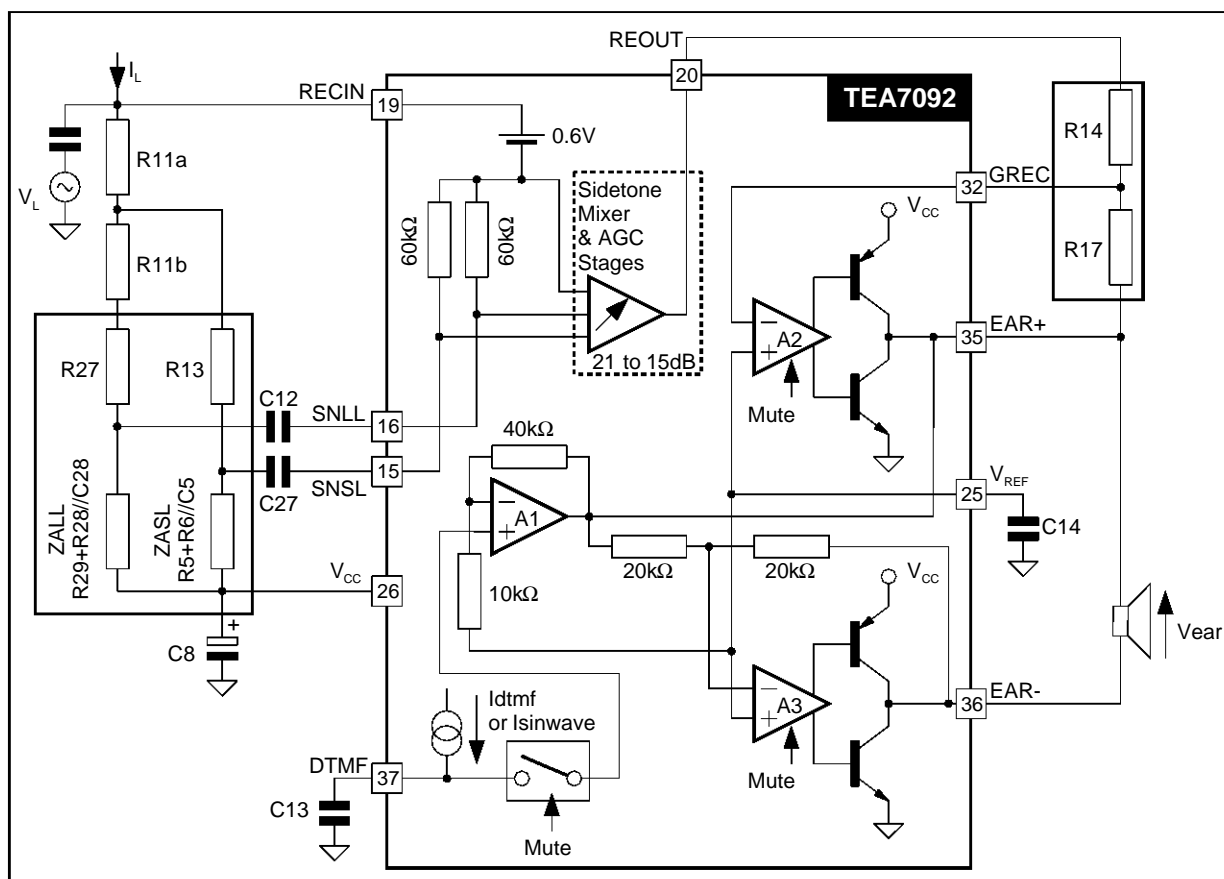

AN848-42.EPS

II - SPEECH FEATURES (continued)

II.5 - Receive Channel (continued)

The gain between Pin RECIN (Pin 19) and the earphone outputs, Pin EAR+ (Pin 35) and Pin EAR- (Pin 36) is :

- With tracking sidetone and A.G.C. features, earphone connected in symmetric mode :

- On long line,  $I_L = I_{LL}$ , maximum gain

$$Gr(dB) = 20 \cdot \log \frac{V_{ear}}{V_L}$$

$$= 20 \cdot \log(G_{sid(l)}) + 21dB + 20 \cdot \log \left( 2 \cdot \frac{R17}{R14} \right)$$

- On short line,  $I_L = I_{SL}$ , minimum gain

$$Grs(dB) = 20 \cdot \log \frac{V_{ear}}{V_L}$$

$$= 20 \cdot \log(G_{sid(s)}) + 15dB + 20 \cdot \log \left( 2 \cdot \frac{R17}{R14} \right)$$

- With One sidetone network and A.G.C. features, earphone connected in symmetric mode :

- On long line,  $I_L = I_{LL}$ , maximum gain

$$Gr1(dB) = 20 \cdot \log \frac{V_{ear}}{V_L}$$

$$= 20 \cdot \log(G_{sid}) + 21dB + 20 \cdot \log \left( 2 \cdot \frac{R17}{R14} \right)$$

- On short line,  $I_L = I_{SL}$ , minimum gain

$$Grs1(dB) = Gr1 - 6dB$$

It is possible to use only one output, asymmetric mode, in this case all the receive gain are reduced by 6dB.

Figure 42 shows the asymmetric connection.

**Note :** Due to the concept used to power supply the earphone through the impedance network (R10) and with the  $V_{CC}$  supply, it is preferable to connect the earphone in asymmetric mode if the earphone impedance is less than  $300\Omega$ , and in symmetric mode if the earphone impedance is more than  $300\Omega$ . More details are given in the following paragraph.

II.5.2 - Maximum Output Level

The maximum output level depends on several parameters :

- The DC level on Pin  $V_L$  (Pin 3).
- The impedance network value connected between Pin RECIN (Pin 19) and Pin  $V_{CC}$  (Pin 26).
- The earphone impedance value.

Figure 43 shows the earphone amplifier supply principle.

Without AC signal the voltage at Pin  $V_{CC}$  (Pin 26) is :

$$V_{CC} = V_L + R11a/b \times I_L - (R10 + R11a/b) \times I_P$$

The value at Pin  $V_L$  (Pin 3) depends on R12 (see Section II.1.1).

When an ac signal is amplified, the current driving the earphone,  $I_{ear}$ , flows through R10 and the DC voltage at Pin  $V_{CC}$  (Pin 26) is reduced.

Figure 42

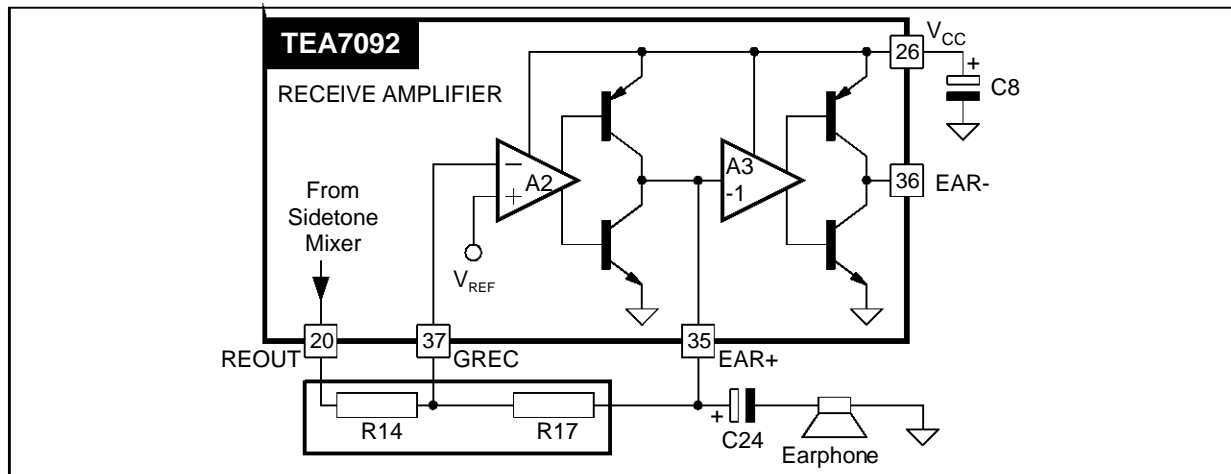

AN848-43.EPS

# TEA7092 - TELEPHONE SET INTEGRATED CIRCUIT

## II - SPEECH FEATURES (continued)

### II.5 - Receive Channel (continued)

Figure 43

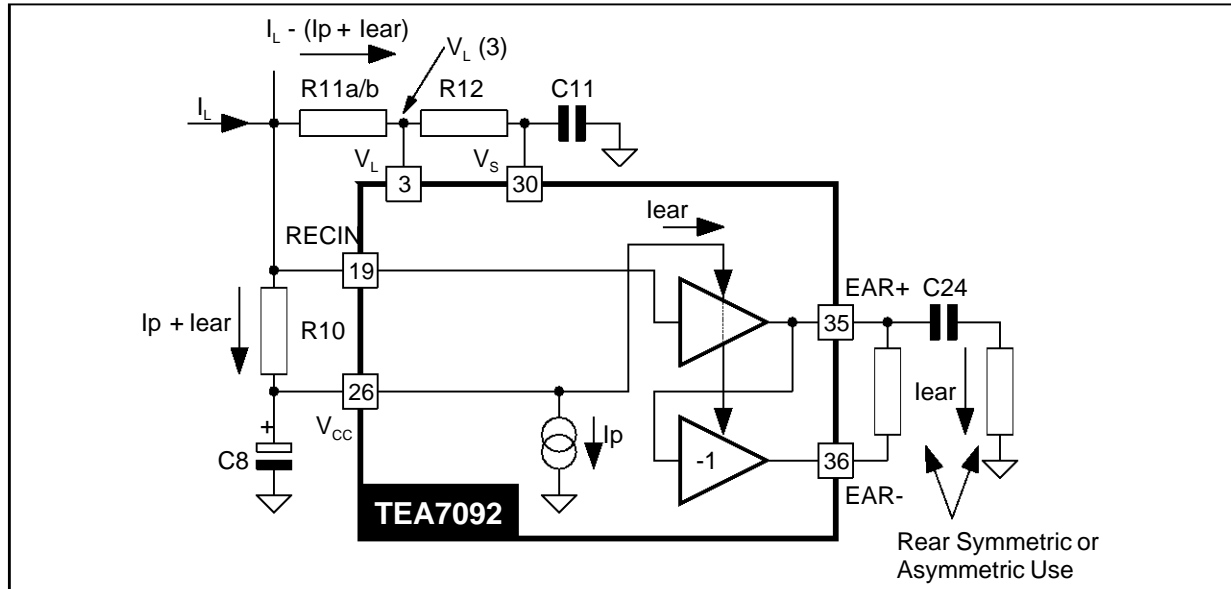

With this principle the maximum output voltage at Pin EAR+ (Pin 35) and Pin EAR- (Pin 36), depending on the application, is limited in current and in voltage in the following way :  $R11 = R11a + R11b$

$I_p = 1.3\text{mA}$  at  $I_L = 20\text{mA}$

$I_p = 1.7\text{mA}$  at  $I_L = 60\text{mA}$  (see Figure 21).

$$V_{\text{RECIN}} = V_L(3) + R11 \times (I_L - I_p - I_{\text{EAR}}) \text{ and } V_{\text{CC}} = V_{\text{RECIN}} - R10 \times (I_p + I_{\text{EAR}})$$

- In asymmetric use; Earphone ( $R_{\text{EAR}}$ ) connected on Pin EAR+ (Pin 35).

$$V_{\text{CC}} = 2 \times V_{\text{EAR(peak)(Max.)}} + 0.4$$

$$V_{\text{EAR(RMS)}} = \frac{\pi \cdot R_{\text{EAR}} \cdot I_{\text{EAR}}}{\sqrt{2}}$$

$V_{\text{EAR(RMS) (Max.)}}$  in  $V_{\text{RMS}}$  :

$$V_{\text{EAR(RMS) (Max.)}} = \frac{\pi \cdot R_{\text{EAR}}}{\sqrt{2} \cdot (2\pi \cdot R_{\text{EAR}} + R10 + R11)} \cdot [V_L + R11 \cdot I_L - (R10 + R11) \cdot I_p - 0.4]$$

- In symmetric use; Earphone ( $R_{\text{EAR}}$ ) connected between Pin EAR+ (Pin 35) & Pin EAR- (Pin 36).

$$V_{\text{CC}} = V_{\text{EAR (peak)(Max.)}} + 0.2$$

$$V_{\text{EAR(RMS)}} = \frac{\pi \cdot R_{\text{EAR}} \cdot I_{\text{EAR}}}{2 \cdot \sqrt{2}}$$

$V_{\text{EAR(RMS) (Max.)}}$  in  $V_{\text{RMS}}$  :

$$V_{\text{EAR(RMS) (Max.)}} = \frac{\pi \cdot R_{\text{EAR}}}{\sqrt{2} \cdot (\pi \cdot R_{\text{EAR}} + 2 \cdot (R10 + R11))} \cdot [V_L + R11 \cdot I_L - (R10 + R11) \cdot I_p - 0.2]$$

**Notes :** 1. In few applications, at low line current ( $I_L < 20\text{mA}$ ) and depending on the DC voltage at Pin  $V_L$  (Pin 3), the absolute minimum value of  $V_{\text{CC}}$ , 2V, should be taken into account in the calculation of  $V_{\text{EAR(RMS)(Max.)}}$ . This limitation happens if :  $I_L = 20\text{mA}$ ,  $R12 = 68\text{k}\Omega$  and  $R10 = 1200\Omega$  (complex impedance DC value).

2. Usually, when the impedance of a transducer, Rear, increases, the efficiency of the transducer in dB SPL/V decreases. The receive gain is adapted to the earphone impedance to offset this transducer's efficiency change, so that the complete acoustical gain of the receive path remains constant.

II - SPEECH FEATURES (continued)

II.5 - Receive Channel (continued)

Table 2

	Asymmetric		Symmetric	
	R <sub>EAR</sub> = 150Ω	R <sub>EAR</sub> = 300Ω	R <sub>EAR</sub> = 600Ω	R <sub>EAR</sub> = 1kΩ
R17	33kΩ	68kΩ	68kΩ	120kΩ
C17	680pF	330pF	330pF	220pF

The Table 3 gives the value of V<sub>EAR(RMS)</sub>(Max.), at I<sub>L</sub> = 20mA & I<sub>L</sub> = 60mA, for different values of, R12 (68kΩ, 82kΩ, 110kΩ), R10 (680Ω, 1200Ω to simulate a complex impedance), R<sub>EAR</sub> (150Ω, 300Ω in asymmetric mode ; 600Ω, 1kΩ in symmetric mode) and a distortion level at 2% and 10%.

Table 3

I <sub>L</sub>	R10	R12	D (%)	Earphone Output Level (V <sub>RMS</sub> )			
				150Ω (A)	300Ω (A)	600Ω (S)	1kΩ (S)
20mA	680Ω	68kΩ	2	0.45	0.77	1.2	1.5
			10	0.51	0.85	1.3	1.6
		82kΩ	2	0.45	0.9	1.4	1.8
			10	0.51	0.96	1.52	1.92
		110kΩ	2	0.46	0.98	1.91	2.4
			10	0.51	1.1	2	2.56
	1200Ω	68kΩ	2	0.26	0.52	0.59	0.95
			10	0.29	0.57	0.61	0.97
		82kΩ	2	0.39	0.64	0.87	1.25
			10	0.42	0.69	0.89	1.33
		110kΩ	2	0.46	0.89	1.32	1.65
			10	0.5	0.95	1.37	1.8
60mA	680Ω	68kΩ	2	0.28	0.6	1.2	2.3
			10	0.32	0.69	1.4	2.5
		82kΩ	2	0.28	0.6	1.25	2.3
			10	0.32	0.69	1.42	2.5
		110kΩ	2	0.29	0.62	1.27	2.3
			10	0.32	0.7	1.44	2.6
	1200Ω	68kΩ	2	0.28	0.6	1.23	1.9
			10	0.32	0.69	1.4	1.98
		82kΩ	2	0.28	0.6	1.25	2.15
			10	0.32	0.69	1.33	2.3
		110kΩ	2	0.29	0.62	1.28	2.3
			10	0.33	0.7	1.45	2.6

The sidetone mixer stage has a limiter to avoid acoustic signal higher than 120 dBSPL on the earphone.

**Example :** Electrodynamic transducer : 150Ω / 122 dBSPL/V

- R10 = 680Ω ;

- At I<sub>L</sub> = 20mA : V<sub>EAR(Max.)</sub> = 0.51V<sub>RMS</sub> ⇒ 116.2 dBSPL
- At I<sub>L</sub> = 60mA : V<sub>EAR(Max.)</sub> = 0.33V<sub>RMS</sub> ⇒ 112.4 dBSPL

If this acoustic limitation is too low, it is possible to modify it by :

- Decreasing the gain of the sidetone attenuation = Decrease R11a & R11b. (R13 & R27 should also be modified).
- Increasing the gain on Pin GREC (Pin 37), to maintain the same total receiving gain ⇒ Increase R17.

# TEA7092 - TELEPHONE SET INTEGRATED CIRCUIT

## II - SPEECH FEATURES (continued)

### II.5.3 - Line Loss Compensation / A.G.C. Adjustment

The characteristics of the A.G.C. stage in the receive path are the same as those in the transmit path.

For more information see Section II.3.3.

### II.5.4 - A.G.C. Inhibition

The characteristics of the A.G.C. inhibition stage in the receive path are the same as those in the transmit path.

For more information see Section II.3.4.

### II.5.5 - +6dB Mode

Through the serial bus interface, it is possible to

increase the receive gain amplifier by 6dB.

This code (0010110) is a toggle code.

## II.6 - Handsfree Interface

Figure 44 shows the interconnection between TEA7092 and Handsfree circuit such as TEA7540.

TEA7092 should be in Handsfree mode (0110010).

The Handsfree circuit is supplied through the Pin V<sub>LS</sub> (Pin 1)

In this mode the signal injected on Pin HFIN (Pin 22) is amplified, the antiacoustic feedback stage is inhibited and the loudspeaker amplifier is activated.

The receive path of the Handsfree circuit is inserted between Pin REOUT (Pin 20) and Pin LSIN (Pin 5).

Figure 44

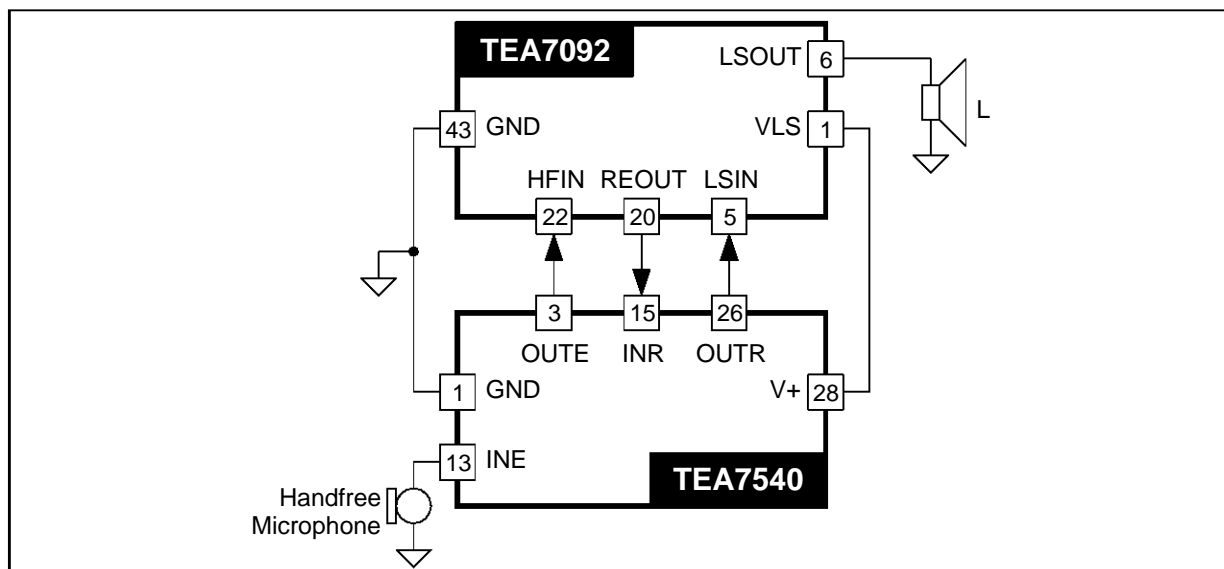

AN848-45.EPS

III - CALL PROGRESS MONITOR AND GROUP LISTENING MODES

III.1 - General Information

The Call Progress Monitor and Group Listening modes are OFF-HOOK modes with the loudspeaker being used.

The Call Progress Monitor, or "ON-HOOK dialing" is an OFF-HOOK mode where the line is taken through a dedicated key which closes the line without using the handset. In this mode only the loudspeaker is enabled, to hear the different tones coming from the exchange. As soon as the handset is off-hook the loudspeaker is disabled and no longer used. In Call Progress Monitor, the handset microphone is muted and the anti-acoustic feature is disabled.

The group listening mode is an OFF-HOOK mode where the handset and the loudspeaker are simultaneously used. The receive signal can be heard in the earphone and in the loudspeaker. In Group listening mode, the anti-acoustic or anti-howling feature is enabled to prevent any feedback from the handset microphone to the loudspeaker which can cause howling effect.

Figure 45 shows the loudspeaker amplifier path.

The signal coming from Pin REOUT (Pin 20), intermediate receive output, is injected into the loudspeaker amplifier on Pin LSIN (Pin 5). Between pin

REOUT (Pin 20) and Pin LSIN (Pin 5) a filter can be added to offset the loudspeaker frequency response curve. The loudspeaker is connected on Pin LSOUT (Pin 44). The maximum gain between Pin LSIN (Pin 5) and Pin LSOUT (Pin 44) is 34dB.

When a handsfree circuit is used, its receive path is connected between Pin REOUT (Pin 20) and Pin LSIN (Pin 5).

The loudspeaker amplifier, as described in Figure 45, is controlled by the following signals :

- LS AGC from the anti-acoustic feedback stage which attenuates the loudspeaker amplifier gain when the handset microphone level goes upper the threshold to avoid howling effect.
- Pin LSSOFT (Pin 6) which attenuates the loudspeaker amplifier gain, to drive properly the loudspeaker when the LSOUT output reaches the saturation of the output stage compared to  $V_{LS}$  or the ground, through  $V_{PP}(LSOUT)$  information. This information acts as a softclipping stage, so the gain is reduced without any distortion.
- The volume control stage adjusts, by 4dB step, the loudspeaker amplifier gain, with a maximum depth of 28dB.

**Note :** In default mode, the gain of the volume control stage is equal to  $G_{max} - 28dB$ .

Figure 45

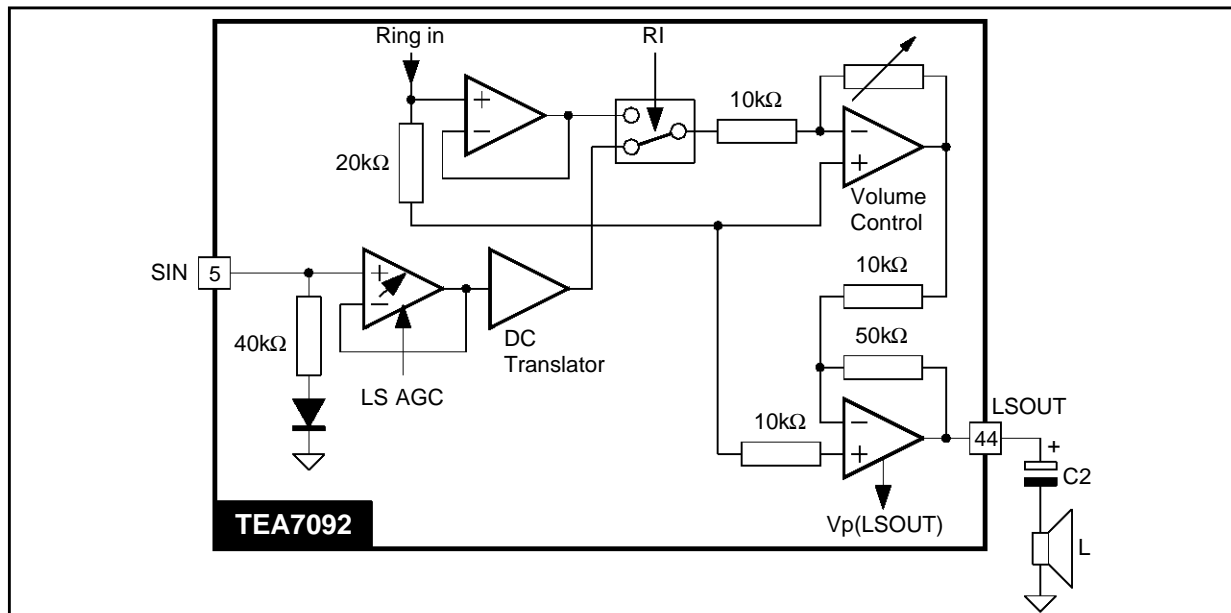

AN848-46.EPS

III - CALL PROGRESS MONITOR AND GROUP LISTENING MODES (continued)

Figure 46

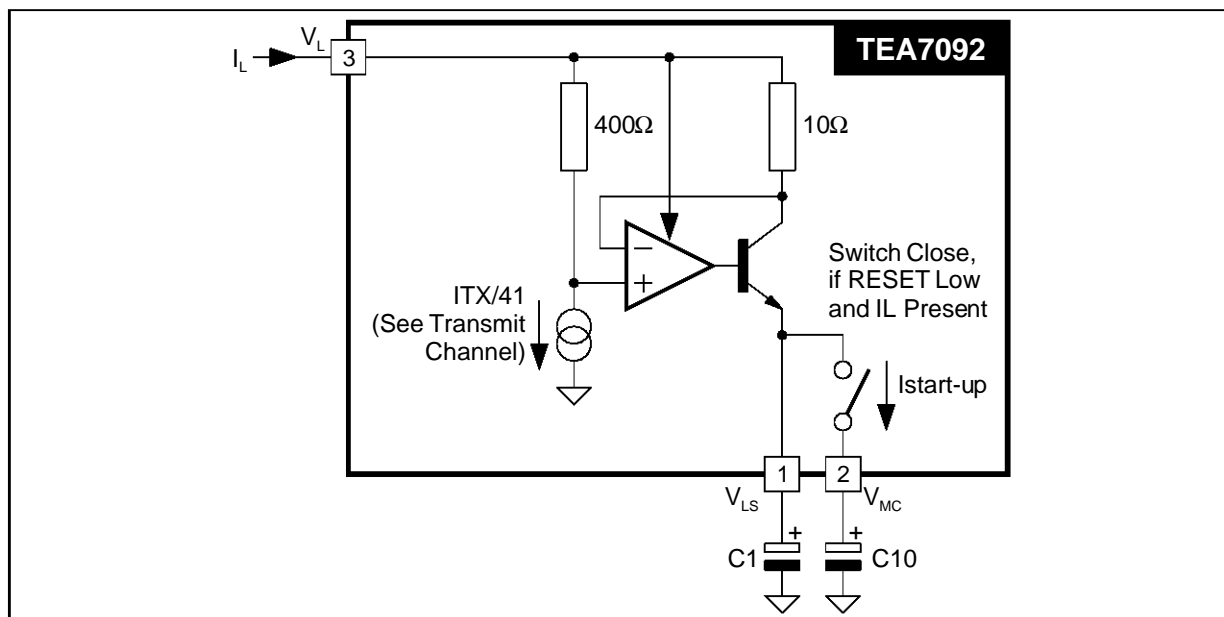

III.2 - Loudspeaking Part Supply

The loudspeaking part is powered on Pin  $V_{LS}$  (Pin 1).

The final stage of the transmit path is simultaneously used to amplify the transmit signal and to power supply the loudspeaking part.

Figure 46 shows the loudspeaking part supply.

After an OFF-HOOK action, during the start-up period and still the microcontroller reset is low, the current power supply of the loudspeaking part is used to charge quickly the capacitor C10 on pin  $V_{MC}$  (Pin 2), capacitor which is used to power supply the microcontroller.

Figure 47 shows the line current,  $I_L$ , partition in the different paths of the TEA7092.

- $I_{LS}$  : Current available for the loudspeaker part and other peripherals.

- $I_{VMC}$  : Current for the microcontroller power supply.
- $I_{VCC}$  : Speech part current consumption.

Other peripherals like a handsfree circuit or discrete CMOS logic can be powered on Pin  $V_{LS}$  (Pin 1).

Figure 47

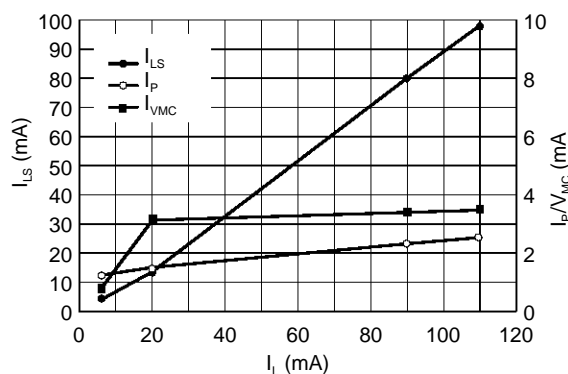

III - CALL PROGRESS MONITOR AND GROUP LISTENING MODES (continued)

III.3 - Softclipping Stage

The softclipping stage avoids distortion on the loudspeaker output LSOUT (Pin 44) over a range of input signals on Pin LSIN (Pin 5).

Figure 48 shows the loudspeaker softclipping stage.

The softclipping stage avoids distortion when there is not enough DC supply voltage on Pin V<sub>LS</sub> (Pin 1). This is done by detecting the saturation on the Pin LSOUT (Pin 44) compared to Pin V<sub>LS</sub> (Pin 1) - 0.2V and GND + 0.2V. When one of these two voltages is reached, the DC voltage on Pin LSSOF (Pin 6) increases and the loudspeaker amplifier gain is reduced through the V<sub>PP</sub>(LSOUT) signal control.

III.4 - Antiacoustic Feedback Features

The same stage is used to control the antiacoustic feedback stage, to avoid howling effect, than to control the squelch stage.

Figure 49 shows the antiacoustic feedback and squelch stage.

In group listening mode, when the handset and the loudspeaker are simultaneously used, it is necessary to avoid howling effect between the handset microphone and the loudspeaker.

The antiacousticfeedback stage detects the microphone signal and, if this one is higher than the fixed threshold (60mV), the gain of the loudspeaker is

reduced through LS AGC information.

By default the loudspeaker amplifier gain reduction is fixed at 15dB, this one can be modified through the serial bus interface with the following values :

- 10dB : code (0111100).
- 15dB : code (0111101), equivalent to default mode.
- 20dB : code (0111110).
- 25dB : code (0111111).

These different values allow the adaption of the antiacoustic feedback stage to different telephone sets.

Figure 50 shows the behaviour of the antiacoustic feedback stage (coupled with the squelch feature, if this one is enabled).

The signal microphone is amplified by the first stage with a gain close to 200, and filtering on Pin ASC (Pin 18), the cut off frequency is fixed by C25 and the internal 0.5kΩ.

Recommended values :

C25 = 470nF or 1µF ⇒ f<sub>c</sub> = 677Hz or 318Hz

On Pin ASQ (Pin 17), the rise and decay times are fixed by R16, C16 and the 10µA internal current source.

- Rise time :  $t_R = \frac{C16 \times 60 \times 10^{-3}}{10 \times 10^{-6}}$ ,

with C16 = 1µF ⇒ t<sub>R</sub> = 6ms.

- Decay time : t<sub>D</sub> = R16 × C16,

with R16 = 330kΩ and C16 = 1.5µF ⇒ t<sub>D</sub> = 330ms.

Figure 48

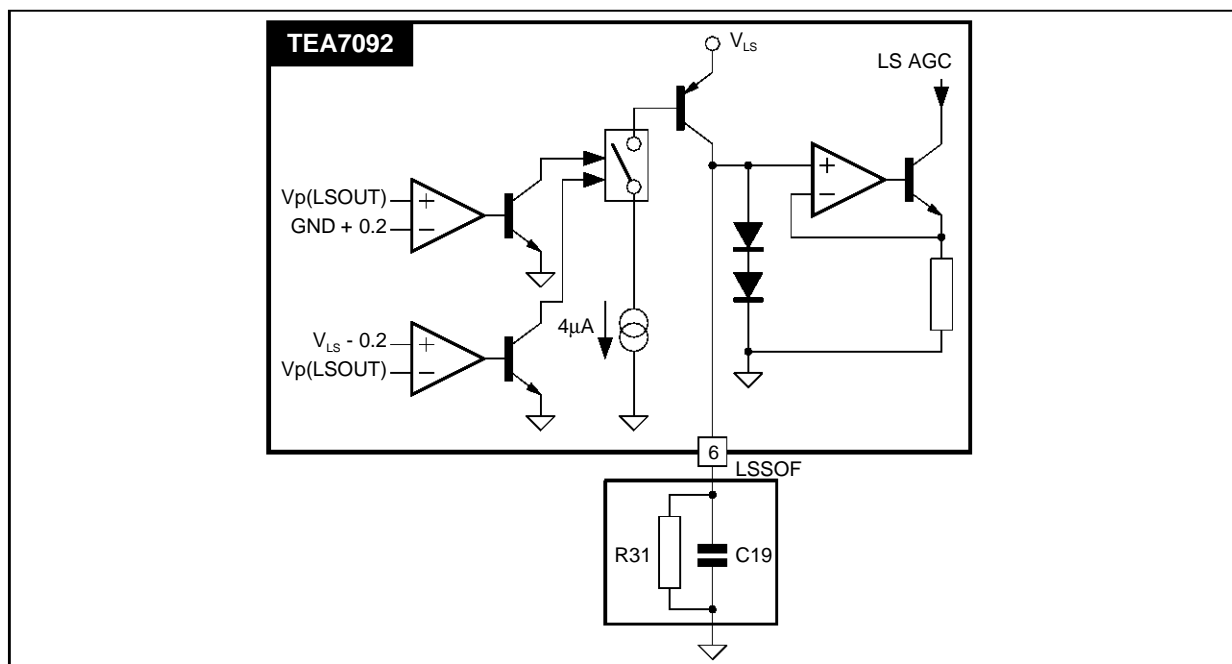

AN848-49/EPS

# TEA7092 - TELEPHONE SET INTEGRATED CIRCUIT

## III - CALL PROGRESS MONITOR AND GROUP LISTENING MODES (continued)

### III.4 - Antiacoustic Feedback Feature (continued)

Figure 49

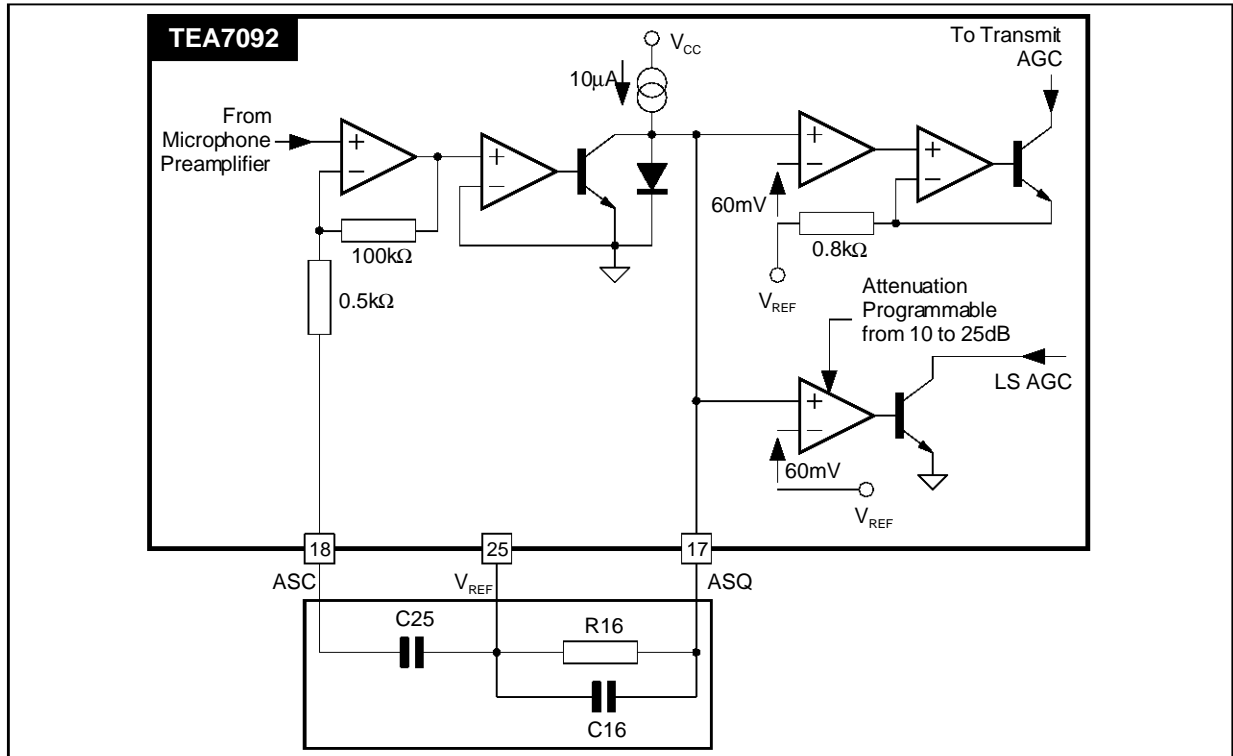

AN848-50.EPS

Figure 50

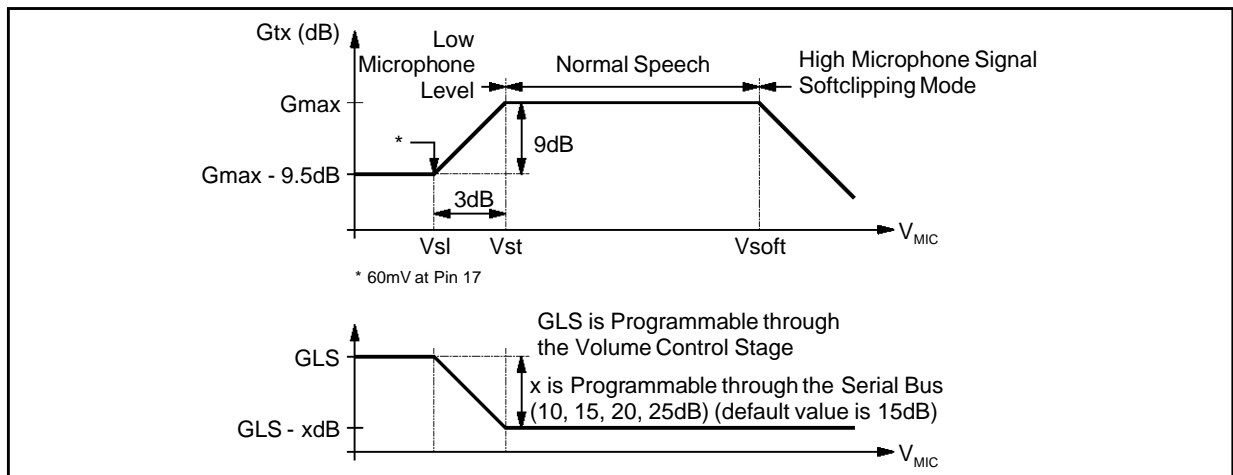

AN848-51.EPS

III - CALL PROGRESS MONITOR AND GROUP LISTENING MODES (continued)

III.5 - Maximum Output Power

The loudspeaker part is powered through the Pin  $V_{LS}$  (Pin 1). The  $V_{LS}$  power could come from the line, Pin  $V_L$  (Pin 3) or an external power supply, +5V for example.

When it is powered from the line, Pin  $V_L$  (Pin 3), the available current,  $I_{LS}$  and the voltage at Pin  $V_{LS}$  (Pin 1) depend on the line current  $I_L$ .

- $V_{LS}$  (Pin 1) =  $V_L$  (Pin 3) - (0.95 + 10 x  $I_{LS}$ )
- $I_{LS} = 0.74 \times I_L - 1.8\text{mA}$  ; if  $I_L < 15\text{mA}$
- $I_{LS} = 0.92 \times I_L - 4.5\text{mA}$  ; if  $I_L > 15\text{mA}$

The current consumption of the loudspeaker amplifier is 1mA, so the current available for the loudspeaker is :  $I_{LS1} = I_{LS} - 1\text{mA}$

Figures 51, 52 and 53 give the maximum power available on the loudspeaker for different loudspeaker impedances (25, 32, 50Ω) and different values of R12 (R12 sets up the DC voltage at Pin  $V_L$  (Pin 3) and the DC voltage at Pin  $V_{LS}$  (Pin 1), thus it has an influence on the maximum power available on the loudspeaker).

When there is enough line current to drive properly the charge on the loudspeaker output, the maximum peak to peak dynamic is :

- On Rloudspeaker = 25Ω :  $V_{PP} = V_{LS} - 1.1\text{V}$
- On Rloudspeaker = 32Ω :  $V_{PP} = V_{LS} - 1\text{V}$
- On Rloudspeaker = 50Ω :  $V_{PP} = V_{LS} - 0.9\text{V}$

Figure 52 : Output Power On LSOUT

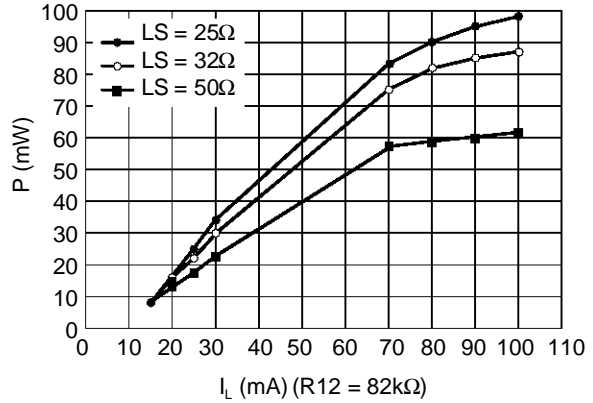

AN848-53.EPS

Figure 51 : Output Power On LSOUT

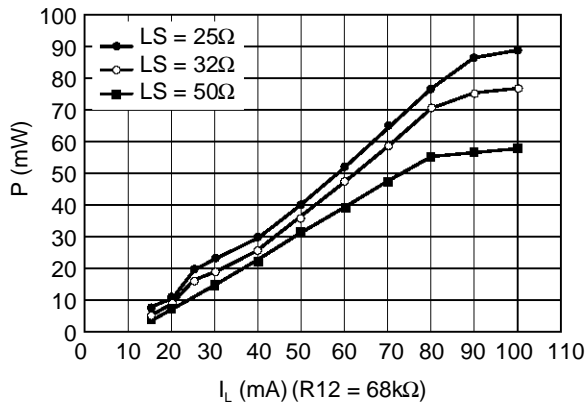

AN848-52.EPS

Figure 53 : Output Power On LSOUT

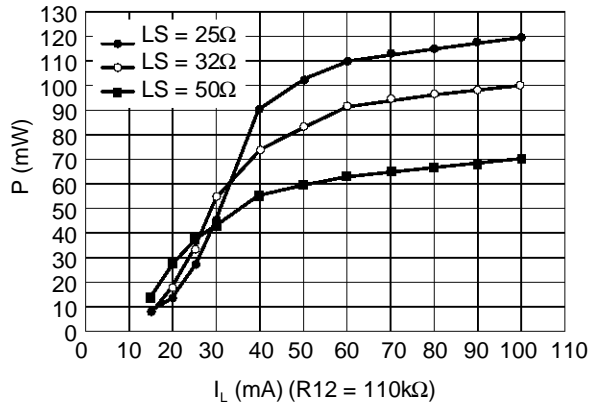

AN848-54.EPS

## TEA7092 - TELEPHONE SET INTEGRATED CIRCUIT

### III - CALL PROGRESS MONITOR AND GROUP LISTENING MODES (continued)

#### III.6 - External Power Supply Facility

Figure 54

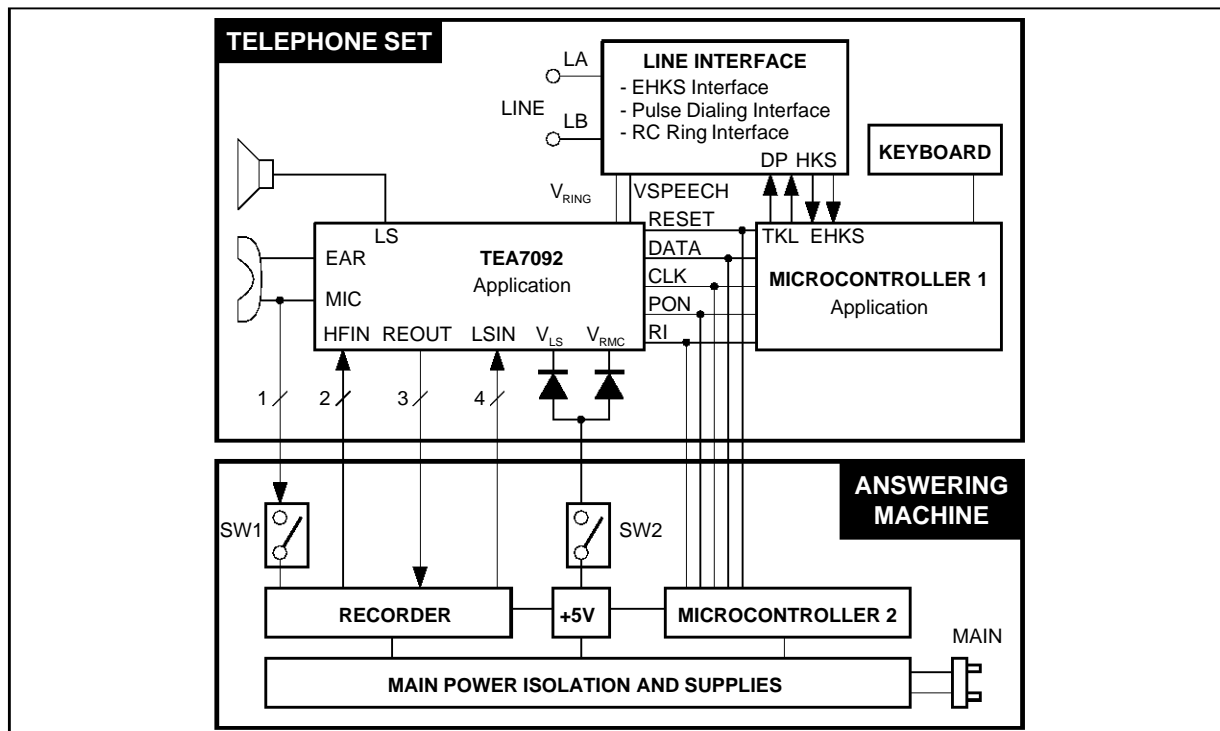

The loudspeaker amplifier can be powered through an external power supply, such as a +5V one.

This external power supply facility allows the use of TEA7092 in a terminal such as an answering machine, a cordless or others, with a direct interface with the +5V external power supply.

Figure 54 shows how to connect the TEA7092 in an answering machine.

The different inputs/outputs are :

- *Line Interface* :
  - LA/LB : line wire terminal
- *Line Interface / TEA7092* :
  - V<sub>RING</sub> : TEA7092 supply in ring mode
  - V<sub>SPEECH</sub> : TEA7092 supply in OFF-HOOK mode
- *Line Interface / Microcontroller 1* :
  - DP : Pulse interface control
  - HKS : Hook switch information
  - EHKS : On-hook dialing or handsfree information
  - TKL :  $\mu$ P line seizure feedback in EHKS mode
- *TEA7092 / Microcontroller 1 / 2* :
  - RESET
  - PON : Line current presence
  - RI : Ring information
  - DATA / CLK : Serial bus interface

- *TEA7092 / Answering Machine* :

- 1) Outgoing message registration ; The line is open, TEA7092 is powered from the +5V and the switch SW1 is closed.
- 2) Outgoing message is sent to the line ; TEA7092 is powered from the line and the outgoing message is sent on Pin HFIN (Pin 22), amplified through TEA7092 and sent to the line.
- 3) Incoming message registration ; TEA7092 is powered from the line and the incoming message is sent to the answering machine through the intermediate receive output, Pin REOUT (Pin 20).
- 4) Incoming message playback ; The line is open, TEA7092 is powered from the +5V and the incoming message is sent from the answering machine to TEA7092 through the Pin LSIN (Pin 5) and amplified in TEA7092 loudspeaker amplifier to be heard in the loudspeaker.

When TEA7092 is powered with +5V on Pin V<sub>LS</sub> (Pin 1), the maximum power on the loudspeaker is :

- On R<sub>LS</sub> = 25 $\Omega$  : 100mW
- On R<sub>LS</sub> = 32 $\Omega$  : 80mW
- On R<sub>LS</sub> = 50 $\Omega$  : 50mW

III - CALL PROGRESS MONITOR AND GROUP LISTENING MODES (continued)

III.7 - Ring Melody Control Mode

**Note :** For complementary information, see Section IV.3 - Serial bus interface.

In OFF-HOOK mode it is possible to control the ring melody using the loudspeaker.

The ring melody is audible only in the loudspeaker.

This feature is enabled by the serial code : 0 1 1 0 0 1 1.

Figure 55 : Flow Chart

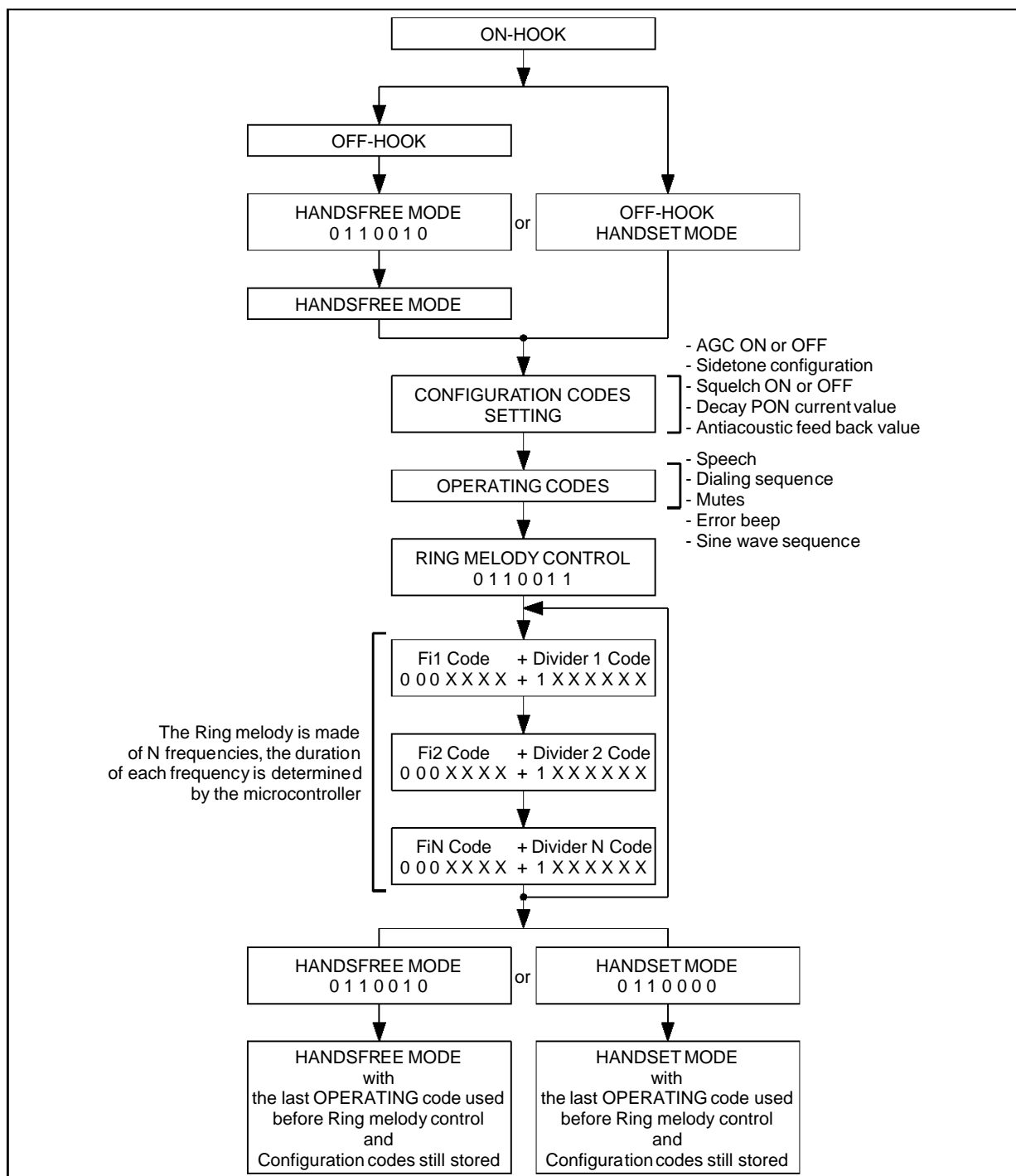

AN848-56.EPS

III - CALL PROGRESS MONITOR AND GROUP LISTENING MODES (continued)

III.8 - Beep Error Generator

**Note :** For complementary information, see Section IV.3 - Serial bus interface.

In OFF-HOOK mode it is possible to send a square wave signal in the earphone and in the loudspeaker by using the ring frequency generator, all frequencies available in ring mode are available in Beep error mode.

This feature is enabled by the serial code : 0 0 1 1 1 0 0 , which sent the square wave in the earphone.

To send the beep error on the loudspeaker it is necessary to complete the previous sequence with the Group listening code : 0 1 1 0 0 1.

Figure 56 : Flow Chart

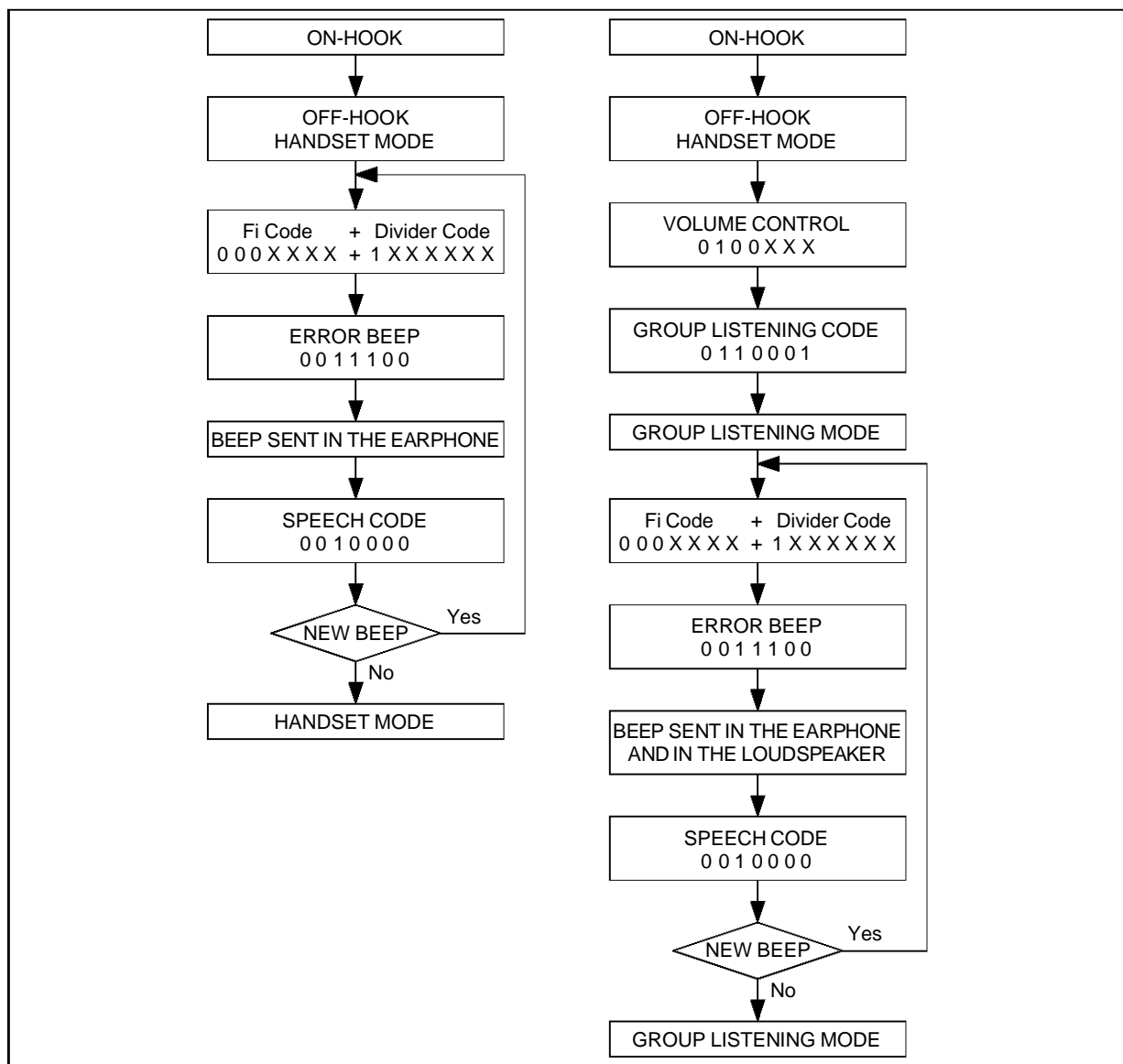

AN848-57-EP5

IV - MICROCONTROLLER INTERFACE

IV.1 - Microcontroller Power Supply

The microcontroller is used in every modes, speech, dialing and ring.

It is requested to start quickly in ring mode, less than 200ms and to maintain the supply on the microcontroller in pulse dialing mode, with a low voltage across the telephone set, or during an earth loop connection, in these two modes the microcontroller is supplied through the energy previously stocked in a capacitor and this capacitor should be able to maintain the power on the microcontroller during one second.

This compromise between the different modes is carried out through the microcontroller power management which is connected on Pin  $V_{MC}$  (Pin 2) and on Pin  $V_{RMC}$  (Pin 8).

Figure 57 shows the microcontroller power supply management.

In OFF-HOOK mode :

- C10 on Pin  $V_{MC}$  (Pin 2) is charged in priority with the  $I_{startup}$  ( $I_{LS}$ ) current source and is, after Reset high, powered with  $I_{VMC}$  (see Section II.1.3 - START UP CHARACTERISTICS).
- The voltage on Pin  $V_{MC}$  (Pin 2) is equal to :  $V_L$  (Pin 3) - 0.4V
- In Pulse dialing mode the microcontroller connected on the 3.5V regulated voltage, Pin  $V_{RMC}$  (Pin 8), is powered through the serial regulator.

In Ring mode :

- For the microcontroller power supply only the

capacitor C15 of 4.7 $\mu$ F connected on Pin  $V_{RMC}$  (Pin 8) has to be charged, so the start-up time in ring mode can be less than 200ms.

IV.2 - Reset and Pon Signals

These two pieces of information give the status of the Pin  $V_{RMC}$  (Pin 8) and of the line current,  $I_L$ .

In OFF-HOOK mode :

- Pin RESET (Pin 11) goes at high level when  $V_{RMC}$  reaches 2.6V and then remains at high level until  $V_{RMC}$  reaches the decay threshold fixed at 2.5V, or the Reset code (0 0 1 0 1 1 1) is received through the serial bus interface when PON is at low level. If the Reset code has been previously sent Pin RESET (Pin 11) goes back to an high level, if  $V_{RMC}$  is higher than the rise threshold, on a rise edge of PON signal.

Note : when PON is at high level, the Reset code is inhibited.

- Pin PON (Pin 12) goes at high level when the voltage at Pin  $V_{RMC}$  (Pin 8) reaches 2.6V and the line current ( $I_L$ ) reaches the value of 12mA, and then remains at high level until the line current ( $I_L$ ) goes below the threshold level fixed through the configuration code sent on the serial bus interface.
  - Decay threshold level :  $I_L = 12mA$  by default configuration.
  - Decay threshold level :  $I_L = 4mA$  if the code (0 1 1 1 0 0 1) is sent.

Figure 57

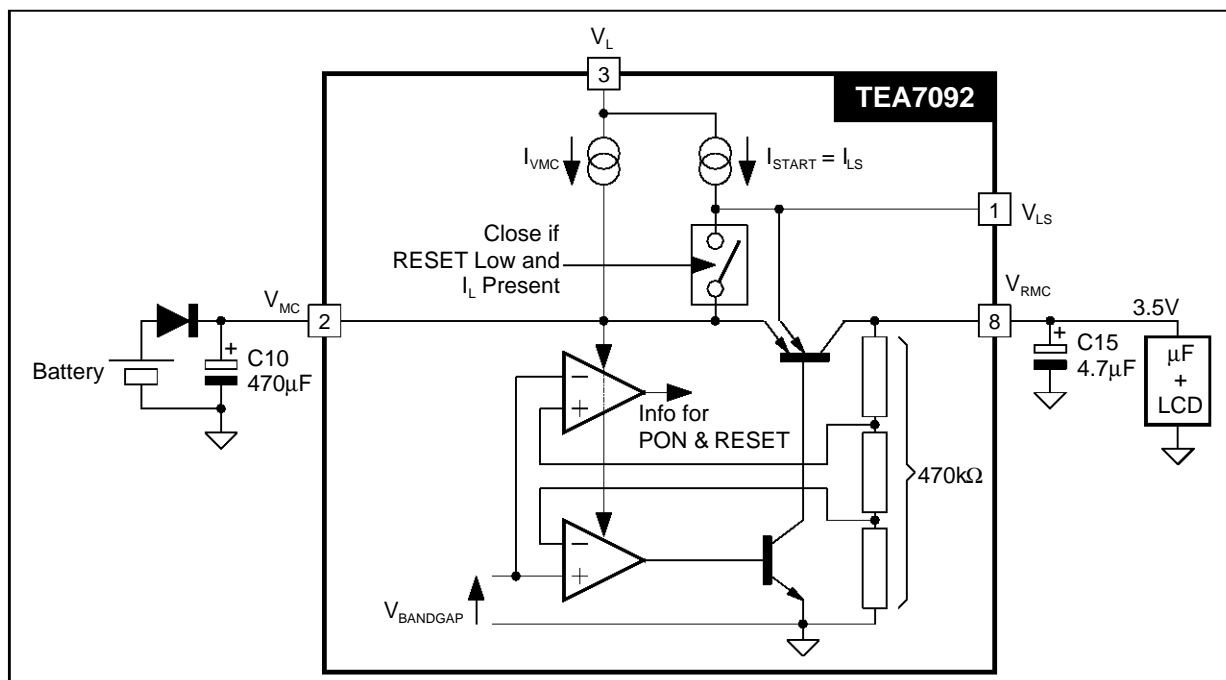

AN848-58.EPS

## IV - MICROCONTROLLER INTERFACE (continued)

### IV.2 - Reset And Pon Signals (continued)

Figure 58 shows the RESET and PON signals in different modes.

Different modes :

- A : ON-HOOK mode RESET and PON stay at low level
- B : START UP, as soon as the voltage on  $V_{RMC}$  reaches the rising threshold and the line current,  $I_L$  is higher than 12mA, RESET and PON go at high level.
- C : PULSE DIALING, PON follows the line current,  $I_L$  and RESET stays at high level.
- D : SPEECH or DTMF, RESET and PON stay at high level
- E : LINE BREAK EXCHANGE duration less than  $t_d$ , as soon as the line current,  $I_L$ , goes lower than the programmed threshold level (12 or 4mA), the PON signal goes to low level, the microcontroller detects it and starts an internal counter, if the feeding break is less than a prefixed  $t_d$  value (200ms for example), PON goes back to high level with the line current,  $I_L$  and the feeding break

is ignored by the kit TEA7092 and microcontroller.

- F : LINE BREAK EXCHANGE duration more than  $t_d$ , as soon as the line current,  $I_L$ , goes lower than the programmed threshold level (12 or 4mA), the PON signal goes to low level, the microcontroller detects it and starts an internal counter, if the feeding break is more than a prefixed  $t_d$  value (200ms for example), when the counter reaches 200ms is sent the Reset code (0 0 1 0 1 1 1) to the TEA7092 and the pin RESET (Pin 11) goes to low level, on this signal the microcontroller goes in reset condition.

In RING mode :

- Pin RESET (Pin 11) goes at high level when the voltage at Pin  $V_{RMC}$  (Pin 8) reaches the rise threshold and then remains at high level until Pin  $V_{RMC}$  (Pin 8) reaches the decay threshold, when the ring input voltage disappears, the decay threshold.
- Pin PON (Pin 12) stays at low level.

Figure 58

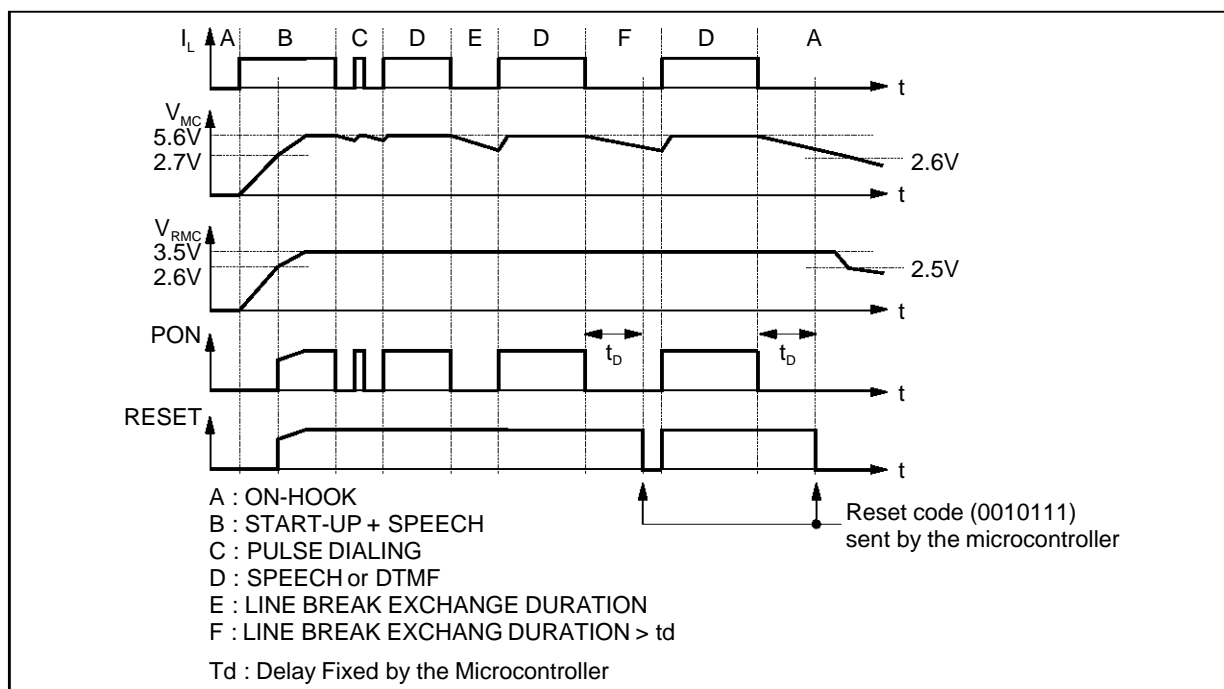

AN848-59 LEPS

IV - MICROCONTROLLER INTERFACE (continued)

IV.3 - Serial Bus Interface

Figure 59

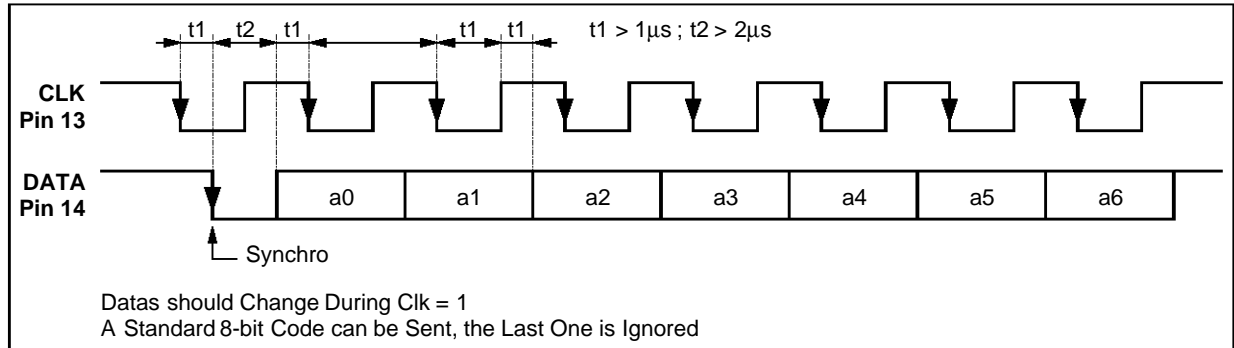

AN848-60/EPS

IV.3.1 - Different Codes

The serial bus interface works with 7 significant bits, a standard 8 bit code can be used, TEA7092 only takes care of the seven first bits. Figure 59 shows the timing of the Pin CLK (Pin 19) and of the Pin DATA (Pin 20).

TEA7092 Initialization

After Pin RESET (Pin 11) goes high, TEA7092 is initialized, the internal default programmed codes are given in **Bold** in the following code tables.

Codes programming TEA7092 are :

- The **MODE** codes :

The mode codes are the upper level of codes.

Codes							Remarks
a6	a5	a4	a3	a2	a1	a0	
0	1	1	0	0	0	0	<b>Handset Mode</b>
0	1	1	0	0	0	1	Group Listening Mode
0	1	1	0	0	1	0	Handsfree Mode

- The **OPERATING** codes which are related to the **MODE** codes :

Each operating code can be used under each mode code. When an operating code is sent, the previous one is cancelled.

Codes							Remarks
a6	a5	a4	a3	a2	a1	a0	
0	0	1	0	0	0	0	<b>Speech</b>
0	0	1	0	0	0	1	Dialing
0	0	1	0	0	1	0	Mute in Transmit and Receive Paths
0	0	1	0	0	1	1	Mute in Transmit Path
0	0	1	1	1	0	0	Error Beep
0	0	1	1	1	0	1	Sine wave High Frequency Group
0	0	1	1	1	1	0	Sine wave Low Frequency Group

# TEA7092 - TELEPHONE SET INTEGRATED CIRCUIT

## IV - MICROCONTROLLER INTERFACE (continued)

### IV.3.1 - Different Codes (continued)

- The **FLIP-FLOP** codes, each time they are sent, TEA7092 returns to the previous configuration.

Each Flip-Flop code is an independent one, its configuration is not modified by any other code, excepted the "Initialization" code and the "Reset" code.

These codes are accessible through the telephone set user, for example : The +6dB mode on the earphone which increases the earphone level is accessible through a dedicated key of the telephone set keyboard.

Codes							Remarks
a6	a5	a4	a3	a2	a1	a0	
0	0	1	0	1	0	1	<b>V<sub>L</sub>(3) DC Speech /</b> V <sub>L</sub> (3) DC Pulse Dialing
0	0	1	0	1	1	0	<b>Normal Receive Gain /</b> +6dB Receive Gain
0	0	1	1	0	1	0	<b>No Transfer /</b> Transfer Request
0	1	1	0	1	1	0	<b>Normal Transmit Gain /</b> -6dB Transmit Gain
0	1	1	1	0	1	0	<b>Oscillator ON /</b> Oscillator in Stand by Mode

- The **CONFIGURATION** codes, which are generally sent once to program a telephone set at each OFF-HOOK action, such as PABX connection or PON threshold level for example. are not accessible through the telephone set user. Excepted the Antiacoustic feedback stage attenuator value and the Decay PON current threshold, each code is an independant one, its configuration is not modified by any other code, except for the "Initialization" code and the "Reset" code.

Except for the Antiacoustic feedback stage attenuator programmation codes and the Decay PON current threshold, all the other Configuration codes are Flip-Flop codes.

Codes							Remarks
a6	a5	a4	a3	a2	a1	a0	
0	0	1	0	1	0	0	<b>AGC on Tx &amp; Rx Paths /</b> No AGC on Tx & Rx Paths
0	0	1	1	0	0	0	<b>Line Tracking Sidetone Network /</b> Single Sidetone Network = 3/4 x ZALL + 1/4 x ZASL
0	0	1	1	0	1	1	<b>Line Tracking Sidetone Network /</b> Single Sidetone Network = ZASL
0	0	1	1	0	0	1	<b>Squelch Feature ON /</b> Squelch Feature Inhibited
0	1	1	1	0	0	0	<b>Decay PON Current Threshold = 12mA</b>
0	1	1	1	0	0	1	Decay PON Current Threshold = 4mA
0	1	1	1	1	0	0	Antiacoustic Feedback Stage Attenuator = 10dB
0	1	1	1	1	0	1	<b>Antiacoustic Feedback Stage Attenuator = 15dB</b>
0	1	1	1	1	1	0	Antiacoustic Feedback Stage Attenuator = 20dB
0	1	1	1	1	1	1	Antiacoustic Feedback Stage Attenuator = 25dB

- The **LOUDSPEAKER VOLUME CONTROL** codes. These codes are memorized, independtly from the mode or operating code. For example one of these codes can be sent in Handset mode and when the Group listening mode code is sent, the loudspeaker output volume will be the one programmed in the Handset mode.

Codes							Remarks
a6	a5	a4	a3	a2	a1	a0	
0	1	0	0	1	1	1	Gmax
0	1	0	0	1	1	0	Gmax - 4dB
0	1	0	0	1	0	1	Gmax - 8dB
0	1	0	0	1	0	0	Gmax - 12dB
0	1	0	0	0	1	1	Gmax - 16dB
0	1	0	0	0	1	0	Gmax - 20dB
0	1	0	0	0	0	1	Gmax - 24dB
0	1	0	0	0	0	0	<b>Gmax - 28dB</b>
0	1	1	1	0	1	1	-21dB Attenuation Adder In Ring Mode*

\* Flip-Flop code.

**IV - MICROCONTROLLER INTERFACE** (continued)

**IV.3.1 - Different Codes** (continued)

- **HFIN input selection**

For answering machine or cordless connection, it can be requested to select HFIN (Pin 22) input, without enabling the loudspeaker, for this the following procedure should be sent :

- Handsfree code : 0 1 1 0 0 1 0
- Tx & Rx mutes : 0 0 1 0 0 1 0
- HFIN input select : 0 1 1 0 1 1 1

To go back to handsfree mode, send :

- Speech mode : 0 0 1 0 0 0 0

Or to go back to handset mode, send :

- Speech mode : 0 0 1 0 0 0 0
- Handset code : 0 1 1 0 0 0 0

- The **DTMF** and **SINE WAVE** codes.

These codes are memorized, independently from the mode or operating code. For example one of these code can be sent in Handset mode and when the Dialing mode code is sent, the DTMF frequencies sent on the line are those previously programmed in the Handset mode.

Codes							Key in DTMF Dialing	DTMF Dialing (Code 0010001 sent before)	SINE WAVE (Code 0011101 or 0011110 sent before)
a6	a5	a4	a3	a2	a1	a0			
0	0	0	0	0	0	0	"2"	697Hz + 1336Hz	
0	0	0	0	0	0	1	"1"	<b>697Hz + 1209Hz</b>	<b>348Hz or 604Hz</b>
0	0	0	0	0	1	0	"A"	697Hz + 1633Hz	
0	0	0	0	0	1	1	"3"	697Hz + 1477Hz	
0	0	0	0	1	0	0	"8"	852Hz + 1336Hz	
0	0	0	0	1	0	1	"7"	852Hz + 1209Hz	
0	0	0	0	1	1	0	"C"	852Hz + 1633Hz	
0	0	0	0	1	1	1	"9"	852Hz + 1477Hz	426Hz or 738Hz
0	0	0	1	0	0	0	"5"	770Hz + 1336Hz	385Hz or 668Hz
0	0	0	1	0	0	1	"4"	770Hz + 1209Hz	
0	0	0	1	0	1	0	"B"	770Hz + 1633Hz	
0	0	0	1	0	1	1	"6"	770Hz + 1477Hz	
0	0	0	1	1	0	0	"0"	941Hz + 1336Hz	
0	0	0	1	1	0	1	"*"	941Hz + 1209Hz	
0	0	0	1	1	1	0	"D"	941Hz + 1633Hz	470Hz or 816Hz
0	0	0	1	1	1	1	"#"	941Hz + 1477Hz	

- The Other Codes

Codes							Remarks
a6	a5	a4	a3	a2	a1	a0	
0	0	1	0	0	0	1	Ring Start
0	0	1	0	1	1	1	Reset Control (High to Low level on Pin 11 (RESET)), Internal TEA7092 Initialization and Microprocessor Serial Bus Connection Inhibited
0	1	1	0	0	1	1	Ring Melody Control, to listen the Ring Melody in the Loudspeaker During OFF-HOOK Mode.
0	1	0	1	0	0	0	TEA7092 Initialization (to go back to internal default programming)

## TEA7092 - TELEPHONE SET INTEGRATED CIRCUIT

### IV - MICROCONTROLLER INTERFACE (continued)

#### IV.3.1 - Different Codes (continued)

- The **RING** and **ERROR BEEP FREQUENCY** codes

Ring Frequencies (Hz) (see Note)		Fi Codes (Hz)			
Divider Codes	n	26321 (000XX10)	23551 (000XX11)	21308 (000XX00)	19455 (000XX01)
1010000	16	1645.0	1471.9	1331.7	1215.9
1010001	17	1548.3	1385.3	1253.4	1144.4
1010010	18	1462.3	1308.4	1183.8	1080.8
1010011	19	1385.3	1239.5	1121.5	1023.9
1010100	20	1316.0	1177.5	1065.4	972.7
1010101	21	1253.4	1121.5	1014.7	926.4
1010110	22	1196.4	1070.5	968.5	884.3
1010111	23	1144.4	1024.0	926.4	845.9
1011000	24	1096.7	981.3	887.8	810.6
1011001	25	1052.8	942.0	852.3	778.2
1011010	26	1012.3	905.8	819.5	748.3
1011011	27	974.8	872.3	789.2	720.6
1011100	28	940.0	841.1	761.0	<b>694.8</b>
1011101	29	907.6	812.1	734.8	670.9
1011110	30	<b>877.4</b>	<b>785.0</b>	710.3	648.5
1011111	31	849.1	759.7	687.3	627.6
1100000	32	822.5	<b>736.0</b>	665.9	608.0
1100001	33	797.6	713.7	645.7	589.5
1100010	34	774.1	692.7	626.7	572.2
1100011	35	752.0	672.9	608.8	<b>555.9</b>
1100100	36	731.1	654.2	591.9	540.4
1100101	37	711.4	636.5	575.9	525.8
1100110	38	692.7	<b>619.8</b>	560.7	512.0
1100111	39	674.9	603.9	546.4	498.8
1101000	40	<b>658.0</b>	<b>588.8</b>	532.7	486.4
1101001	41	642.0	574.4	519.7	474.5
1101010	42	626.7	560.7	507.3	463.2
1101011	43	612.1	547.7	<b>495.5</b>	452.4
1101100	44	598.2	535.2	484.3	442.2
1101101	45	584.9	<b>523.4</b>	473.5	432.3
1101110	46	572.2	512.0	<b>463.2</b>	422.9
1101111	47	560.0	501.1	453.4	<b>413.9</b>
1110000	48	548.3	490.6	443.9	405.3
1110001	49	537.2	480.6	434.9	397.0
1110010	50	526.4	471.0	426.2	389.1
1110011	51	516.1	461.8	417.8	381.5
1110100	52	506.2	452.9	409.8	374.1
1110101	53	496.6	444.4	402.0	367.1
1110110	54	487.4	436.1	394.6	360.3
1110111	55	478.6	428.2	387.4	353.7
1111000	56	470.0	420.5	380.5	347.4
1111001	57	461.8	413.2	373.8	341.3
1111010	58	453.8	406.0	<b>367.4</b>	335.4
1111011	59	446.1	399.2	361.1	<b>329.7</b>
1111100	60	<b>438.7</b>	<b>392.5</b>	355.1	324.2
1111101	61	431.5	386.1	<b>349.3</b>	318.9
1111110	62	424.5	379.8	343.7	313.8
1111111	63	417.8	373.8	338.2	308.8

These codes are memorized, independently from the mode or operating code. For example one of these code can be sent in Handset mode and when the Error Beep code is sent, the square wave frequency sent on the earphone is the one previously programmed in the Handset mode.

**Note :** It is possible to program n from 1 to 15, 1.0.0.0.0.0.0 to 1.0.0.1.1.1.1, the frequency values are not given in the previous table, but can be calculated in the same way.

IV - MICROCONTROLLER INTERFACE (continued)

IV.3.2 - Software Example

Sequence : ON-HOOK ; OFF-HOOK ; AGC OFF ; HANDSET ; DTMF dialing ; GROUP LISTENING ; ERROR BEEP ; +6dB on earphone ; Normal gain on earphone ; ON-HOOK.

Figure 60 : Flow Chart

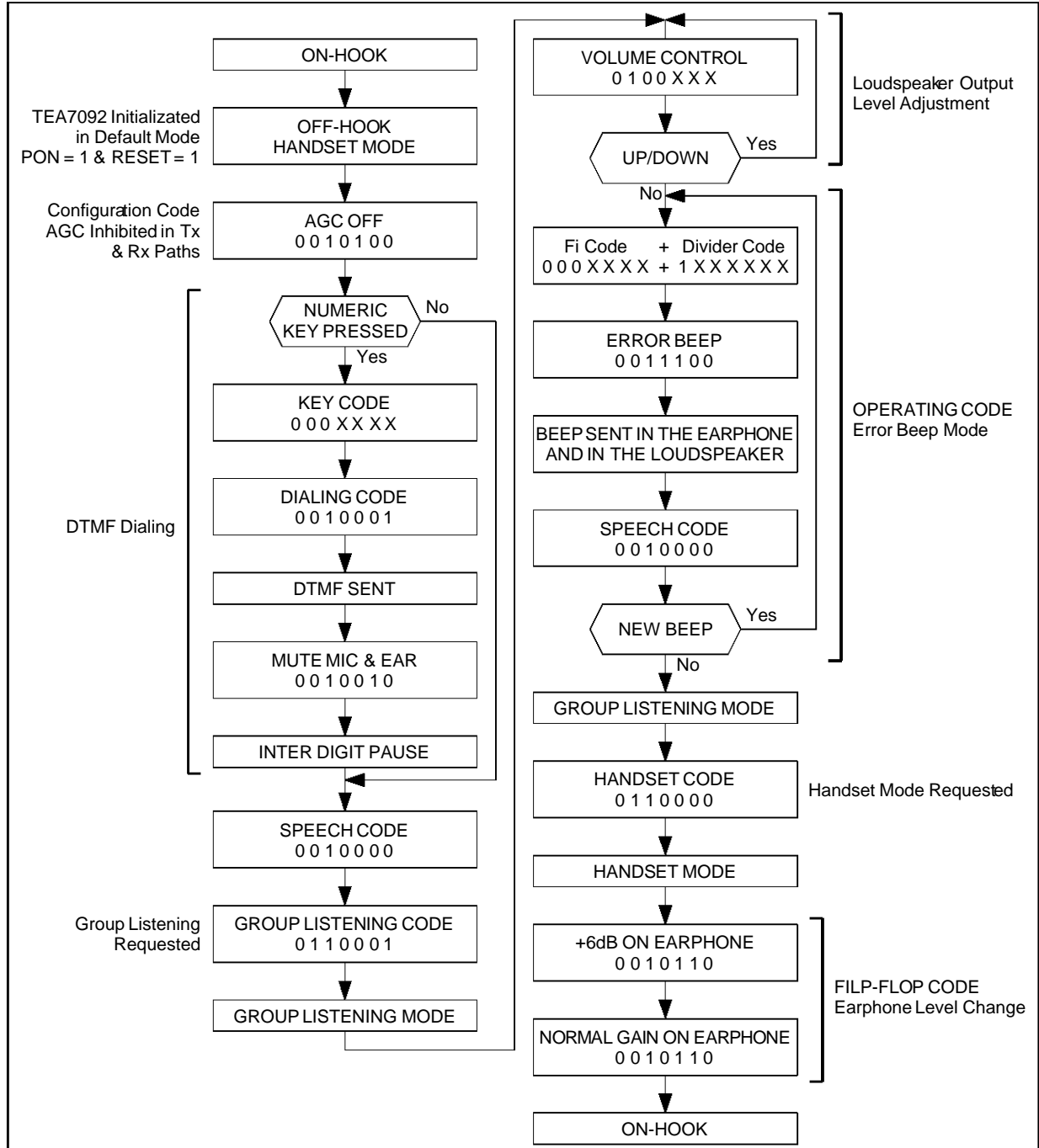

AN848-61.EPS

# TEA7092 - TELEPHONE SET INTEGRATED CIRCUIT

## IV - MICROCONTROLLER INTERFACE (continued)

### IV.3.3 - Serial Bus Code Actions on Switches

Figure 61, Tables below give the switch positions and the generator status for the different serial codes sent on the serial bus interface.

Figure 61

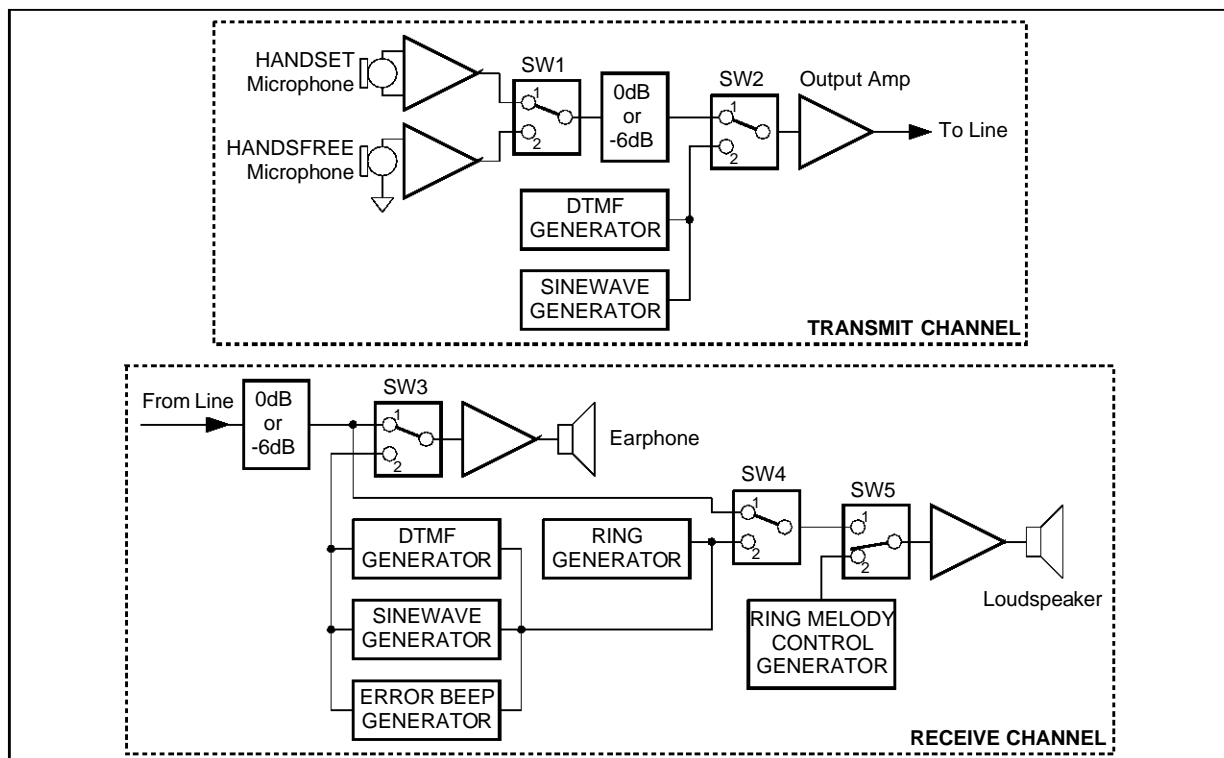

AN848-62.EPS

The mode codes, Handset, Group listening act only on switches SW1 and SW5.

Codes	Switches					Generators			
	SW1	SW2	SW3	SW4	SW5	DTMF	Sinewave	Error beep	Ring Melody Control
Default	1				2	Disabled	Disabled	Disabled	Disabled
Handset Mode	1	1			2				Disabled
Group Listening Mode	1	1			1				Disabled
Handsfree Mode	2	1	2	1	1				Disabled
Ring melody control	1	2	2	1	2				Enabled

The Operating codes act only on switches SW2, SW3 and SW4, the positions on the switches SW1 and SW5 are the ones previously determined by the Mode codes.

**Note :** In Ring Melody Control, the operating codes are not accessible.

Operating Codes		Switches			Generators		
		SW2	SW3	SW4	DTMF	Sinewave	Error Beep
Speech	0010000	1	1/2*	1	Disabled	Disabled	Disabled
Dialing	0010001	2	2	2	Enabled	Disabled	Disabled
Mute in Tx & Rx	0010010	2	2	2	Disabled	Disabled	Disabled
Mute in Tx	0010011	2	1/2*	1	Disabled	Disabled	Disabled
Error Beep	0011100	1	2	2	Disabled	Disabled	Enabled
Sinewave HF Group	0011101	2	2	2	Disabled	Enabled	Disabled
Sinewave LF Group	0011110	2	2	2	Disabled	Enabled	Disabled

\* 1 for Handset and Group listening modes, 2 for Handsfree mode.

**IV - MICROCONTROLLER INTERFACE** (continued)

**IV.4 - Ring Indicator - Line Current Variation Indicator**

The Pin RI/VI (Pin 10) is used for different modes :

- In Ring mode, when the threshold level, programmed on Pin RSU (Pin 40), is reached and the Pin RESET (Pin 11) is high, the Pin RI/VI (Pin 10) goes to high logic level.
- In OFF-HOOK mode the pin RI/VI (Pin 10) gives an indication of the line current variation when the transfer feature is requested.

The transfer feature happens when there are two telephone sets connected in parallel on the same line and the user wants to transfer the communication from telephone "1" to telephone "2" and ON-HOOK telephone "1".

With TEA7092 in telephone "1".

Telephone "1" is in speech mode, the user presses the "Transfer" key on telephone "1". When the "Transfer" key is pressed, the microcontroller sends the Transfert code (0 0 1 1 0 1 0) and TEA7092 memorizes the line current value. The user ON-HOOK telephone "1", the line is maintained closed by the microcontroller, through the pulse dialing high voltage stage.

When the user OFF-HOOK telephone "2", the line current value in telephone "1" decreases, TEA7092 detects this line current variation and the Pin RI/VI goes to high logic level. When the microcontroller receives this signal it puts off the high voltage stage of telephone "1".

Telephone "1" goes in OFF-HOOK mode.

Figure 62 gives the value of the line current variation ( $\Delta I_L$ ) which generates a high logic level on Pin RI/VI (Pin 10).

**IV.5 - Oscillator**

The Oscillator is powered on Pin  $V_{RMC}$  (Pin 8). The oscillator is only used for DTMF, sine wave, beep error, ring frequency generator and transfer feature.

In Pulse dialing flash or earth button, it is preferable to reduce, the current consumption on

Pin  $V_{RMC}$  (Pin 8) as low as possible, in order to have the lowest possible value of capacitor on Pin  $V_{MC}$  (Pin 2).

The toggle code (0 1 1 1 0 1 0) puts the Oscillator in stand by mode or not.

The current consumption on Pin  $V_{RMC}$  (Pin 8) is :

- Oscillator ON : 250 $\mu$ A
- Oscillator OFF : 50 $\mu$ A

The default condition is Oscillator ON.

If the microcontroller has a 3.58MHz resonator, the oscillator output of the microcontroller can be connected, through a capacitor, to the Pin OSC (Pin 9) so as to provide TEA7092 with the 3.58MHz signal.

**IV.6 - Microcontroller Signal Control in the Different Modes**

The following table lists the configuration of the signals given by TEA7092 in the different modes :

Signals/Modes	Reset	PON	RI/VI
ON-HOOK	0	0	0
OFF-HOOK	1	1	0
RING	1	0	1
Line Current Variation Detected in Transfer Mode	1	1	1
External Supply Only	1	0	0

**Figure 62 : Current Line Variation to Detect Transfer**

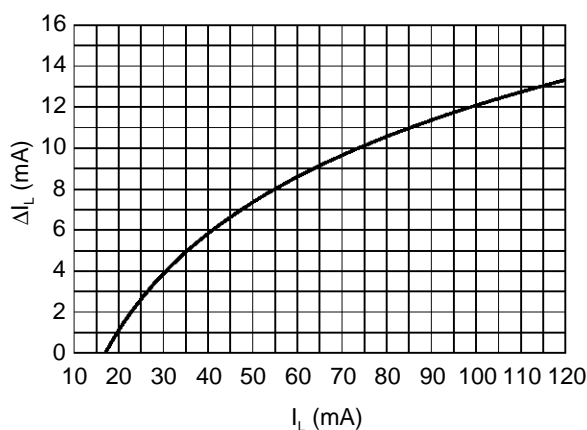

AN848-63LEPS

V - DIALER FEATURES

V.1 - DTMF Dialer

Figure 63

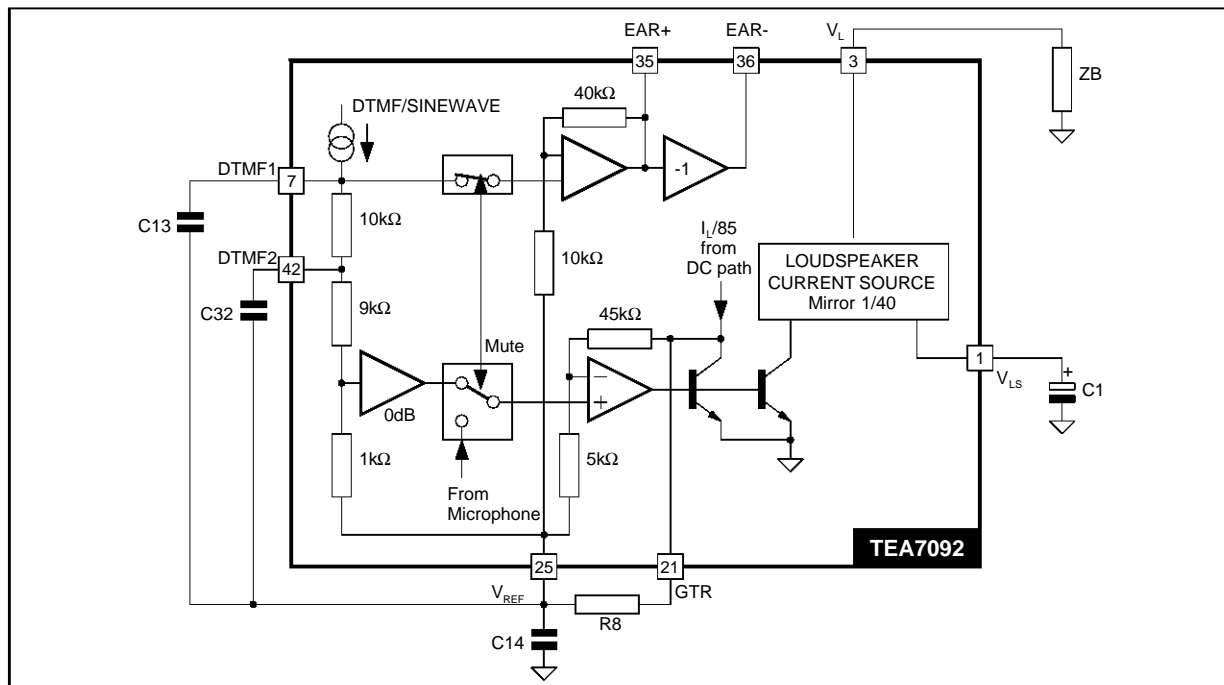

AN848-64.EPS

The DTMF dialer generates the frequencies in order to drive a telephone set keyboard and complies with the recommendation Q.23 of the CCITT-T/CS 46-02.

It generates :

- The low frequency group (697, 770, 852, 941Hz)
- The high frequency group (1209, 1336, 1477, 1633Hz)

Figure 63 shows the DTMF amplifier path.

The MUTE signal driven through the serial bus, selects the microphone signal or the DTMF signal and the confidence tone level for the earphone and the loudspeaker.

The DTMF level is fixed by C13 on Pin DTMF1 (Pin 7) and by R8 on Pin GTR (Pin 21), C32 on Pin DTMF2 (Pin 42) fixes the cut off frequency of the second filter.

- Cut-off frequency on DTMF1 :

$$f_1 = \frac{1}{2 \cdot \pi \cdot 20 \cdot 10^3 \cdot C13} \text{ with } C13 = 47\text{nF}, f_1 = 170\text{Hz}.$$

An internal twist between each DTMF frequency is programmed so as to take care to follow the T/CS46-02 recommended levels.

- Cut-off frequency on DTMF2 :

$$f_2 = \frac{1}{2 \cdot \pi \cdot 10 \cdot 10^3 \cdot C32} \text{ with } C32 = 2.7\text{nF}, f_2 = 5.9\text{kHz}.$$

Figure 64 shows the DTMF signaling.

Figure 64

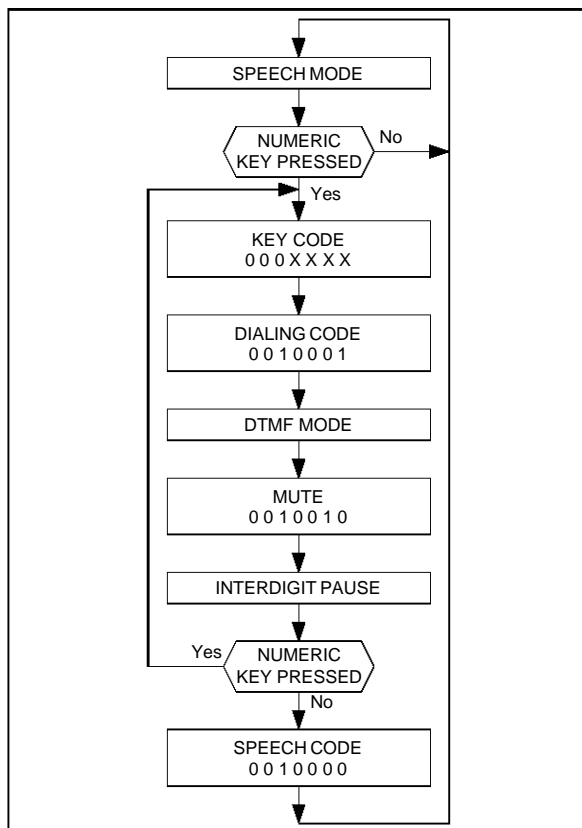

AN848-65.EPS

V - DIALER FEATURES (continued)

V.2 - Sinewave Generator

The Sinewave generator is programmable like the DTMF generator. This one generates the DTMF frequencies divided by 2, in single tone mode in two groups :

- CodeDTMF + code 0011101: 348, 385, 426, 470Hz
- CodeDTMF + code 0011110: 604, 668, 738, 816Hz

The sinewave level on line is 8dB lower than the DTMF dialing level.

This sinewave generator can be used in mute mode to send on line a signal to advise the other party than you are in Secret mode.

V.3 - Pulse Dialer Interface

In pulse dialing mode, if the code (0 0 1 0 1 0 1) is

used, the voltage across TEA7092 is reduced to 2V on Pin  $V_L$  (Pin 3), this way it is possible to achieve a low voltage across the telephone set during the make period of the pulse dialing sequence.

Figure 65 shows the DC voltage across TEA7092 and across the telephone set in pulse dialing mode.

**Note :** It is possible to generate an acoustic control in the earphone in pulse dialing mode with the code (0010101). This code should be sent twice within the break period of the pulse dialing. For example, if the break period is 60ms, send the code (0010101) 10ms after the start of the break period and send it again 10ms before the end of the break period. This will generate a DC level change in the earphone which will be audible.

Figure 65 : Mask / No Mask Mode

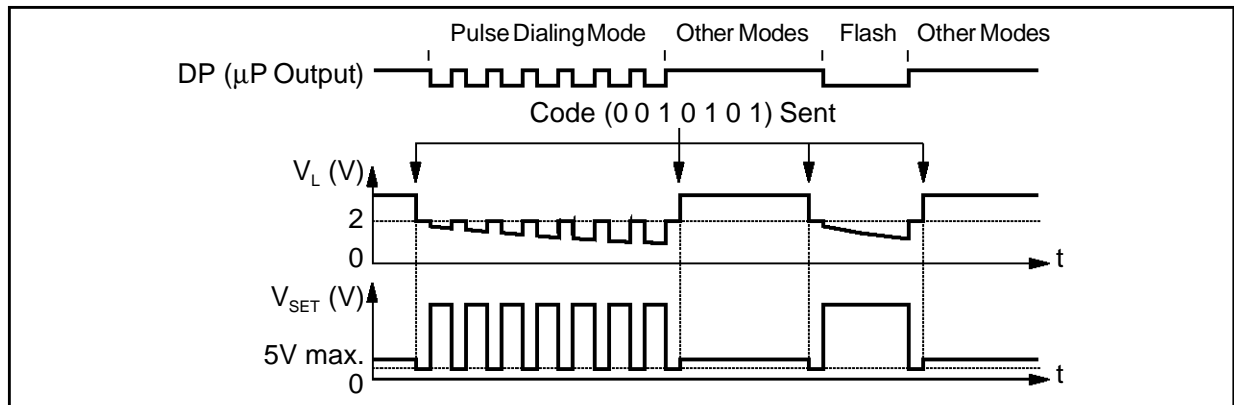

AN848-66.EPS

# TEA7092 - TELEPHONE SET INTEGRATED CIRCUIT

## VI - RINGER FEATURES

### VI.1 - Ringer Power Supply

In ring mode only the ring part, the loudspeaker amplifier, the logic part and the microcontroller supply are powered. The supply is provided by a switch mode power supply.

Figure 66 shows the ring part.

The switch mode power supply converts the high ac ring line voltage, 30 to 90V<sub>RMS</sub> at 25 or 50Hz, into a low DC voltage, 3 to 5.6V, which is used to supply the loudspeaker amplifier and the microcontroller. The switch mode power supply made by T1, T2, L1, D7 and the resistors associated, is driven through the Pin SWP (Pin 39).

The control on SWP is done by a 26kHz oscillator. The coil L1 is 1mH, the diode D7 is a 1N4148.

### VI.2 - Start-Up Threshold Level

By default, the ring threshold level is internally set up at 18.8VDC on Pin RSU (Pin 40) :  $(3 \times 5.6V + V_{BE} (0.6V) + 2 \times V_{THN} (2 \times 0.7V))$ , equivalent to an AC ring level of 13.3V<sub>RMS</sub>.

As soon as this threshold level is reached, a 11.2V hysteresis is introduced to assure the system's stability

The V<sub>RING1</sub> start up level is set up on Pin RSU (Pin 40) with R35 and if necessary a zener diode D5 added in serial with R35, most of the countries don't request D5.

V<sub>RING1</sub> : Start up level.

$$V_{RING1} = 18.8 + \left( \frac{R35}{300k\Omega} \cdot 0.7 \right) + V_Z(D5) \text{ in V}$$

**Note** : Recommended value for R35 is 56kΩ.

Figure 66

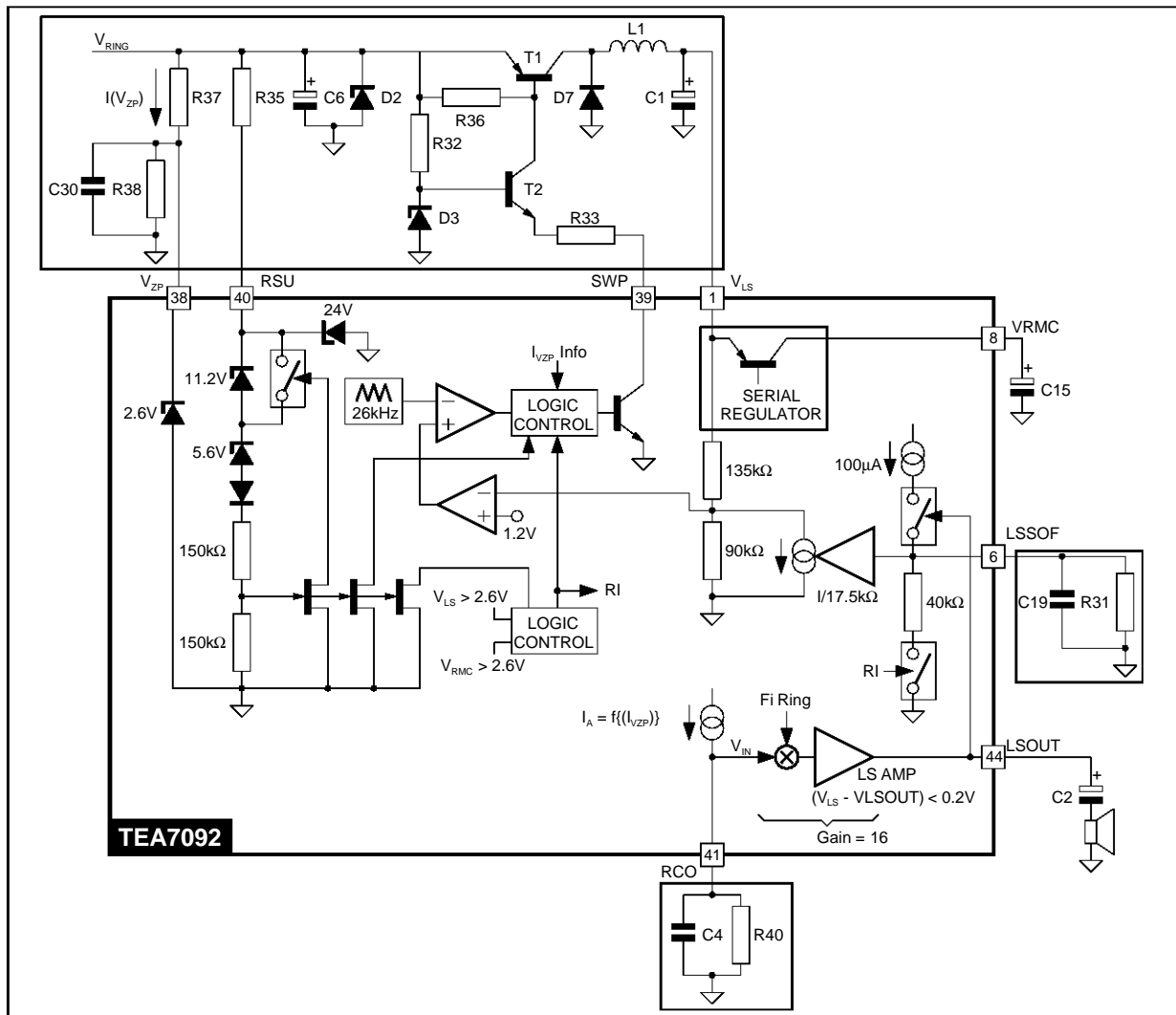

**VI - RINGER FEATURES** (continued)

**VI.3 - Ring Frequency Generator**

The ring frequency values which can be generated are those given Page 45 of this application note.

On the Table given at Page 45, only the frequency values for  $n > 15$  are given, the frequency values from  $n = 1$  (1000000) to  $n = 15$  (1001111) are also accessible, if it is necessary to generate a frequency higher than 1645Hz.

**VI.4 - Output Power Optimization**

The power available on Pin LSOUT (Pin 44) depends on :

- The country requires :
  - Minimum input ac level in test conditions.
  - Ring impedance.
 Taking in account these main requests the power on Pin LSOUT (Pin 44) is optimized through the resistor R40 connected on Pin RCO (Pin 41).
- The yield of the switch mode power supply.
 The principal parameters which influence the yield are :
  - D7  $V_{BE}$  value.
  - T1  $V_{CEsat}$  and base current values (the maximum  $I_{C PEAK}$  value is 100mA).
  - L1 serial resistor value.
  - Current consumption on Pin  $V_{ZP}$  (Pin 38) and on Pin RSU (Pin 40).
  - Bias current consumption on Pin  $V_{LS}$

This paragraph gives information on :

- The switch mode power supply concept.
- The switch mode power supply yield.
- The ring output power optimization on Pin LSOUT (Pin 44).

**VI.4.1 - Switch Mode Power Supply Concept**

After the ring bridge, the switch mode power supply concept is represented in Figure 67.

$V_E$	Input voltage equivalent to $V_{RING1}$
$V_{E1}$	Input voltage after the switch SW1
$I_E$	Mean input current
$V_S$	Output voltage at Pin $V_{LS}$ (Pin 1)
$I_S$	Mean output current
$V_D$	Voltage across D7 when it is in forward mode
$I_{E0}$	Primary bias current
$I_{S0}$	Secondary bias current
RL1	Resistive part of the coil L1
Switch SW1	- $V_{CEsat}$ of T1 PNP - $I_{B1}$ , T1 base current - $t_D$ , T1 desaturation time - $V_{E1} = V_E - V_{CEsat}(T1)$

Figure 68 gives the voltage,  $V_{E1}$ , the current in the coil,  $I_{SELF}$ , the current in D7,  $I_{DIODE}$  and the current in the switch SW1 given by C6,  $I_{CAPA}$ .

The value of the maximum current in the coil is fixed by  $t_{ON}$  and  $t_{OFF}$  depends on RL. When RL decreases,  $t_{ON}$  increases. The coil value should be calculated so that the current in the coil reaches the zero value with the minimum charge.

$$I_{Max.} = t_{ON} \cdot \frac{V_{E1} - V_{LS}}{L} \quad (1)$$

L is the value of the coil L1.

The ratio between  $t_{ON}$  and  $t_{OFF}$  is :

$$\frac{t_{ON}}{t_{OFF}} = \frac{V_D + V_{LS}}{V_{E1} - V_{LS}} \quad (2)$$

The output current  $I_S$  is :

$$I_S = \frac{I_{Max.}}{2} \cdot \frac{t_{ON} + t_{OFF}}{t} \quad (3)$$

**Figure 67**

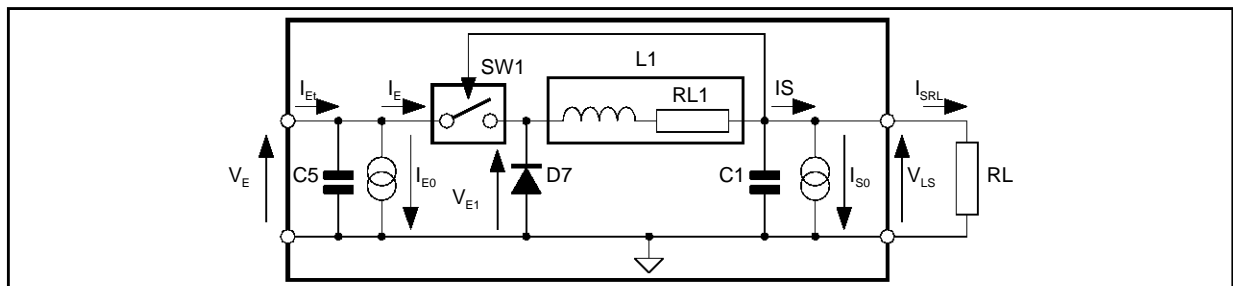

VI - RINGER FEATURES (continued)

VI.4 - Output Power Optimization (continued)

Figure 68

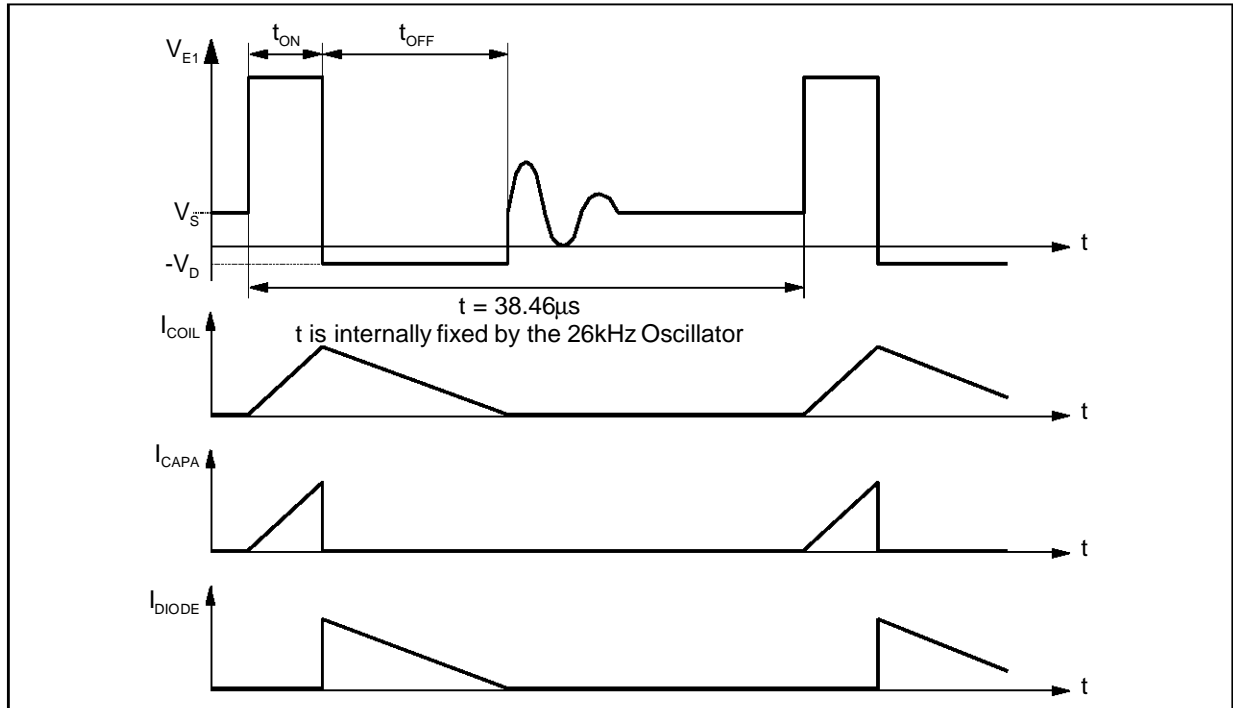

AN848-68EPS

VI.4.2 - Switch Mode Power Supply Losses

The sum of all the different losses gives the yield of the switch mode power supply.

The final yield is :

$$\eta_{\text{final}} = \frac{\text{POUT}}{\text{POUT} + \sum \text{Pi}}$$

where : Pi are the different losses, POUT is the power in the load RL :  $\text{POUT} = 4 \times \text{RL} \times (\text{ISRL})^2$ .

The output current Is is :  $\text{Is} = \text{ISRL} + \text{IS0}$ .

Using the equations (1), (2) and (3), the values of tON and tOFF can be found :

$$\frac{t_{\text{ON}}}{t} = \sqrt{2 \cdot L \cdot f \cdot \text{Is} \cdot \frac{\text{VLS} + \text{VD}}{(\text{VE1} - \text{VLS}) \cdot (\text{VE1} + \text{VD})}} \quad f = 26\text{kHz}$$

$$\frac{t_{\text{OFF}}}{t} = \sqrt{2 \cdot L \cdot f \cdot \text{Is} \cdot \frac{\text{VE1} - \text{VLS}}{(\text{VLS} + \text{VD}) \cdot (\text{VE1} + \text{VD})}}$$

$$\text{I}_{\text{Max}} = \sqrt{\frac{2}{L \cdot f} \cdot \text{Is} \cdot \frac{(\text{VE1} - \text{VLS}) \cdot (\text{VLS} + \text{VD})}{\text{VE1} + \text{VD}}}$$

**VI - RINGER FEATURES** (continued)

**VI.4 - Output Power Optimization** (continued)

The different losses are :

- In the switch SW1 :

$$P_{VCEsat} = \frac{I_{Max.} \cdot t_{ON}}{2 \cdot t} \cdot V_{CEsat}$$

$$= I_S \cdot V_{CEsat} \cdot \frac{V_{LS} + V_D}{V_{E1} + V_D}$$

• T1 base current (IBT1) :

$$P_{IBT1} = V_E \cdot I_{BT1} \cdot \frac{t_{ON}}{t}$$

$$= V_E \cdot I_{BT1} \cdot \sqrt{\frac{2 \cdot L \cdot f \cdot (V_{LS} + V_D)}{(V_{E1} - V_{LS}) \cdot (V_{E1} + V_D)}}$$

• tD, desaturation time of T1 :

$$P_{desat} = V_E \cdot \frac{I_{Max.} \cdot t_D}{25 \cdot t}$$

$$\Rightarrow = V_E \cdot t_D \cdot \sqrt{\frac{2 \cdot f \cdot I_S \cdot (V_{E1} - V_{LS}) \cdot (V_{LS} + V_D)}{L \cdot (V_{E1} + V_D)}}$$

• T2 base current (IBT2) :  $P_{IBT2} = \frac{(V_E - 8.2)^2}{R32}$

- In the diode D7 :

$$P_{DIODE} = \frac{I_{Max.} \cdot t_{OFF}}{2 \cdot t} \cdot V_D$$

$$\Rightarrow = I_S \cdot V_D \cdot \frac{V_{E1} - V_S}{V_{E1} + V_D}$$

- At the primary ; The sum of these losses is equal to :  $V_E \times I_{E0}$

• On Pin VZP (Pin 38) :  $V_{ZP} (\text{Pin 38}) = 2.55V$  ;

$$P_{VZP} = \frac{(V_E - 2.55)^2}{R34 + R37}$$

• On Pin RSU (Pin 40) :

$$P_{RSU} = \frac{(V_E - 5.6)}{R35 + 300k\Omega} \cdot V_E$$

- In the coil :

$$P_{coil} = R_{coil} \cdot \left( \frac{I_{Max.}}{2} \right)^2 \cdot \frac{t_{ON}^2 + t_{OFF}^2}{t^2}$$

$$\Rightarrow = R_{coil} \cdot I_S^2 \cdot \frac{(V_{E1} - V_{LS})^2 + (V_{LS} + V_D)^2}{(V_{E1} + V_D)^2}$$

- At the secondary ; The sum of these losses is equal to :  $V_{LS} \times I_{S0}$

• Current consumption of all the part powered on Pin VLS (Pin 1) :  $P_{VLS} = V_{LS} \times I_{PLS}$ .

• Current consumption of the microcontroller :  $P_{\mu P} = V_{LS} \times I_{\mu P}$  ;  $I_{S0} = I_{PLS} + I_{\mu P}$ .

•  $V_{CEsat}$  of the loudspeaker amplifier output stage :  $POLS = 0.2 \times I_{SRL}$

- The sum of the losses is :

$$P_{TOTAL} = \Sigma P_i$$

$$= P_{VCEsat} + P_{IBT1} + P_{desat} + P_{IBT2} + P_{VZP} + P_{RSU} + P_{coil} + P_{VLS} + P_{\mu P} + P_{OLS} + P_{diode}$$

**VI.4.3 - Output Power Adjustment**

The optimization of the output power depends on the system environment. It is therefore necessary to know the power which can be given by the system in the best and worst loop line. Each country has a different loop line system.

Figure 69 shows the system configuration.

**Figure 69**

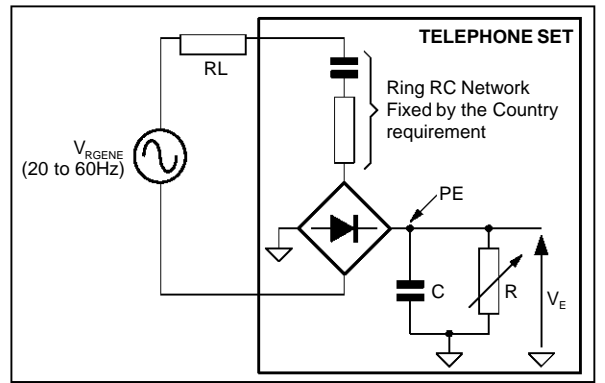

The minimum power available, PE1 is for :  $V_{RGENE}(\text{Min.})$  and  $RL(\text{Max.})$ .

The maximum power available, PE2 is for :  $V_{RGENE}(\text{Max.})$  and  $RL(\text{Min.})$ .

Figure 70 gives the power available at the input of the switch mode power supply.

**Figure 70**

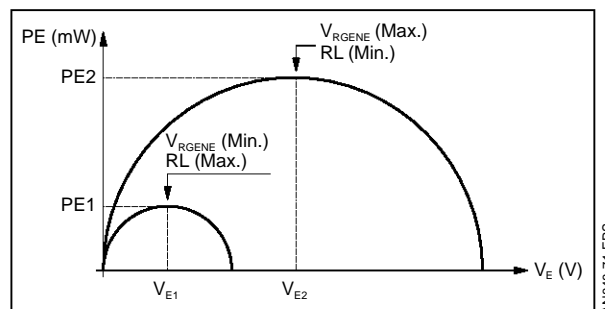

The output signal on Pin LSOUT (Pin 44) is controlled through the current information given on Pin VZP (Pin 38) (see Figure 66).

**VI - RINGER FEATURES** (continued)

**VI.4 - Output Power Optimization** (continued)

The principle is :

- From the current  $I(V_{ZP})$  in the resistor R37, a current  $I_A$  is issued and equal to :

$$I_A = \frac{I(V_{ZP}) - 39\mu A - \frac{2.6}{R38}}{9} \quad (1)$$

The  $39\mu A$  current is the bias current of the internal 2.6V zener connected on Pin  $V_{ZP}$  (Pin 38).

$$I(V_{ZP}) = \frac{V_{RING} - 2.6}{R37} \quad (2)$$

- The current  $I_A$  generates a voltage on Pin RCO (Pin 41) equal to :  
 $V(RCO) = R40 \times I_A \quad (3)$

- This input voltage, mixed with the ring frequency is amplified to the loudspeaker connected on pin LSOUT (Pin 44), and the peak to peak square output voltage  $V_{PP}(LSOUT)$  is :

$$V_{PP}(LSOUT) = 16 \times V(RCO) \quad (4)$$

(1), (2), (3) & (4)

⇒

$$V_{PP}(LSOUT) = \frac{16}{9} \cdot R40 \cdot \left( \frac{V_{RING}}{R37} - 39\mu A - \frac{2.6}{R35/R38} \right)$$

When the  $V_{RING}$  input voltage is high enough to saturate the output stage on Pin LSOUT (Pin 44), compared to Pin  $V_{LS}$  (Pin 1), ( $V_{LS}$  (Pin 1) -  $V_{PP}$  (LSOUT) < 0.2V), the switch in serial with the current source on Pin LSSOF (Pin 6) is activated, and the input voltage on Pin LSSOF (Pin 6) is converted in current, with a  $1/17.5k\Omega$  transconductance. Finally this current increases the voltage on Pin  $V_{LS}$  (Pin 1) and allows the output voltage,  $V_{PP}(LSOUT)$  on Pin LSOUT (Pin 44) to increase.

At low  $V_{RING}$  input voltage, Pin  $V_{LS}$  (Pin 1) is clamped at a 3V minimum voltage, to maintain a proper supply to the microcontroller on Pin  $V_{RMC}$  (Pin 8), and the output voltage on Pin LSOUT (Pin 44) is progressively reduced.

When the  $V_{RING}$  input voltage increases, the Pin  $V_{LS}$  (Pin 1) increases up to 6V and is clamped to 6V by an internal zener.

The Figure 71 gives the voltage on Pin  $V_{LS}$  (Pin 1), on Pin RCO (Pin 41) and the  $V_{PP}(LSOUT)$  on Pin LSOUT (Pin 44) versus the  $V_{RING}$  input voltage with : R37 = 200k $\Omega$ , R38 = 150k $\Omega$ , R40 = 47k $\Omega$

The values of R37, R38 and R40 should be calculate to adapt the output power requested on Pin LSOUT (Pin 44) to the available power, during ring mode, on the terminal wire as described on Figures 69 and 70 of this application note.

The recommended values for a ring network of,  $C_{RING} = 1\mu F$ ,  $R_{RING} = 1.5k\Omega$  are :

- R37 = 200k $\Omega$ , R38 = 150k $\Omega$
- P40 = 47k $\Omega$ ,  
 if  $f_{RING} = 25$  or 50Hz /  $R_{LOUDSPEAKER} = 50\Omega$
- R40 = 39k $\Omega$ , if  $f_{RING} = 50$ Hz /  $R_{LOUDSPEAKER} = 32\Omega$
- R40 = 33k $\Omega$ , if  $f_{RING} = 25$ Hz /  $R_{LOUDSPEAKER} = 32\Omega$

**VI.5 - Microcontroller Management (RI / RESET)**

In ring mode, two pieces of information are given to control the microcontroller :

- Pin RESET (Pin 11) which goes at level "1" if Pin  $V_{RMC}$  (Pin 8) > 2.6V.
- Pin RI/VI (Pin 10) which goes at level "1" if :
  - Pin RSU (Pin 40) > 19V
  - Pin  $V_{RMC}$  (Pin 8) > 2.6V
  - Current in Pin  $V_{ZP}$  (Pin 38) > 40 $\mu A$
- After a ring mode, Pin RI/VI (Pin 10) goes back to level "0", if Pin RSU (Pin 40) goes lower than 8V.

**Figure 71**

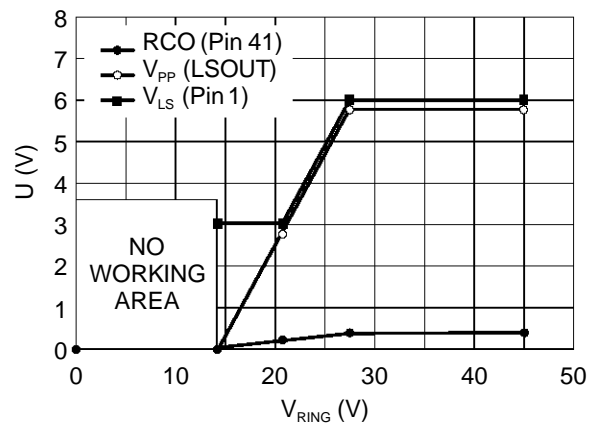

AN848-72.EPS

VI - RINGER FEATURES (continued)

VI.6 - Ring Software

To generate the ring on the loudspeaker, the flowchart is in Figure 72.

Figure 72

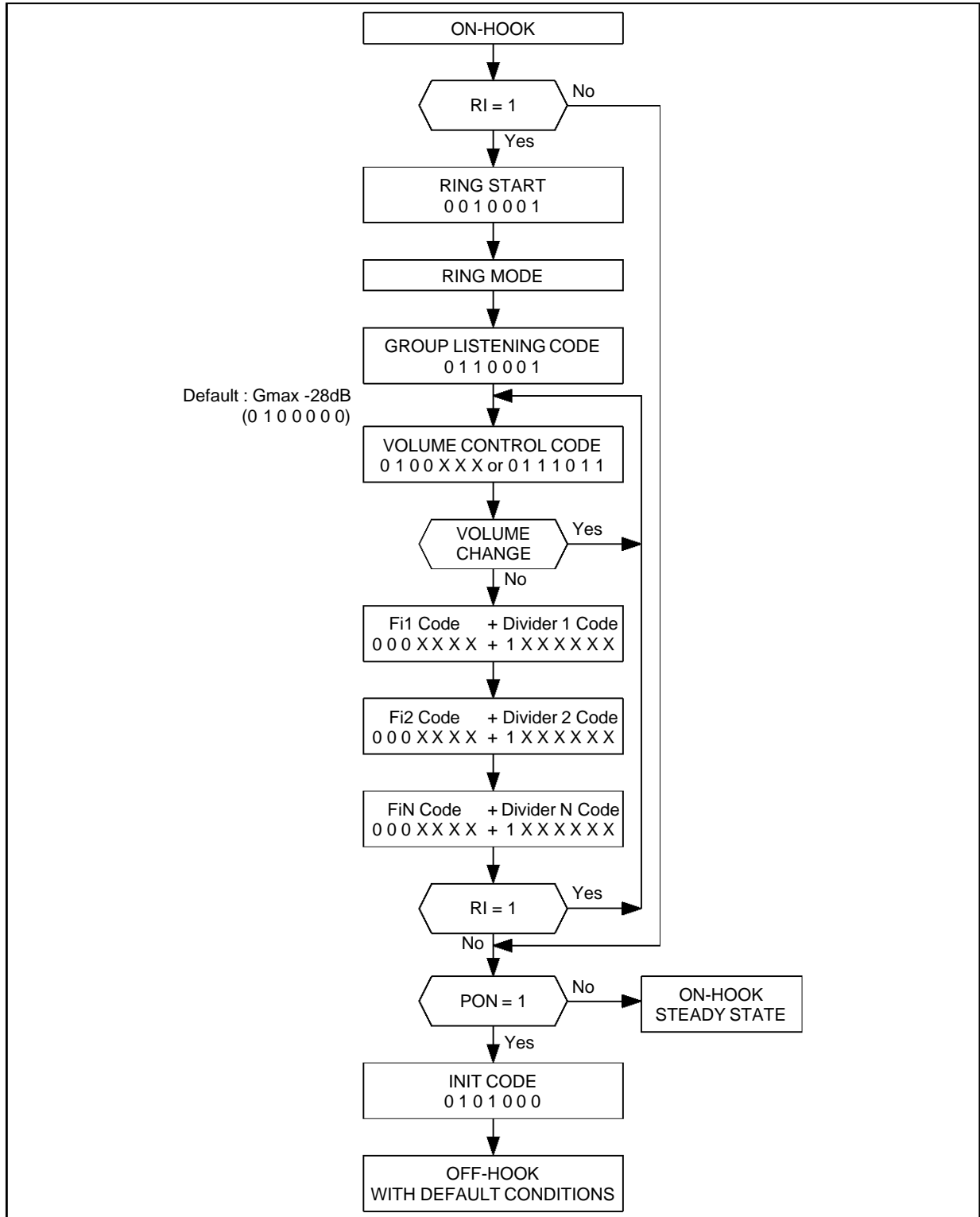

AN848-73.EPS

# TEA7092 - TELEPHONE SET INTEGRATED CIRCUIT

## VII - APPLICATION DIAGRAM

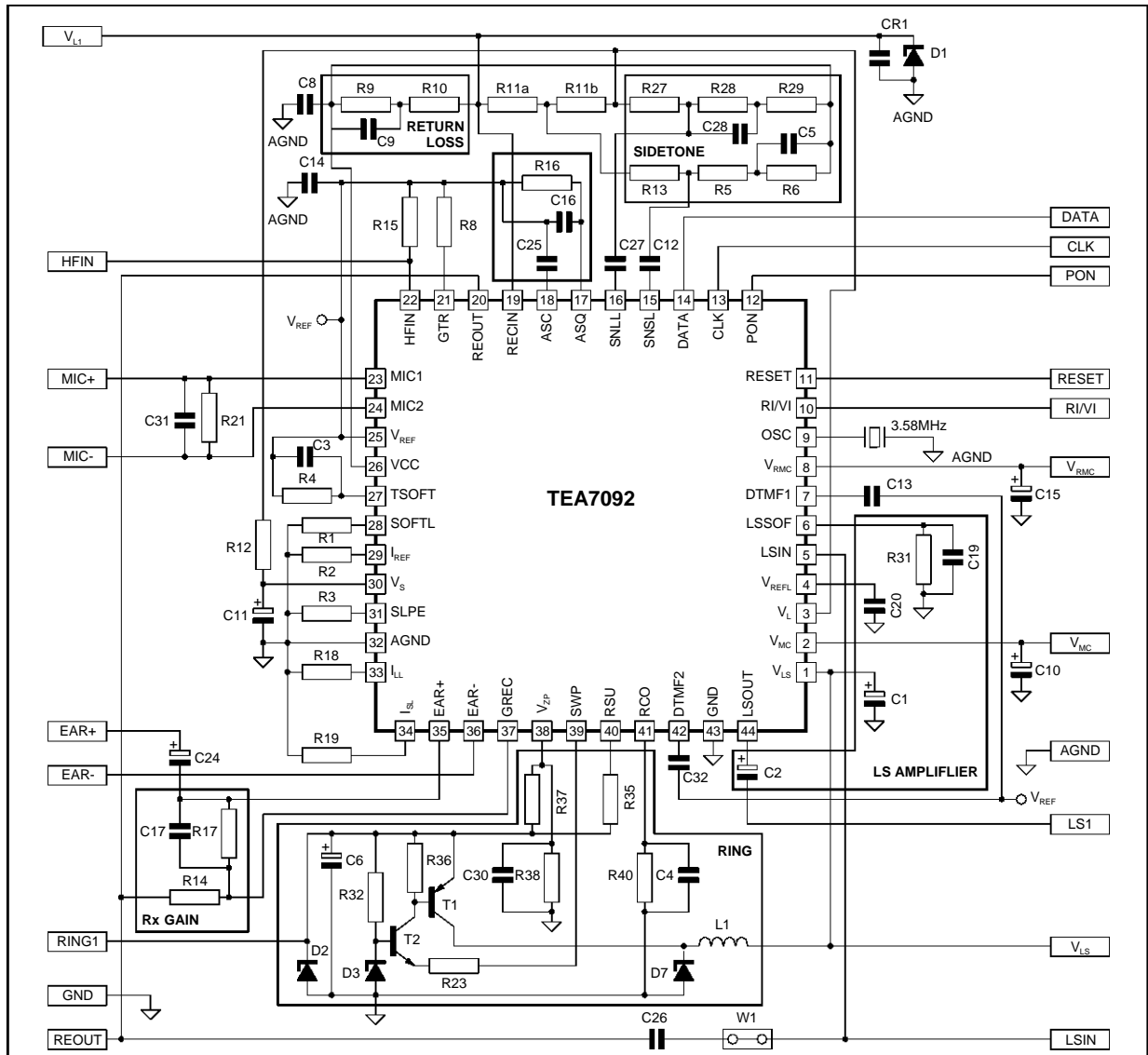

AN848-74.EPS

Ref.	Part	Ref.	Part	Ref.	Part	Ref.	Part	Ref.	Part
R1	56kΩ	R15	2.2kΩ	R36	4.7kΩ	L1	1mH	C14	47nF
R2	30kΩ	R16	330kΩ	R37	200kΩ	Q1	3,58MHz	C15	4.7μF
R3	2.7kΩ	R17	75kΩ	R38	150kΩ	C1	100μF	C16	1μF
R4	820kΩ	R18	18kΩ	R40	47kΩ (50Hz/50Ω)*	C2	47μF	C17	330pF
R5	0	R19	6.8kΩ		47kΩ (25Hz/50Ω)*	C3	150nF	C19	470nF
R6	39kΩ	R21	1.5kΩ		39kΩ (50Hz/32Ω)*	C4	220nF	C20	47nF
R8	1.62kΩ	R27	3.3kΩ		33kΩ (25Hz/32Ω)*	C5	560pF	C25	470nF
R10	680Ω	R28	33kΩ	D1	13V	C6	10μF (63V)	C26	47nF
R11a	24Ω	R29	18kΩ	D2	47V	C8	47μF	C27	100nF
R11b	6.2Ω	R31	560kΩ	D3	8.2V	C10	470μF	C28	1.8nF
R12	100kΩ	R32	220kΩ	D7	1N4148	C11	1μF	C30	1.2nF
R13	2.7kΩ	R33	1.5kΩ	T1	BC556B	C12	100nF	C31	10nF
R14	47kΩ	R35	56kΩ	T2	BC546B	C13	47nF	C32	2.7nF
								CR1	10nF

\* (Ring frequency / LS impedance)

Information furnished is believed to be accurate and reliable. However, SGS-THOMSON Microelectronics assumes no responsibility for the consequences of use of such information nor for any infringement of patents or other rights of third parties which may result from its use. No licence is granted by implication or otherwise under any patent or patent rights of SGS-THOMSON Microelectronics. Specifications mentioned in this publication are subject to change without notice. This publication supersedes and replaces all information previously supplied. SGS-THOMSON Microelectronics products are not authorized for use as critical components in life support devices or systems without express written approval of SGS-THOMSON Microelectronics.

© 1996 SGS-THOMSON Microelectronics - All Rights Reserved

Purchase of I<sup>2</sup>C Components of SGS-THOMSON Microelectronics, conveys a license under the Philips I<sup>2</sup>C Patent. Rights to use these components in a I<sup>2</sup>C system, is granted provided that the system conforms to the I<sup>2</sup>C Standard Specifications as defined by Philips.

SGS-THOMSON Microelectronics GROUP OF COMPANIES

Australia - Brazil - Canada - China - France - Germany - Hong Kong - Italy - Japan - Korea - Malaysia - Malta - Morocco  
The Netherlands - Singapore - Spain - Sweden - Switzerland - Taiwan - Thailand - United Kingdom - U.S.A.



LittleDiode supplies new, hard to find or obsolete electronic components and semiconductors all over the world.

With over two million different components listed you are sure to find the part you need.

Feel free to visit us today at our online store:

[LittleDiode.com](http://LittleDiode.com)

Looking forward to providing you with the best possible service.