

# AN8472SA

## Spindle motor driver IC for optical disk

### ■ Overview

The AN8472SA is a high performance IC suited for driving a spindle motor of an optical disk such as CD-ROM, DVD etc. Small outline package can be used due to reduced power consumption by adopting the direct PWM drive system.

### ■ Features

- 3-phase full-wave 120° duty factor system
- Low power consumption due to a direct PWM system
- D-MOS transistor with low ON resistance (0.6 Ω typ.) on the output stage
- With start and stop pins
- Thermal shut-down function built-in
- With FG output pin
- Reverse breaking by EC/ECR voltage
- With Hall bias pin
- Surface-mount small package

### ■ Applications

- Optical disk drive of CD-ROM, DVD-ROM, CD-R, CD-RW etc.

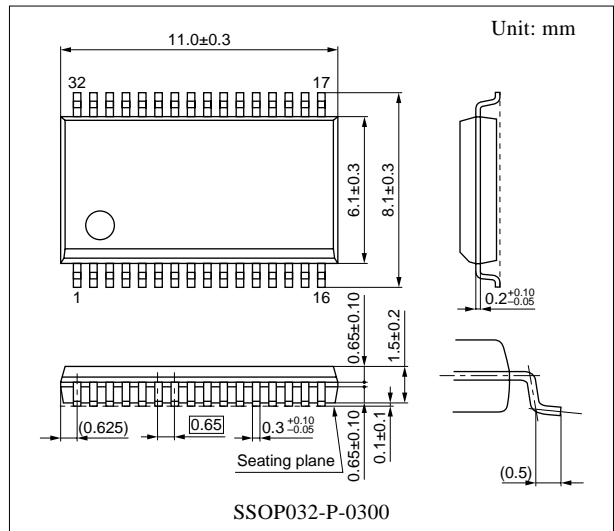

■ Block Diagram

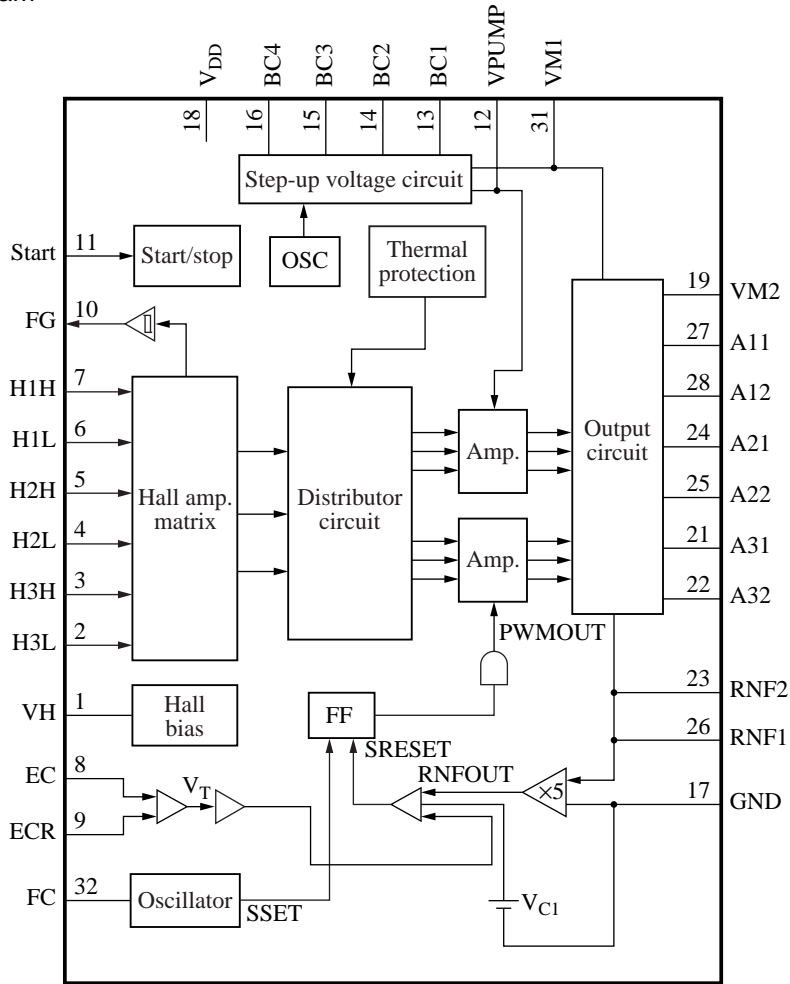

■ Pin Descriptions

Pin No.	Symbol	Description	Pin No.	Symbol	Description
1	VH	Hall bias pin	13	BC1	Booster capacitor connection pin 1
2	H3L	Hall element-3 negative input pin	14	BC2	Booster capacitor connection pin 2
3	H3H	Hall element-3 positive input pin	15	BC3	Booster capacitor connection pin 3
4	H2L	Hall element-2 negative input pin	16	BC4	Booster capacitor connection pin 4
5	H2H	Hall element-2 positive input pin	17	GND	Ground pin
6	H1L	Hall element-1 negative input pin	18	V <sub>DD</sub>	Supply voltage pin
7	H1H	Hall element-1 positive input pin	19	VM2	Motor supply voltage pin 2
8	EC	Torque command input pin	20	N.C.	N.C.
9	ECR	Torque command reference input pin	21	A31	Drive output 3
10	FG	FG signal output pin	22	A32	Drive output 3
11	Start	Start/stop changeover pin	23	RNF2	Current det. pin 2
12	VPUMP	Booster pin	24	A21	Drive output 2

### ■ Pin Descriptions (continued)

Pin No.	Symbol	Description	Pin No.	Symbol	Description
25	A22	Drive output 2	29	N.C.	N.C.
26	RNF1	Current det. pin 1	30	N.C.	N.C.
27	A11	Drive output 1	31	VM1	Motor supply voltage pin 1
28	A12	Drive output 1	32	FC	Oscillator pin

### ■ Absolute Maximum Ratings

Parameter	Symbol	Rating	Unit
Supply voltage *2	$V_{DD}$	6	V
	$V_{M1}$		
	$V_{M2}$		
Drive output voltage *5	$V_{(m)}$	15	V
Control signal input voltage *6	$V_{(n)}$	0 to $V_{DD}$	V
Supply current	$I_{DD}$	30	mA
Drive output current *4	$I_{(o)}$	$\pm 1$ 200	mA
Hall bias current *7	$I_{HB(n)}$	30	mA
Power dissipation *3	$P_D$	293	mW
Operating ambient temperature *1	$T_{opr}$	-20 to +70	°C
Storage temperature *1	$T_{stg}$	-55 to +150	°C

Note) Do not apply external currents or voltages to any pins not specifically mentioned.

For circuit currents, '+' denotes current flowing into the IC, and '-' denotes current flowing out of the IC.

\*1: Except for the operating ambient temperature and storage temperature, all ratings are for  $T_a = 25^\circ\text{C}$ .

\*2: The voltage in the step-up voltage circuit exceeds the supply voltage.

For the allowable value of the step-up voltage, refer to "■ Electrical Characteristics".

\*3: The power dissipation shown is the value of independent IC without a heat sink at  $T_a = 70^\circ\text{C}$ . Refer to the  $P_D - T_a$  curves of the "■ Application Notes" for details.

\*4: o = 19, 21, 22, 23, 24, 25, 26, 27, 28, 31

\*5: m = 21, 22, 24, 25, 27, 28

\*6: n = 8, 9, 11

\*7: n = 1, 2, 3, 4, 5, 6, 7

### ■ Recommended Operating Range

Parameter	Symbol	Range	Unit
Supply voltage	$V_{DD}$	4.5 to 5.5	V
	$V_{M1}$		
	$V_{M2}$		

**■ Electrical Characteristics at  $T_a = 25^\circ\text{C}$** 

Parameter	Symbol	Conditions	Min	Typ	Max	Unit
<b>Overall</b>						
Circuit current 1	$I_{DD1}$	$V_{DD} = 5\text{ V}$ in power save mode	—	0	0.1	mA
Circuit current 2	$I_{DD2}$	$V_{DD} = 5\text{ V}$	—	9	14	mA
<b>Start/stop</b>						
Start voltage	$V_{START}$	Voltage with which a circuit operates at $V_{DD} = 5\text{ V}$ and $L \rightarrow H$	2.7	—	—	V
Stop voltage	$V_{STOP}$	Voltage with which a circuit becomes off at $V_{DD} = 5\text{ V}$ and $H \rightarrow L$	—	—	0.7	V
<b>Hall bias</b>						
Hall bias voltage	$V_{HB}$	$V_{DD} = 5\text{ V}$ , $I_{HB} = 20\text{ mA}$	0.7	1.3	1.6	V
<b>Hall amplifier</b>						
Input bias current	$I_{BH}$	$V_{DD} = 5\text{ V}$	—	1	5	$\mu\text{A}$
In-phase input voltage range	$V_{HBR}$	$V_{DD} = 5\text{ V}$ , except for H2H, H2L	1.5	—	4.0	V
Minimum input level	$V_{INH}$	$V_{DD} = 5\text{ V}$	60	—	—	mV[p-p]
<b>Torque command</b>						
In-phase input voltage range	EC	$V_{DD} = 5\text{ V}$	0.5	—	3.9	V
Offset voltage	$EC_{OF}$	$V_{DD} = 5\text{ V}$	-100	0	100	mV
Dead zone	$EC_{DZ}$	$V_{DD} = 5\text{ V}$	0	75	150	mV
Input current	$EC_{IN}$	$V_{DD} = 5\text{ V}$ , $EC = ECR = 2.5\text{ V}$	-5	-1	—	$\mu\text{A}$
Input/output gain	$A_{CS}$	$V_{DD} = 5\text{ V}$ , $R_{CS} = 0.33\ \Omega$	0.36	0.48	0.60	A/V
<b>Output</b>						
High-level output saturation voltage	$V_{OH}$	$V_{DD} = 5\text{ V}$ , $I_O = -500\text{ mA}$	—	0.15	0.30	V
Low-level output saturation voltage	$V_{OL}$	$V_{DD} = 5\text{ V}$ , $I_O = 500\text{ mA}$	—	0.15	0.30	V
Torque limit current	$I_{TL}$	$V_{DD} = 5\text{ V}$ , $R_{CS} = 0.33\ \Omega$	455	570	685	mA
<b>OSC</b>						
Charging current	$I_{CH}$	$V_{DD} = 5\text{ V}$	-65	-50	-35	$\mu\text{A}$
Upper threshold voltage	$V_{CH}$	$V_{DD} = 5\text{ V}$	1.75	2.50	3.25	V
Lower threshold voltage	$V_{CL}$	$V_{DD} = 5\text{ V}$	0.35	0.50	0.65	V
<b>FG</b>						
FG output high-level	$FG_H$	$V_{DD} = 5\text{ V}$ , $I_{FG} = -0.01\text{ mA}$	3	—	—	V
FG output low-level	$FG_L$	$V_{DD} = 5\text{ V}$ , $I_{FG} = 0.01\text{ mA}$	—	—	0.5	V
In-phase input voltage range	$V_{FGR}$	$V_{DD} = 5\text{ V}$	1.5	—	3.0	V
FG hysteresis width	$H_{FG}$	$V_{DD} = 5\text{ V}$	5	10	20	mV
<b>Step-up circuit</b>						
Step-up voltage	$V_{PUMP}$	$V_{DD} = 5\text{ V}$ , $V_{M1} = V_{M2} = 5\text{ V}$	9.5	—	15	V

■ Electrical Characteristics at  $T_a = 25^\circ\text{C}$  (continued)

• Design reference data

Note) The characteristics listed below are theoretical values based on the IC design and are not guaranteed.

Parameter	Symbol	Conditions	Min	Typ	Max	Unit
Thermal protection						
Thermal protection operating temperature	$T_{SDON}$	$V_{DD} = 5\text{ V}$	—	155	—	$^\circ\text{C}$
Thermal protection hysteresis width	$\Delta T_{SD}$	$V_{DD} = 5\text{ V}$	—	45	—	$^\circ\text{C}$

■ Terminal Equivalent Circuits

Pin No.	Symbol	Equivalent circuit
1	VH	
2	H3L	
3	H3H	
4	H2L	
5	H2	
6	H1L	Refer to pin 2
7	H1H	
8	EC	
9	ECR	

### ■ Terminal Equivalent Circuits (continued)

Pin No.	Symbol	Equivalent circuit
10	FG	
11	Start	
12	VPUMP	
13	BC1	
14	BC2	
15	BC3	
16	BC4	
17	GND	Ground pin
18	V <sub>DD</sub>	Supply voltage pin
19	VM2	
20	N.C.	N.C.
21	A31	Refer to pin 19
22	A32	
23	RNF2	
24	A21	
25	A22	
26	RNF1	
27	A11	
28	A12	

■ Terminal Equivalent Circuits (continued)

Pin No.	Symbol	Equivalent circuit
29	N.C.	N.C.
30	N.C.	N.C.
31	VM1	Refer to pin 19
32	FC	

■ Usage Notes

- Prevent this IC from being line-to-ground fault.  
 (To be concrete, do not short-circuit any of A31 (pin 21), A32 (pin 22), A21 (pin 24), A22 (pin 25), A11 (pin 27) and A12 (pin 28) with GND pin (pin 17).)
- Precaution must be taken on the pin 13 and pin 16 due to approximately 200 V of the static breakdown voltages.  
 (C = 200 pF, R = 0 Ω)

■ Application Notes

- $P_D - T_a$  curves of SSOP032-P-0300

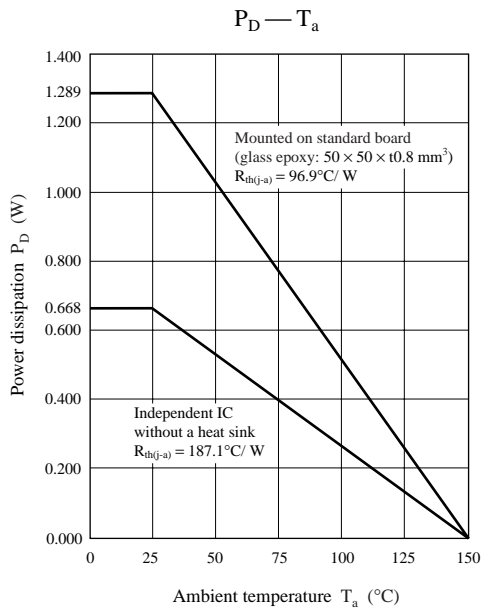

■ Application Notes (continued)

- Phase conditions between Hall input and output current

Phase of Hall pin			
	H1H	H2H	H3H
A	H	ML	ML
B	MH	L	MH
C	ML	ML	H
D	L	MH	MH
E	ML	H	ML
F	MH	MH	L

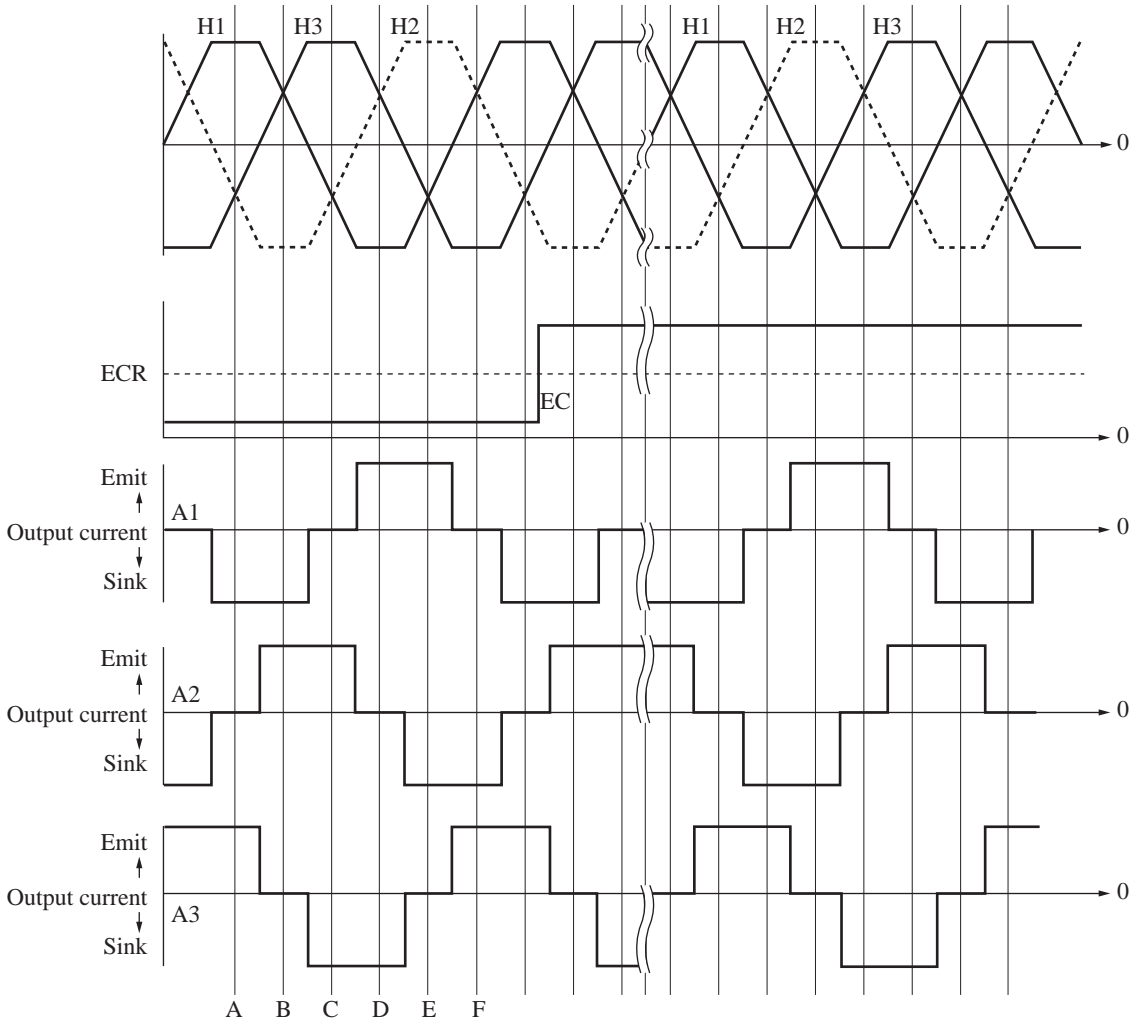

■ Application Circuit Example

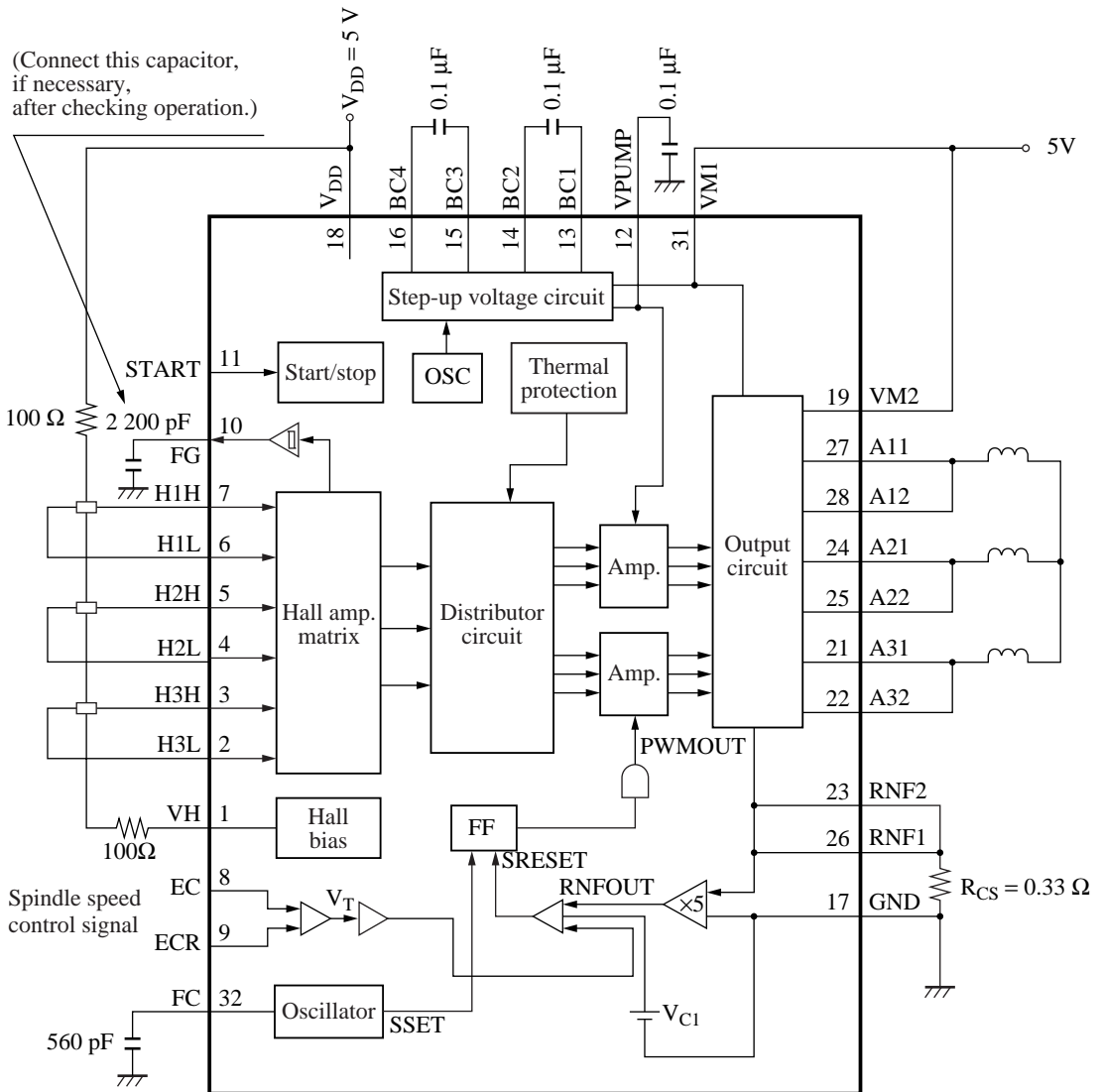



LittleDiode supplies new, hard to find or obsolete electronic components and semiconductors all over the world.

With over two million different components listed you are sure to find the part you need.

Feel free to visit us today at our online store:

[LittleDiode.com](http://LittleDiode.com)

Looking forward to providing you with the best possible service.