

AN8470NSA

Spindle motor driver IC for optical disk

Overview

The AN8470NSA is a high performance IC suited for driving a spindle motor of an optical disk such as CD-ROM, PD, DVD, CD-R, CD-RW, etc.

Features

- Low power consumption due to a direct PWM system
- With start and stop pin
- Reverse braking by EC/ECR voltage
- With Hall bias pin
- Surface-mount small package

Applications

- High speed CD-ROM drive
- PD, DVD, CD-R, CD-RW drives

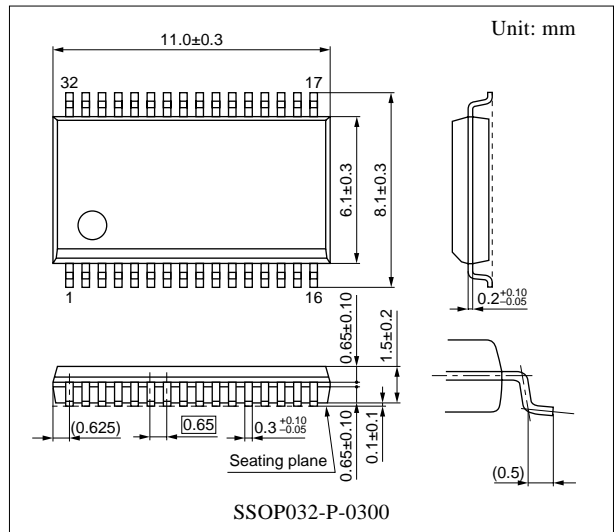

Block Diagram

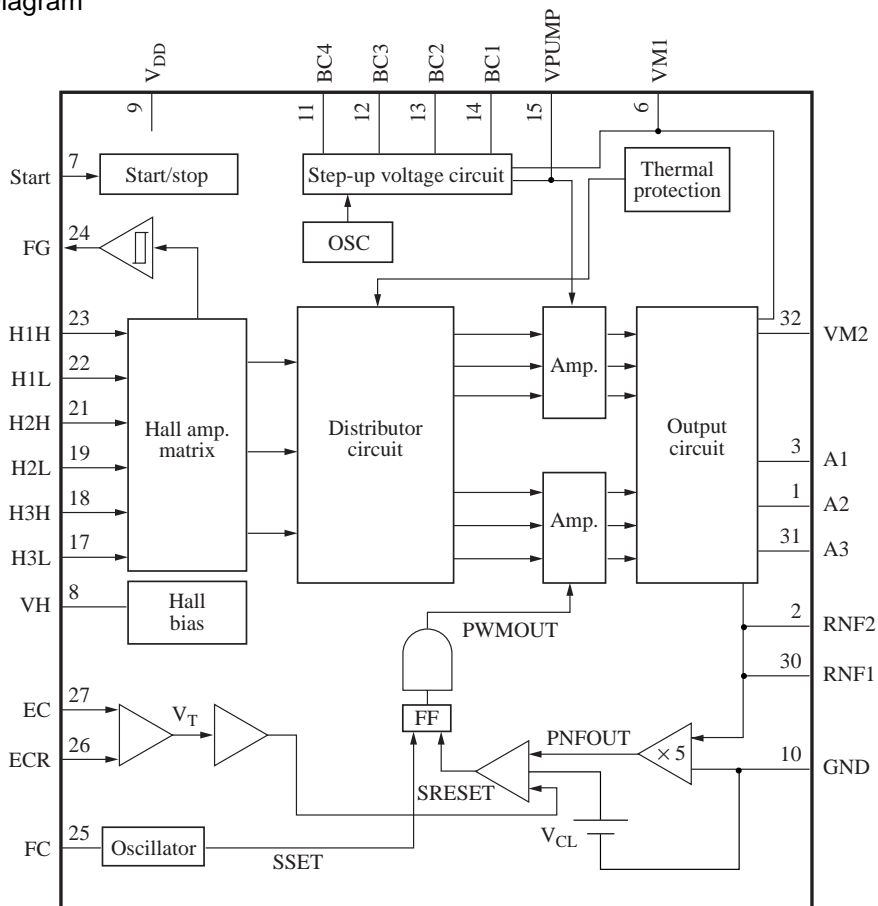

■ Pin Descriptions

Pin No.	Symbol	Description	Pin No.	Symbol	Description
1	A2	Drive output 2	17	H3L	Hall element-3 negative input pin
2	RNF2	Current det. pin 2	18	H3H	Hall element-3 positive input pin
3	A1	Drive output 1	19	H2L	Hall element-2 negative input pin
4	N.C.	N.C.	20	N.C.	N.C.
5	N.C.	N.C.	21	H2H	Hall element-2 positive input pin
6	VM1	Motor supply voltage pin 1	22	H1L	Hall element-1 negative input pin
7	Start	Start/stop changeover pin	23	H1H	Hall element-1 positive input pin
8	VH	Hall bias pin	24	FG	FG signal output pin
9	V _{DD}	Supply voltage pin	25	FC	Oscillator pin
10	GND	Ground pin	26	ECR	Torque command reference input pin
11	BC4	Booster capacitor connection pin 4	27	EC	Torque command input pin
12	BC3	Booster capacitor connection pin 3	28	N.C.	N.C.
13	BC2	Booster capacitor connection pin 2	29	N.C.	N.C.
14	BC1	Booster capacitor connection pin 1	30	RNF1	Current det. pin 1
15	VPUMP	Booster pin	31	A3	Drive output 3
16	N.C.	N.C.	32	VM2	Motor supply voltage pin 2

■ Absolute Maximum Ratings

Parameter	Symbol	Rating	Unit
Supply voltage *2	V _{DD}	6.0	V
	V _{M1}		
	V _{M2}		
Drive output voltage *5	V _(m)	15.0	V
Control signal input voltage *6	V _(n)	0 to V _{DD}	V
Supply current	I _{DD}	30.0	mA
Drive output current *4	I _(o)	±1 200	mA
Hall bias current	I _{HB}	30.0	mA
Power dissipation *3	P _D	293	mW
Operating ambient temperature *1	T _{opr}	-20 to +70	°C
Storage temperature *1	T _{stg}	-55 to +150	°C

Note) Do not apply external currents or voltages to any pins not specifically mentioned.

For circuit currents, '+' denotes current flowing into the IC, and '-' denotes current flowing out of the IC.

*1: Except for the operating ambient temperature and storage temperature, all ratings are for T_a = 25°C.

*2: The voltage in the step-up voltage circuit exceeds the supply voltage.

For the allowable value of the step-up voltage, refer to "■ Electrical Characteristics".

*3: For 70°C and IC alone.

*4: o = 1, 2, 3, 6, 30, 31, 32

*5: m = 1, 3, 31

*6: n = 7, 17, 18, 19, 21, 22, 23, 26, 27

■ Recommended Operating Range

Parameter	Symbol	Range	Unit
Supply voltage	V_{DD}	4.5 to 5.5	V
	V_{M1}		
	V_{M2}		

■ Electrical Characteristics at $T_a = 25^\circ\text{C}$

Parameter	Symbol	Conditions	Min	Typ	Max	Unit
Overall						
Circuit current 1	I_{DD1}	$V_{DD} = 5\text{ V}$ in power save mode	—	0	0.1	mA
Circuit current 2	I_{DD2}	$V_{DD} = 5\text{ V}$	—	9	14	mA
Start/stop						
Start voltage	V_{START}	Voltage with which a circuit operates at $V_{DD} = 5\text{ V}$ and $L \rightarrow H$	2.7	—	—	V
Stop voltage	V_{STOP}	Voltage with which a circuit becomes off at $V_{DD} = 5\text{ V}$ and $H \rightarrow L$	—	—	0.7	V
Hall bias						
Hall bias voltage	V_{HB}	$V_{DD} = 5\text{ V}$, $I_{HB} = 20\text{ mA}$	0.7	1.1	1.6	V
Hall amplifier						
Input bias current	I_{BH}	$V_{DD} = 5\text{ V}$	—	1	5	μA
In-phase input voltage range	V_{HBR}	$V_{DD} = 5\text{ V}$, except for H2H, H2L	1.5	—	4.0	V
Minimum input level	V_{INH}	$V_{DD} = 5\text{ V}$	60	—	—	mV[p-p]
Torque command						
In-phase input voltage range	EC	$V_{DD} = 5\text{ V}$	0.5	—	3.9	V
Offset voltage	EC_{OF}	$V_{DD} = 5\text{ V}$	-100	0	100	mV
Dead zone	EC_{DZ}	$V_{DD} = 5\text{ V}$	0	75	150	mV
Input current	EC_{IN}	$V_{DD} = 5\text{ V}$, $EC = ECR = 2.5\text{ V}$	-5	-1	—	μA
Input/output gain	A_{CS}	$V_{DD} = 5\text{ V}$, $R_{CS} = 0.33\ \Omega$	0.36	0.48	0.60	A/V
Output						
High-level output saturation voltage	V_{OH}	$V_{DD} = 5\text{ V}$, $I_O = -500\text{ mA}$	—	0.25	0.50	V
Low-level output saturation voltage	V_{OL}	$V_{DD} = 5\text{ V}$, $I_O = 500\text{ mA}$	—	0.25	0.50	V
Torque limit current	I_{TL}	$V_{DD} = 5\text{ V}$, $R_{CS} = 0.33\ \Omega$	455	570	685	mA
OSC						
Charging current	I_{CH}	$V_{DD} = 5\text{ V}$	-65	-50	-35	μA
Upper threshold voltage	V_{CH}	$V_{DD} = 5\text{ V}$	1.75	2.50	3.25	V
Lower threshold voltage	V_{CL}	$V_{DD} = 5\text{ V}$	0.35	0.50	0.65	V

■ Electrical Characteristics at $T_a = 25^\circ\text{C}$ (continued)

Parameter	Symbol	Conditions	Min	Typ	Max	Unit
FG						
FG output high-level	FG_H	$V_{DD} = 5\text{ V}$, $I_{FG} = -0.01\text{ mA}$	3	—	—	V
FG output low-level	FG_L	$V_{DD} = 5\text{ V}$, $I_{FG} = 0.01\text{ mA}$	—	—	0.5	V
In-phase input voltage range	V_{FGR}	$V_{DD} = 5\text{ V}$	1.5	—	3.0	V
FG hysteresis width	H_{FG}	$V_{DD} = 5\text{ V}$	5	10	20	mV
Step-up circuit						
Step-up voltage	V_{PUMP}	$V_{DD} = 5\text{ V}$, $V_{M1} = V_{M2} = 5\text{ V}$	9.5	—	15	V

• Design reference data

Note) The characteristics listed below are theoretical values based on the IC design and are not guaranteed.

Parameter	Symbol	Conditions	Min	Typ	Max	Unit
Thermal protection						
Thermal protection operating temperature	T_{SDON}	$V_{DD} = 5\text{ V}$	—	170	—	$^\circ\text{C}$
Thermal protection hysteresis width	ΔT_{SD}	$V_{DD} = 5\text{ V}$	—	45	—	$^\circ\text{C}$

■ Terminal Equivalent Circuits

Pin No.	Symbol	Equivalent circuit
1	A2	
2	RNF2	
3	A1	
4	N.C.	N.C.
5	N.C.	N.C.
6	VM1	Refer to pin 1
7	Start	

■ Terminal Equivalent Circuits (continued)

Pin No.	Symbol	Equivalent circuit
8	VH	
9	V _{DD}	Supply voltage pin
10	GND	Ground pin
11	BC4	
12	BC3	
13	BC2	
14	BC1	
15	VPUMP	
16	N.C.	N.C.
17	H3L	
18	H3H	
19	H2L	
20	N.C.	N.C.

■ Terminal Equivalent Circuits (continued)

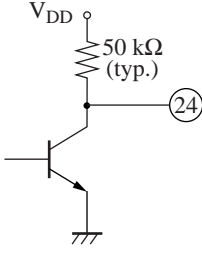
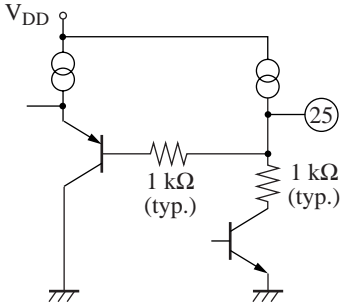
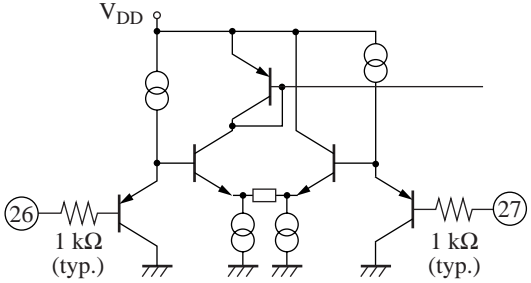
Pin No.	Symbol	Equivalent circuit
21	H2H	Refer to pin 19
22	H1L	Refer to pin 17
23	H1H	Refer to pin 17
24	FG	
25	FC	
26	ECR	
27	EC	
28	N.C.	N.C.
29	N.C.	N.C.
30	RNF1	Refer to pin 1
31	A3	Refer to pin 1
32	VM2	Refer to pin 1

■ Usage Notes

- Prevent this IC from being line-to-ground fault.

(To be concrete, do not short-circuit any of A1 (pin 3), A2 (pin 1) and A3 (pin 31) with GND pin (pin 10).)

- Be careful of the following three pins because their static breakdown voltages are low. (C = 200 pF, R = 0 Ω)

Pin 11: breakdown at 80 V

Pin 14: breakdown at 90 V

Pin 24: breakdown at 190 V

■ Application Note

- Phase conditions between Hall input and output current

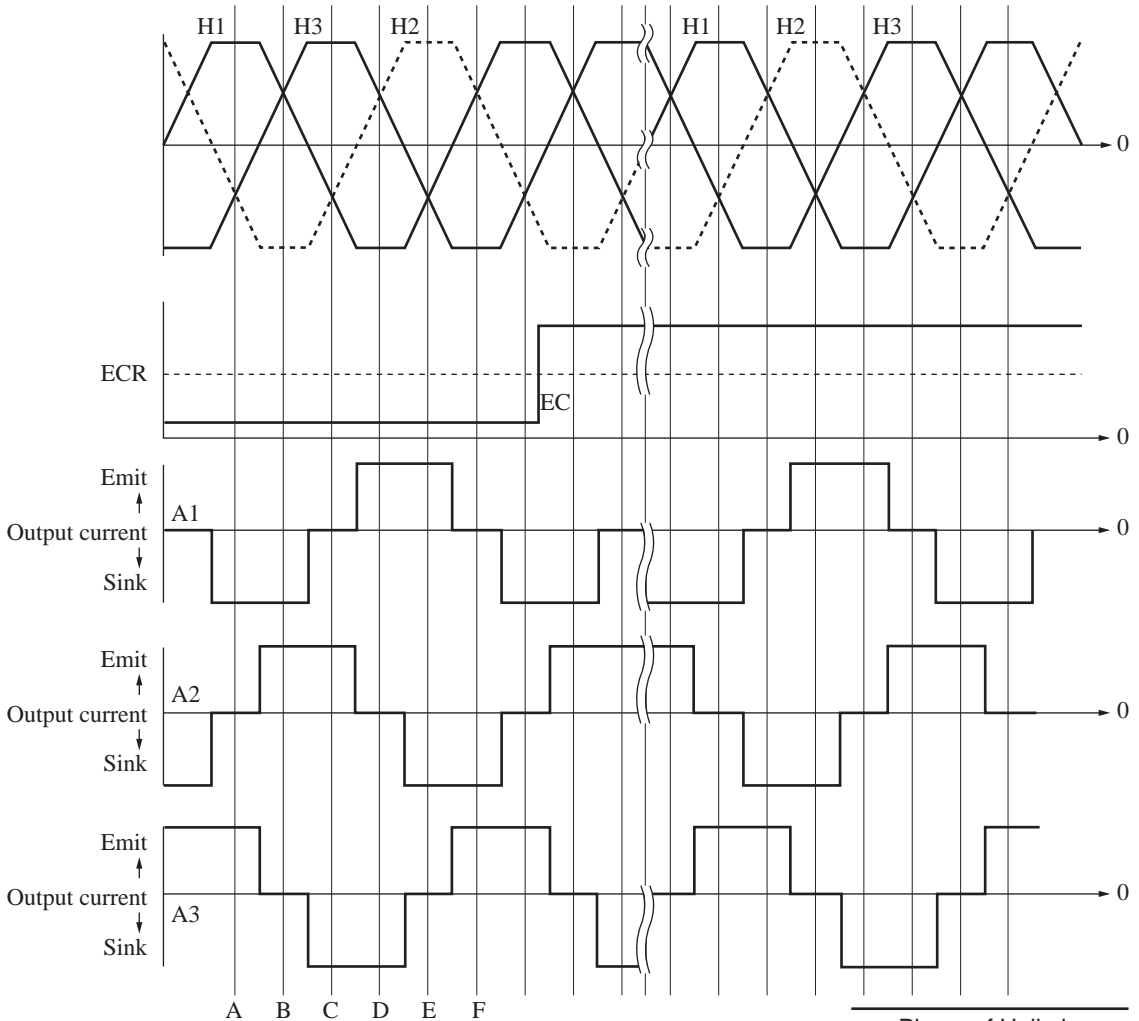

	Phase of Hall pin		
	H1H	H2H	H3H
A	H	ML	ML
B	MH	L	MH
C	ML	ML	H
D	L	MH	MH
E	ML	H	ML
F	MH	MH	L

■ Application Circuit Example

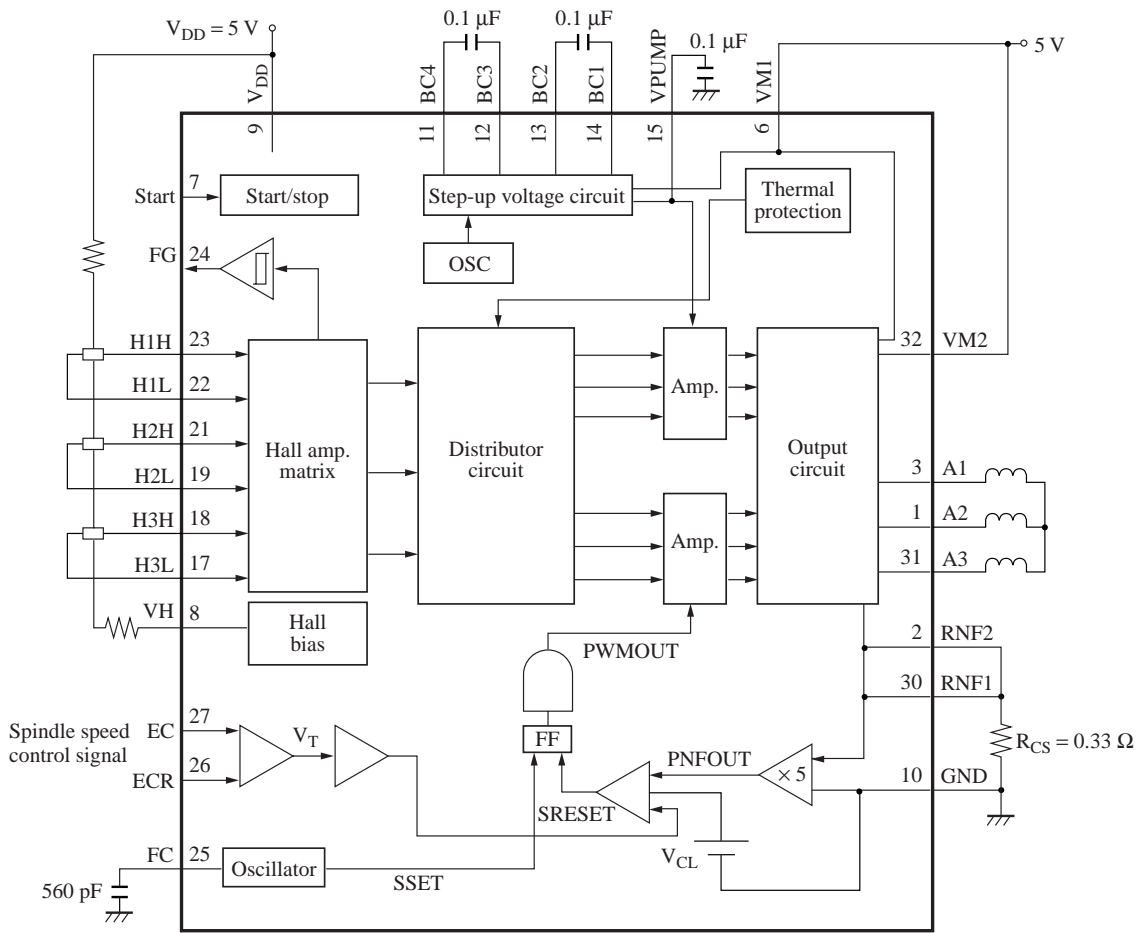



LittleDiode supplies new, hard to find or obsolete electronic components and semiconductors all over the world.

With over two million different components listed you are sure to find the part you need.

Feel free to visit us today at our online store:

LittleDiode.com

Looking forward to providing you with the best possible service.