

AN8387S

2-channel Linear Driver

■ Overview

The AN8387S is an IC which incorporates 2 circuits of BTL drivers for driving various DC motors such as actuators (focus, tracking traverse), spindles, and loading of the CD players.

■ Features

- Operating supply voltage range ; $V_{CC}=3.5V$ to $9V$
 $PV_{CC}=1.5V$ to $9V$
- Built-in 2 circuits of voltage driven BTL drivers
(maximum drive current : $500mA$)
- Quiescent current (current consumption at no input) ; $3.2mA$
- Provided with power control pin
- Provided with driver output voltage limiting pin
- Built-in thermal protective circuit
(operating temperature : $160^{\circ}C$ typ.)

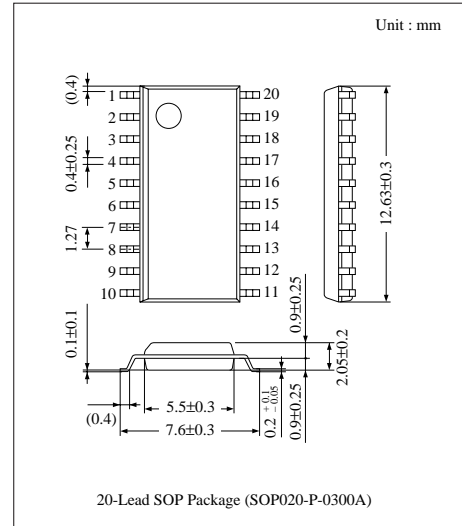

■ Applications

Linear driving of the DC motors and actuators of the CD players. CD radio cassette tape recorders, and so on.

■ Block Diagram

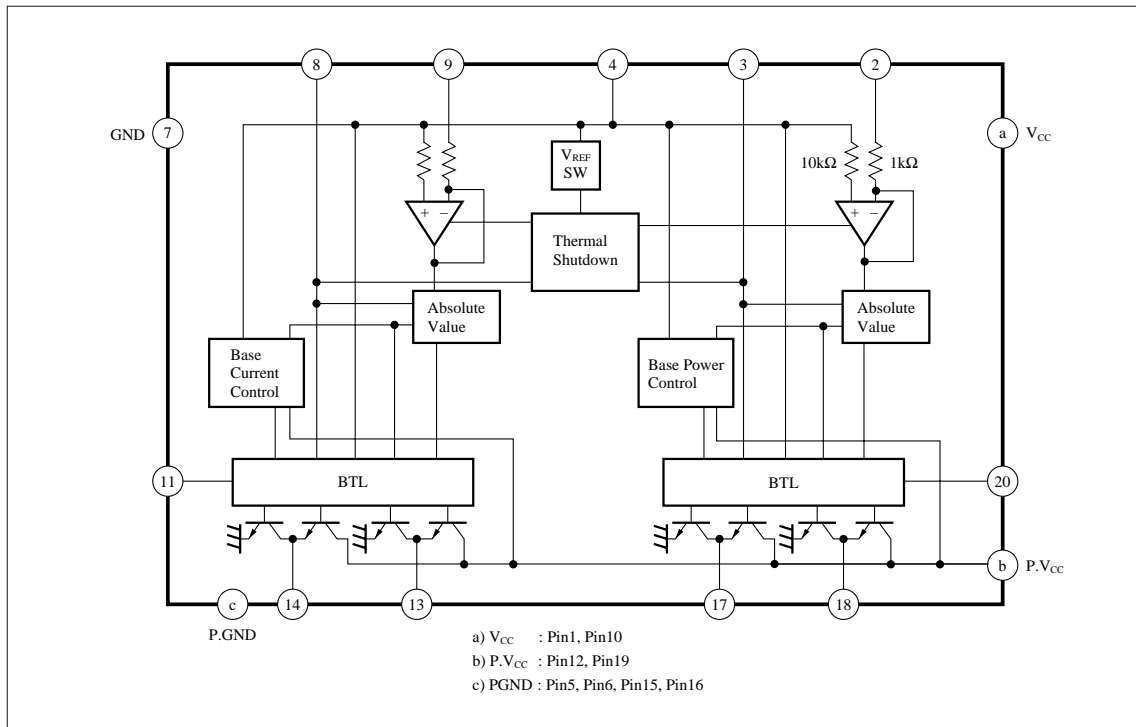

■ Absolute Maximum Ratings (Ta=25°C)

Parameter	Symbol	Rating	Unit
Supply Voltage	V _{CC}	10	V
Power Dissipation	P _D	1,200 ^{Note)}	mW
Operating Ambient Temperature	T _{opr}	-30 ~ +85	°C
Storage Temperature	T _{stg}	-55 ~ +125	°C

Note) When mounted onto the glass epoxy PCB (50mm × 50mm × 0.8mm)

■ Recommended Operating Range (Ta=25°C)

Parameter	Symbol	Range
Operating Supply Voltage Range	V _{CC}	3.5V ~ 9V
	P.V _{CC}	1.5V ~ 9V

■ Electrical Characteristics (Ta=25°C)

Parameter	Symbol	Condition	min.	typ.	max.	Unit
Current Consumption at No Input (V _{CC})	I _{VCCQ}	V _{CC} =9V, V _{ref} =4.5V, PV _{CC} =9V	1	2	3.5	mA
Current Consumption at No Input (PV _{CC})	I _{PVCCQ}	V _{CC} =9V, V _{ref} =4.5V, PV _{CC} =9V	0.7	1.2	3.5	mA
PV _{CC} Leak Current	I _{PVCCL}	V _{CC} =0V, V _{ref} =OPEN, PV _{CC} =10V	—	—	1	μA
V _{ref} Threshold (H) ^{Note 1)}	V _{refH}	V _{CC} =3V, PV _{CC} =10V, V _{IN} =0V	1.45	—	—	V
V _{ref} Threshold (L) ^{Note 2)}	V _{refL}	V _{CC} =3V, PV _{CC} =10V, V _{IN} =0V	—	—	1	V
Input Amp. Input Impedance	RA _{IN}	V _{CC} =5V, V _{ref} =2.5V, V _{IN} =2.4→2.6V	0.75	1	1.25	kΩ
Driver Input Offset Voltage ^{Note 3)}	V _{I offset}	V _{CC} =9V, V _{ref} =4.5V, PV _{CC} =9V	-10	0	10	mV
Driver Output Offset Voltage ^{Note 3)}	V _{O offset}	V _{CC} =9V, V _{ref} =4.5V, PV _{CC} =9V	-55	0	55	mV
Driver Dead Zone Width ^{Note 3)}	V _{DZ}	V _{CC} =9V, V _{ref} =4.5V, PV _{CC} =9V	-10	—	19	mV
Driver Transfer Gain (+) ^{Note 3)}	G ⁺	V _{CC} =9V, V _{ref} =4.5V, PV _{CC} =9V	13	15.1	17	dB
Driver (+), (-) Transfer Gain Ratio ^{Note 3)}	RG	V _{CC} =9V, V _{ref} =4.5V, PV _{CC} =9V	-1.9	-0.9	0.5	dB
Driver Output Voltage	V _{OLG}	V _{CC} =9V, V _{ref} =4.5V, PV _{CC} =9V, V _{LIM} =0V	-130	—	130	mV
Driver Output Voltage Absolute Value	V _{OL}	V _{CC} =9V, V _{ref} =4.5V, PV _{CC} =9V, V _{LIM} =3V	2.25	—	3	V
Driver Power Transistor Saturation Voltage	V _{sat}	V _{CC} =9V, V _{ref} =4.5V, PV _{CC} =9V, I _O =300mA	—	0.29	0.38	V
PC Input Pin Threshold Voltage (H) ^{Note 4)}	V _{PC THH}	V _{CC} =9V, V _{ref} =2.5V, PV _{CC} =5V, V _{IN} =2.3V	2.8	—	—	V
PC Input Pin Threshold Voltage (L) ^{Note 5)}	V _{PC THL}	V _{CC} =9V, V _{ref} =2.5V, PV _{CC} =5V, V _{IN} =2.3V	—	—	0.8	V
Protective Diode Forward Voltage	V _{PD}	I _O =300mA	0.9	1.5	1.8	V
Thermal Protective Circuit Operating Temperature	T _{THD}		—	160	—	°C

Note1) V_{ref} voltage required to operate the driver.

Note2) If V_{ref} is made lower than this voltage, the driver dose not operate.

Note3) Refer to the driver input/output characteristics chart.

Note4) If the PC pin voltage is made higher than this voltage, there will be no output voltage from the driver. Both (+) and (-) outputs are pulling in the current.

Note5) If the PC pin voltage is made lower than this voltage, the driver operates normally.

■ Application Circuit

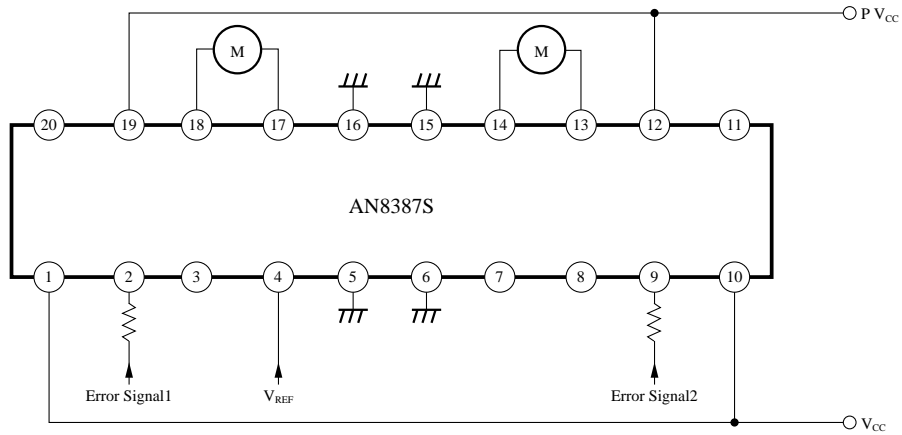

■ Pin Descriptions

Pin No.	Symbol	I/O	DC Voltage	Equivalent Circuit	Description
1 10	V _{cc}	I	4.8V		V _{cc} pin. Not connected to the PV _{cc} pin.
2	IN1	I	2.5V	<p>Operational amplifier is of PNP differential input</p>	Error signal input pin for the channel-1 driver
9	IN2	I	2.5V		Error signal input pin for the channel-2 driver
3	PC1	I	0V		Input pin for the PC (inter-output voltage of the channel-1 driver OFF)
8	PC2	I	0V		Input pin for the PC (inter-output voltage of the channel-2 driver OFF)

■ Pin Descriptions (Cont.)

Pin No.	Symbol	I/O	DC Voltage	Equivalent Circuit	Description
4	V _{ref}	I	2.5V		V _{ref} input pin
5 6 15 16	P.GND	O	0V		P.GND pin
7	GND	O	0V		GND pin
11	VLIM2	I	V _{CC}		VLIM pin for the channel-2 driver. Used when limiting the output voltage of the pins 13 and 14
20	VLIM1	I	V _{CC}		VLIM pin for the channel-1 driver. Used when limiting the output voltage of the pins 17 and 18
12 19	PV _{CC}	I	3V		Power V _{CC} pin. Supplies the driver current.

■ Pin Descriptions (Cont.)

Pin No.	Symbol	I/O	DC Voltage	Equivalent Circuit	Description
13	D2+	O	(2.7V)		Non-inverting output pin for the channel-2 driver
14	D2-	O	(0.3V)		Inverting output pin for the channel-2 driver
17	D1-	O	(0.3V)		Inverting output pin for the channel-1 driver
18	D1+	O	(2.7V)		Non-inverting output pin for the channel-1 driver

■ Supplementary Explanation

• Operational Description

The AN8387S incorporates the two channels of drivers. Since both channels have the identical functions, the following describes the channel-1 driver.

• Block Diagram (Channel 1 driver)

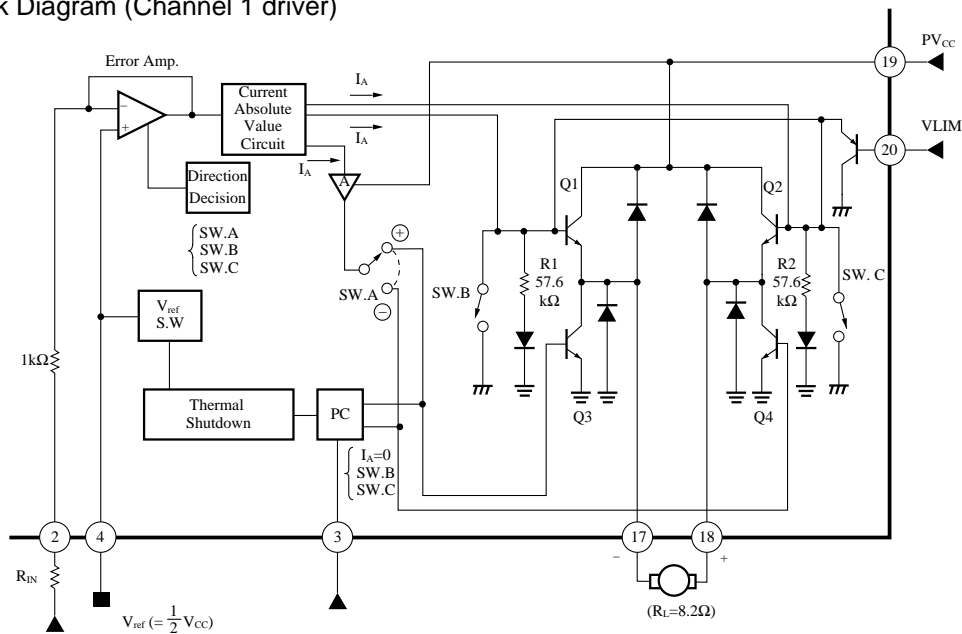

An error signal (V_{IN}) input to the pin2 is converted into the absolute value input current I_A through the error amplifier and current absolute value circuit. The value of I_A is as follows.

$$I_A = \frac{|V_{IN} - V_{ref}|}{R_{IN} + 1k\Omega}$$

1) When $V_{IN} > V_{ref}$, the direction determining circuit operates so that the following conditions are met.

- SW.A : ⊕
- SW.B : ON
- SW.C : OFF

2) When $V_{IN} < V_{ref}$, the direction determining circuit operates so that the following conditions are met.

- SW.A : ⊖
- SW.B : OFF
- SW.C : ON

The output ($V_+ - V_-$) between the pins18 and 17 has the following relation with the input ($V_{IN} - V_{ref}$) between the pins 2 and 4.

$$(V_+ - V_-) = \frac{57.6k\Omega}{R_{IN} + 1k\Omega} (V_{IN} - V_{ref})$$

Therefore, the driver's gain G will be as follows. (when the motor load R_L is 8.2Ω)

$$G = \frac{(V_+ - V_-)}{(V_{IN} - V_{ref})} = \frac{57.6k\Omega}{1k\Omega + R_{IN}}$$

The output voltage V_- of the pin17 and V_+ of the pin18 can be limited by applying a voltage to the VLIM pin20.

For example, if a voltage of 3V is applied to the pin20 when $V_{CC} = 9V$ and $R_L = 8.2\Omega$, the maximum value of $|V_+$

$-V_-|$ is limited within the following range.

$$2.25V \leq |V_+ - V_-| \leq 3V$$

When the pin20 is short-circuited to GND,

$|V_+ - V_-| \leq 130mV$ results regardless of an input error signal (V_{IN}).

If the pin20 is prepared to short-circuit to GND at power-on of the set, it can be used to prevent operation error at power-on of the motor or actuator.

When the pin20 is not used, short-circuit it to the pins1 and 10.

The pin3 is a PC pin. If a voltage of 2.8V or more is applied to this pin, SW.B and SW.C are turned on, I_A becomes 0mA, and the base current flows to the bases of Q3 and Q4 simultaneously to turn on Q3 and Q4. As a result, the pins17 and 18 are almost short-circuited to P.GND.

This IC incorporates the thermal shutdown circuit. If the chip temperature of the IC comes to about 160°C, both drivers of the two channels are turned off. (the output pins17, 18, 14, and 13 are short-circuited to P.GND)

Similarly, if the applied voltage (V_{ref}) of the V_{ref} pin4 comes to 1V or less, both drivers of the two channels are turned off.

• Driver Input/Output Characteristics

- Input Offset (V_{IOF})
- Output Offset (V_{OOF})
- Dead Zone ($|V_{DZ}|$)
- Transfer Gain (+) (G_+)
- (+), (-) Transfer Gain Ratio (R_G)

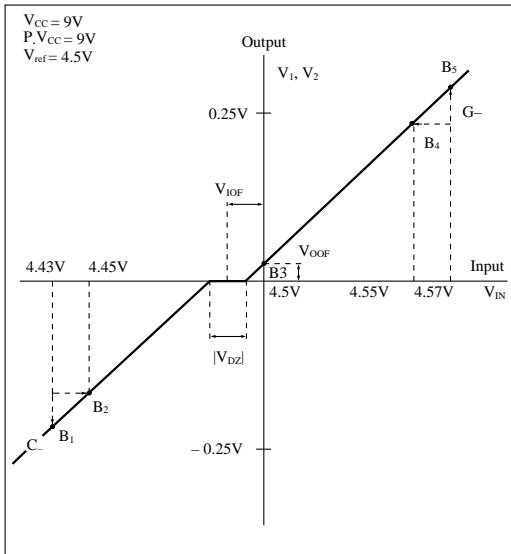

$$G_+ = \frac{B_5 - B_4}{20mV}, G_- = \frac{B_2 - B_1}{20mV}, R_G = \frac{G_+}{G_-}$$

• Characteristics Curve

$P_D - T_a$

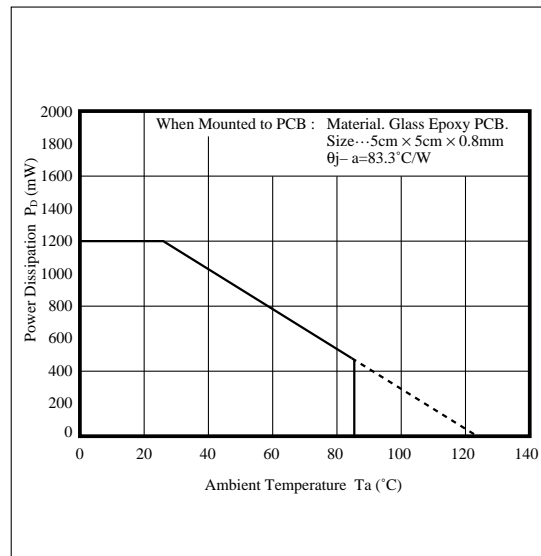



LittleDiode supplies new, hard to find or obsolete electronic components and semiconductors all over the world.

With over two million different components listed you are sure to find the part you need.

Feel free to visit us today at our online store:

LittleDiode.com

Looking forward to providing you with the best possible service.