Application Note

**Crystal LAN™ CS8900A ETHERNET CONTROLLER
TECHNICAL REFERENCE MANUAL**

By Deva Bodas
Revised by James Ayres

TABLE OF CONTENTS

SCHEMATIC CHECKLIST	4
SOFTWARE CHECKLIST	5
INTRODUCTION TO CS8900A TECHNICAL REFERENCE MANUAL	6
HARDWARE DESIGN	7
CS8900A: CONNECTING TO NON-ISA BUS SYSTEMS	7
The CS8900A Architecture	7
ISA Bus	8
CS8900A in I/O Mode	8
CS8900A in Memory Mode	8
DMA Interface of the CS8900A	8
Selection of I/O, Memory and DMA Modes	9
Design Example: CS8900A Interface to MC68302	9
Address Generation	9
Read and Write Signals	10
SBHE Signal	10
Other Control Signals	10
Status Signals from CS8900A	11
Databus (SD[0:15]) Connection	11
Checklist for Signal Connections to the CS8900A	11
EEPROM Optional	11
Design Example: CS8900A Interface to Cirrus Logic CL-PS7111	12
Design Example: CS8900A Interface to Hitachi SH3	12
Summary	12
ETHERNET HARDWARE DESIGN FOR EMBEDDED SYSTEMS AND MOTHERBOARDS	15
General Description	15
Board Design Considerations	15
Crystal Oscillator	15
ISA Bus Interface	15
External Decode Logic	15
EEPROM	15
LEDs	18
10BASE-T Interface	18
10BASE-2 and AUI Interfaces	18
Logic Schematics	18
Component Placement and Signal Routing	20
Bill of Material	20

Contacting Cirrus Logic Support

For a complete listing of Direct Sales, Distributor, and Sales Representative contacts, visit the Cirrus Logic web site at:
<http://www.cirrus.com/corporate/contacts/>

Crystal LAN, StreamTransfer, PacketPage, and SMART *Analog* are trademarks of Cirrus Logic.

Ethernet is a registered trademark of Xerox Corp.. Artisoft and LANtastic are registered trademarks of Artisoft, Inc.. Banyan and VINES are registered trademarks of Banyan Systems.. Digital and PATHWORKS are registered trademarks of Digital Equipment Corporation.. Intel is a registered trademark of Intel Corporation.. LAN Server and IBM are registered trademarks of International Business Machines Corp.. Microsoft, LAN Manager, Windows 95, Windows for Workgroups, and Windows NT are registered trademarks of Microsoft.. Novell and Netware are registered trademarks of Novell, Inc.. SCO is a registered trademark of Santa Cruz Organization, Inc.. UNIX is a registered trademark of AT&T Technologies, Inc.

Preliminary product information describes products which are in production, but for which full characterization data is not yet available. Advance product information describes products which are in development and subject to development changes. Cirrus Logic, Inc. has made best efforts to ensure that the information contained in this document is accurate and reliable. However, the information is subject to change without notice and is provided "AS IS" without warranty of any kind (express or implied). No responsibility is assumed by Cirrus Logic, Inc. for the use of this information, nor for infringements of patents or other rights of third parties. This document is the property of Cirrus Logic, Inc. and implies no license under patents, copyrights, trademarks, or trade secrets. No part of this publication may be copied, reproduced, stored in a retrieval system, or transmitted, in any form or by any means (electronic, mechanical, photographic, or otherwise) without the prior written consent of Cirrus Logic, Inc. Items from any Cirrus Logic website or disk may be printed for use by the user. However, no part of the printout or electronic files may be copied, reproduced, stored in a retrieval system, or transmitted, in any form or by any means (electronic, mechanical, photographic, or otherwise) without the prior written consent of Cirrus Logic, Inc. Furthermore, no part of this publication may be used as a basis for manufacture or sale of any items without the prior written consent of Cirrus Logic, Inc. The names of products of Cirrus Logic, Inc. or other vendors and suppliers appearing in this document may be trademarks or service marks of their respective owners which may be registered in some jurisdictions. A list of Cirrus Logic, Inc. trademarks and service marks can be found at <http://www.cirrus.com>.

LOW COST ETHERNET COMBO CARD REFERENCE DESIGN: CRD8900	21
General Description	21
Board Design	21
Crystal Oscillator	21
ISA Bus Interface	21
External Decode Logic	21
EEPROM.....	21
Socket for Optional Boot PROM	21
LEDs	26
10BASE-T Interface	26
AUI Interface	26
10BASE-2 Interface	27
Logic Schematics.....	27
Component Placement and Routing of Signals	27
Bill of Material	27
Addressing the CS8900A: I/O Mode, Memory Mode	27
I/O Mode	27
Memory Mode.....	31
Lower Memory Mode	31
Extended Memory Mode	31
Layout Considerations for the CS8900A	35
General Guidelines	35
Power Supply Connections.....	35
Two Layered Printed Circuit Board (PCB)	35
Multi-layered Printed Circuit Board	35
Routing of the Digital Signals.....	35
Routing of the Analog Signals	35
RECOMMENDED MAGNETICS FOR THE CS8900A	44
JUMPERLESS DESIGN	45
Serial EEPROM.....	45
Reset Configuration Block	45
Driver Configuration Information.....	47
Format of Driver Configuration Block.....	47
IEEE Physical Address	49
ISA Configuration Flags	49
PacketPage Memory Base.....	50
Boot PROM Memory Base.....	50
Boot PROM Mask	50
Transmission Control	50
Adapter Configuration Word.....	51
EEPROM Revision.....	51
Manufacturing Date.....	52
IEEE Physical Address (Copy).....	52
16-bit Checksum	52
EISA ID	52
Serial Number	53
Serial ID Checksum	53
Maintaining EEPROM Information.....	54
Embedded Designs	54
BIOS-Based Design Considerations.....	54
Driver Interface with BIOS-Based Configuration	54
OBTAINING IEEE ADDRESSES	55
DEVICE DRIVERS AND SETUP/INSTALLATION SOFTWARE	56
DOS Setup and Installation Utility	56
Installation Procedure	56
CONTACTING CUSTOMER SUPPORT AT CIRRUS	57
Cirrus Web Site	57

SCHEMATIC CHECKLIST

Before getting into the meat of the technical reference manual here is a schematic checklist. It's presented here, at the beginning, to help the hardware designer implement the design quickly and easily.

- No caps across the crystal. The CS8900A implements these internally.
- 4.99K 1% resistor between pin 93 and pin 94. A common mistake is the resistor is connected to Vcc instead of ground.
- RESET is active high, not active low.
- Check addressing.
- On non-ISA systems, if the processor is Big Endian, it may be beneficial to byte swap the data lines to minimize byte swapping in software.
- SBHE (16 bit mode) -- must be low on IO or Mem address. And it must toggle at least once to put the CS8900 in 16 bit mode.
- IO and Memory Accesses: SBHE, AEN, etc. must be stable for 10ns (read) and 20ns (write) before access.
- IOCHRDY - Generally not connected in non-ISA bus.
- CHIPSEL (active low). Tie to ground if not using ELCS.
- Make sure interrupt line is active high. It is best to put a pull down (10K) on INT line since selected IRQ line is tristated during software initiated reset.
- ELCS should be pulled to ground if not used.
- EEDatIn should be pulled to ground if not used.
- 10Base-T circuit -- no caps on TX lines between isolation transformer and 10 Base-T connector.
- 10Base-T circuit -- no center tap caps on isolation transformer and 10 Base-T connector. Good to have pads, don't populate except for EMI problems.
- Isolation transformer -- start with one that does not have a common mode choke. If there are EMI considerations, then use one with common mode choke. The pin outs are the same. For 3.3V operation, use a transformer with 1:2.5 turns ration on TX and 1:1 on RX like the Halo TG41-2006N.
- For EMI problems, 1) add choke, 2) add center tap caps on isolation transformer
- If using a shielded RJ45 connector, make sure the shield pins are connected to chassis ground.
- AEN connected to ground if not using DMA.
- AEN can be used as an active low chip select if not using DMA.
- AUI Interface -- use a 1AMP fuse. MAU can use .5amps even better use a thermistor ("poly switch"). Also, use a diode so can't back-drive from an externally powered MAU. Use a Halo TnT integrated module to simplify 10Base2 interface.
- TX series termination resistors are R: 24.3 Ohm 1% (8 Ohm 1% for 3.3V)
- RX shunt termination resistor is 100 Ohm
- Put a 68pF shunt across TX on primary side (560pF for 3.3V)
- Don't use split analog/digital power and ground planes.
- Void ground/power plane from transformer to RJ45
- Put .1uF cap on each supply pin very close to CS8900

The schematic checklist and the example connection diagrams to the Hitachi SH3, Cirrus Logic CL-PS7111 and the Motorola MC68302 microprocessors should make clear the necessary the hardware connections for a wide variety of situations.

SOFTWARE CHECKLIST

- When servicing the interrupt always read the Interrupt Status Queue (ISQ) first. Process that individual event before reading the ISQ again.
 - Having read an ISQ event indicating a valid receive frame, never read the ISQ again before either 1) reading in the entire current receive frame or 2) issuing an explicit skip command. Either of these actions will correctly clear that frame from the CS8900A's internal memory.
 - Always continue reading and processing ISQ events until reading a 0x0000 from the ISQ.
- After a software or hardware reset, always wait until the SelfStatus register, bit 7 (INITD) is set before reading or writing any other registers.
 - Allow only one transmit in progress at any given time. Since the chip dynamically allocates memory between transmit and receive frames, it is possible to fill the internal buffers with transmit frames. This would prevent reception.
 - Don't reinvent the wheel. Port one of the sample drivers, if there isn't a driver for your operating system. You can find sample drivers at <http://www.cirrus.com/drivers/ethernet/>.

INTRODUCTION TO CS8900A TECHNICAL REFERENCE MANUAL

This Technical Reference Manual provides the information which will be helpful in designing a board using the CS8900A, programming the associated EEPROM, and installing and running the CS8900A device drivers. It is expected that the user of this technical reference manual will have a general knowledge of hardware design, Ethernet, the ISA bus, and networking software. Recommended sources of background information are:

ISA System Architecture by Shanley and Anderson, Mindshare Press, 1992, ISBN 1-881609-05-7

Ethernet, Building a Communication Infrastructure, by Hegering and Lapple, Addison-Wesley, 1993, ISBN 0-201-62405-2

Netware Training Guide: Networking Technologies, by Debra Niedenmiller-Chaffis, New Riders Publishing, ISBN 1-56205-363-9

As shown in the Figure 1, the CS8900A requires a minimum number of external components. The EEPROM stores configuration information such as interrupt number, DMA channel, I-O base address, memory base address, and IEEE Individual Address. The EEPROM can be eliminated on a PC motherboard if that information is stored in the system CMOS. Note also that the Boot PROM is only needed for diskless workstations that boot DOS at system power up, over the network. Also, the LEDs are optional.

The hardware design considerations for both motherboards and adapter cards are discussed in "HARDWARE DESIGN" on page 7. The EEPROM programming considerations are described in "JUMPERLESS DESIGN" on page 45.

Cirrus provides a complete set of device drivers, as discussed in "DEVICE DRIVERS AND SETUP/INSTALLATION SOFTWARE" on page 56. The drivers reside between the networking operating system (NOS) and the CS8900A. On the CS8900A side, the drivers understand how to pro-

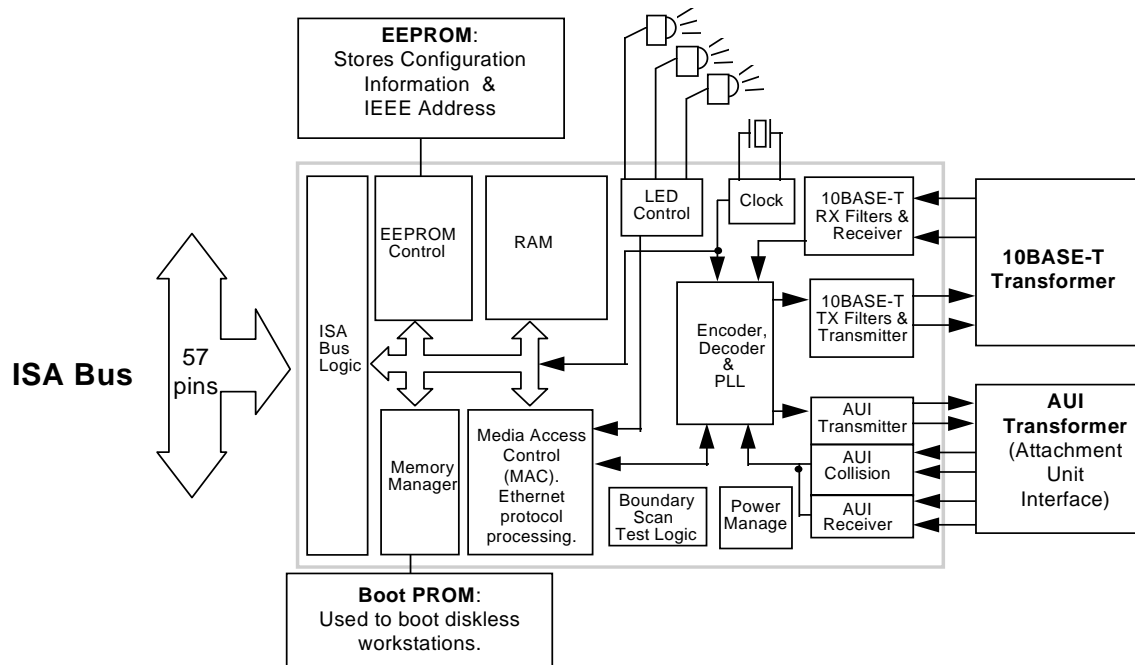

Figure 1. Hardware Application Summary

gram and read the CS8900A control and status registers, and how to transfer user data between the CS8900A and the PC main memory via the ISA bus. On the NOS side, the drivers provide the standardized services and functions required by the NOS, and hide all details of the CS8900A hardware from the NOS. The EEPROM device programs the CS8900A whenever the a hardware reset occurs, and call also store state/configuration information for the driver.

Cirrus's Software Driver (**Crystal LAN™**) Distribution Policy is as follows. The CS8900A developer kit contains a single-user copy of object code which is available only for internal testing and evaluation purposes. This object code may not be distributed without first signing a LICENSE FOR DISTRIBUTION OF EXECUTABLE SOFTWARE, which may be obtained by contacting your sales representative. The LICENSE FOR DISTRIBUTION OF EXECUTABLE SOFTWARE gives you unlimited, royalty-free rights to distribute Cirrus-provided object code.

HARDWARE DESIGN

This section give design guidance for both embedded and adapter card designs, including recommendations for dealing with the upper ISA address lines (LA[20:23]), choosing transformers, and laying out the board.

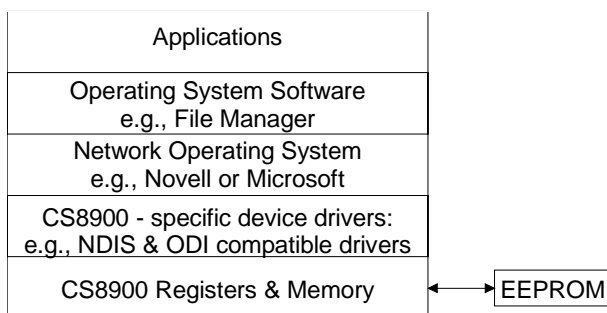

Figure 2. Software Application Summary

CS8900A: CONNECTING TO NON-ISA BUS SYSTEMS

The CS8900A includes a direct interface to the ISA bus. At the same time, the CS8900A offers a compact, efficient, and cost-effective, full-duplex Ethernet solution for non-ISA architectures. The purpose of this section is to illustrate how to interface the CS8900A to non-Intel and non ISA systems. Design examples include the MC68302, Cirrus Logic CL-PS7111 ARM and Hitachi SH3.

The CS8900A Architecture

The CS8900A is a highly integrated Ethernet controller chip. It includes the digital logic, RAM and analog circuitry required for an Ethernet interface. This high level of integration allows a product designer to design an Ethernet interface in 1.5 square inches of space on a printed circuit board. The CS8900A has a powerful memory manager that dynamically allocates the on-chip memory between transmit and receive functions. The on-chip memory manager performs functions in hardware that are many times done by software. This reduces loading on the CPU and on the bus connected to the CS8900A. In fact, for 10 Megabit Ethernet, the CS8900A is the highest throughput solution in the market.

The integration of the analog transmit waveform filtering makes it easier to design a board that will pass EMC testing. When the analog filters are external, the PCB traces have fast edge digital waveforms coming out of the IC's 10BASE-T transmitter. The presence of high frequency energy in the fast edges causes major problem during EMC tests, such as FCC Part 15 class (B) or CISPR class (B). The 10BASE-T signals driven out of the CS8900A are internally filtered with a 5th order Butterworth filter and the signals lack fast edges. Lack of high frequency signals makes it straight forward to design a card that meets FCC class (B) or even CISPR class (B) requirements.

ISA Bus

An ISA bus is a simple, asynchronous bus that can easily be made to interface to most synchronous or asynchronous buses. An ISA bus has separate address and data lines as well as separate control lines for read and write. ISA supports IO address space of 64K bytes and Memory address space 32 Mega bytes.

CS8900A in I/O Mode

When the CS8900A is used in an IO mode, it responds in the IO address space of the ISA. The CS8900A responds to an IO access when

- Either of the bus IO command lines ($\overline{\text{IOR}}$ or $\overline{\text{IOW}}$) is active,
- The address on bus signals SA[0:15] matches the address in the CS8900A IO base address register, and
- Bus signals $\overline{\text{AEN}}$, $\overline{\text{REFRESH}}$, $\overline{\text{TEST}}$, $\overline{\text{SLEEP}}$ and RESET are inactive.

All other control signals are ignored for the IO operation.

In an IO mode, the CS8900A uses 16 bytes of IO address space. The address map for this mode is described in Table 4.5 in the CS8900A datasheet.

CS8900A in Memory Mode

When the CS8900A is used in memory mode, the CS8900A responds in the memory address space of the ISA bus. The CS8900A responds to a memory mode access when

- The $\overline{\text{CHIPSEL}}$ pin is active,
- Either of the bus memory command lines ($\overline{\text{MEMR}}$ or $\overline{\text{MEMW}}$) is active,
- Both of the IO command lines ($\overline{\text{IOR}}$ and $\overline{\text{IOW}}$) are inactive,
- the address on bus signals SA[0:19] matches the address in the CS8900A's Memory Base address register,
- MemoryE (Bit A) in the CS8900A's BusCTL (Register 17) is active and,
- Bus signals $\overline{\text{AEN}}$, $\overline{\text{REFRESH}}$, $\overline{\text{TEST}}$, $\overline{\text{SLEEP}}$ and RESET are inactive.

In memory mode, all the internal registers of the CS8900A can be accessed directly via memory reads/writes. Please refer to the CS8900A datasheet for the memory address map.

DMA Interface of the CS8900A

The CS8900A can interface to an external 16-bit DMA channel for receive operations. A DMA-mode receive operation can be selected by setting either RxDMAOnly (bit 9) or AutoRxDMA (bit 10) in the CS8900A's RxCFG (Register 3) register. The CS8900A will request services of an external DMA after a receive frame is accepted by the CS8900A, completely received and stored in on chip RAM of the CS8900A. The CS8900A generates a request for DMA access (DRQx) signal when it has at least one receive frame that can be transferred to the system memory. The external DMA channel should assert $\overline{\text{DMACK}}$ signal when it is ready to transfer data. The DMA controller generates address for the system memory and asserts the $\overline{\text{AEN}}$ signal. When $\overline{\text{DMACK}}$ and $\overline{\text{AEN}}$ signals are asserted, the CS8900A provides 16 bits of frame data for every pulse of the $\overline{\text{IOR}}$ signal. Notice that the CS8900A ignores address on the SA address lines for this operation. In this way the CS8900A supports "direct mode" of operation of DMA. In direct mode, the external DMA controller generates addresses for the system RAM, and generates the appropriate control signals for the RAM and IO device. The data moves directly from the IO device to the RAM. In the case of the CS8900A, the DMA controller generates a write signal for RAM and a read signal for the CS8900A. The data flows directly from the CS8900A to the system RAM. The direct mode of DMA operation is 100% more efficient than typical read-followed-by-write DMA operation.

The length of time that the CS8900A holds the DRQ signal active depends upon the DMABurst (bit B) bit of the BusCTL (Register 17) register. If the DMABurst is clear, the DRQ remains active as

long as the CS8900A contains frames completely received. If 'n' words are to be transferred from the CS8900A to the system RAM, the DRQ signal remains active until the (n-1)th word is transferred. If the DMABurst is set, then the CS8900A deasserts DRQ signal for 1.3 μ s after every 28 μ s. This option is provided so that in a system where multiple DMA channels are operational, the DMA used for the CS8900A will not take over the system bus for long periods of time.

Selection of I/O, Memory and DMA Modes

The CS8900A always responds to all IO-mode requests. After any reset, the CS8900A responds to default IO base address of 0300h. However, this default IO address can be changed by writing a different base address into a EEPROM connected to the CS8900A. After any reset, the CS8900A reads the contents of the EEPROM. If the EEPROM is found valid, then the information in the EEPROM is used by the CS8900A to program its internal registers.

Memory mode in the CS8900A can be enabled by programming a proper base-address value in the Memory Base Address register and setting the MemoryE bit. Enabling of the memory mode can be done by software or through an EEPROM connected to the CS8900A.

In an IO mode, the CS8900A takes the minimum space (16 bytes) in the system address space. For systems where the address space limited, the IO mode is a proper choice.

The memory mode is the most direct and efficient mode of operation for the CS8900A. In the memory mode the CS8900A occupies 4K of the address space. The software can access any of the internal registers of the CS8900A directly. This reduces accesses to the CS8900A by half when accessing registers.

In a system design, even if CS8900A is used in the memory mode, the designer should make provi-

sions for accessing the CS8900A in the IO mode. This dual-mode access has two advantages.

- 1) If an EEPROM is not used in the Ethernet design, the application can address the CS8900A in IO mode (0300h) in order to enable memory mode.
- 2) When the EEPROM is used, the EEPROM is usually blank when a board is manufactured. The CS8900A must be accessed in IO mode in order to program the EEPROM.

Use of DMA for receive is efficient in a multi-tasking environment where the CPU could be busy servicing several higher priority tasks before it can service receive frames off the Ethernet wire.

Design Example: CS8900A Interface to MC68302

In this example the CS8900A is connected to Motorola micro-controller MC68302. Please refer to Figure 3 to check the connection of control signals between CS8900A and Motorola's micro-controller MC68302.

Address Generation

The MC68302 has address decode generation logic internal to the micro-controller. It generates chip select signals such as $\overline{CS1}$. In this example the $\overline{CS1}$ is used to access the CS8900A in IO as well as in Memory mode. The behavior of the $\overline{CS1}$ signal from the MC68302 is governed by values programmed in the CS1 base address register and the CS1 option register. For example, if the CS1 base address register is programmed as 3A01h, the $\overline{CS1}$ will have a base address of D00xxxh. The CS1 operation register controls the address range, number of wait states (to be inserted automatically), etc. It is recommended that the CS8900A be assigned 8K of address space (0D00000h-0D01FFFh). Memory mode of the CS8900A is enabled with the memory base address register with a value 001000h. The address line A12 separates IO address space and memory address space. When A12 is low, the

CS8900A is accessed in an IO mode and when A12 is high, the CS8900A is accessed in memory mode. When the MC68302 generates address 0D00300h, the address seen by the CS8900A will be 00300h with one of the IO commands ($\overline{\text{IOR}}$ or $\overline{\text{IOW}}$) active. Similarly when the MC68302 generates address 0D01400h, the address seen by the CS8900A will be 01400h with one of its memory commands ($\overline{\text{MEMR}}$ or $\overline{\text{MEMW}}$) active. For a MC68302, you can also specify the number of wait states that should be inserted automatically when address space assigned to CS1 is accessed. The number of wait states used depends upon the clock input to the MC68302. Please do a complete timing analysis before defining wait states.

Read and Write Signals

The combination of OR gates and an inverter shown in Figure 3, generates IO commands ($\overline{\text{IOR}}$, $\overline{\text{IOW}}$) as well as memory commands ($\overline{\text{MEMR}}$, $\overline{\text{MEMW}}$) for the CS8900A. Since the CS1 gates

these signals, the IO or memory commands are not generated unless the address on the address bus is stable. Further, for an access in memory mode, an IO command is not active.

$\overline{\text{SBHE}}$ Signal

The CS8900A is a 16 bit device and it should be used as a 16 bit device. However, after a hardware or software reset, the CS8900A behaves as an 8 bit device. Any transition on pin $\overline{\text{SBHE}}$ places the CS8900A into 16-bit mode. Further, for a 16-bit access, the $\overline{\text{SBHE}}$ pin of the CS8900A must be low. In the design example, the CPU address line A0 is connected to $\overline{\text{SBHE}}$. Before any access to the CS8900A, the design must guarantee one transition on $\overline{\text{SBHE}}$ pin.

Other Control Signals

All other control signals can be tied HIGH or LOW. The signal $\overline{\text{REFRESH}}$, $\overline{\text{TEST}}$, $\overline{\text{SLEEP}}$, AEN should be tied inactive.

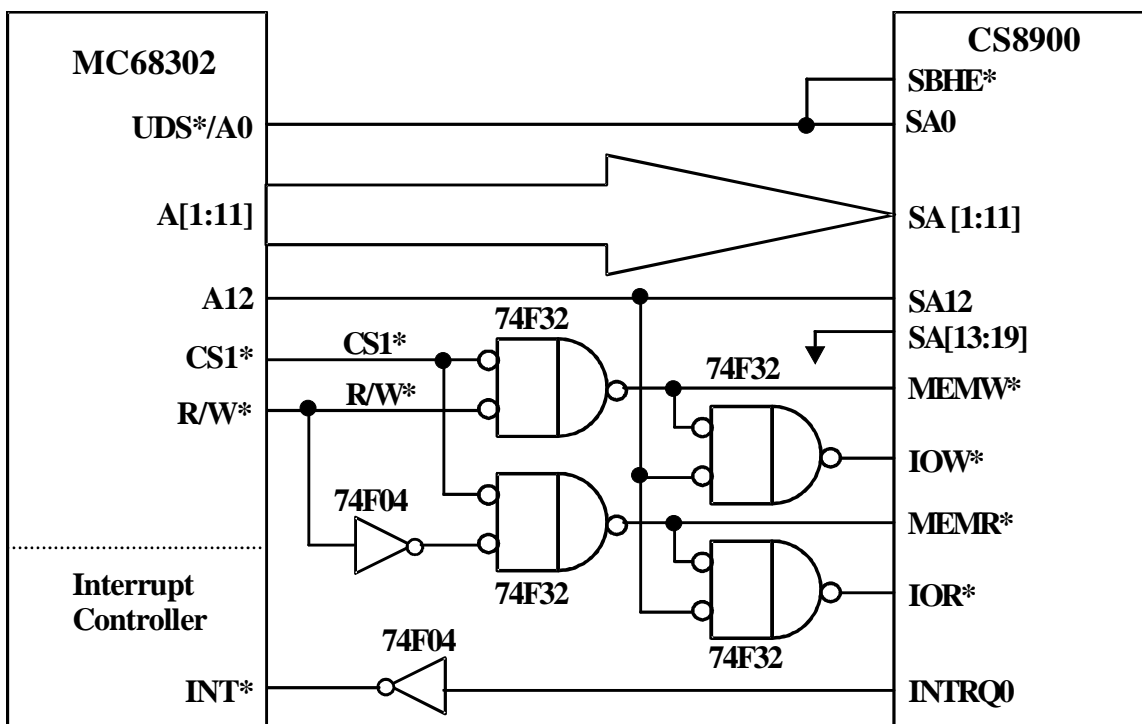

Figure 3. Connection of CS8900A to MC68302

Status Signals from CS8900A

There are several status signals that are output from the CS8900A, such as IOCHRDY, $\overline{\text{IOCS16}}$, $\overline{\text{MCS16}}$, etc. In the most embedded designs, they are not needed. Those pins from the CS8900A should be left open.

Databus (SD[0:15]) Connection

All the internal registers of the CS8900A are 16 bit wide. For all the registers, bit F of the register is access via SD15 and bit 0 of register is accessed via SD0.

To be compatible with byte ordering with ISA bus, the CS8900A provides the bytes received from the Ethernet wire in the following fashion. Assume that the data received from the Ethernet wire is 01, 02, 03, 04, 05, ... where the 01 is the first byte, 02 is the second byte and so on. When the CS8900A transfers that data to the host CPU, the data words are read from the CS8900A as 0201, 0403, etc. For certain microprocessor systems, the designer may prefer to read the data as 0102, 0304, etc. In such a case, the databus connections to the CS8900A can be altered by connecting the CPU databus D[0:7] to the SD[8:15] pins of the CS8900A and the CPU databus D[8:15] to the SD[0:7] pins of the CS8900A. In such a case, make sure that all the register and bit definitions in the CS8900A are also byte swapped. Information that is normally appears at bits [0:7] will now appear on bits [8:15], and information that usually appears on bits [8:15] will now appear on bits [0:7].

Checklist for Signal Connections to the CS8900A

Please refer to the datasheet for the CS8900A for the pin assignment and pin descriptions of various signals discussed in this section.

Clock: There are two options for the clock connection to the CS8900A. You may connect a 20.000 MHz crystal between XTL1 (pin 97) and XTL2 (pin 98) pins of the CS8900A. Or, if there a 20

MHz clock available in the system, it can be connected to the XTL1 (pin 97) pin of the CS8900A. It is important that this clock be TTL or CMOS with 40/60 duty cycle and ± 50 ppm accuracy.

$\overline{\text{SBHE}}$ signal: It is recommended that the CS8900A be used in 16-bit mode. After a hardware or software reset, the CS8900A comes up as an 8-bit device. A transition on $\overline{\text{SBHE}}$ signal (pin 36) makes the CS8900A function as a 16-bit device. After this transition, the $\overline{\text{SBHE}}$ can be kept low. For a 16-bit access of the CS8900A, the $\overline{\text{SBHE}}$ and address line SA0 (pin 37) must be low. Un-aligned word accesses to the CS8900A are not supported. In a system, the $\overline{\text{SBHE}}$ line can be connected to address line SA0. In such a case, after a hardware or software reset, do a dummy read from an odd address to provide transition on the $\overline{\text{SBHE}}$ line. For memory mode, there is one more alternative for the $\overline{\text{SBHE}}$ connection. For a memory mode operation, if a $\overline{\text{CHIPSEL}}$ pin is controlled by an external chip select, the $\overline{\text{CHIPSEL}}$ can be connected to the $\overline{\text{SBHE}}$. In this case, after a hardware and software reset, do a dummy access to the CS8900A and ignore data.

EEPROM Optional

The CS8900A has an interface for a serial EEPROM. Most of the networking applications use this EEPROM to store IEEE MAC (Media Access Control) address. Since the CS8900A supports 1 or 2 Kbits of EEPROM, the EEPROM is also used to store information such as hardware configuration, software driver configuration, etc. Any location in the EEPROM can be read or written through the CS8900A.

You will require EEPROM if the IO address for the CS8900A has to be other than 0300h, or the only mode supported by the CS8900A is memory mode. For all other cases an EEPROM is optional. However, most of the software drivers supplied by Cirrus assume that there is an EEPROM connected to the CS8900A or driver configuration data is stored

in BIOS. If the designer intends to use Cirrus supplied drivers and does not use an EEPROM or store driver configuration data in BIOS, then Cirrus supplied drivers must be modified by the designer.

We recommend that the system store the individual IEEE MAC address in a non-volatile memory somewhere in the system, and that the end-user of the system not be allowed to create an arbitrary address. In a LAN, the existence of network nodes that use the same MAC address will cause severe network problems including destruction of data and failure of various network nodes.

Design Example: CS8900A Interface to Cirrus Logic CL-PS7111

This design is similar to the MC68302 except that only the I/O mode data access is supported. This completely eliminates glue logic. See Figure 4. The highlights of the design are:

- CS8900A I/O space mapped into 7111 memory
- 3 address lines - offset by 1 due to 7111's 32 bit data accesses
- A8 and A9 tied high
- AEN used as active low chip select
- SBHE tied to 7111 chip select
- Only 16 bit accesses

Design Example: CS8900A Interface to Hitachi SH3

This design is almost identical to the CL-PS7111 connection diagram. It uses I/O mode only, eliminating glue logic. See Figure 5. The highlights of the design are:

- CS8900A I/O space mapped into SH3 memory
- 3 address lines - A0 is tied to ground.
- A8 and A9 tied high
- AEN used as active low chip select
- SBHE tied to SH3 chip select
- Inverter on the IRQ line.
- Only 16 bit accesses

Summary

The CS8900A can be interfaced to most non-ISA system with very minimum or no external logic. This allows a low cost, small size and very efficient Ethernet solution for non-ISA systems. Cirrus Logic will provide support for non-ISA designs, including logic schematic review and layout review for design engineers. Those reviews help prevent logic errors, and help to minimize EMI emissions.

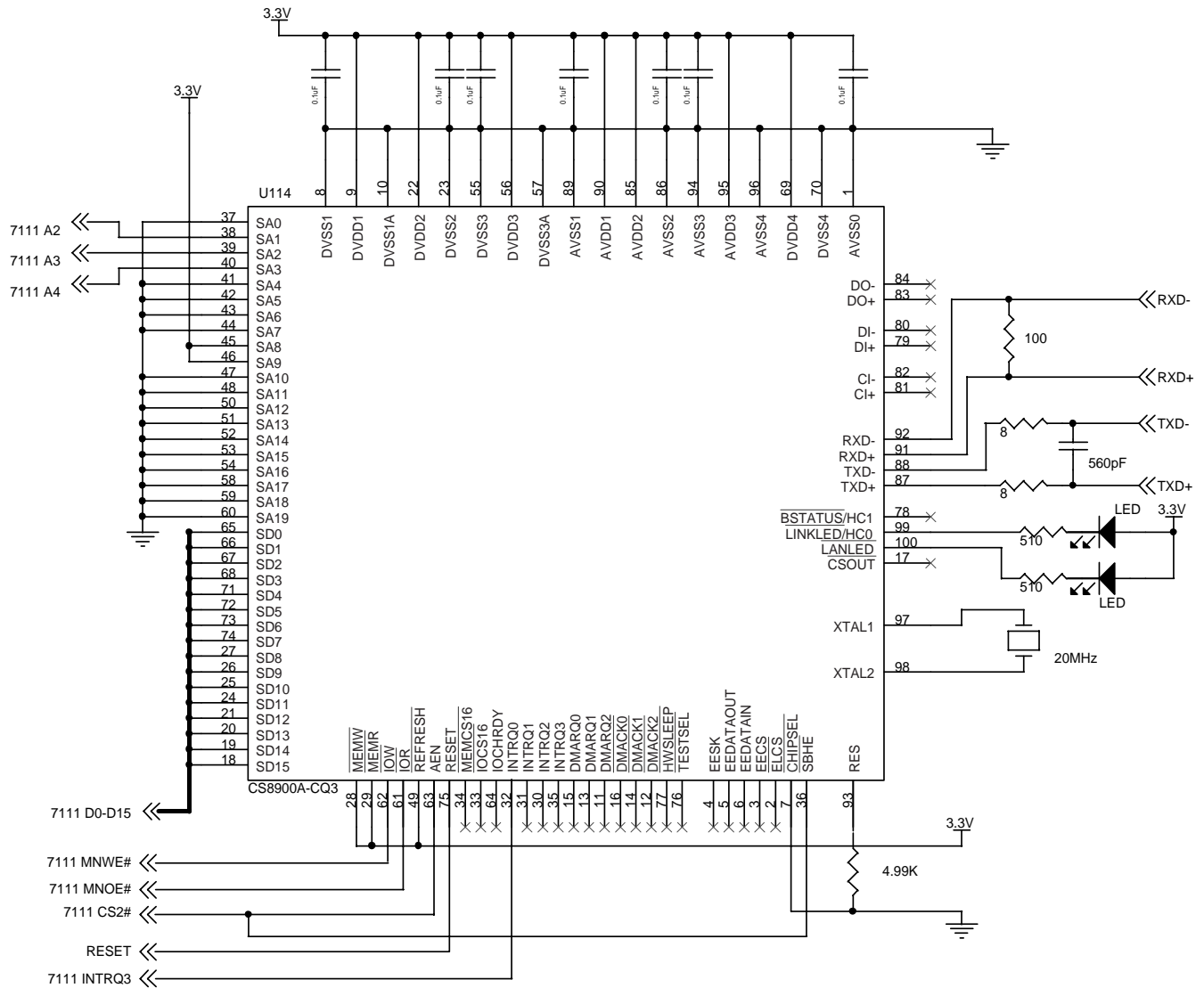

Figure 4. CS8900A Interface to Cirrus Logic CL-PS7111

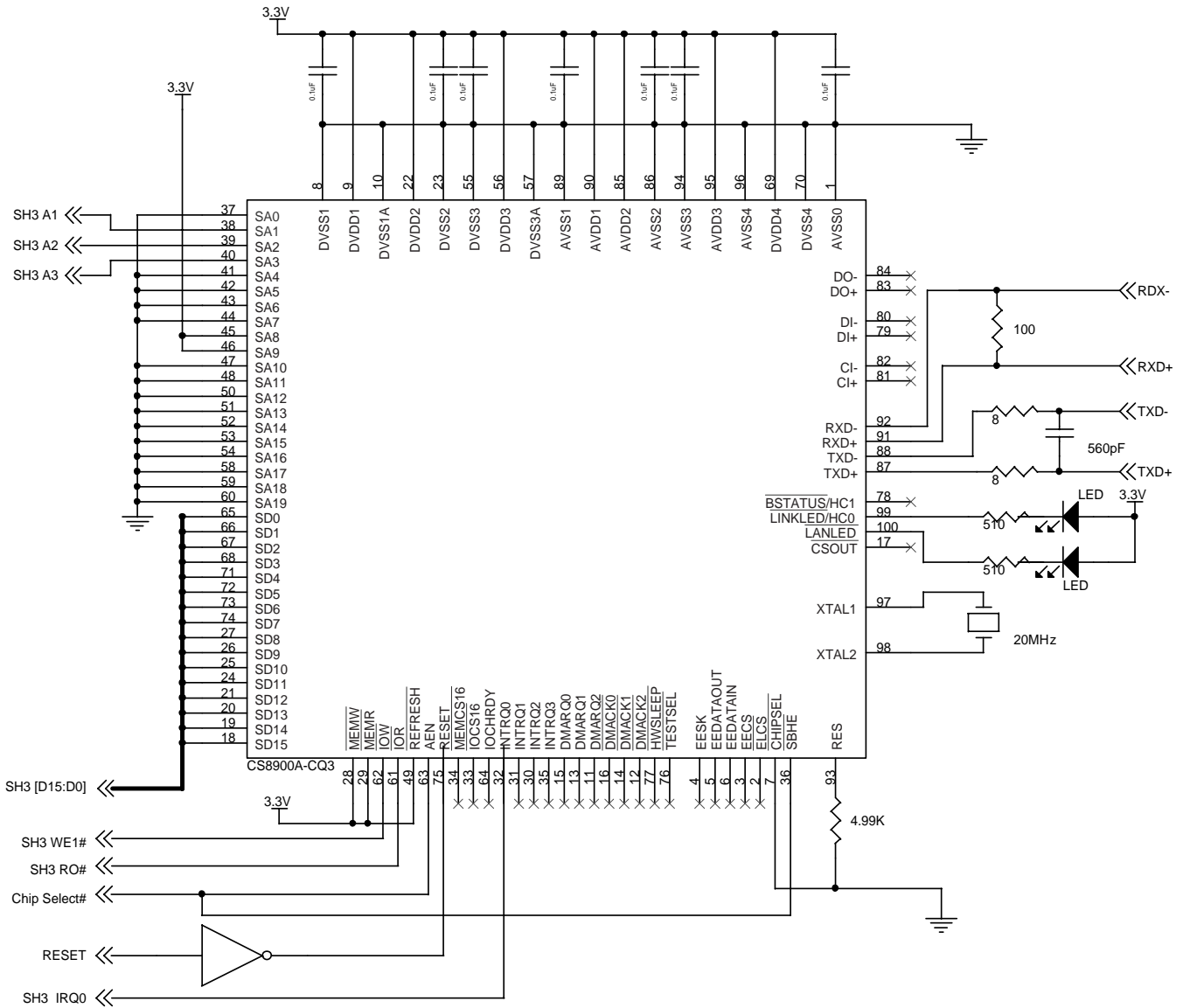

Figure 5. CS8900A Interface to Hitachi SH3

ETHERNET HARDWARE DESIGN FOR EMBEDDED SYSTEMS AND MOTHERBOARDS

This section describes the hardware design of a four-layer, 10BASE-T solution intended for use on PC motherboards, or in other embedded applications. The goal of this design is minimal board space and minimal material cost. Therefore, a number of features (BootPROM, AUI, 10BASE-2) are not supported in this particular PCB design. An example of this circuit is included in this technical reference manual, and is implemented in an ISA form factor. This same circuit can be implemented directly on the processor PCB.

General Description

The small footprint, high performance and low cost of the CS8900A Ethernet solution, makes the CS8900A an ideal choice for embedded systems like personal computer (PC) mother boards. The very high level of integration in the CS8900A results in a very low component count Ethernet design. This makes it possible to have a complete solution fit in an area of 1.5 square inches.

Board Design Considerations

Crystal Oscillator

The CS8900A, in this reference design, uses a 20.000 MHz crystal oscillator. The CS8900A has internal loading capacitance of 18pF on the XTAL1 and XTAL2 pins. No external loading capacitors are needed. Please note that the crystal must be placed very close to XTL1 and XTL2 pins of the CS8900A.

This crystal oscillator can be eliminated if accurate clock signal (20.00 MHz \pm 0.01% and 45-55 duty cycle) available in the system.

ISA Bus Interface

The CS8900A has a direct ISA bus interface. Note that the ISA bus interface is simple enough to allow

the CS8900A to interface with variety of microprocessors directly or with the help of simple programmable logic like a PAL or a GAL.

This reference design uses the ISA adapter card form factor. All the ISA bus connections from the CS8900A are directly routed to the ISA connector. The pin-out of the CS8900A is such that if the CS8900A is placed as shown in Figures 6 and 7, there will be almost no cross-over of the ISA signals.

External Decode Logic

The CS8900A can be accessed in I/O mode or memory mode. For this reference design, in memory mode the CS8900A is in the conventional or upper memory of the PC. That is, it resides in the lower 1 Mega bytes of address space.

To use the CS8900A in extended memory address space requires an external address decoder. This decoder decodes upper 4 bits (LA[20:23]) of 24 bit ISA address lines. In many embedded microprocessors such decodes are available though the microprocessors itself.

Please refer to “Extended Memory Mode” on page 31 for further information.

EEPROM

A 64 word (64 X16 bit) EEPROM (location U3) is used in the reference design to interface with the CS8900A. This EEPROM holds the IEEE assigned Ethernet MAC (physical) address for the-board (see “Obtaining IEEE Addresses” on page 55). The EEPROM also holds other configuration information for the CS8900A. The last few bytes of the EEPROM are used to store information about the hardware configuration and software requirements.

In an embedded system, such as a PC, the system CMOS RAM or any other non-volatile memory can be used to store the IEEE address and Ethernet configuration information. In such a case an EE-

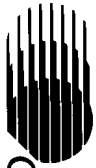

CRYSTAL SEMICONDUCTOR CORPORATION CS8900 EVAL BOARD REV. B P/N CDB8900B

Figure 6. Placement of Components, Top Side

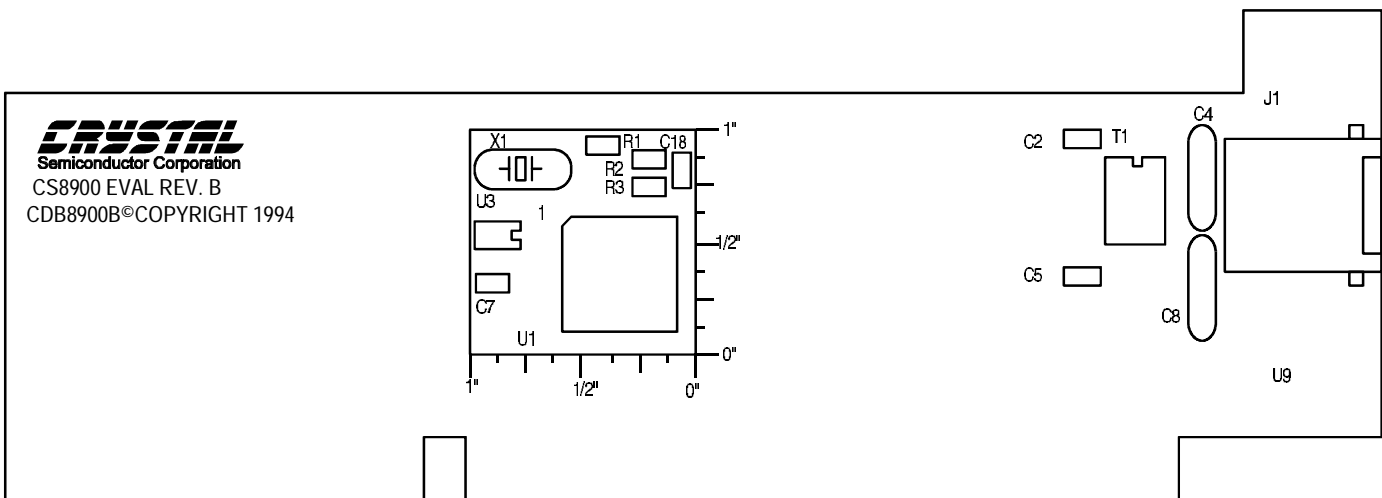

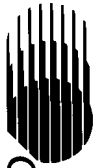

**CRYSTAL SEMICONDUCTOR CORPORATION
CS8900 EVAL BOARD REV. C
P/N CDB8900B**

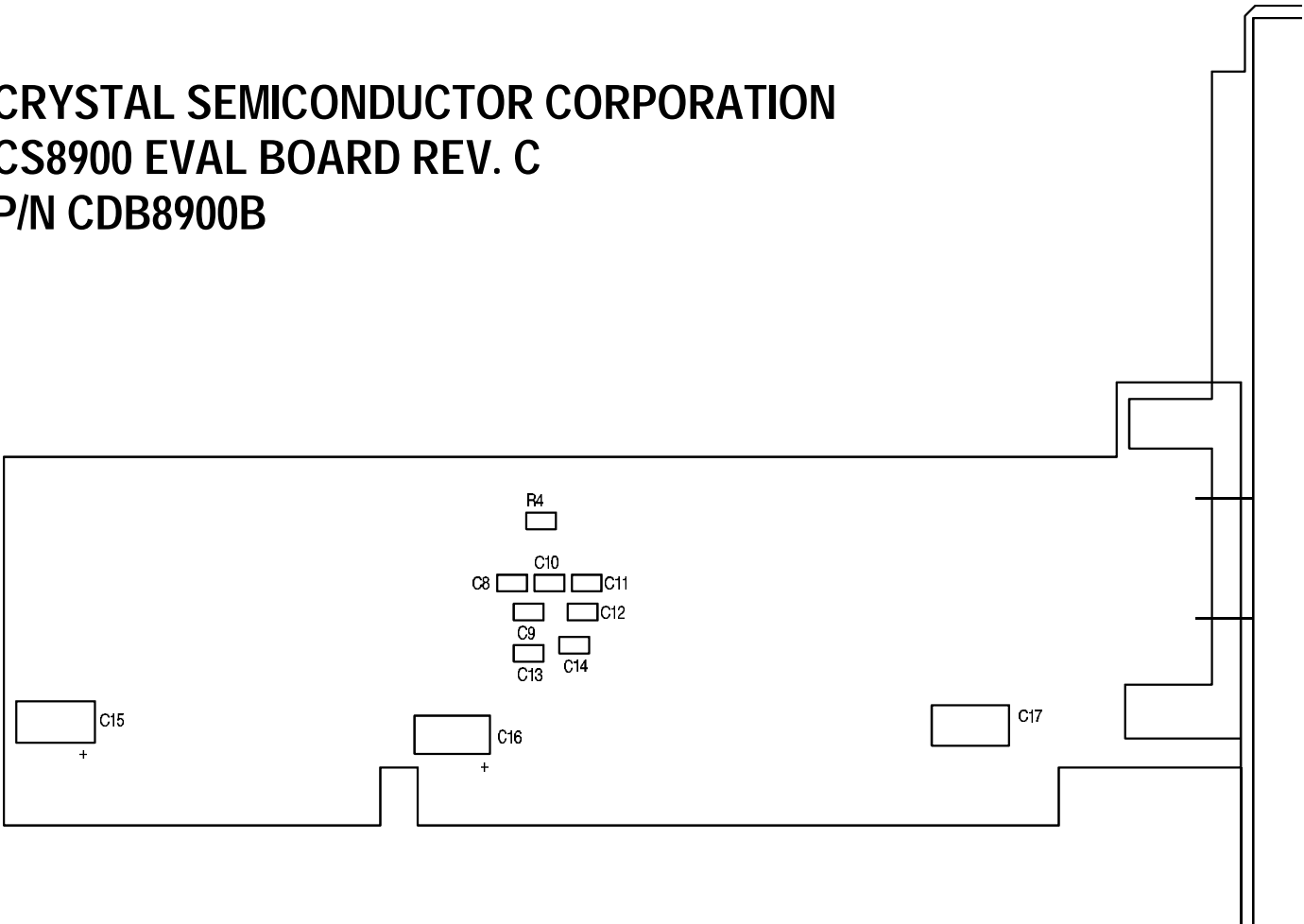

Figure 7. Placement of Components, Solder Side

PROM is not necessary for the CS8900A, and the CS8900A will respond to IO addresses 0300h through 030Fh after a reset.

Please refer to the CS8900A data sheet for information about programming the EEPROM. Please refer to “JUMPERLESS DESIGN” on page 45 of this document for information about EEPROM internal word assignments.

LEDs

Many embedded systems do not require LEDs for the Ethernet traffic. Therefore this reference design does not implement any LEDs. However, the CS8900A has direct drives for the three LEDs. Please refer to the data sheet for the CS8900A for a description of the LED functions available on the CS8900A.

10BASE-T Interface

The 10BASE-T interface for the CS8900A is straight forward. Please refer to Figure 8 (3.3V) and Figure 10 (5V) for connections and components of this circuit. Transmit and receive signal lines from the CS8900A are connected to an isola-

tion transformer at location T1. This isolation transformer has a 1:1 ratio between the primary and the secondary windings on the receive side. It has a $1:\sqrt{2}$ (1:1.414) ratio between the primary and the secondary windings for the transmit lines for 5V operation or a ratio of 1:2.5 for 3.3V operation. Resistor R1 provides termination for the receive lines. Resistors R2 and R3 are in series with the differential pair of transmit lines for impedance matching.

10BASE-2 and AUI Interfaces

As many embedded systems require only a 10BASE-T interface, this reference design implements only the 10BASE-T interface. However, should a user require a 10BASE-2 or AUI interface, the CS8900A provides a direct interface to the AUI. Please refer to “Low Cost Ethernet Combo Card Reference Design: CRD8900” on page 21 of this document for details about the AUI interface.

Logic Schematics

Figures 8, 9 and 10 detail the logic schematics for the various circuits used in the reference design.

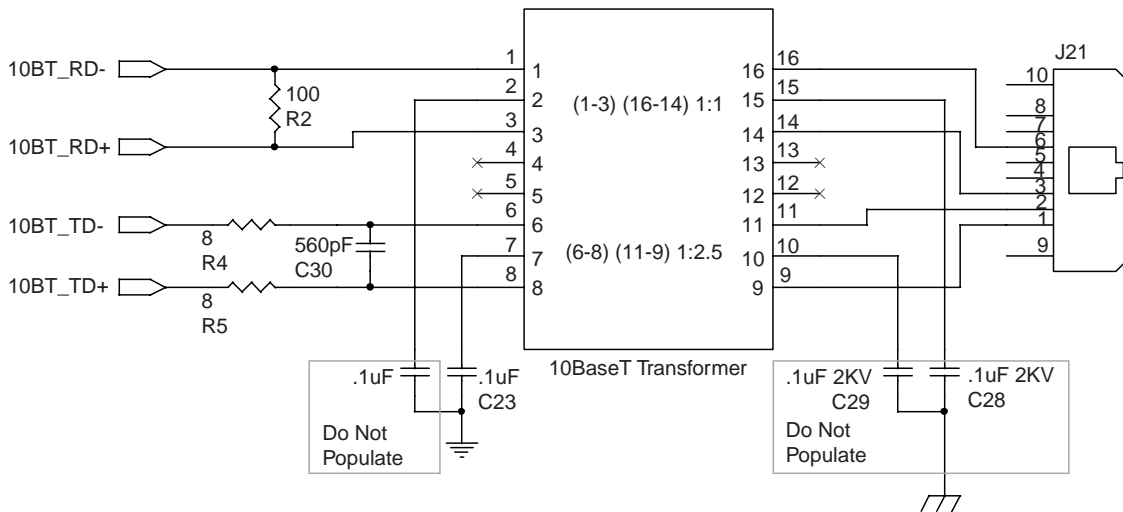
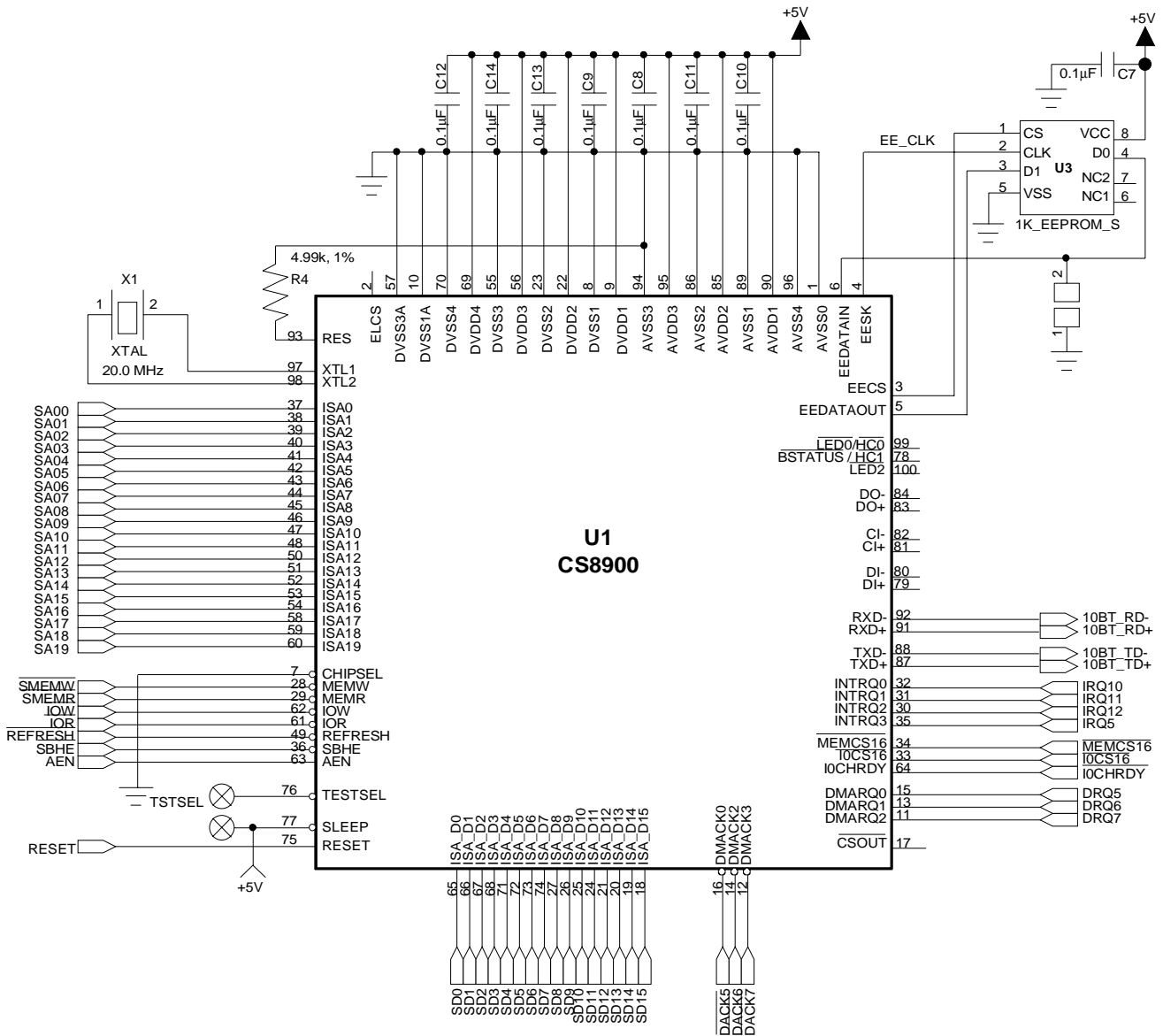

Figure 8. 10BASE-T Schematic 3.3V



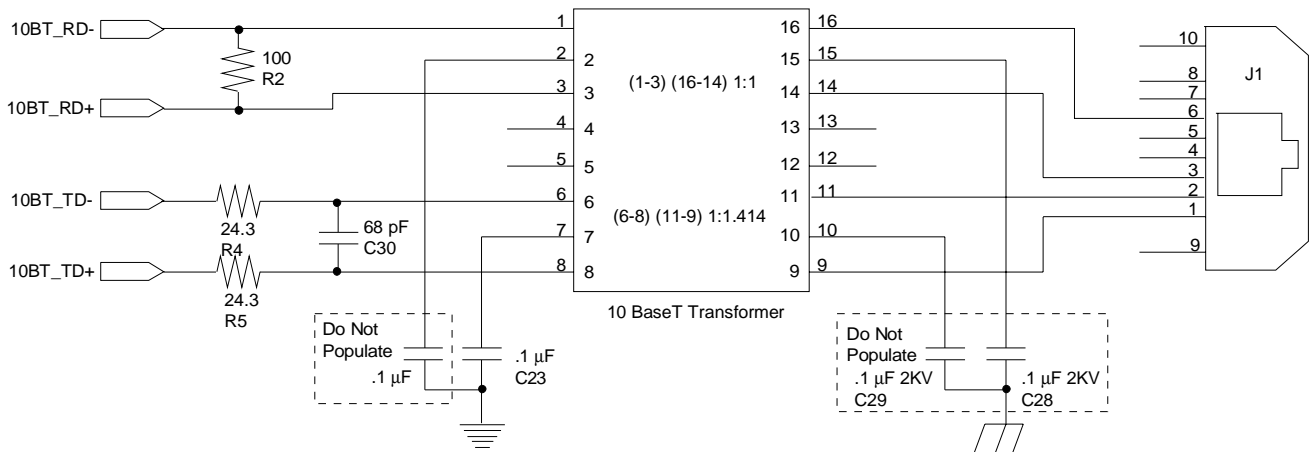

Figure 10. 10BASE-T Schematic 5V

Component Placement and Signal Routing

Please refer to “Layout Considerations for the CS8900A” on page 35 of this document for more details on the placement of components on the board. It is important to provide very clean and adequate +5 V and ground connections to the CS8900A.

Bill of Material

Table 1 has a list components that are typically used to assemble this adapter card. For most of the components, there are several alternative manufacturers.

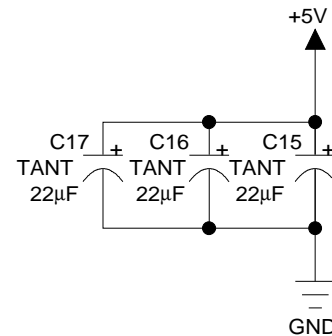

Figure 11. Decoupling Capacitors Schematic

Item	Reference #	Description	Quantity	Vendor	Part Number
1	C2, C5, C7..C14	Capacitor, 0.1 μF, X7R, SMT0805	10		
2	C15, C16, C17	Capacitor, 22 μF, SMT7343	3		
3	R2, R3	Resistor, 24.3, 1%, 1/8W, SMT0805	2		
4	R1	Resistor, 100, 1%, 1/8W, SMT0805	1		
5	R4	Resistor, 4.99K, 1%, SMT0805	1		
6*	X1	Crystal, 20.000 MHz	1	M-tron	ATS-49,20.000 MHz,18 pF
7	J1	Connector, RJ45, 8 pin	1	AMP	555164-1
8	T1	Transformer, 2, 1:1, 1:1.41	1	Valor	ST7011 (SOIC)
9	U1	ISA Ethernet Controller	1	Crystal	CS8900A
10*	U3	1K EEPROM	1	Microchip	93C46 (8 pin SOIC)

* Depending on system resources, these parts may not be needed.

Table 1. CS8900A Design Bill of Materials

LOW COST ETHERNET COMBO CARD REFERENCE DESIGN: CRD8900

This section describes the hardware design of a low-cost, two-layer, full-featured Ethernet solution intended for use in PC ISA-bus. The goal of this design is a high degree of application flexibility. Therefore, a number of features (BootPROM, AUI, 10BASE-2) are supported. An example of this circuit is included in this Technical Reference Manual.

General Description

The CS8900A ISA Ethernet controller is used in this low cost, high performance ISA Ethernet adapter card. This card has AUI, 10BASE-T and 10BASE-2 interfaces. The very high level of integration of the CS8900A results in a very low component count. This makes it possible to design a half height, two layered 16 bit ISA Ethernet adapter card. Since the analog filters are integrated on the CS8900A, the card may be compliant with FCC part 15 class (B) compliant.

Board Design

A recommended component placement is shown in Figure 12, and a recommended board schematics are shown in Figures 10 and 13 through 17.

Crystal Oscillator

The CS8900A, in the reference design, uses a 20.000 MHz crystal oscillator. Please note that the crystal must be placed very close to XTL1 and XTL2 pins of the CS8900A.

ISA Bus Interface

The ISA bus connections from the CS8900A can be easily routed to the ISA connector. If the pin-out of the CS8900A is placed as shown in Figure 12, there will be almost no cross-over of the ISA signals. It is also important to provide very clean and adequate +5 V and ground connections to the CS8900A.

External Decode Logic

The CS8900A can be accessed in both I/O and memory modes. The CS8900A internally decodes the SA[0:19] address lines for the lower 1 M of memory. The reference design uses an external decode logic to allow the card to also decode the upper 4 bits of the ISA address (LA[23:20]), thus allowing the CS8900A to reside anywhere in extended memory. This decode logic is implemented using a 16R4 PAL at location U4. This logic is configured by the CS8900A. The PAL then decodes the upper 4 bits of the ISA address. Please refer to “Addressing the CS8900A: I/O Mode, Memory Mode” on page 27 of this document for further information.

EEPROM

A 64 word (64 X16) EEPROM (location U3) is used in the reference design to interface with the CS8900A. This EEPROM holds the IEEE assigned Ethernet MAC (physical) address for the board. (see “Embedded Designs” on page 54) The EEPROM also holds other configuration information for the CS8900A. The last few bytes of the EEPROM are used to store information about the hardware configuration and software requirements.

Please refer to the CS8900A datasheet for information about programming the EEPROM. Please refer to “JUMPERLESS DESIGN” on page 45 of this document for information about EEPROM internal word assignment.

Socket for Optional Boot PROM

A socket is provided at location U6 for the optional Boot PROM. This Boot PROM is required in systems that require remote boot capability, for example diskless work stations. The 74LS245 data buffer at U7 is provided for the Boot PROM (See Figure 15). Inside the CS8900A there are registers that hold the Boot PROM base address (PacketPage base + 030h) and the Boot PROM address mask (PacketPage base + 034h). A 20 bit address

CRYSTAL SEMICONDUCTOR CORPORATION CS8900 COMBO EVAL BOARD REV. B P/N CDB8900B



Figure 12. Placement of Components

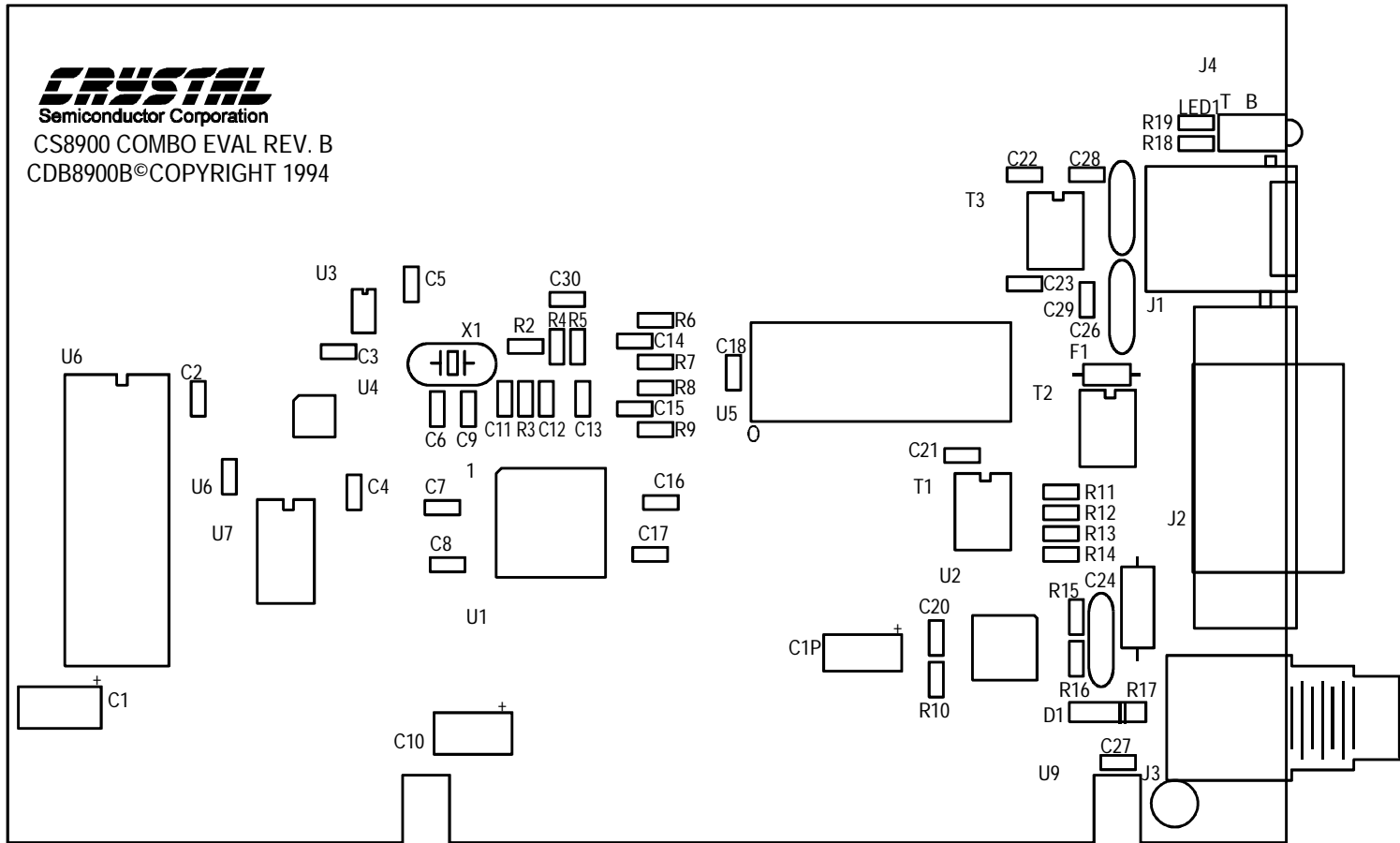

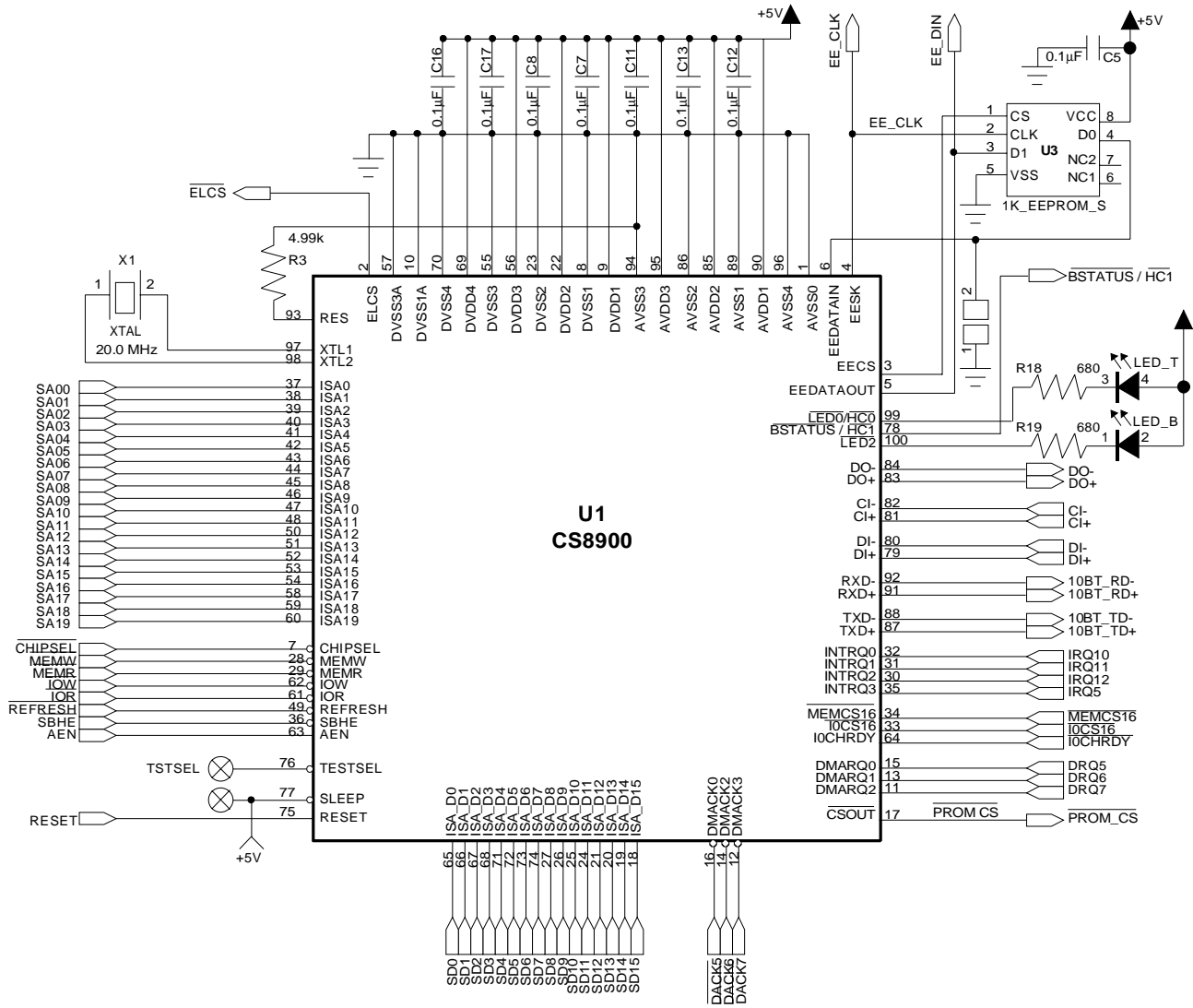

FIGURE 13. CS8900A Schematic (Combo Card Application)

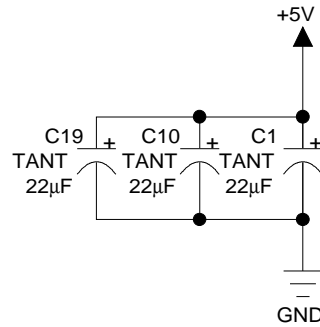

Figure 14. Power Supply Decoupling Schematic

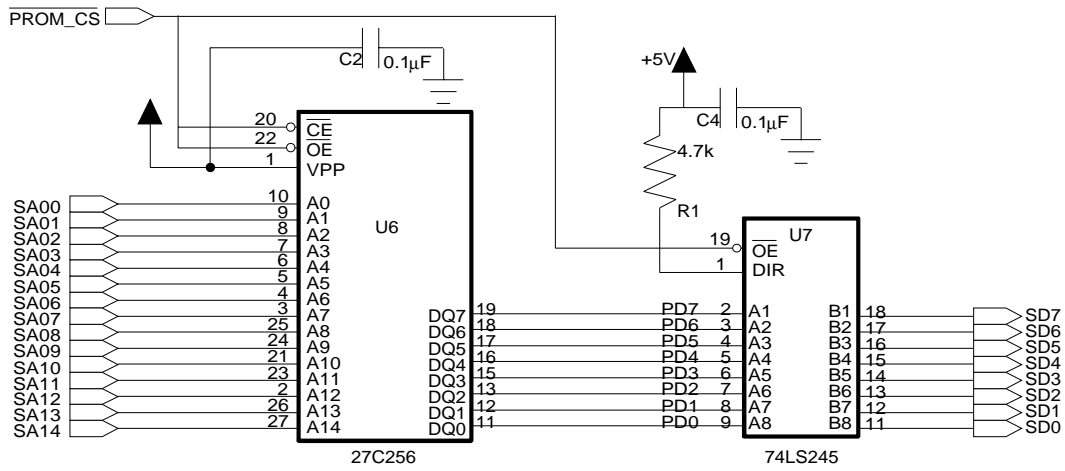
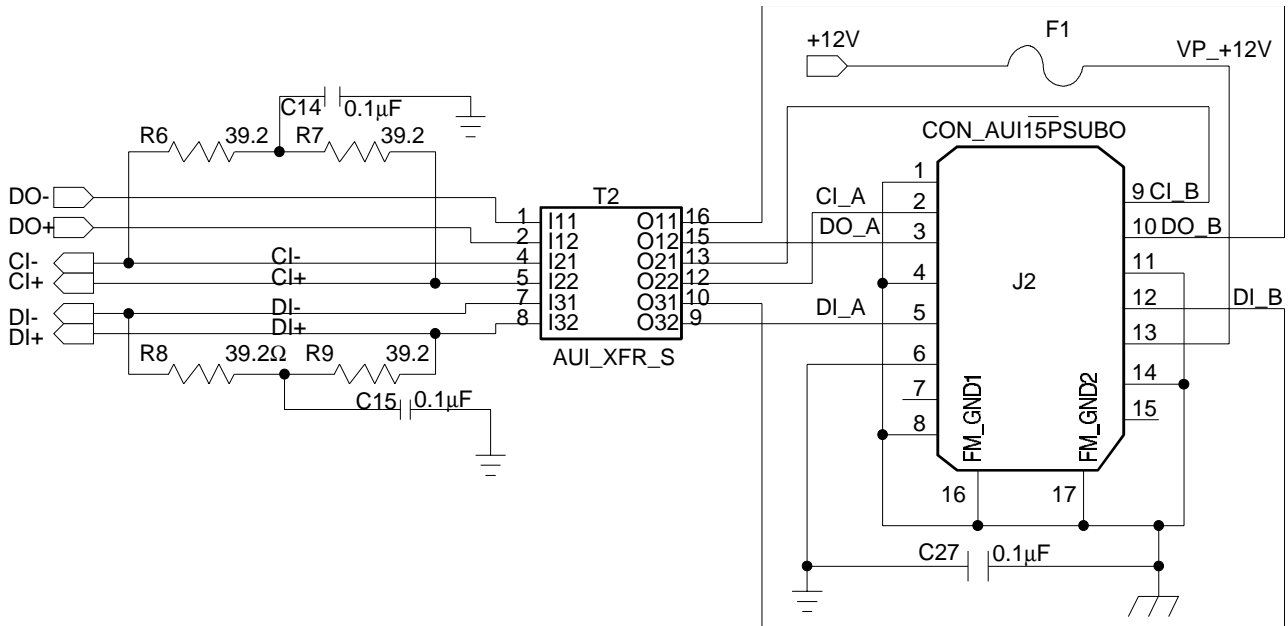
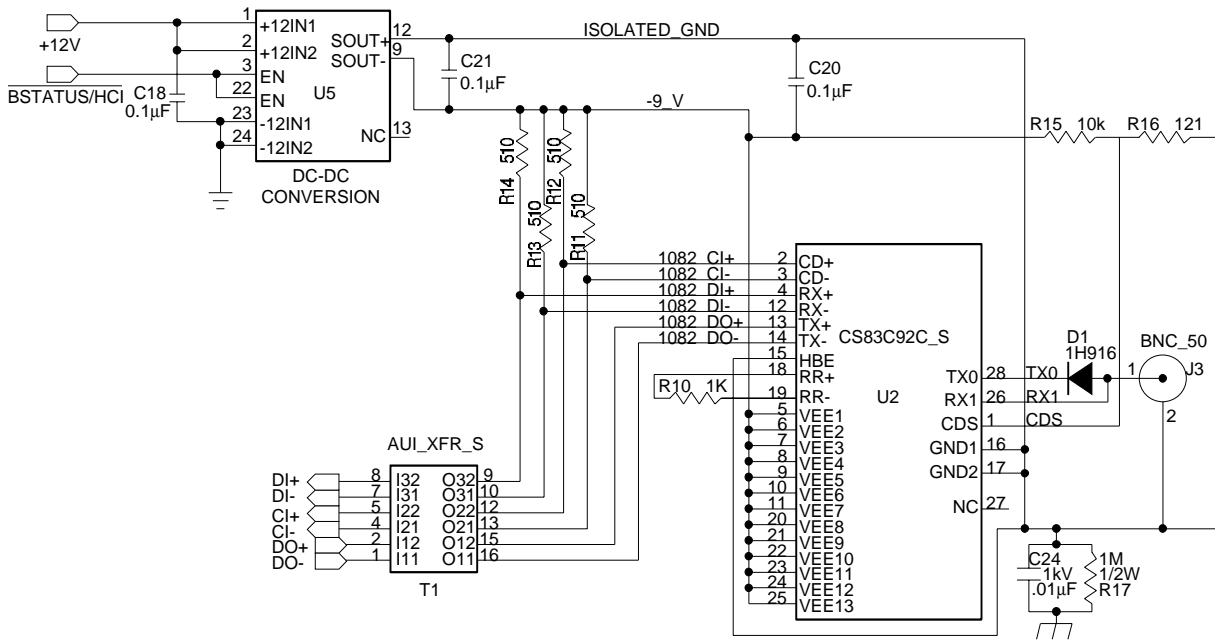
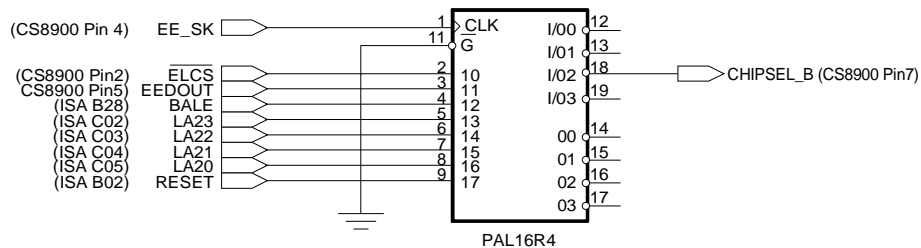

Figure 15. Boot PROM Schematic

Figure 16. AUI Schematic

Figure 17. 10BASE-2 Schematic

Figure 18. PAL Decode of LA[20-23]

loaded at the Boot PROM base address register indicates the starting location in host memory where the Boot PROM is mapped. The Boot PROM address mask indicates the size of the Boot PROM. The lower 12 bits of the mask are ignored and should be 000h. This limits the 434 Boot PROM size to increments of 4K bytes. The CS8900A will not generate an address decode for the Boot PROM until the Boot PROM base address register and the mask register are loaded. For example, say a 16K Boot PROM is used and it is to be located starting at address 0D0000h. Before this Boot PROM is accessed, load the following registers with the values shown in Table 2.

Register Word Offset PacketPage Base +	Hex value	Description
30h	0000h	Boot PROM Base address - low word
32h	000Dh	Boot PROM Base address - high word
34h	C000h	Boot PROM address mask - low word
36h	000Fh	Boot PROM address mask - high word

Table 2. BootPROM Descriptions Stored in CS8900A PacketPage

The address mask that will be used by the CS8900A is 0FC000h. The CS8900A will compare SA[19:14] with the value 0D0h. Whenever there is a match, it will assert the signal $\overline{\text{CSOUT}}$ to generate an address decode for the Boot PROM. In the reference design, the same signal is also used to enable the data buffer, 74LS245, at location U7.

LEDs

A pair of LEDs are provided in the reference design to indicate link OK and line active status. The pair of LEDs are packaged one on the top of the other at location LED1. The top LED is driven by the $\overline{\text{LIN-KLED}}$ pin while the bottom LED is driven by the LANLED pin of the CS8900A. The top LED lights

up when the CS8900A has the link pulse. The bottom LED lights up when the CS8900A transmits or receives a packet or senses a collision. The LEDs are directly driven by the CS8900A. Two 680 Ohm resistors limit the current flowing through the LED circuitry.

10BASE-T Interface

The 10BASE-T interface for the CS8900A is straight forward. Please refer to Figure 8 or 10 for connections and components of this circuit. Transmit and receive signal lines from the CS8900A are connected to an isolation transformer at location T3. For 5V operation this isolation transformer has a 1:1 ratio between the primary and the secondary windings on the receive side and $1:\sqrt{2}$ (1:1.41) ratio between the primary and secondary windings for the transmit lines. For 3.3V operation the receive side is 1:1 and the transmit side is 1:2.5. Resistor R2 provides termination for the receive lines. Resistors R4 and R5 are in series with the differential pair of transmit lines for impedance matching.

AUI Interface

Please refer to Figure 16 for connection of AUI signals to the CS8900A. The AUI lines from the 15-pin sub-D connector (location J2) are connected to the CS8900A through an isolation transformer at T2. This isolation transformer has three windings for three pairs of differential AUI signals: transmit, receive and collision. All three windings have a turns ratio of 1:1 between the primary and secondary windings. Circuitry consisting of R6, R7 and C14 provides impedance termination for the collision differential pair. Circuitry consisting of R8, R9 and C15 provides impedance termination for the receive differential pair. The +12 volt power going out to the AUI connector is safeguarded by the fuse at F1. The AUI interface at J2 can be used to connect external Media Access Units (MAU). These MAUs allow the AUI interfaced to be used to interface with 10BASE-5 or 10BASE-F.

10BASE-2 Interface

A 10BASE-2 transceiver IC, the 83C92C, is used to generate a 10BASE-2 interface for the reference design. Please refer to Figure 17 for details about the components and connection.

A 12 volt to -9 volt DC to DC voltage converter (location U5) is used to generate an isolated -9 volt supply for the 83C92C. The DC-DC converter used in the reference design has an enable pin. This enable pin is connected to the HC1 pin of the CS8900A. Usually the DC-DC converter is disabled when the 10BASE-2 interface is not used. This not only reduces power used by the adapter card but also eliminates any noise the 10BASE-2 circuitry can induce on the 10BASE-T or AUI interface that may be in use. This reference design uses a “low” enable DC-DC converter. That is, the DC-DC converter is enabled when the enable pin is logic low. However, the board can be built with a “high” enable DC-DC converter. In such a case, software that controls the enable and disable operations of the DC-DC converter should be modified.

An optional method is to use an integrated module that includes all the needed 10Base2 components. Contact Halo Electronics for information on their TnT integrated 10Base2 modules.

Logic Schematics

Figures 10 and 13 through 17 detail logic schematics for the various circuits used in the reference design.

Component Placement and Routing of Signals

Figure 12 shows the component placement used for the reference design. Figure 19 shows the routing of signals on the component side of the printed circuit board (PCB) while Figure 20 shows routing on the solder side. Please refer to “Layout Considerations for the CS8900A” on page 35 of this docu-

ment for an explanation and information about placement of components on the board.

Bill of Material

Table 3 contains a list of components that are typically used to assemble this adapter card. For most of the components, there are several alternative manufacturers.

Addressing the CS8900A: I/O Mode, Memory Mode

The CS8900A, integrated Ethernet controller, has 20 address pins that directly connect to SA[19:0] of the ISA bus. The CS8900A has an internal address comparator to compare the ISA address with its base address registers.

I/O Mode

In IO mode, the lower 16 bits of the ISA address are compared with the address stored in IO Base Address register (Packet Page base + 020h). When an address match occurs and one of the IO command ($\overline{\text{IOR}}$ or $\overline{\text{IOW}}$) lines is active, the CS8900A responds to that IO access. The lower 4 bits of address lines are ignored by the address comparator. This dictates that the CS8900A must always be at a 16 byte address boundary of the ISA IO address space. The pin $\overline{\text{CHIPSEL}}$ is ignored for an IO mode access.

After RESET the CS8900A responds to IO address 0300h. However, this condition can be modified with use of an EEPROM or by software. Immediately after a reset, the CS8900A reads the EEPROM interfaced to it. If the EEPROM has valid data (valid start data and correct checksum), it will read information stored in the EEPROM to initialize its own registers including the IO base address register. Please refer to the CS8900A datasheet for details about EEPROM configuration and programming. A CS8900A will always respond to valid IO address (even if its memory mode is enabled).

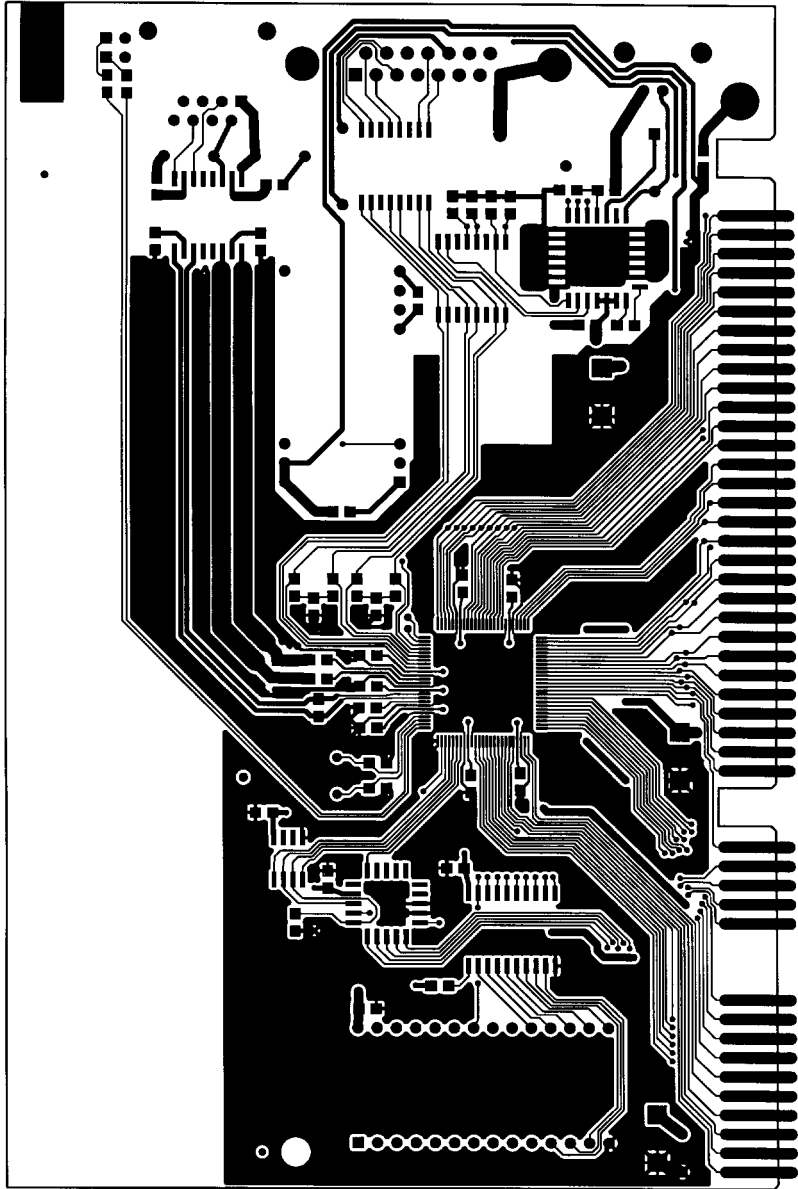

Figure 19. CRD8900 Top-Side Routing

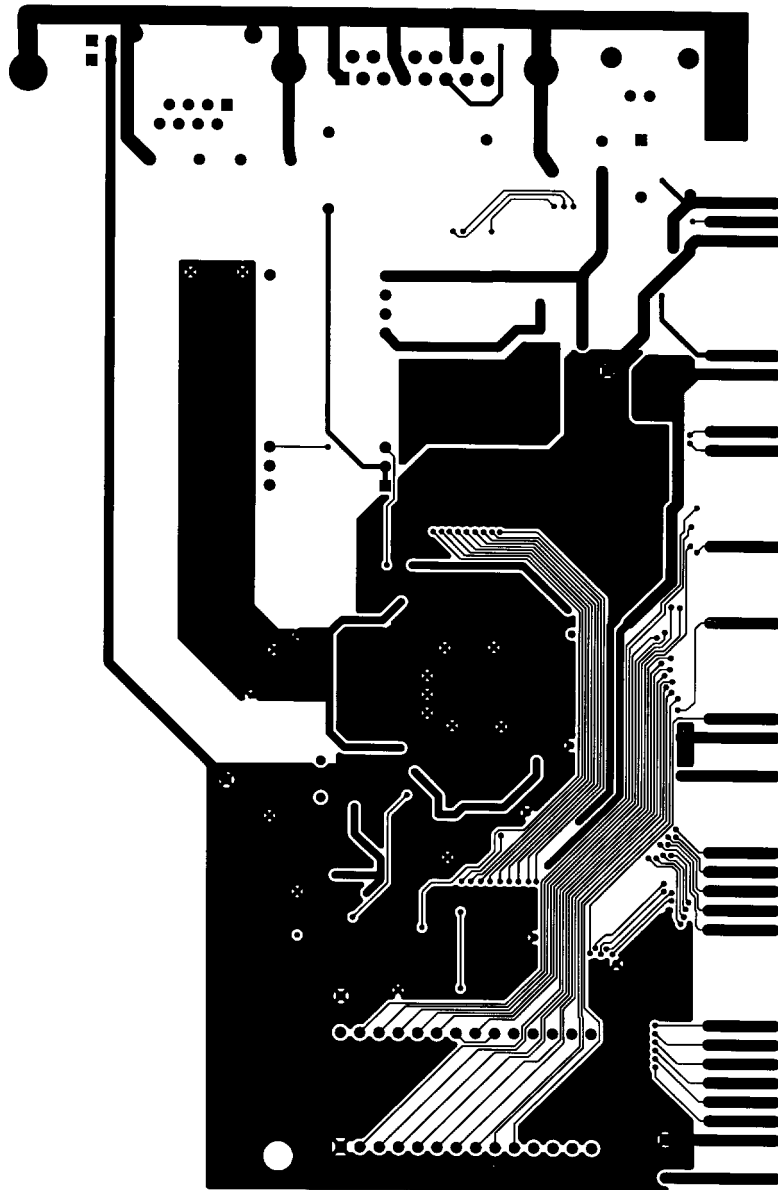

Figure 20. CRD8900 Bottom Side Routing

Item	Reference #	Description	Quantity	Vendor	Part Number
Base Configuration: I/O Mode with 10BASE-T Interface					
1	C5, C7, C8, C11..13, C16, C17, C22, C23, C27	Capacitor, 0.1 μ F, SMT0805, X7R	11		
2	C1, C10, C19	Capacitor, 22 μ F, SMT7343	3		
3	R3	Resistor, 4.99K, 1%, SMT0805	1		
4	R18, R19	Resistor, 681, 5%, 1/8W, SMT0805	2		
5	X1	Crystal, 20.000MHz, 18 pF	1	M-tron	ATS-49
6	J4	Board Bracket	1	Globe	G436
7	U1	ISA Ethernet Controller	1	Crystal	CS8900A
8	U3	1K EEPROM	1	Microchip	93C46
9	R4, R5	Resistor, 24.3, 1%, 1/8W, SMT0805	2		
10	R2	Resistor, 100, 1%, 1/8W, SMT0805	1		
11	C30	Capacitor, 68 pF, SMT0805	1		
12	T3	Transformer, 2, 1:1, 1:1.41	1	Valor	ST7010 (SOIC)
13	J1	Connector, RJ45, 8 pin	1	AMP	555164-1
Memory Mode Option					
1	C3	Capacitor, 0.1 μ F, SMT0805, X7R	1		
2	U4	PAL	1	AMD	PAL16R4B
Boot PROM Options					
1	C2, C4	Capacitor, 0.1 μ F, SMT0805, X7R	2		
2	R1	Resistor, 4.7K, 5%, 1/8W, SMT0805	1		
3	U6	32K X 8 EPROM Socket	1		
4	U7	Octal Transceiver	1	TI	74LS245 (SOIC)
AUI Option					
1	C14, C15	Capacitor, 0.1 μ F, SMT0805, X7R	2		
2	R6..R9	Resistor, 39.2, 1%, 1/8W, SMT0805	4		
3	F1	Fuse, 1A	1		
4	T2	Transformer, 3, 1:1, 100 μ H	1	Valor	ST7033 (SOIC)
5	J2	Connector, 15-pin sub-D	1	AMP	745782-1
6	J2	AUI Slide Latch	1	AMP	745583-5
10BASE2 Option					
1	C18, C20, C21	Capacitor, 0.1 μ F, SMT0805, X7R	3		
2	C24	Capacitor, 0.01 μ F, 1kV	1	NIC Components	NCD103M1KVZ5U
3	R11..R14	Resistor, 510, 1%, 1/8W, SMT0805	4		
4	R10	Resistor, 1K, 1%, 1/8W, SMT0805	1		
5	R17	Resistor, 1M, 10%, 1/2W, TH	1		
6	R15	Resistor, 10K, 1%, 1/8W, SMT0805	1		
7	R16	Resistor, 121, 1%, 1/8W, SMT0805	1		
8	D1	Diode	1		1N916
9	T1	Transformer, 3, 1:1, 100 μ H	1	Valor	ST7033 (SOIC)
10	U2	Ethernet Coax Transceiver	1		83C92C(PLCC)
11	U5	DC-DC Converter, 12V - 9V	1	Valor	PM7215
12	J3	Connector, BNC, 50 Ohm	1	AMP	227161-7
LED Option					
1	LED1	Bilevel LEDs	1	Ledtronics	21PCT110T4-G/Y

Table 3. CS8900A COMBO Card Reference Design Bill of Materials

Memory Mode

In the memory mode, there are two options where the CS8900A can be placed in the ISA memory address map, lower memory (below 1 Meg) or extended memory (above 1 Meg). The lower memory typically consists of the conventional memory (up to 640K) and upper memory (640K to 1 Meg. boundary). To access anything in extended memory, the processor (386 and above) is used in the “Enhanced Mode”.

The CS8900A will respond to IO addresses programmed in its IO Base Address Register (Packet Page Base + 020h) even if memory mode is enabled. To enable memory mode, first write a proper 20 bit value to Memory Base Address register at Packet page base + 02Ch & 02Eh. Then set MemoryE (bit 0Ah) in the Bus CTL register (Register 17) to one.

These operations can be performed either by doing writes using IO mode accesses or using an EEPROM as described in Sections 3.4 and 3.5 of the CS8900A datasheet. The CS8900A will respond to an ISA memory access, if the $\overline{\text{CHIPSEL}}$ pin is active (LOW), and the SA[19:0] match the value stored in Memory Base Address Registers. The lower 12 bits of the address lines are always ignored. This dictates that the CS8900A must always be placed at a 4K boundary in the ISA memory address space.

Lower Memory Mode

To use a CS8900A in the lower 1 Meg address space, $\overline{\text{SMEMRD}}$ and $\overline{\text{SMEMWR}}$ lines from the ISA bus are connected to $\overline{\text{MEMR}}$ and $\overline{\text{MEMW}}$ pins of CS8900A respectively. The $\overline{\text{SMEMRD}}$ and $\overline{\text{SMEMWR}}$ signals become active only for the lower 1 Meg of the ISA address space. The $\overline{\text{CHIPSEL}}$ pin of the CS8900A should be connected to ground.

Extended Memory Mode

The CS8900A can also be mapped in to the extended memory of a Personal Computer (PC) system. This provides flexibility and more options when several components are installed in a PC with CS8900A based network cards.

To address the CS8900A in extended memory mode, the processor is used in an enhanced mode. In an enhanced mode, 24 bits of ISA address lines are used for address generation. Since the CS8900A accepts 20 bits of address lines, an external address decoder circuit is required to decode the 4 upper address bits. The CS8900A has interface pins for external decoder circuit.

This arrangement makes provisions so that the CS8900A can be placed anywhere in the extended memory address map as long as it is at a 4K address boundary. The $\overline{\text{MEMR}}$ and $\overline{\text{MEMW}}$ signals of the ISA bus are active for any ISA memory space access, therefore, for extended memory mode operation, these signals are connected to the $\overline{\text{MEMR}}$ and $\overline{\text{MEMW}}$ pins of the CS8900A respectively.

The external address decoder circuit consists of a single and simple Programmable Array Logic like a 16R4 or GAL16V8. Please refer to the schematic shown in Figure 21 as an example of such a decoder circuit. The PAL16R4 has 4 registers Q[23:20]. These registers are programmed by the serial input via the inputs EESK (clock), $\overline{\text{ELCS}}$ (enable pin) and EEDataOut (serial data out). This decoder compares the 4 upper address bits, namely LA[23:20], with the internal programmable register, Q[23:20]. Before memory mode of the CS8900A is enabled, Q[23:20] must be initialized to a proper value.

In the design example, Q[23:20] form a left shift register. The $\overline{\text{ELCS}}$ pin of the CS8900A is used in conjunction with EESK and EEDataOut pins to shift in the data for Q[23:20] serially. To program a value, set the ELSEL bit (bit A in Packet Page base + 040h) to HIGH. Then the EEPROM inter-

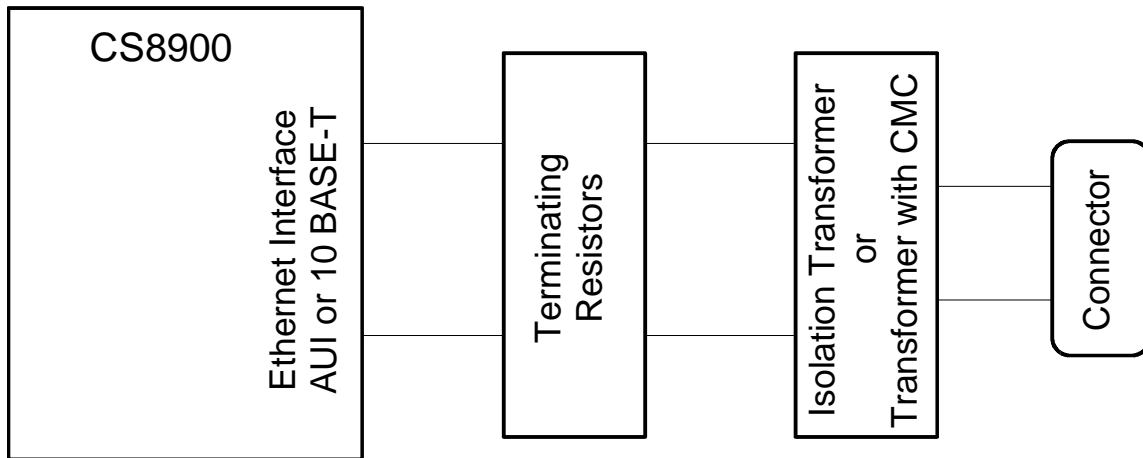

Figure 22. Typical CS8900A Ethernet Connection

face is used to generate the serial data stream on EEDataOut pin (serial data out) with the EESK (serial clock). Whenever ELSEL bit is set, \overline{ELCS} pin becomes active (LOW) instead of \overline{EECS} pin during the EEPROM operations. Since the \overline{EECS} pin remains inactive, the EEPROM that is interfaced to the CS8900A is not enabled.

For the PAL in the design example, one should use a "Program disable" EEPROM command. (Opcode 00000b). For example, if the CS8900A is to be placed at PC memory space of 0A00000h, that means the Q[23:20] should be 0Ah. To program the 16R4, write 040Ah at Packet Page Base + 040h. The instruction will take about 10 micro-seconds to execute.

The electrical connections required to use external logic are shown in Figure 21. At reset, the

CS8900A samples \overline{ELCS} pin and if it is not "LOW", it realizes presence of external address decode logic. The same reset signal also makes ADD_VALID inactive, and thus prevents a signal CHIPSEL_b from becoming active until Q[23:20] are initialized. When a host CPU writes to PacketPage base address + 040h to program values for Q[23:20], the CS8900A then shifts that data serially in to the PAL or GAL. This makes ADD_VALID signal active.

From this point onwards LA[23:20] are monitored whenever ALE is active (HIGH). When the decode logic finds a match, CHIPSEL_b signal is asserted. This signal remains asserted until ALE becomes active and the LA[23:20] do not match with Q[23:20]. The internal decoder of the CS8900A is active only when CHIPSEL_b is active (LOW).

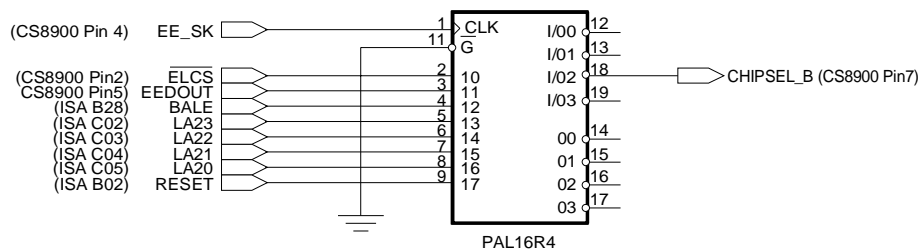

Figure 21. PAL Decode of LA[20-23]

Figure 23 shows a simple PALASMTM program for the 16R4 PAL that is used in the design shown in Figure 21.

```

;PALASM Design Description
;----- Declaration Segment -----
TITLE      High address decoder PATTERN
REVISION
AUTHOR     Deva Bodas
COMPANY    Crystal Semiconductor
DATE      04/01/1994

CHIP  _decoder  PAL16R4

;----- PIN Declarations -----
PIN  1      SCLK      ; Serial clock from the CS8900A pin 4 (EESK)
PIN  2      CS_EL_b   ; External Logic enable from the CS8900A pin 2 (ELCS*)
PIN  3      SDATA     ; Serial data in from the CS8900A pin 5 (EEDataOut)
PIN  4      ALE       ; Address latch enable from the ISA bus
PIN  5      LA23      ; Address 23
PIN  6      LA22      ; Address 22
PIN  7      LA21      ; Address 21
PIN  8      LA20      ; Address 20
PIN  9      RESET     ; ISA reset pin
PIN  11     OE        ; Output enable for the registered outputs
PIN  12     ADD_VALID COMB ; When high, Q[23:20] are programmed
PIN  13     EQUALH    COMB ; Upper 2 bits of address match
PIN  19     EQUALL    COMB ; Lower 2 bits of address match
PIN  18     CHIPSEL_b COMB ;  $\overline{\text{CHIPSEL}}$  to the CS8900A pin 7
PIN  14     Q20       ; REG
PIN  15     Q21       ; REG
PIN  16     Q22       ; REG
PIN  17     Q23       ; REG
;----- Boolean Equation Segment -----
EQUATIONS

; Serial shift register
;   When CS_EL_b is inactive (1), no change
;   When CS_EL_b is active (0), shift in data

```

```
Q20 :=      (Q20 * CS_EL_b) + (/CS_EL_b * SDATA)
Q21 :=      (Q21 * CS_EL_b) + (/CS_EL_b * Q20)
Q22 :=      (Q22 * CS_EL_b) + (/CS_EL_b * Q21)
Q23 :=      (Q23 * CS_EL_b) + (/CS_EL_b * Q22)

; Decode logic

EQUALL =    (Q20::*LA20) * (Q21::*LA21)    ; :: -> Exclusive NOR operator
EQUALH =    (Q22::*LA22) * (Q23::*LA23)
ADD_VALID =  /RESET * CS_EL_b * ADD_VALID    ; stay clear till any write
            + /RESET * /CS_EL_b              ; Set when address write
            + /RESET * ADD_VALID             ; Remain set until reset

CHIPSEL_b = RESET                            ; Get set at RESET
            + /ADD_VALID                      ; Remain set till address is valid
            + (/ALE * CHIPSEL_b)             ; Do not change when ALE is LOW
            + (ALE * /(EQUALL * EQUALH))     ; Clear during ALE if address matches

;      When ALE is active; CS_b goes active if EQUAL[1:2] are true
;      When ALE is inactive; previous state of CS_b is latched.
```

Figure 23. PAL Program

Layout Considerations for the CS8900A

The CS8900A is a mixed signal device having digital and analog circuits for an Ethernet communication. While doing the PCB layout and signal connections, it is important to take the following precautions:

- Provide a low inductive path to reduce power and ground connection noise.
- Provide proper impedance matching especially to the Ethernet analog signals.
- Provide low inductive path, wider and short traces, for all analog signals.

It is important that a PCB designer follow suggestions made in this document for proper and reliable operation of the CS8900A. These guidelines will also benefit the design with good EMI test results.

General Guidelines

Figure 24 shows component placement for an ISA COMBO Ethernet adapter card using a CS8900A. The placement of the CS8900A should be such that the routes of the analog signals and the digital signals are not intermixing. No signal should route beneath the CS8900A on any plane.

Power Supply Connections

The CS8900A has 3 analog and 4 digital power pin pairs (Vcc and GND). Additional ground connections are provided. Each power pin pair should be connected to a 0.1 μ F bypass capacitor. Connect the extra ground pins directly the ground plane.

Two Layered Printed Circuit Board (PCB)

A two layered PCB has signal traces on the component and solder side of the PCB. Fill unused areas with copper planes. Typically, planes on the component side of the PCB are connected to ground and those on the solder side are connected to VCC or +5 volts.

Provide each pair of power pin with a 0.1 μ F bypass capacitor. Place each bypass capacitor as close as possible to the corresponding power pin pair. Con-

nect the capacitor to the pads of the power pins by short, wide traces, the other end of these traces should be connected to VCC and GND planes. Figure 19 and Figure 20 illustrate ground and power (Vcc) plane connections, respectively.

Multi-layered Printed Circuit Board

A multi-layered printed circuit board (PCB) typically has separate ground and power (Vcc) planes. Multi-layered PCBs are required when the component and trace density is high. Often discrete components like resistors and capacitors are placed on the solder side of a printed circuit board.

For a multi-layer PCB with all components on one side of the board, follow the power connection guide lines as explained in “Two Layered Printed Circuit Board (PCB)” on page 35. Instead of connecting the ground and Vcc to the copper fills on the component and solder side of the board, connect them to the internal ground and Vcc planes. Figures 27 through 30 show the four layers of the four-layer card.

For a multi-layered board the discrete components are to be placed on the solder side of the PCB, bypass capacitors for the CS8900A can be placed on the solder side of the PCB. Each bypass capacitor should be placed beneath the CS8900A and closest to its corresponding power pin pair. Figures 31 and 32 illustrate the placement and routing of one bypass capacitor.

Routing of the Digital Signals

Most of the digital signals from the CS8900A go to the ISA bus connector. Route these signals directly to the connector. Isolate the digital signals from analog signals.

Routing of the Analog Signals

Routing of the clock signals: Place the 20.000 MHz crystal within one inch of XTL1 (pin #97) and XTL2 (pin #98) pins of the CS8900A.

CRYSTAL SEMICONDUCTOR CORPORATION CS8900 COMBO EVAL BOARD REV. B P/N CDB8900B

Figure 24. General placement on an ISA adapter card

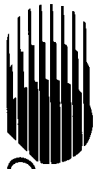
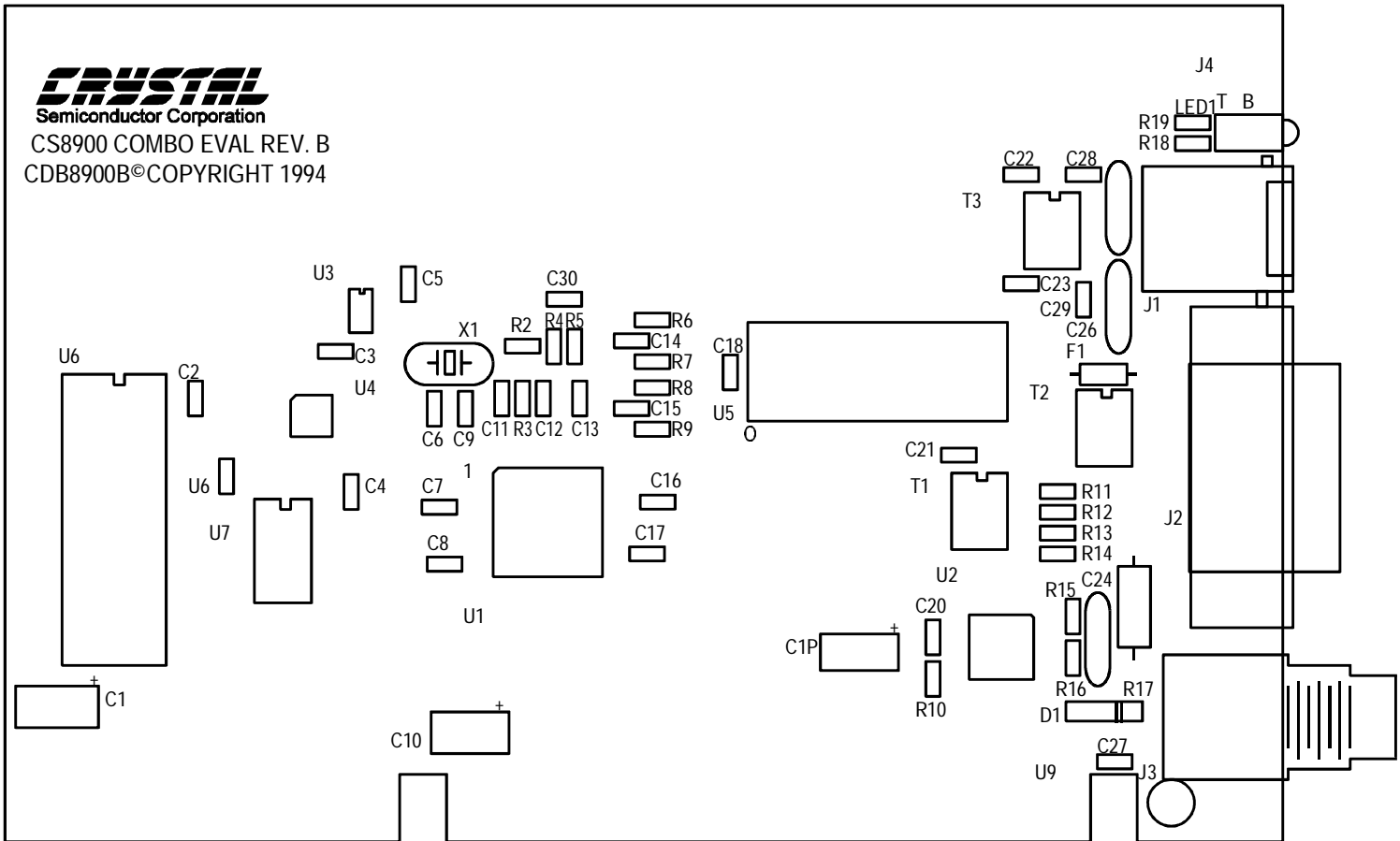

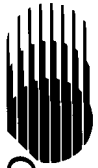

CRYSTAL SEMICONDUCTOR CORPORATION CS8900 EVAL BOARD REV. B P/N CDB8900B

Figure 25. Placement of Components, Top Side

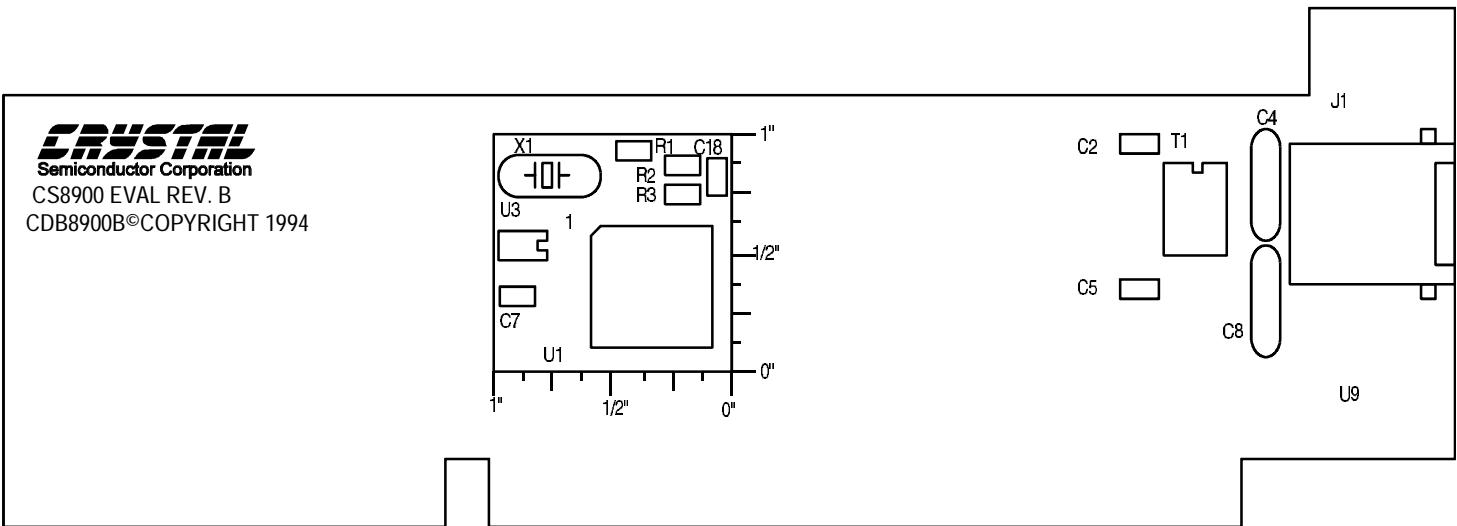

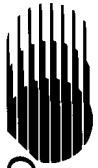

CRYSTAL SEMICONDUCTOR CORPORATION
CS8900 EVAL BOARD REV. C
P/N CDB8900B

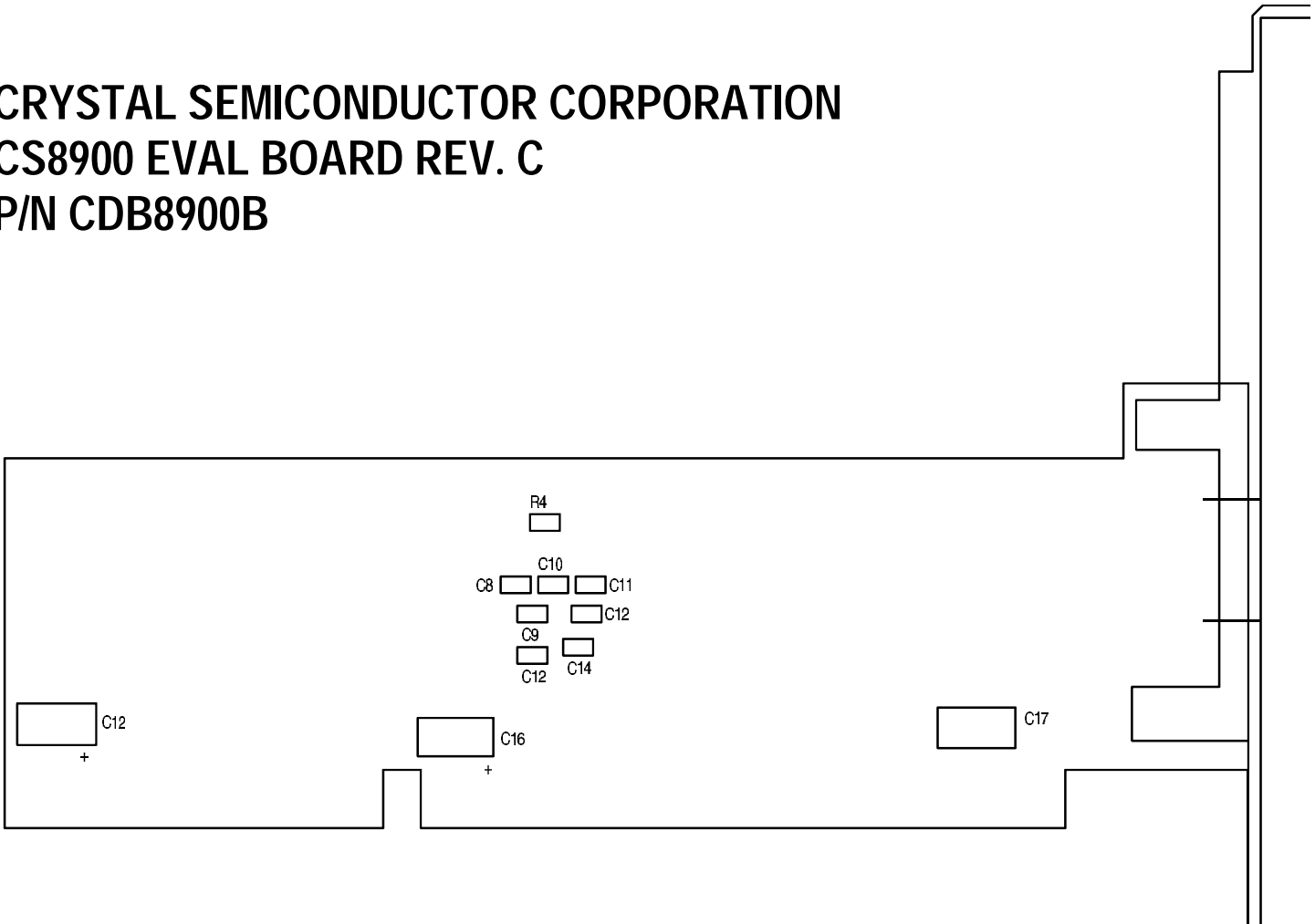

Figure 26. Placement of Components, Solder Side

CRYSTAL SEMICONDUCTOR CORPORATION
CS8900 EVAL BOARD REV.B
P/N CDB8900B

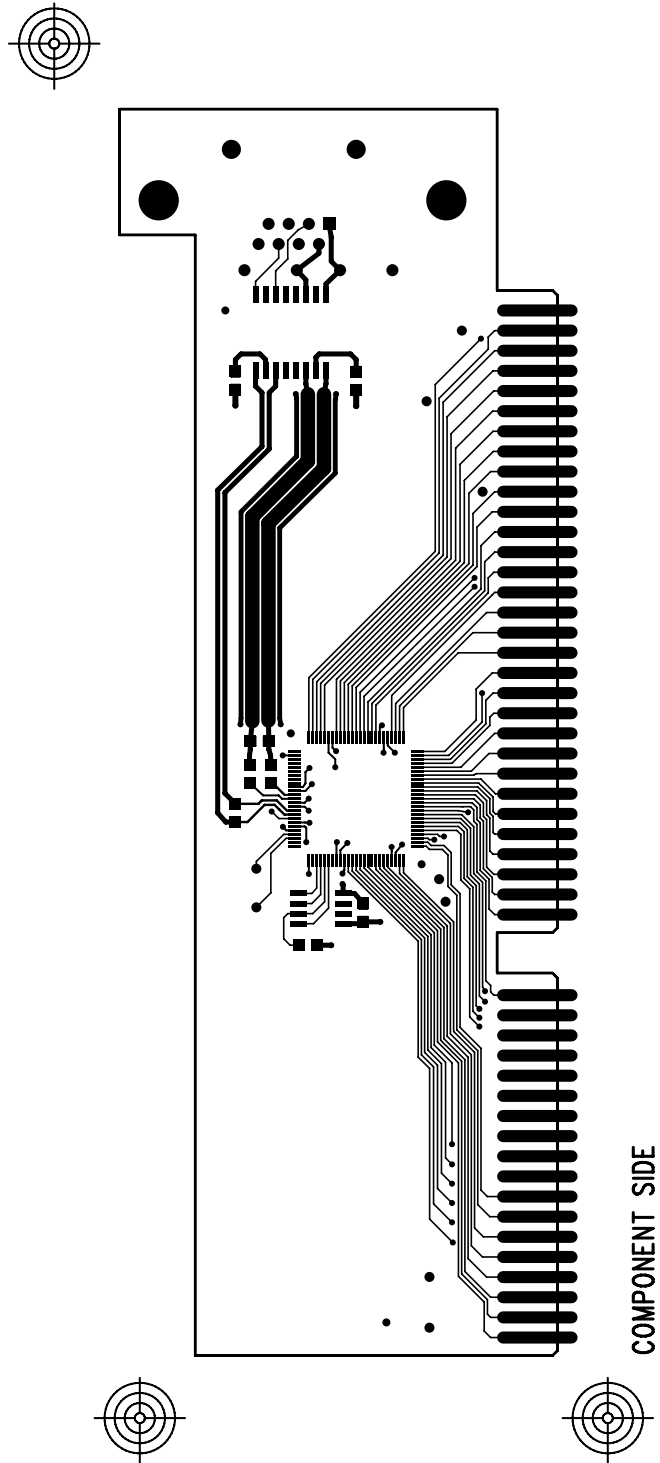

Figure 27. Component (top) side of four-layer board

CRYSTAL SEMICONDUCTOR CORPORATION
CS8900 EVAL BOARD REV.B
P/N CDB8900B

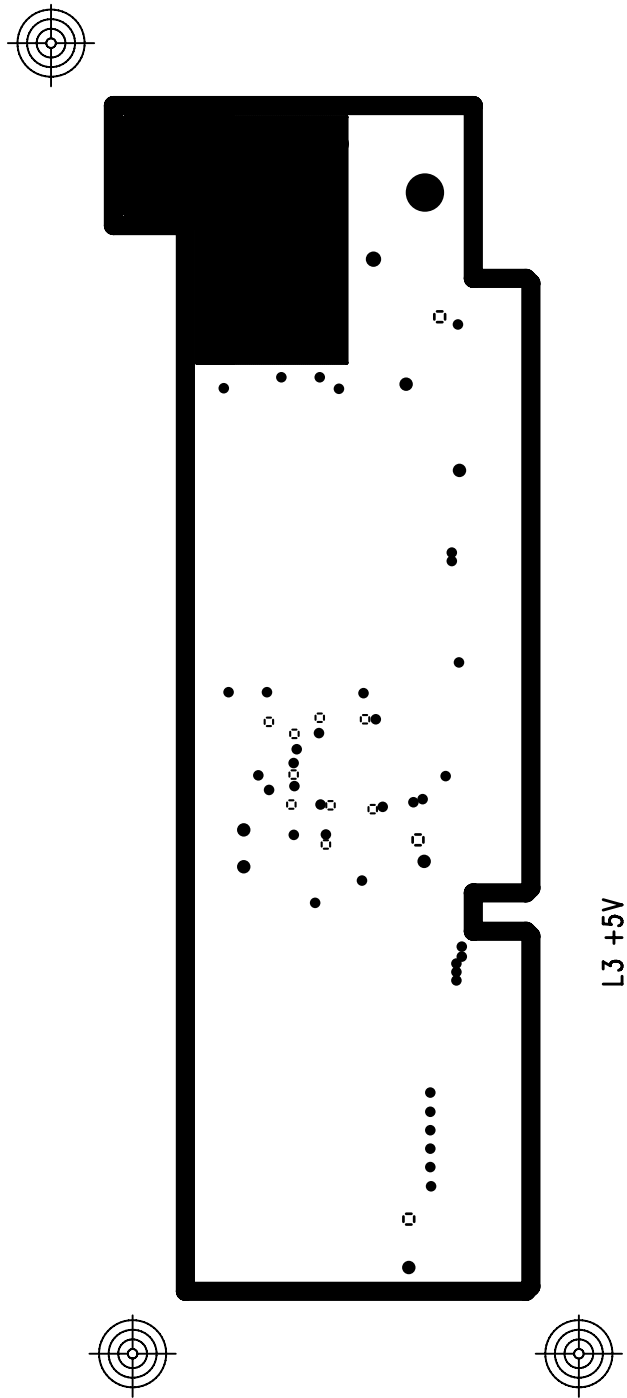

Figure 28. +5V Plane of four-layer board

CRYSTAL SEMICONDUCTOR CORPORATION
CS8900 EVAL BOARD REV.B
P/N CDB8900B

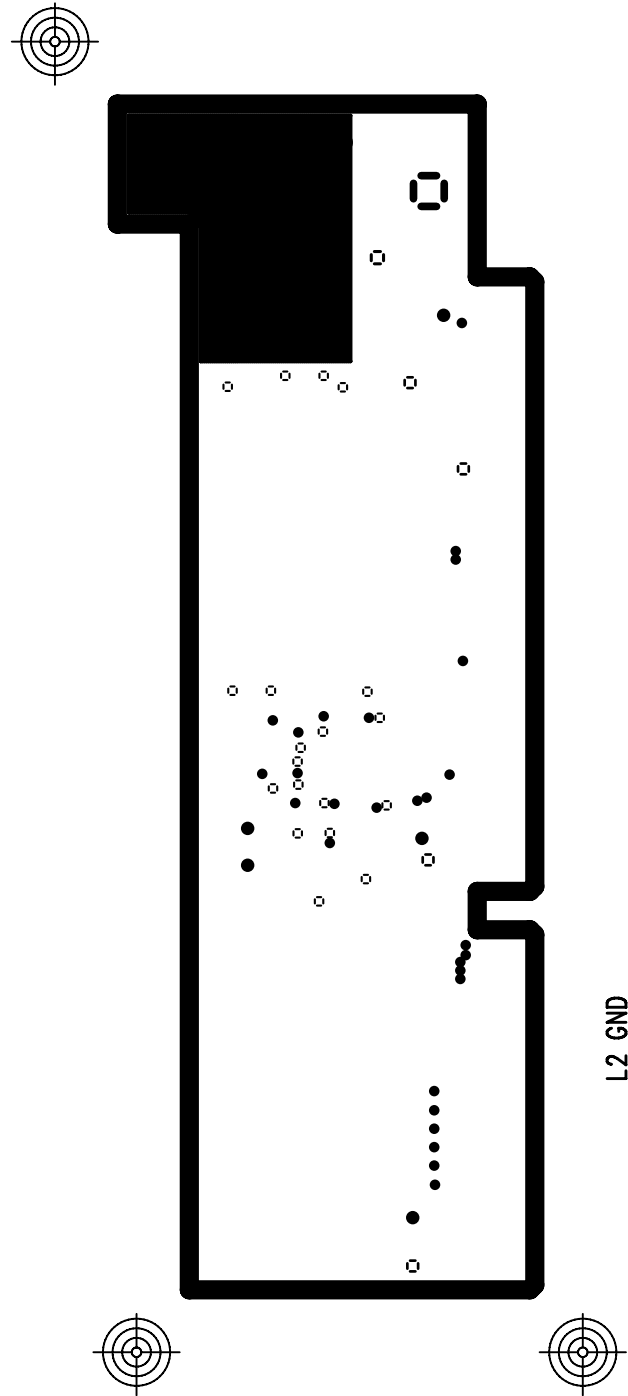

Figure 29. Ground Plane of four-layer board

CRYSTAL SEMICONDUCTOR CORPORATION
CS8900 EVAL BOARD REV.B
P/N CDB8900B



Figure 30. Solder side (bottom) of four-layer board



Figure 31. Placement of Decoupling Capacitor (Bottom side, under CS8900A)

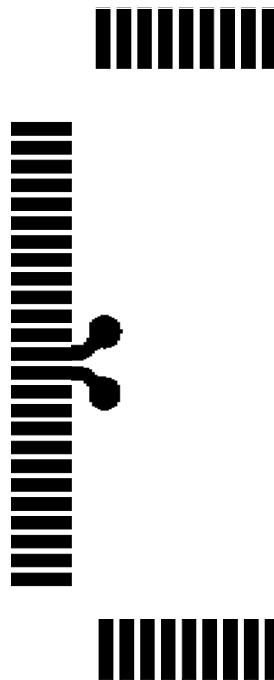

Figure 32. Routing of Decoupling Capacitor (Top side, component side)

The 20.000 MHz crystal traces should be short, have no via, and run on the component side.

Biasing resistor at RES pin of the CS8900A: A 4.99 K Ω resistor is connected between pins RES (pin #93) and AVSS3 (pin #94) of the CS8900A. This resistor biases internal analog circuits of the CS8900A, and should be placed as close as possible to RES pin (pin #93) of the CS8900A.

Routing of the 10BASE-T signals: Four signals are used for 10BASE-T communication, two dif-

ferential transmit signals and two differential receive signals. An isolation transformer is placed between the transmit and receive traces and a RJ-45 (modular phone jack) connector. The isolation transformer should be placed as close as possible to the RJ-45 connector. Both transmit and receive signal traces should be routed so they are parallel and of equal length. The signal traces should be on the component side and should have direct and short paths. The widths of the receive signal traces should at least be 25 mil. while widths of the trans-

mit signal traces should be at least 100 mil. This will provide a good impedance matching for the transmit and receive circuitry inside the CS8900A. A ground trace should be run parallel to the transmit traces. Also, a ground plane should run underneath the transmit and receive traces on the solder side of a two layered PCB. Please refer to the Figures 33 and 34 for illustration of the above guide lines.

Routing of the AUI signals: The CS8900A has three pairs of differential signals connecting it to an Auxiliary Unit Interface (AUI). An isolation transformer separates the three signal pairs and the AUI connector (a 15 pin sub-D connector). The isolation transformer should be placed as close as possible to the AUI connector. Signal traces of each differential pair should be in parallel with equal length and impedance. Thus minimizing differential noise due to impedance mismatch. Place the AUI signal traces on the component side.

RECOMMENDED MAGNETICS FOR THE CS8900A

The CS8900A is has two types of Ethernet interfaces 10BASE-T and AUI. For both the interfaces, analog filters are on the chip. The Figures 10 and 16 show typical connection required for these interfaces.

For an AUI interface, an isolation transformer without a common mode choke (CMC) is used.

For the 10BASE-T interface, choice between isolation transformer and isolation transformer with a common mode choke (CMC) depends on the common mode noise that exists on the 10BASE-T lines in a particular system. A common mode choke reduces common mode noise emitted by the 10BASE-T lines. A CMC may be required in certain applications to meet EMI requirements and to meet 10BASE-T common mode output voltage noise specification. The physical dimensions of the isolation transformer and the isolation transformer with a CMC are the same. Both are typically avail-

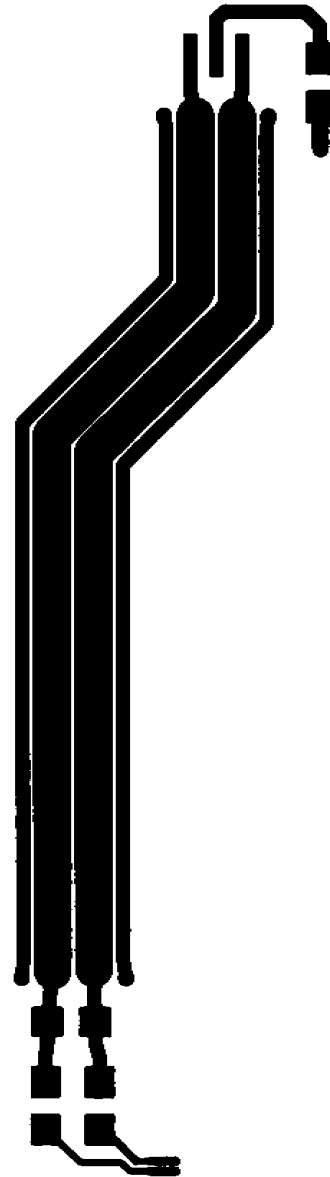

Figure 33. 10BASE-T Transit Layout Details



Figure 34. 10BASE-T Receive Layout Details

able in a 16 pin DIP or 16 pin SOIC package. See tables 4 and 5 for recommended part numbers.

JUMPERLESS DESIGN

Using the CS8900A, both add-in adapters and motherboard solutions can be implemented without hardware jumpers or switches. The CS8900A and media access control (MAC) device drivers obtain configuration information directly from nonvolatile memory. For add-in ISA adapters, a serial EEPROM will be connected directly to the CS8900A via the serial interface. Motherboard solutions may use an on-board serial EEPROM or other nonvolatile memory such as a flash EPROM-based BIOS. Typically, a separate software utility is used to initially store and modify the configuration information.

Serial EEPROM

Two types of configuration information is stored in the EEPROM: configuration information automatically loaded into the CS8900A after each reset and driver configuration information used by the MAC driver.

Reset Configuration Block

After each reset (except EEPROM reset) the CS8900A checks to see if an EEPROM is connected. If an EEPROM is present, the CS8900A automatically loads the first block of data stored in the EEPROM into its internal registers. This block of data is referred to as the Reset Configuration Block. It is used to initialize the CS8900A after each reset.

Software resets may occur frequently and performance will be enhanced if chip re-initialization takes as little time as possible. Therefore, since EEPROM readout takes approximately 25 μ sec. per word, the length of the Reset Configuration Block should be kept to a minimum.

The MAC drivers provided by Cirrus will retain much of the adapter's configuration across soft-

Vendor name	Description	Through-hole	Surface-mount
Halo Electronics	Isolation transformer, 100 μ H	TD01-1006K	TG01-1006N
Pulse Engineering	Isolation transformer, 100 μ H	PE-64503	PE-65728
Valor Electronics	Isolation transformer, 100 μ H	LT6033	ST7033

Table 4. Partial List of Recommended AUI Transformers

Vendor name	Description	Through-hole	Surface-mount
Halo Electronics	Transformer 1:1::1:1.41	TD42-2006Q	TG42-1406N1
	Transformer with CMC	TD43-2006K	TG43-1406N
	Industrial temperature 1:1::1:1.41		TG42-2006N1
	Industrial temperature 1:1::1:1.41 with CMC		TG43-2006N
	3.3V Commercial/Industrial temperature 1:1::1:2.5		TG92-2006N1
	3.3V Commercial/Industrial temperature with CMC		TG41-2006N
	For PCMCIA versions contact Halo		
Pulse Engineering	Isolation transformer 1:1::1:1.41	PE-65994	PE-65745
	Transformer with CMC	PE-65998	PE-65746
	3.3V Transformer 1:1::1:2.5 with CMC		E2023
	3.3V Industrial temperature 1:1::1:2.5 with CMC		EX2024
Valor Electronics	Isolation transformer 1:1::1:1.41	PT4069	ST7011
	Transformer with CMC	PT4068	ST7010

Table 5. Partial list of Recommended 10BASE-T Transformers

Company and Address	Telephone	FAX
Halo Electronics, Inc. Redwood City, CA 94063 http://www.haloelectronics.com	(415)-568-5800	(415)-568-6161
Pulse Engineering PO Box 12235 San Diego, CA 92112 http://www.pulseeng.com	(619)-674-8100	(619)-674-8262
Valor Electronics (merged with Pulse) 9715 Business Park Avenue, San Diego, CA 92131 http://www.pulseeng.com	(619)-537-2500	(619)-537-2525

Table 6. Transformer Vendors

ware resets. Therefore, the only information required in the Reset Configuration Block when used with Cirrus-provided drivers will be the IO base address (if different than the default 300h) and Boot PROM configuration when a Boot PROM is used. Table 7 shows an example of a typical Reset Configuration Block for an adapter with a Boot PROM.

The first word of the block indicates the type of EE-PROM in use and the length of the Reset Configuration Block (the number of bytes loaded into the CS8900A after reset). The last word of the block contains an 8-bit checksum (in the high byte) of all the bytes in the block. Refer to the *CS8900A Data*

Sheet for additional information on the operation of the EEPROM.

Addr	Word	Description
00h	A110h	Sequential EEPROM, 16 bytes follow
01h	0020h	1 word into PP_020 (IO Base Addr)
02h	0210h	IO Base Address = 210h
03h	3030h	4 words beginning at PP_030
04h	8000h	Boot PROM base at C8000h
05h	000Ch	
06h	C000h	Boot PROM mask of FC000h (16K)
07h	000Fh	
08h	1600h	Checksum

Table 7. EEPROM Reset Configuration Block

Driver Configuration Information

The CS8900A supports random access to 16-bit words in the EEPROM through software control. Therefore, in addition to the configuration data stored in the Reset Configuration Block automatically loaded by the CS8900A after each reset, addi-

tional configuration information can be stored in the EEPROM and accessed by the MAC driver.

Typically, this additional configuration information includes the unique IEEE physical address for the adapter. It may also contain device configuration information used by the MAC driver such as hardware version, media capabilities, and bus configuration (IRQ, DMA, and memory).

Format of Driver Configuration Block

Table 8 defines the format of the block of configuration information (referred to as the Driver Configuration Block) required for use with MAC drivers provided by Cirrus. Cirrus recommends all fields be initialized to their default values before shipping the adapter. Default values for each field are indicated in the following sections. All reserved fields should be set to zero.

Note: The Driver Configuration Block must start at EEPROM word address 1Ch to ensure compatibility with MAC drivers supplied by Cirrus.

Addr.	Description	Bit(s)	Function
1Ch	IA bits[39-32], bits[47-40]	15-0	IEEE individual node address
1Dh	IA bits[23-16], bits[31-24]	15-0	IEEE individual node address
1Eh	IA bits[7-0], bits[15-8]	15-0	IEEE individual node address
1Fh	ISA Configuration Flags		
	Memory Mode Flag	15	0 = memory mode disabled, 1 = memory mode enabled
	Boot PROM Flag	14	0 = no Boot PROM, 1 = Boot PROM installed
	StreamTransfer	13	0 = disabled, 1 = enabled
	DMA Burst	12	0 = disabled, 1 = enabled
	RxDMA Only	11	0 = disabled, 1 = enabled
	Auto RxDMA	10	0 = disabled, 1 = enabled
	DMA Buffer Size	9	0 = 16K, 1 = 64K
	IOCHRDY Enable	8	0 = disabled, 1 = enabled
	Use SA	7	0 = disabled, 1 = enabled
	DMA Channel	6-4	0 = DRQ5, 1 = DRQ6, 2 = DRQ7, 3 = DMA Disable
	IRQ	3-0	0 = IRQ10, 1 = IRQ11, 2 = IRQ12, 3 = IRQ5
20h	PacketPage Mem Base	15-4	12 MSBs of 24-bit address (lower 12 bits assumed = 0)
	Reserved	3-0	Reserved for future use, set to 0
21h	Boot PROM Base	15-4	12 MSBs of 24-bit address (lower 12 bits assumed = 0)
	Reserved	3-0	Reserved for future use, set to 0
22h	Boot PROM Mask	15-4	12 MSBs of 24-bit addr mask (lower 12 bits assumed = 0)
	Reserved	3-0	Reserved for future use, set to 0

Table 8. EEPROM Driver Configuration Block

Addr.	Description	Bit(s)	Function
23h	Transmission Control		
	HDX/FDX	15	0 = Half-Duplex, 1 = Full-Duplex
	Reserved	14-7	Reserved for future use, set to 0
	Ignore Missing Media	6	0 = Media required for driver to load, 1 = media not required
	Reserved	5-0	Reserved for future use, set to 0
24h	Adapter Configuration		
	Ext. 10B-2 Cable Circuitry	15	0 = Not Present, 1 = Present
	LoRx Squelch	14	0 = LoRx Squelch disabled, 1 = LoRx Squelch enabled
	PolarityDis	13	0 = polarity correction enabled, 1 = pol. correction disabled
24h	Adapter Configuration		(Continued)
	Optimization Flags	12-11	00 = Server, 01 = DOS Client, 10 = Multi-OS Client
	Reserved	10-8	Reserved for future use, set to 0
	DC/DC Converter Polarity	7	0 = Low enable, 1 = High enable
	Media Type in Use	6-5	0 = Auto Detect, 1 = 10BASE-T, 2 = AUI, 3 = 10BASE-2
	LA Decode Circuitry	4	0 = Not Present, 1 = Present (Req'd for decode above 1MB)
	HW Standby	3	0 = HW Standby not supported, 1 = HW Standby supported
	10BASE-2 Circuitry	2	0 = Not Present, 1 = Present
	AUI Circuitry	1	0 = Not Present, 1 = Present
	10BASE-T Circuitry	0	0 = Not Present, 1 = Present
25h	EEPROM Revision	15-0	Revision number of the EEPROM format definition used
26h	Reserved	15-0	Reserved for future use, set to 0
27h	Mfg Date		
	Year	15-9	e.g. 1011111b = 1995, 0000001b = 2001
	Month	8-5	e.g. 1b = Jan, 1100b = Dec
	Day	4-0	e.g. 1b = 1, 11111b = 31
28-2Ah	IEEE Individual Addr	47-0	Copy of words at 1C-1Eh
2Bh	Reserved	15-0	Reserved for future use, set to 0
2Ch	Reserved	15-0	Reserved for future use, set to 0
2Dh	Reserved	15-0	Reserved for future use, set to 0
2Eh	Reserved	15-0	Reserved for future use, set to 0
2Fh	Checksum	15-0	Word-wide checksum of words 1Ch to 2Fh (zero sum)
30h	EISA ID (low word)	15-0	EISA ID bits[7-0], EISA ID bits[15-8]
31h	EISA ID (high word)	15-0	EISA ID bits[23-16], EISA ID bits[31-24]
32h	Serial No (low word)	15-0	32-bit OEM assigned serial number, bits[15-8], bits[7-0]
33h	Serial No (high word)	15-0	32-bit OEM assigned serial number, bits[31-24], bits[23-16]
34h	Serial ID Checksum		
	Marker Byte	15-8	Constant 0Ah in high byte of checksum word
	LFSR Checksum	7-0	8-bit LFSR checksum of words 30h to 33h

Table 8. EEPROM Driver Configuration Block

IEEE Physical Address

The format of the 48-bit IEEE physical address as expected by the MAC driver is illustrated by the following example. (Must be initialized by OEM before shipping adapter.)

Example physical address: 000102030405h

Addr	Word	Description
1Ch	0100h	2 MSB of address (byte reversed)
1Dh	0302h	Middle 2 bytes (byte reversed)
1Eh	0504h	2 LSB of address (byte reversed)

ISA Configuration Flags

The ISA Configuration Flags specify how the CS8900A will utilize ISA system resources.

- Bit 15 Memory Mode Flag - Indicates the CS8900A will use shared memory for IO operations. Refer to the *CS8900A Data Sheet* for a description of the shared memory interface. Default is disabled.
- Bit 14 Boot PROM Flag - Indicates a Boot PROM is installed. Refer to the *CS8900A Data Sheet* for discussion of Boot PROM. (Must be initialized by OEM before shipping adapter.)
- Bit 13 StreamTransfer Mode - Refer to the *CS8900A Data Sheet* for description of SteamTransfer mode. Default is disabled.
- Bit 12 DMA Burst - Refer to BusCTL Register of the *CS8900A Data Sheet* for a discussion of DMA Burst control. Default is enabled.
- Bit 11 RxDMA Only - Refer to the *CS8900A Data Sheet* for a description of RxDMA Only mode. Default is disabled.
- Bit 10 Auto RxDMA - Refer to the *CS8900A Data Sheet* for a description of Auto RxDMA mode. Default is disabled.
- Bit 9 DMA Buffer Size - Refer to the *CS8900A Data Sheet* for a discussion of DMA Buffer size. Default is 16K.
- Bit 8 IOCHRDY Enable - Refer to the BusCTL Register, of the *CS8900A Data Sheet* for a discussion of IOCHRDY control. Default is enabled.
- Bit 7 UseSA - Refer to the BusCTL Register, of the *CS8900A Data Sheet* for a discussion of UseSA control. Default is enabled.
- Bits 6-4 DMA Channel Select - Refer to the *CS8900A Data Sheet* for a discussion of DMA channel selection for the CS8900A. Default is disabled.
- Bits 3-0 IRQ Channel Select - Refer to the *CS8900A Data Sheet* for the typical ISA Bus, CS8900A pin to pin connection. Cirrus' pre-written drivers expect the pins to be connected as described in the datasheet when running in an x86 system.

PacketPage Memory Base

Bits 15-4 12 MSB of Memory Base Address - The twelve most significant bits of the 24-bit address locating the base of the CS8900A's PacketPage memory. The lower twelve bits are assumed to be 0. Default is 0.

Bits 3-0 Reserved (set to 0)

Boot PROM Memory Base

Bits 15-4 12 MSB of Memory Base Address - The twelve most significant bits of the 24-bit address locating the base of the CS8900A's PacketPage memory. The lower twelve bits are assumed to be 0. Default is 0.

Bits 3-0 Reserved (set to 0)

Boot PROM Mask

Bits 15-4 12 MSB of Boot PROM Addr. Mask - Twelve-bit Boot PROM address mask. The lower twelve bits are assumed to be 0. Refer to the *CS8900A Data Sheet* for a discussion of the Boot PROM mask. Default is 0.

Bits 3-0 Reserved (set to 0)

Transmission Control

Bit 15 Full Duplex Mode - Specifies full-duplex or half-duplex mode for transmission. Default is 0 (half-duplex operation).

Bits 14-7 Reserved (set to 0)

Bit 6 Ignore Missing Media (IMM) - Specifies device driver's behavior if a cable or AUI is not connected during driver initialization. The driver's behavior can be summarized by the following four cases. Default is 0.

CASE 1 (IMM = 0, media autodetect selected, cable not connected)
Driver disables TX/RX and unloads if dynamic load/unload is supported by OS.

CASE 2 (IMM = 0, media type specified
[10B-T,AUI,10B-2], cable not connected)
Driver disables TX/RX and unloads if dynamic load/unload is supported by OS.

CASE 3 (IMM = 1, media autodetect selected, cable not connected)
Driver disables TX/RX and unloads if dynamic load/unload is supported by OS.

CASE 4 (IMM = 1, media type specified
[10B-T,AUI,10B-2], cable not connected)
Driver remains resident, reports "Media type **XXXXXX** not detected", and functions normally if/when the specified cable type is connected.

Bits 5-0 Reserved (set to 0)

Adapter Configuration Word

- Bits 15-13 Reserved (set to 0)
- Bits 12-11 Optimization Flags
Used to specify the platform's OS configuration to the driver. Each driver configures the CS8900A for optimum performance based on the platform's OS and driver architecture (NDIS 2X, ODI, NDIS 3X, etc.). Default is DOS (single threaded OS).
- Bits 10-8 Reserved (set to 0)
- Bit 7 DC to DC Converter Polarity
Refer to "10BASE-2 Interface" on page 27. (Must be initialized by OEM before shipping adapter.)
- Bit 6-5 Media Type In Use
Specifies the type of media the driver should use (10BASE-T, AUI, 10BASE-2) or if driver should auto-detect media in use. Default is auto-detect.
- Bit 4 Adapter Provides LA Decode Circuitry
Specifies the presence of LA decode circuitry on the adapter. Refer to "Extended Memory Mode" on page 31. (Must be initialized by OEM before shipping adapter.)
- Bit 3 Adapter Provides HW Standby Circuitry
Specifies the presence of hardware standby circuitry on the adapter. Refer to the *CS8900A Data Sheet*. (Must be initialized by OEM before shipping adapter.)
- Bit 2 Adapter Provides 10BASE-2 Circuitry
Specifies the presence of 10BASE-2 circuitry on the adapter. (Must be initialized by OEM before shipping adapter.)
- Bit 1 Adapter Provides AUI Circuitry
Specifies the presence of AUI circuitry on the adapter. (Must be initialized by OEM before shipping adapter.)
- Bit 0 Adapter Provides 10BASE-T Circuitry
Specifies the presence of 10BASE-T circuitry on the adapter. (Must be initialized by OEM before shipping adapter.)

EEPROM Revision

Specifies the revision level of the format definition used by this EEPROM. A value of 0 indicates the first revision level, a value of 1 indicates the second revision level, and so on.

Manufacturing Date

This word is the adapter's manufacture date encoded in 16 bits, YR-MO-DY format. (Must be initialized by OEM before shipping adapter.)

- Bits 15-9 Two Least-significant Digits of Year
Seven bits for a range of 00 to 99 decimal. A roll-over to 00 will be interpreted as the year 2000.
- Bits 8-5 Month
Four bits for a range of 01 to 12.
- Bits 4-0 Day
Five bits for a range of 01 to 31.

IEEE Physical Address (Copy)

This field is a copy of the three words at address 1Ch to 1Eh. (Must be initialized by OEM before shipping adapter.)

16-bit Checksum

The checksum stored at the end of the block is the 2's complement of the 16-bit sum of all the preceding words in the Driver Configuration Block. (The drivers access the Configuration Block as 16-bit words.) Any carry out of the 16th bit is ignored. Since this checksum value is calculated as the 2's complement of the sum of all the preceding words in the block, a total of 0 should result when the checksum value is added to the sum of the previous words. (Must be initialized by OEM before shipping adapter.)

EISA ID

The two EISA words make up the 32-bit EISA Product Identification Code.

- Low Word These 16 bits make up the 3-letter identifier string of the OEM's EISA ID in 5-bit compressed ASCII. (A = 00001, B = 00010, C = 00011, etc.)
- Bits 7-0 High order 8 bits of 16-bit value
- Bits 15-8 Low order 8 bits of 16-bit value
- High Word These 16 bits make up the OEM's product ID No.
The upper order 11 bits are the product ID number and the lower order 5 bits are the revision number.
- Bits 7-0 High order 8 bits of 16-bit value
- Bits 15-8 Low order 8 bits of 16-bit value

Serial Number

The two serial number words make up the unique 32-bit OEM serial number for the adapter.

Low Word

Bits 7-0 bits[7-0] of 32-bit serial number

Bits 15-8 bits[15-8] of 32-bit serial number

High Word

Bits 7-0 bits[31-24] of 32-bit serial number

Bits 15-8 bits[23-16] of 32-bit serial number

Serial ID Checksum

Word 34h contains an 8-bit LFSR checksum calculated on the EISA ID and OEM serial number (words 30h to 33h). The 8-bit LFSR checksum is placed in the low byte of 34h. The high byte is padded with the constant 0Ah.

Maintaining EEPROM Information

The contents of the EEPROM may either be pre-programmed in a stand-alone EEPROM programmer or programmed after installation through the CS8900A's serial interface. See the *CS8900A Data Sheet* for programming an EEPROM via the CS8900A's serial interface. The OEM is left to determine the best procedure for programming EEPROMs via a stand-alone EEPROM programmer.

Cirrus has two utilities suitable for maintaining the configuration information stored in the EEPROM. IAGEN.EXE generates a file with individual addresses and serial numbers. EEPROM.EXE is designed to be used by OEMs to initialize the EEPROM's contents before shipping to the end-user. It takes the file generated by IAGEN.EXE as input. Both utilities are available as executables and source code on request.

Cirrus also provides SETUP.EXE, a DOS-based Setup and Installation Utility run by the end-user at the time the adapter is installed. The DOS-based Setup and Installation utility allows the end-user to configure the adapter for a specific system.

Embedded Designs

Embedded designs may be implemented using an on-board serial EEPROM connected to the CS8900A in the same manner as is used in adapter board designs. However, to save board space and reduce costs, motherboard implementations can store the Driver Configuration Block in the system's BIOS nonvolatile memory.

BIOS-Based Design Considerations

For Cirrus supplied MAC drivers to interface with a Driver Configuration Block (DCB) stored in BIOS, the DCB's data structure must meet the following requirements:

- 3) The base of the data structure must be marked by a header consisting of the 8-byte ASCII text string "\$CS8900A\$".

- 4) The header must be located on a 512-byte boundary in the BIOS space between C0000h and FFC00h.
- 5) The data structure must employ the same format as defined for EEPROM in Table 8.

An additional design consideration when storing the Driver Configuration Block in BIOS space concerns the inability to override the CS8900A's default configuration after reset. If an EEPROM is not connected to the CS8900A, it will always come out of reset using its default configuration. Therefore, when using BIOS space to store configuration information, IO addresses of 300h - 310h must be dedicated to the CS8900A.

The CS8900A's configuration can be changed from its default values through software control after reset. However, it will always revert to its default configuration after each reset (including software resets). Refer to Table 3.3 of the *CS8900A Data Sheet* for default configuration definitions.

Driver Interface with BIOS-Based Configuration

During initialization, Cirrus-provided drivers test for the presence of an EEPROM. If an EEPROM is not detected, the drivers scan the BIOS for the header indicating the start of a Driver Configuration Block. Before using the data in the Driver Configuration Block, the drivers verify the data in the block is valid using a checksum.

The checksum stored at the end of the block is the 2's complement of the 16-bit sum of all the words in the Driver Configuration Block, excluding the 8 bytes of header. (The drivers access the Configuration Block in BIOS space as 16-bit words.) Any carry out of the 16th bit is ignored. Since this checksum value is calculated as the 2's complement of the sum of all the preceding words in the block, a total of 0 should result when the checksum value is added to the sum of the previous words. Table 9 shows the correct format for a data struc-

ture storing the Driver Configuration Block in BIOS space.

Byte Offset	Description	Function
00h	Header	8 bytes = "\$CS89XX\$"
08h	Individual Address	IEEE individual address. Same format as word 1Ch in Table 8
0Ah	Individual Address	IEEE individual address. Same format as word 1Dh in Table 8
0Ch	Individual Address	IEEE individual address. Same format as word 1Eh in Table 8
0Eh	ISA Configuration Flags	Same format as word 1Fh in Table 8
10h	Packet Page Base	12 MSBs of 24-bit address (lower 12 bits assumed = 0)
12h	Boot PROM Base	12 MSBs of 24-bit address (lower 12 bits assumed = 0)
14h	Boot PROM Mask	12 MSBs of 24-bit addr mask (lower 12 bits assumed = 0)
16h	Transmission Control	Same format as word 23h in Table 8
18h	Adapter Configuration	Same format as word 24h in Table 8
1Ah	EEPROM Revision	Same format as word 25h in Table 8
1Ch	Reserved	Reserved for future use, set to 0
1Eh	Mfg Date	Same format as word 27h in Table 8
20h-25h	IEEE Individual Addr	Copy of 6 bytes at offset 08h
26h	Reserved	Reserved for future use, set to 0
28h	Reserved	Reserved for future use, set to 0
2Ah	Reserved	Reserved for future use, set to 0
2Ch	Reserved	Reserved for future use, set to 0
2Eh	Checksum	Word-wide checksum of words 08h to 2Fh (zero sum)
30h	EISA ID (high word)	Same format as word 30h in Table 8
32h	EISA ID (low word)	Same format as word 31h in Table 8
34h	Serial Number	Same format as word 32h in Table 8
36h	Serial Number	Same format as word 33h in Table 8
38h	LDSR Checksum	Same format as word 34h in Table 8

Table 9. Format of Driver Configuration Block in BIOS space

OBTAINING IEEE ADDRESSES

Each node of a Local Area Network has a unique address for the media access control (MAC). This makes it possible for that particular node to have unique identity for data communication. This address, known as the IEEE physical address, consists of 48 bits of data. This address is assigned to a LAN physical interface node by the manufacturer of the network interface card.

To ensure uniqueness of the address, 24 bits of out of the 48 bits of the physical address are assigned to the manufacturer by the IEEE standards committee. This 24 bit address is known as Organizationally Unique Identifier (OUI). The remaining 24 bits of the address are assigned by the manufactur-

er. For further information and an application for an OUI, please contact the IEEE at the following address:

IEEE Registration Authority,
IEEE Standards Department,
445 Hoes Lane, PO Box 1331
Piscataway, NJ 08855-1331, USA

Telephone: (908) 562-3813
FAX: (908) 562-1571

Adapter boards shipped as part of Cirrus' CS8900A Evaluation Kit are programmed with an IEEE Physical Address obtained from an allotment assigned to Cirrus Logic by the IEEE.

DEVICE DRIVERS AND SETUP/INSTALLATION SOFTWARE

This chapter discusses the software provided by Cirrus for use with the CS8900A. That software includes a broad family of device drivers, driver-related data files, and utilities. A single-user, evaluation copy of that software is included with this Kit. The following drivers are included in the Kit:

- Novell ODI 4.x DOS (for use with Netware clients)
- Novell ODI 4.x OS/2 driver (for use with Netware OS/2 clients)
- Novell ODI 4.x Server driver
- Microsoft NDIS 3.X driver (for use with Windows 95, 98, Windows NT, and Windows for Workgroups)
- Microsoft NDIS 2.X DOS driver (for use with many NOSs including Microsoft LAN MANAGER, IBM LAN SERVER, Banyan Vines, LANtastic, DEC Pathworks)
- Microsoft NDIS 2.X driver for OS/2
- Boot PROM program (for ODI and NDIS) allowing a diskless PC to load a simple LAN driver from PROM and then use the simple driver to boot DOS from a server over the network. Also known as RIPL (Remote Initial Program Load).
- Packet Driver V1.09 (for use with TCP/IP protocol stacks, including PC/TCP, SUN PC-NFS, Wollongong)
- SCO UNIX driver and installation script

Additionally Cirrus provides two utility programs:

- DOS Setup and Installation Utility
- EEPROM Programming Utility, for use in OEM manufacturing environments.

Additional drivers and links to other supported operating systems may be found on the Cirrus website, <http://www.cirrus.com>.

Cirrus's Software Licensing Procedures

The CS8900A developer's kit contains a single-user copy of object code which is available only for

internal testing and evaluation purposes. This object code may not be distributed without first signing a LICENSE FOR DISTRIBUTION OF EXECUTABLE SOFTWARE, which may be obtained by contacting your sales representative. The LICENSE FOR DISTRIBUTION OF EXECUTABLE SOFTWARE gives you unlimited, royalty-free rights to distribute Cirrus-provided object code.

DOS Setup and Installation Utility

SETUP.EXE allows you to install a driver (in a non UNIX machine), and to configure a CS8900A-based adapter card.

The Utility will allow the user to select configuration settings, for example, interrupt number, DMA channel, IO base address and memory base address. The selected values are stored in the CS8900A's EEPROM and will thereafter be loaded from the EEPROM, whenever the CS8900A IC is reset.

The Utility is menu driven. The menu items can be selected using either the mouse, or the arrow keys. The arrow keys are enabled by first typing the ALT key.

In an embedded or motherboard application (non-adapter-card application), there may not be an EEPROM attached to the CS8900A. In this case, the system BIOS may store the CS8900A configuration information in system memory such as system CMOS. This utility is not applicable to such embedded or motherboard applications.

Installation Procedure

- 1) Install the CS8900A-based adapter card into the PC. The adapter must be installed to use the Setup and Installation Utility.
- 2) Place the DOS Setup and Installation Utility diskette into drive A: (or B:).
- 3) From a DOS prompt, type: A:\SETUP (or B:\SETUP)

- 4) The current configuration of the adapter will be displayed. Click on OK or press the Enter key to proceed.
- 5) Press the ALT key then use the Adapter/Manual configuration options to manually override any of the current configurations setting shown.
- 6) Use Diagnostics/Self Test to test the functionality of the card.
- 7) Use the Diagnostic/Network Test screen to test the ability of the card to communicate across the Ethernet with another CS8900A-based card which is also running the DOS Setup and Installation Utility.

CONTACTING CUSTOMER SUPPORT AT CIRRUS

Cirrus Logic is committed to providing the industry's most easily implemented Ethernet solution.

We invite you to contact us for assistance at any time during the design process. Our Application Engineering department offers free schematic and layout review services and provides software support for Cirrus's network drivers. Let Cirrus's application engineers help you confirm the optimum design for your specific application.

To contact Cirrus Application Engineering, call **(800) 888-5016** (from the US and Canada) or **512-442-7555** (from outside the US and Canada), and ask for CS8900A Application Support, or send an email to: ethernet@crystal.cirrus.com.

Cirrus Web Site

Cirrus also offers free updates to the of the network driver software using the Cirrus website:

<http://ww.cirrus.com>.

SMART
Analog™



LittleDiode supplies new, hard to find or obsolete electronic components and semiconductors all over the world.

With over two million different components listed you are sure to find the part you need.

Feel free to visit us today at our online store:

LittleDiode.com

Looking forward to providing you with the best possible service.