

250W HIGH POWER FACTOR SUPPLY FOR TV

INTRODUCTION

This application has been designed to provide a complete supply for colour TV. The system has been configured using a Flyback DC-DC converter with an upstream PFC section in order to improve the characteristics of the whole supply. The architecture of the system consists of a L4981A controller with the relevant circuitry for the PFC section, and of a TEA2261 synchronised, in master-slave configuration, with a TEA5170 at 15 kHz switching frequency. When the supply is in stand-by condition, the TEA2261 controller operates in burst mode.

System block diagram. (fig.1)

System Main Features:

- Input Voltage Range: 176 to 270 Vac
- Rated Output Power: 250W
- Power Factor at max. Output Power: 0.98
- Input Power in Stand-by mode: 3W
- DC Preregulated Voltage: 400
- Efficiency: > 80%
- Operating Frequency: 15kHz Synchronised

(only Fly-Back Section)

- Minimum Output Power Synchronised : 8.5 W
- Others: Short Circuit, Overload and Open Load Protection.

DESCRIPTION.

How to use the demoboard:

The evaluation board is provided with a multi-contact switch (sw.1) which allows to simulate the TVC operations. The procedure is very simple:

1) Put the switch (1) in s-by position and then switch on the board.

In this condition no pulses are coming from the TEA5170 I.C. , T1 is in on state grounding C9 (at soft start pin of L4981) and so the PFC section is not working. It is possible to test the voltage at the output of the step-up (PFC) section C23. It must be about 308 V (depending on the mains voltage). The outputs of the converter should be measured, and the values can be adjusted with P1 placed at the primary side.

Here below the schematic diagram is shown in Fig 2a, PCB and components layout in Fig. 2b.

Figure 1.

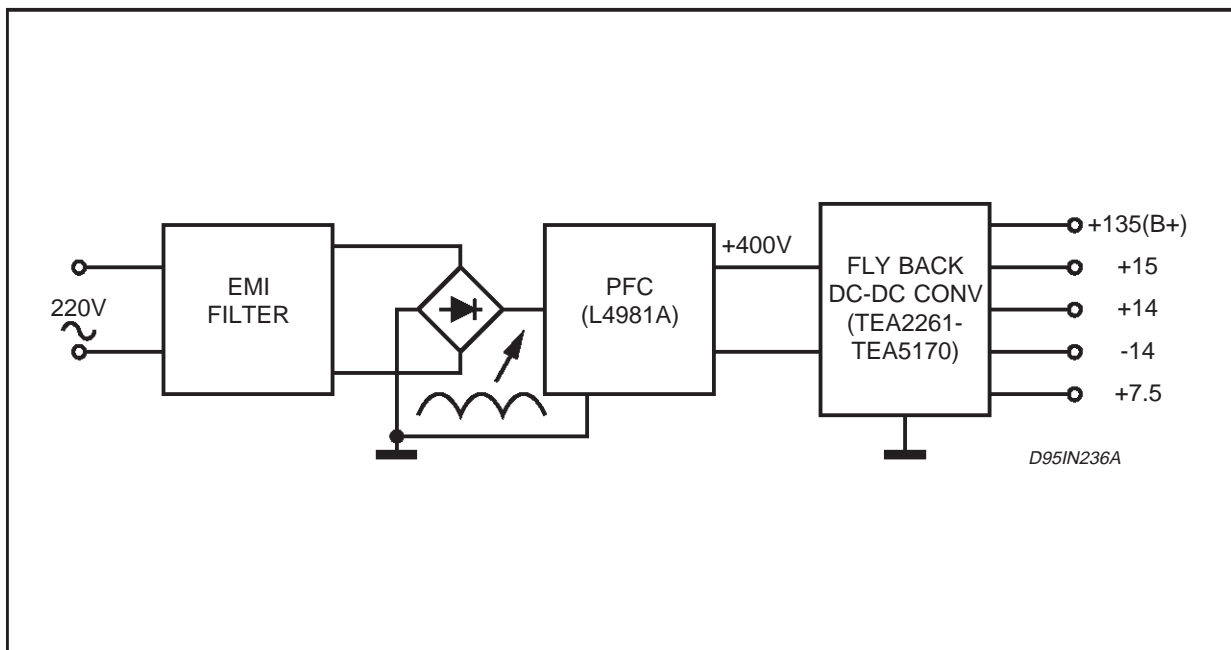

APPLICATION NOTE

Figure 2a: Schematic Diagram.

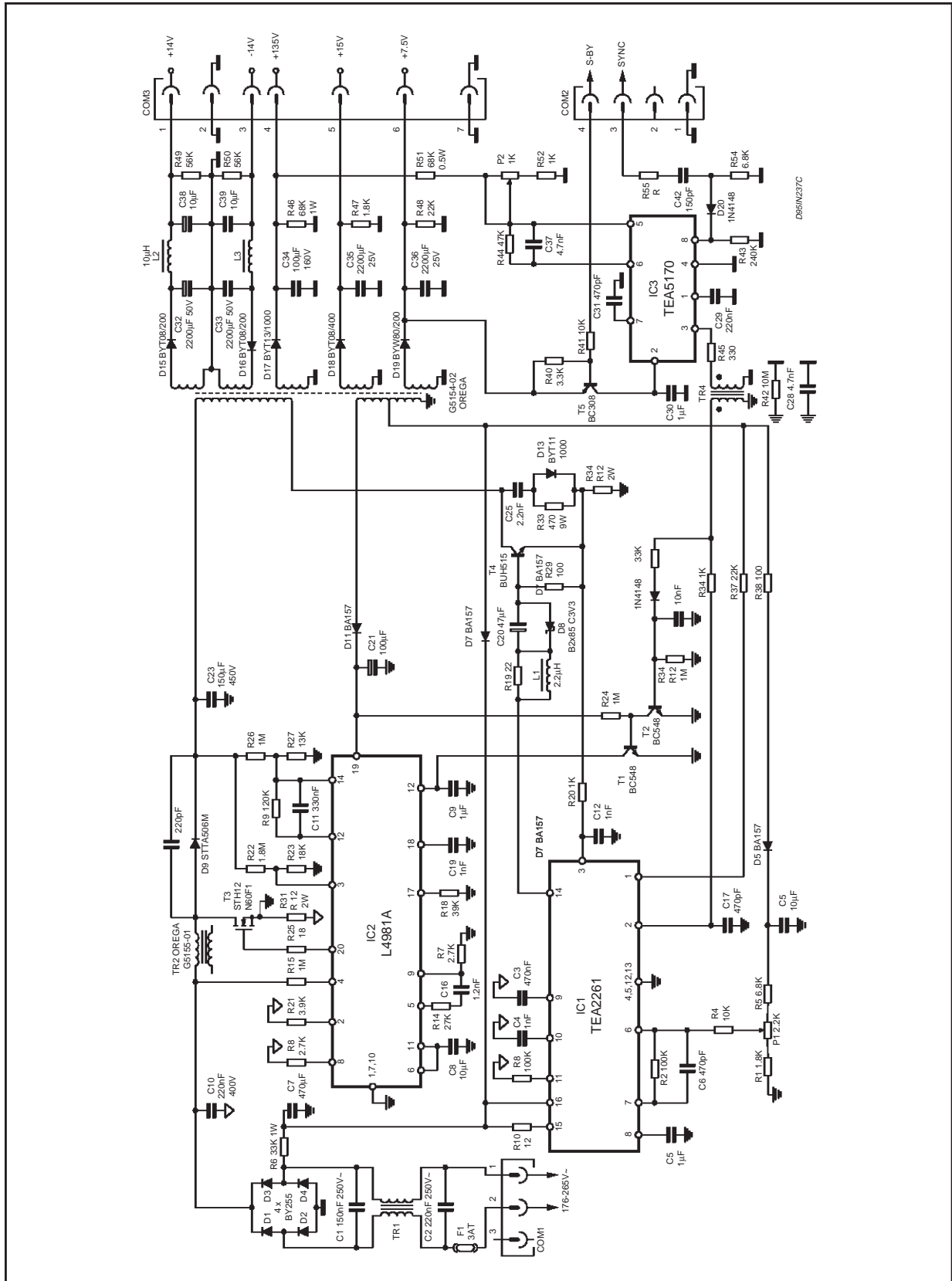
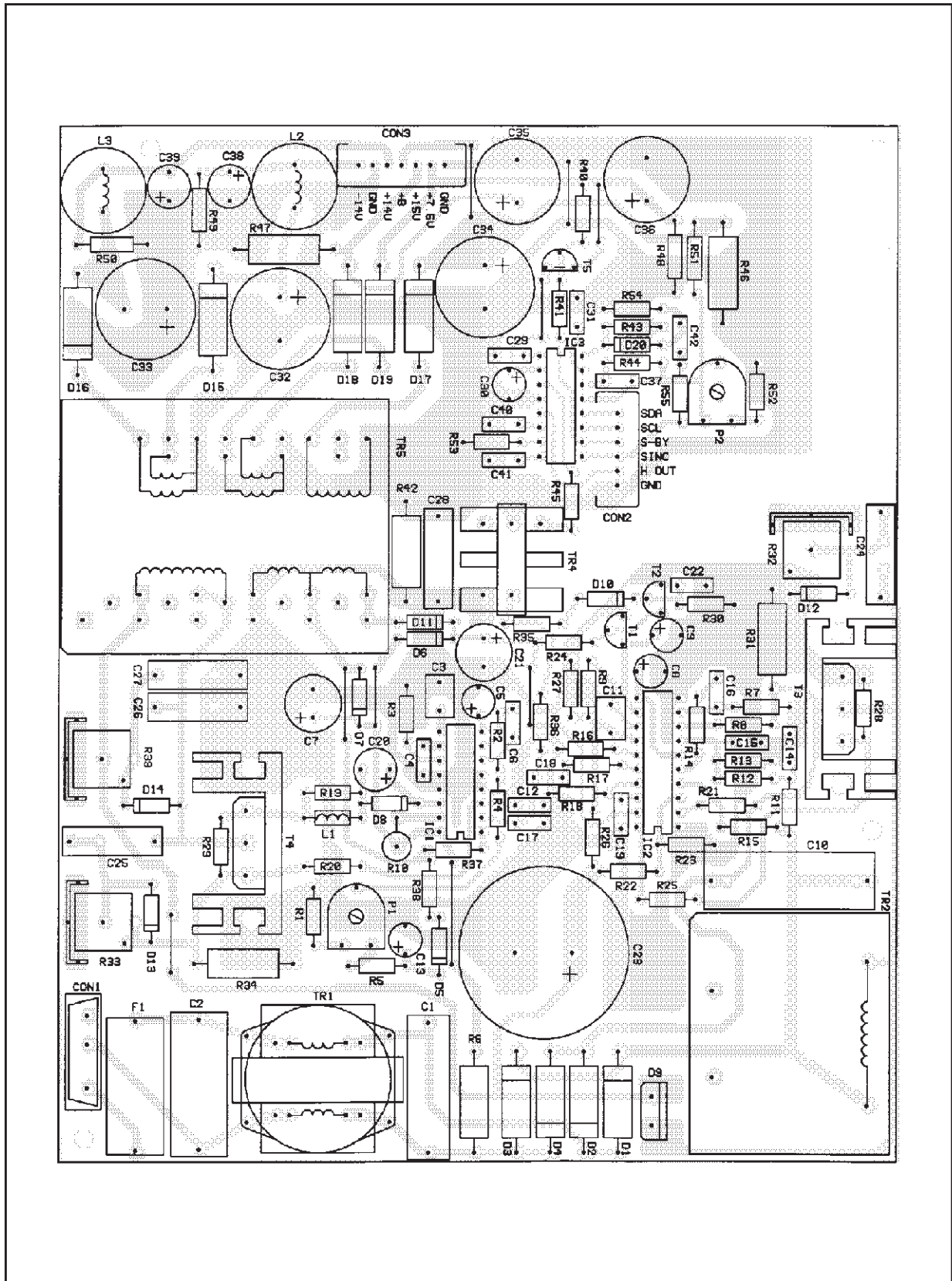
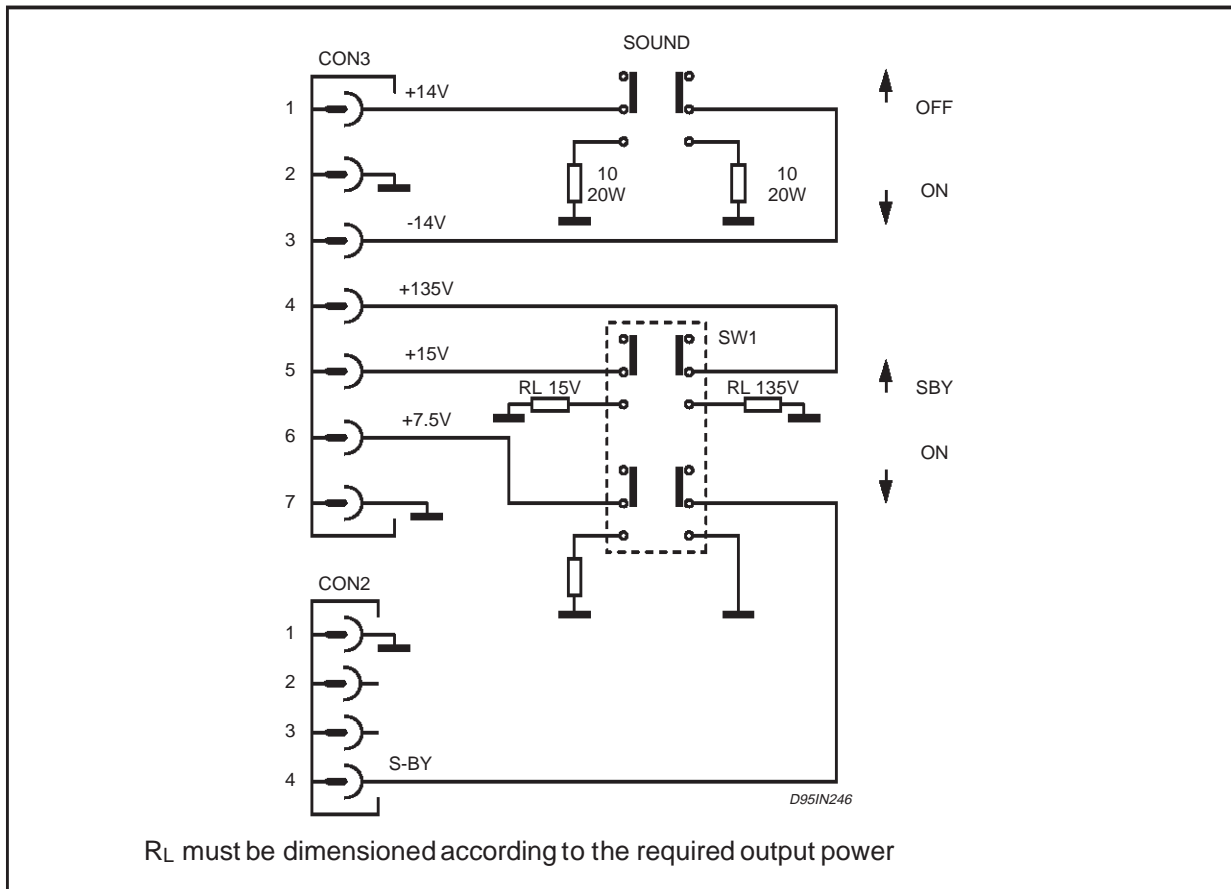

Figure 2b: PCB and components layout.



APPLICATION NOTE

Figure 3: TVC Simulation with External Resistive Loads.



On the evaluated board (refer to CON3 in fig.3) the adjusted voltage values are:

Voltage at out 1 = +16.5V

Voltage at out 3 = -16.5V

Voltage at out 4 = +13.7V

Voltage at out 1 = +15.7V

Voltage at out 1 = +10V

As the "stand-by" output values have been set, put the switch in ON position. The loads are now connected and all the circuits of the application run. The TEA5170 is now supplied and it sends PWM pulses from the secondary to the primary side of the converter. T2 is turned on, T1 is cut-off, thus enabling the L4981A to start. As the PFC runs, the voltage at the bulk capacitor C23 reaches 400V.

TEST RESULTS:

Output Voltage	405V (at 230W output power).
Output Power	10 to 250W
Efficiency	85% (at Max. output power)
Power Factor	0.998
THD at max. output power:	3.5%
Power Factor in Stand-by Mode:	0.3
THD in Stand-by Mode:	70%
Efficiency at min. Output Power:	0.5 (Pi min = 17W)
Minimum Output Power = 8.5W	$135V \cdot 18mA + 15V \cdot 300mA + 7.5V \cdot 250mA$

Load Regulation:

a) 135V Output (4) = $\pm 0.12\%$ @	lo4 (135V) = 0.05 to 1A lo5 (15V) = 2.5A lo6 (7.5V) = 2.5A lo1 (14V) = 1.3A lo3 (-14V) = -1.3A
b) 135V Output (4) = $\pm 0.75\%$ @	lo4 (135V) = 1A lo5 (15V) = 2.5A to 0A lo6 (7.5V) = 2.5A lo1 (14V) = 1.3A lo3 (-14V) = -1.3A
c) 135V Output (4) = $\pm 0.75\%$ @	lo4 (135V) = 1A lo5 (15V) = 2.5A lo6 (7.5V) = 2.5A to 0A lo1 (14V) = 1.3A lo3 (-14V) = -1.3A
d) 135V Output (4) = $\pm 0.1\%$ @	lo4 (135V) = 0.05A lo5 (15V) = 2.5A lo6 (7.5V) = 2.5A lo1 + 3 ($\pm 14V$) = -1.3A to 0A
$\pm 14V$ Output (1 + 3) = +60% for	I = 1.3 to 0A

In the attached photos (1 to 4) the essential waveforms are depicted (ref. fig. 2a).

Photo 1: PFC Section
(Pout = 230W; $I_L = 1A/div$; $V_i = 100V/div$;
 $t = 2ms/div$)

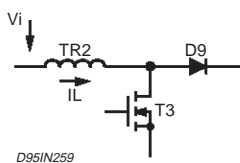
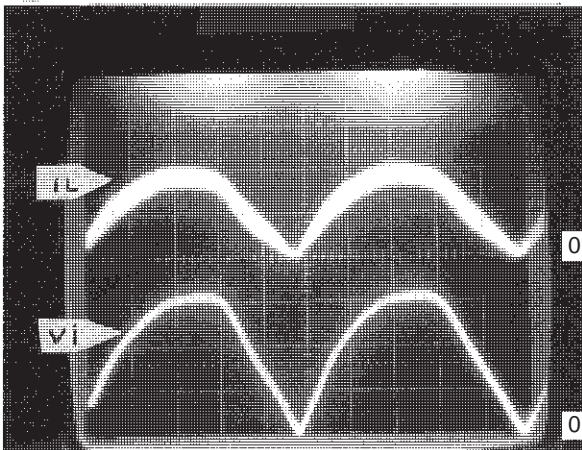
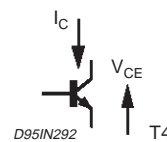
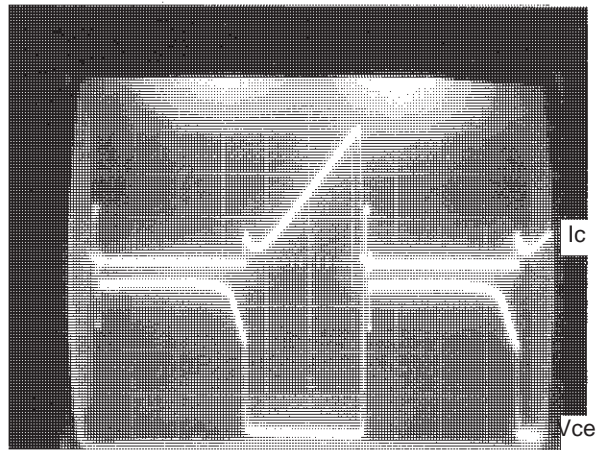

Photo 2: Flyback Section
(Pout = 230W; $I_c = 1A/div$; $V_{ce} = 200V/div$;
 $t = 10\mu s/div$)



APPLICATION NOTE

Photo 3: Stand-By Mode
Turn-off transistor BUH517 ($I_C = 0.5A/div$;
 $V_{ce} = 200V/div$; $t = 0.5\mu s/div$)

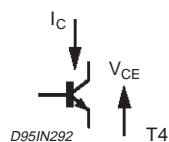
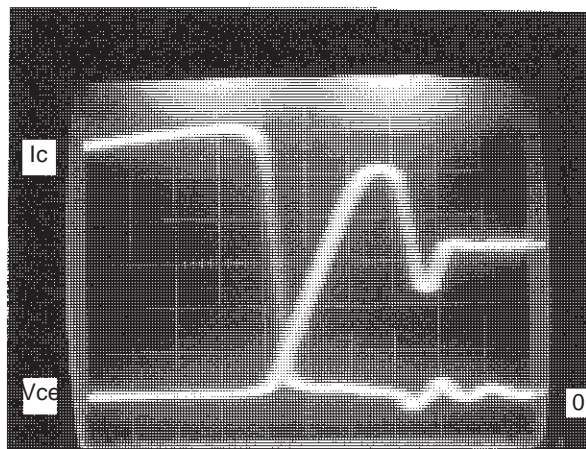
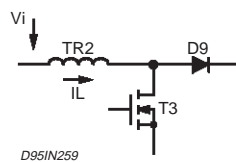
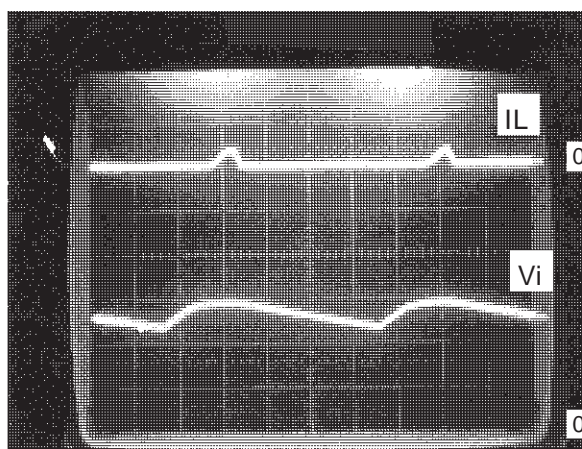

Photo 4: Stand-By Mode
PFC at Bulk Capacitor ($I_L = 0.5A/div$;
 $V_i = 100V/div$; $t = 2ms/div$)



Information furnished is believed to be accurate and reliable. However, SGS-THOMSON Microelectronics assumes no responsibility for the consequences of use of such information nor for any infringement of patents or other rights of third parties which may result from its use. No license is granted by implication or otherwise under any patent or patent rights of SGS-THOMSON Microelectronics. Specification mentioned in this publication are subject to change without notice. This publication supersedes and replaces all information previously supplied. SGS-THOMSON Microelectronics products are not authorized for use as critical components in life support devices or systems without express written approval of SGS-THOMSON Microelectronics.

© 1997 SGS-THOMSON Microelectronics – Printed in Italy – All Rights Reserved

SGS-THOMSON Microelectronics GROUP OF COMPANIES

Australia - Brazil - Canada - China - France - Germany - Italy - Japan - Korea - Malaysia - Malta - Morocco - The Netherlands -
Singapore - Spain - Sweden - Switzerland - Taiwan - Thailand - United Kingdom - U.S.A.



LittleDiode supplies new, hard to find or obsolete electronic components and semiconductors all over the world.

With over two million different components listed you are sure to find the part you need.

Feel free to visit us today at our online store:

LittleDiode.com

Looking forward to providing you with the best possible service.