

UNDERSTANDING POWER FACTOR

by L. Wuidart

IF YOU THINK THAT POWER FACTOR IS ONLY $\cos \phi$, THINK AGAIN !

The big majority of Electronics designers do not worry about Power Factor (P.F.)

P.F. is something you learnt one day at school in your Electrotechnics course"as being $\cos \phi$.

This conventional definition is only valid when considering IDEAL Sinusoidal signals for both current and voltage waveforms.

But the reality is something else, because most off-line power supplies draw a non-sinusoidal current!

Many off-line systems have a typical front-end section made by a rectification bridge and an input filter capacitor.

This front-end section acts as a peak detector (see figure 1).

A current flows to charge the capacitor only when the instantaneous AC voltage exceeds the voltage on the capacitor.

A single phase off-line supply draws a current pulse during a small fraction of the half-cycle duration.

Between those current peaks, the load draws the energy stored inside the input capacitor. The phase lag ϕ but also the harmonic content of such a typical pulsed current waveform produce non efficient extra RMS currents, affecting then the real power available from the mains.

So, P.F. is much more than simply $\cos \phi$!

The P.F. value measures how much the mains efficiency is affected by BOTH phase lag ϕ AND harmonic content of the input current.

In this context, the standard European project

Figure 1: Full Wave Bridge Rectifier Waveforms.

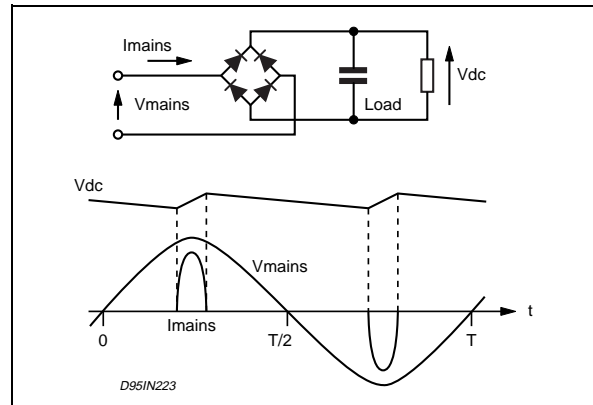

IEC555-2 only defines the current harmonic content limits of mains supplied equipments.

THEORETICAL MEANING

The power factor (P.F.) is defined by:

$$P.F. = \frac{P}{S} = \frac{\text{REAL POWER}}{\text{TOTAL APPARENT POWER}}$$

Ideal Sinusoidal Signals

Both current and voltage waveforms are assumed to be IDEAL SINUSOIDAL waveforms. If the phase difference between the input voltage and the current waveforms is defined as the phase lag angle or displacement angle, the corresponding graphical representation of power vectors gives:

The corresponding power give:

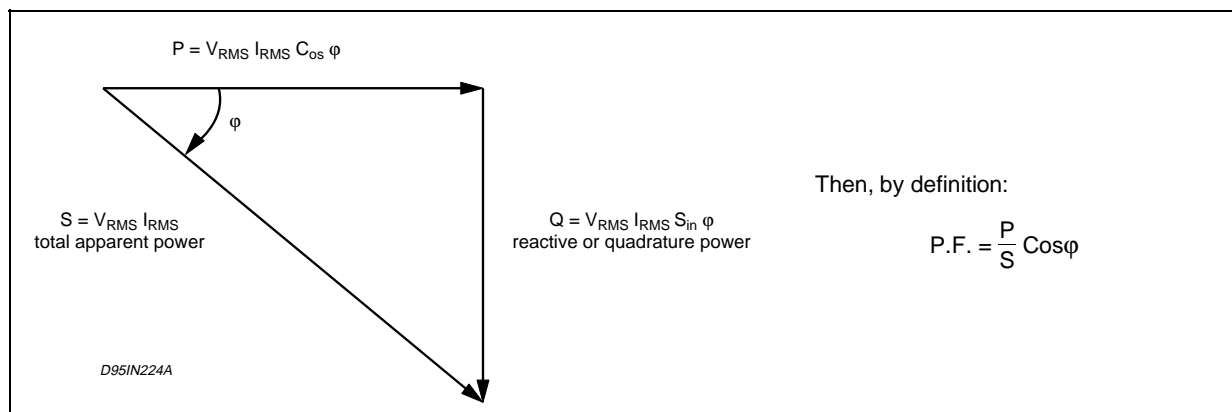

APPLICATION NOTE

Non-ideal sinusoidal current waveform

Assume that the mains voltage is an IDEAL SINUSOIDAL voltage waveform. Its RMS value is:

$$V_{RMS} = \frac{V_{peak}}{\sqrt{2}}$$

If the current has a periodic non-ideal sinusoidal waveform, the FOURIER transform can be applied

$$I_{RMS\ total} = \sqrt{I_0^2 + I_{1RMS}^2 + I_{2RMS}^2 + \dots + I_{nRMS}^2}$$

Where I_0 is the DC component of the current, I_{1RMS} the fundamental of the RMS current and $I_{2RMS} \dots I_{nRMS}$ the harmonics

For a pure AC signal:

$$I_0 = 0$$

The fundamental of the RMS current has an in-phase component $I_{1RMS P}$ and a quadrature component $I_{1RMS Q}$.

So, the RMS current can be expressed as:

$$I_{RMS\ total} = \sqrt{I_{1RMS P}^2 + I_{1RMS Q}^2 + \sum_{n=2}^{\infty} I_{nRMS}^2}$$

Then, the Real Power is given by:

$$P = V_{RMS} \cdot I_{1RMS P}$$

As φ_1 is the displacement angle between the input voltage and the in-phase component of the fundamental current:

$$I_{1RMS P} = I_{1RMS} \cos \varphi_1$$

and

$$P = V_{RMS} \cdot I_{1RMS} \cdot \cos \varphi_1$$

$$S = V_{RMS} \cdot I_{RMS\ total}$$

Then, the Power Factor can be calculated as:

$$P.F. = \frac{P}{S} = \frac{I_{1RMS} \cdot \cos \varphi_1}{I_{RMS\ total}}$$

One can introduce the k factor by

$$k = \frac{I_{1RMS}}{I_{RMS\ total}} = \cos \Theta$$

Θ is the distortion angle. The k factor is linked to the harmonic content of the current. If the harmonic content of $I_{RMS\ total}$ is approaching zero, $k \rightarrow 1$.

Conclusion

Finally P.F. can be expressed by:

$$P.F. = \cos \Theta \cdot \cos \varphi_1$$

So, the power vectors representation becomes

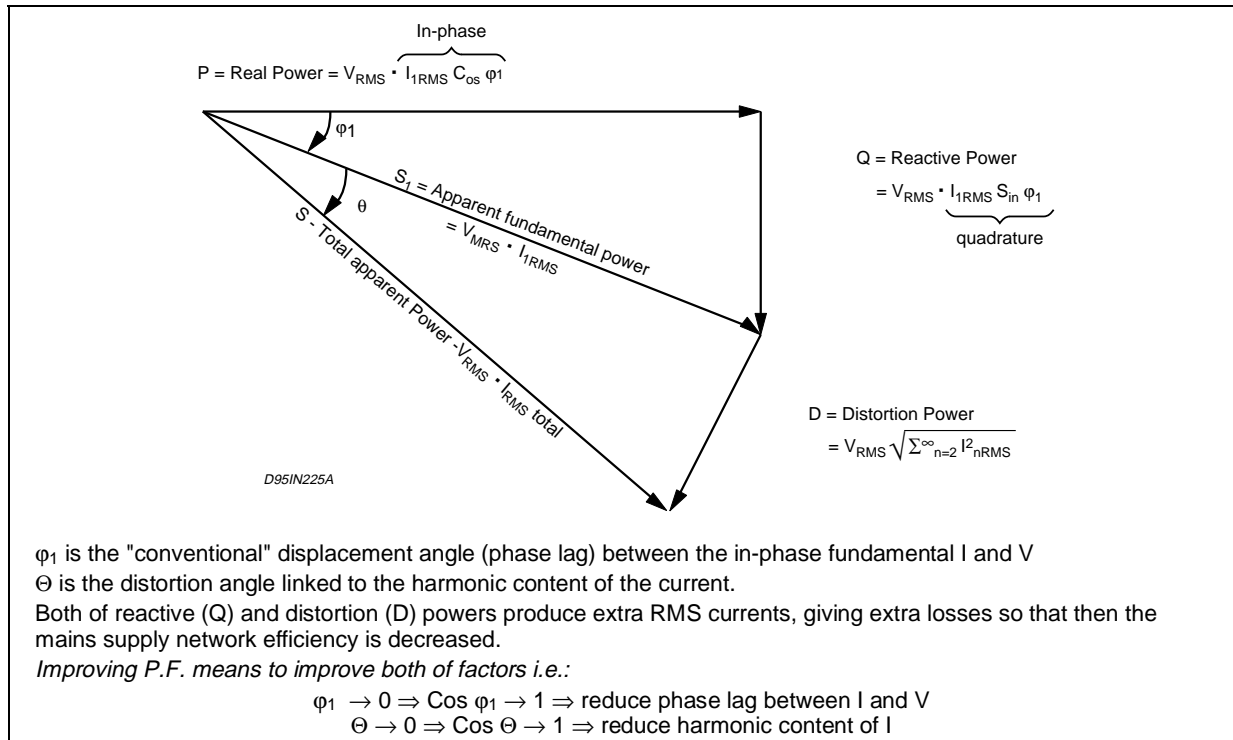

PRACTICAL MEANING

The unity power factor beneficiaries

Both of the user and the Electricity distribution company take advantage from a unity power factor. Moreover, adding a PFC brings components cost reduction in the downstream converter.

The user's benefit

At minimum line voltage (85V_{AC}), a standard 115V_{AC} well socket should be able to deliver the nominal 15A to a common load. In similar conditions, a "non-corrected power factor" SMPS (typical value of 0.6) drops the available current from 15A to only 9A. For example, from one wall socket, four 280W computers each equipped with P.F.C. can be supplied instead of two with no P.F.C.

The Electricity distribution company benefit

Both of reactive (Q) power and distortion (D) power produce extra RMS currents. The resulting extra losses significantly decrease the mains supply network efficiency. This leads to oversize the copper area of distribution power wires (see figure 3). The distortion power is linked to the current harmonic content. Delivering power at other frequencies than the line frequency causes a lot of drawbacks. The current distortion disturbs the zero crossing detection systems, generates overcurrent in the neutral line and resonant overvoltages. In Europe, the standard EN 60555 and the international project IEC 555-2 limit the current harmonic content of mains supplied equipments.

Figure 2: Reactive and distortion power produce extra RMS currents leading to copper area oversize.

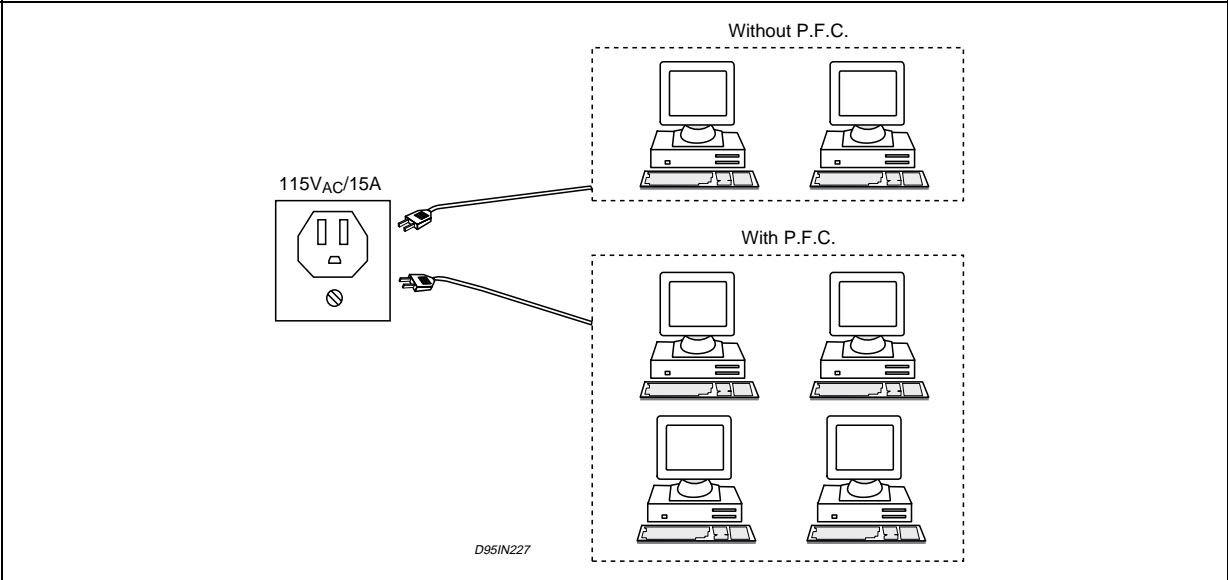
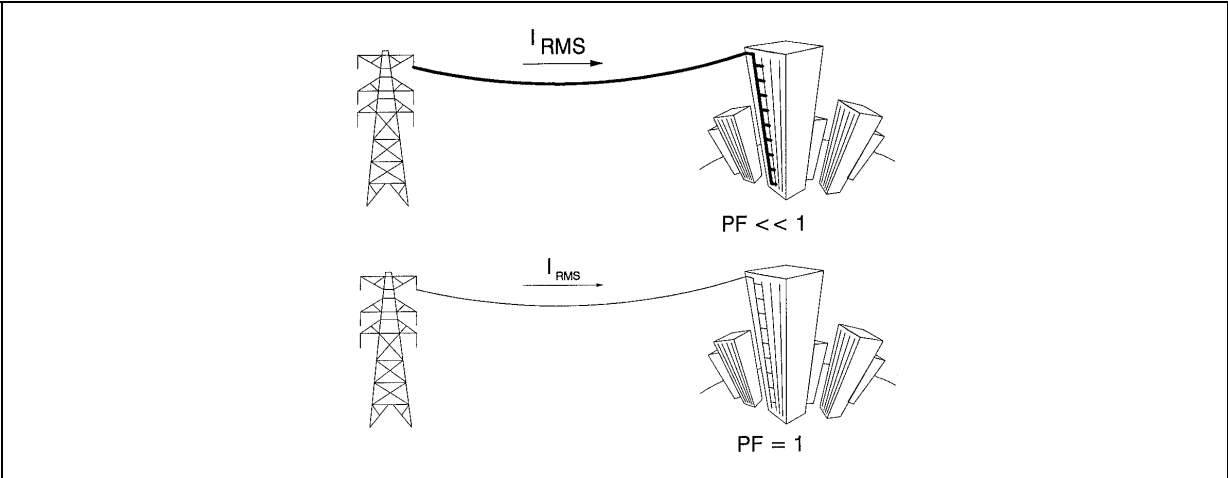

Figure 3: Reactive and distortion power produce extra RMS currents leading to copper area oversize.



APPLICATION NOTE

Components cost reduction in the downstream converter

For the same output power capability, a conventional converter using a input mains voltage doubler, is penalized by a 1,8 times higher primary RMS current than with a PFC preregulator.

Consequently, the PFC allows to select power MOSFET's switches with up to 3 times higher on resistance ($r_{ds\ on}$) in the downstream converter (see figure 4).

The converter transformer size can be optimized not only because the copper area is smaller but also, due to the regulated DC bulk voltage deliv-

Figure 4: Power MOSFET On-resistance ($r_{ds\ on}$) is 3 times higher by using a PFC.

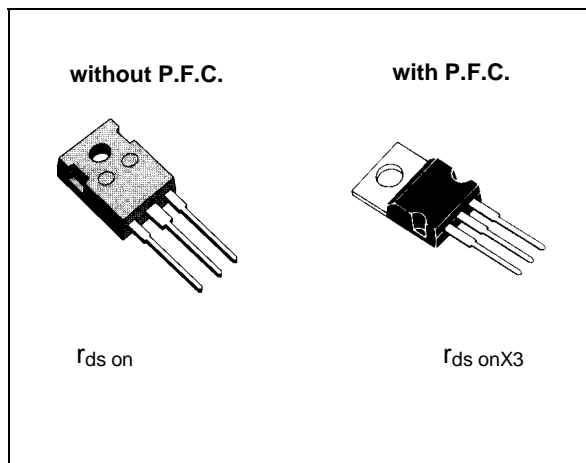

ered by the PFC preregulator.

The PFC provides an automatic mains selection on a widerange voltage from 85V_{AC} up to 265V_{AC}. Compared to the conventional doubler front-end section, the same "hold-up" time can be achieved with a 6 times smaller bulk storage capacitor.

To get 10ms hold-up time, a 100W converter in doubler operation requires a series combination of two 440 μ F capacitors instead of one 130 μ F with PFC.

General comments

For new developments, SMPS designers will have to consider the IEC 555-2 standard.

In the practice, this leads to use a PFC is compensated by significant component cost reduction in the downstream converter.

The PFC also provides additional functions such as automatic mains voltage selection and a constant output voltage.

Nevertheless, size and cost optimization of PFC has to take the RFI filter section into account.

A PFC circuit generates more high frequency interferences to the mains than a conventional rectifier front-end section (see figure 5).

The PFC use requires thus additional filtering. For this reason, modulation techniques and mode of operation for the PFC have to be carefully adapted to the application requirement.

Figure 5: A Power Factor Converter generates higher frequency interferences to the mains than a conventional rectifier front-end

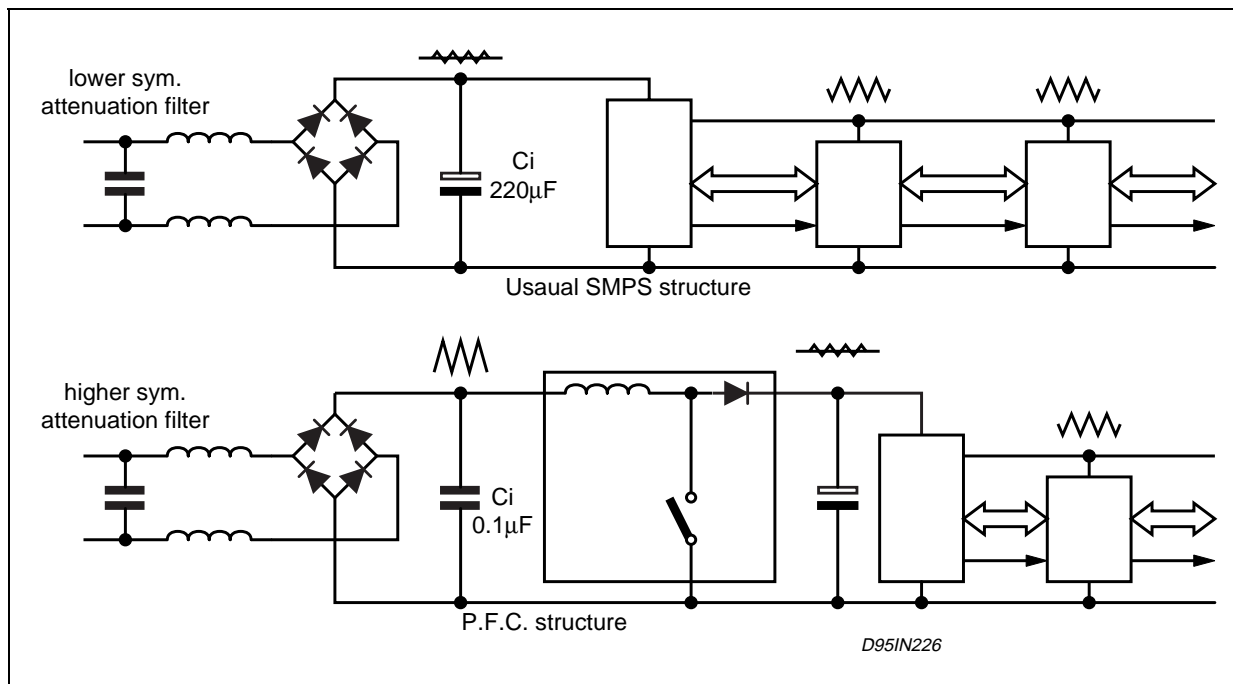

Information furnished is believed to be accurate and reliable. However, SGS-THOMSON Microelectronics assumes no responsibility for the consequences of use of such information nor for any infringement of patents or other rights of third parties which may result from its use. No license is granted by implication or otherwise under any patent or patent rights of SGS-THOMSON Microelectronics. Specifications mentioned in this publication are subject to change without notice. This publication supersedes and replaces all information previously supplied. SGS-THOMSON Microelectronics products are not authorized for use as critical components in life support devices or systems without express written approval of SGS-THOMSON Microelectronics.

© 1995 SGS-THOMSON Microelectronics - All Rights Reserved

SGS-THOMSON Microelectronics GROUP OF COMPANIES

Australia - Brazil - France - Germany - Hong Kong - Italy - Japan - Korea - Malaysia - Malta - Morocco - The Netherlands - Singapore - Spain - Sweden - Switzerland - Taiwan - Thailand - United Kingdom - U.S.A.



LittleDiode supplies new, hard to find or obsolete electronic components and semiconductors all over the world.

With over two million different components listed you are sure to find the part you need.

Feel free to visit us today at our online store:

LittleDiode.com

Looking forward to providing you with the best possible service.