

AN8212K

FDD Spindle Motor Controller

Overview

The AN8212K is an integrated circuit in which 300/360 rpm speed change-over function is added to the AN8210NK for FDD spindle motor.

Features

- Speed change-over built-in (300/360rpm)
- FG divider change-over built-in (1/1½)
- Speed control by digital velocity detector
- 3-phase full-wave current drive
- Motor current limit built-in
- Thermal protection built-in
- Start/stop switch

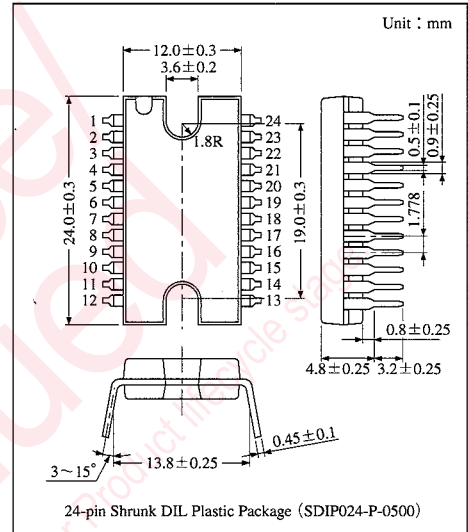

Block Diagram and Application Circuit

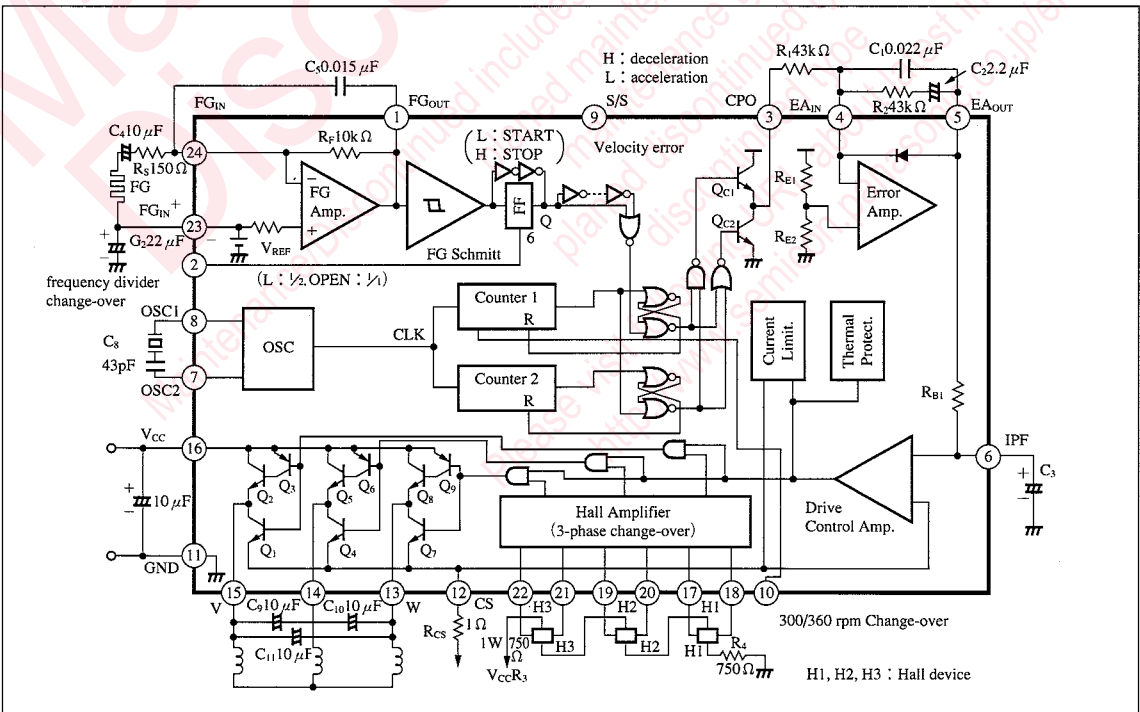

Pin Descriptions

Pin No.	Pin name	Pin No.	Pin name
1	FG amp. output	13	Motor drive output W
2	FG divider	14	Motor drive output U
3	Velocity error output	15	Motor drive output V
4	Error amp. inversion input	16	V _{CC}
5	Error amp. output	17	Hall amp. 1 +input
6	Low-pass filter	18	Hall amp. 1 -input
7	Oscillation circuit 2	19	Hall amp. 2 +input
8	Oscillation circuit 1	20	Hall amp. 2 -input
9	Start/stop switching	21	Hall amp. 3 -input
10	300/360 rpm switching	22	Hall amp. 3 +input
11	GND	23	FG amp. +input
12	Current sensing	24	FG amp. +input

Absolute Maximum Ratings (T_a = 25°C)

Parameter	Symbol	Rating	Unit
Supply voltage	V _{CC}	20	V
Motor drive pin voltage	V ₁₃ , V ₁₄ , V ₁₅	20	V
Pin applied voltage 1	V ₁ ~ V ₉ , V ₂₄	-0.3 to +5.5	V
Pin applied voltage 2	V ₁₇ ~ V ₂₂	0 to V _{CC}	V
Supply current	I _{CC}	900	mA
Pin current 1	I ₁₂	-900 to 0	mA
Motor drive pin current	I ₁₃ , I ₁₄ , I ₁₅	-900 to +900	mA
Pin current 2	I ₂₃	-20 to +1	mA
Power dissipation	P _D	2.5	W
Operating ambient temperature	T _{opr}	-20 to +75	°C
Storage temperature	T _{stg}	-55 to +150	°C

ICs for
Motor

Electrical Characteristics (V_{CC} = 12V, T_a = 25°C)

Parameter	Symbol	Condition	min	typ	max	Unit
Standby quiescent current	I _{QS}	V _{S/S} = 2V	—	0.3	0.5	mA
No-load quiescent current	I _{QN}	V _{S/S} = 0V	—	18	25	mA

Reference Voltage Part

Reference voltage	V _{OR}	I _{OR} = 0mA	2.3	—	2.8	V
Output sink current	I _{OR} ⁺		0.5	—	—	mA
Output source current	I _{OR} ⁻		—	-15	-10	mA
Output impedance	Z _{OR}	I _{OR} = 0 to -10mA	—	5	10	Ω

FG Amp./Schmitt Part

Offset voltage	V _{OSF}		-15	—	15	mV
Feedback resistance	R _{FF}		6.2	8.7	11.2	kΩ
Output sink current	I _{OF} ⁺	V _S = 0V, V _R = 3V	3	—	—	mA
Output source current	I _{OF} ⁻	V _S = 0V, V _R = 2V	—	—	-3	mA

Electrical Characteristics (Cont.) ($V_{CC}=12V$, $T_a=25^\circ C$)

Parameter	Symbol	Condition	min	typ	max	Unit
Speed Error Detect Part (Logic)						
Count switch-over voltage	V_{FG}		1.0	1.8	2.5	V
Count No. 1	N_{CT1}	300rpm mode	—	1006	—	Time
Count No. 2	N_{CT2}	300rpm mode	—	838	—	Time
Speed Error Output Part						
Output low voltage	V_{OLC}		—	0.1	0.3	V
Output high voltage	V_{OHC}		2.4	—	5.5	V
Output sink current	I_{OC}^+		300	—	—	μA
Output source current	I_{OC}^-		—	—	150	μA
Error Amp. Part						
Output sink current	I_{OE}^+		2	—	—	mA
Output source current	I_{OE}^-		—	—	-2	mA
Gain bandwidth product	f_{GBE}		—	800	—	kHz
FG divider change-over	—	$V_{FG}=0V$	—	600/720	—	rpm
300/360 rpm change-over	—	$V_{FG}=2.5V$	—	300/360	—	rpm
Drive Control Amp. Part						
Threshold voltage	V_{THD}		2.3	2.55	2.8	V
Drive gain	A_{GD}		1.6	1.8	2.0	Time
Limiter voltage	V_{LD}		0.59	0.66	0.72	V
Open loop drive gain	A_{OD}		—	30	—	dB
Hall Amp. Part						
Phase input voltage range	V_{ICH}		2	—	$V_{CC}-2$	V
Error input voltage range	V_{IDH}		—	—	400	mV
Hall input sensitivity	V_{ISH}		—	10	—	mV
Hall offset voltage	V_{OSH}		—	—	20	mV
Input bias current	I_{BH}		—	1.0	5.0	μA
Drive Output Part						
Saturation voltage (on V_{CC})	V_{SU}		—	—	1.4	V
Saturation voltage (on ground)	V_{SL}		—	—	1.1	V
OFF leak current	I_{LO}		-20	—	20	μA
Start/Stop Control Part						
Input low voltage	V_{IL}		—	—	0.7	V
Input high voltage	V_{IH}		2	—	—	V
Input low current	I_{IL}	$V_{S/S}=0V$	-100	-50	—	μA
Input high current	I_{IH}	$V_{S/S}=2V$	—	10	100	μA
Speed Error Output Part						
Output leak current	I_{LC}^*		—	—	0.1	μA
Input bias current	I_{BE}^*		—	—	0.1	μA
Quiescent breakdown level	V_s^*	Applied between GND and each pin ($C=100pF$, No R)	300	—	—	V

Note) Operating Supply Voltage Range : $V_{CC(opr)}=9$ to 16V

* These values are of reference values but not guaranteed values.

■ Characteristics Curve

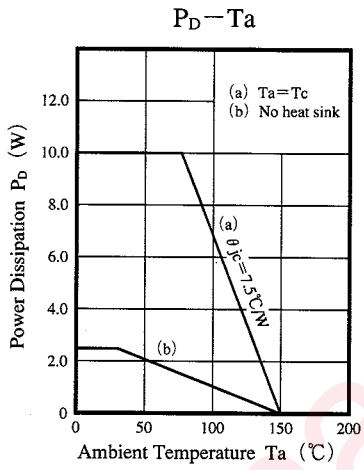

Maintenance/Discontinued includes following four Product lifecycle stage.
planned maintenance type
maintenance type
planned discontinued type
discontinued type
Please visit following URL about latest information.
<http://www.semicon.panasonic.co.jp/en/>



Request for your special attention and precautions in using the technical information and semiconductors described in this book

- (1) If any of the products or technical information described in this book is to be exported or provided to non-residents, the laws and regulations of the exporting country, especially, those with regard to security export control, must be observed.
- (2) The technical information described in this book is intended only to show the main characteristics and application circuit examples of the products. No license is granted in and to any intellectual property right or other right owned by Panasonic Corporation or any other company. Therefore, no responsibility is assumed by our company as to the infringement upon any such right owned by any other company which may arise as a result of the use of technical information described in this book.
- (3) The products described in this book are intended to be used for standard applications or general electronic equipment (such as office equipment, communications equipment, measuring instruments and household appliances).
Consult our sales staff in advance for information on the following applications:
 - Special applications (such as for airplanes, aerospace, automobiles, traffic control equipment, combustion equipment, life support systems and safety devices) in which exceptional quality and reliability are required, or if the failure or malfunction of the products may directly jeopardize life or harm the human body.
 - Any applications other than the standard applications intended.
- (4) The products and product specifications described in this book are subject to change without notice for modification and/or improvement. At the final stage of your design, purchasing, or use of the products, therefore, ask for the most up-to-date Product Standards in advance to make sure that the latest specifications satisfy your requirements.
- (5) When designing your equipment, comply with the range of absolute maximum rating and the guaranteed operating conditions (operating power supply voltage and operating environment etc.). Especially, please be careful not to exceed the range of absolute maximum rating on the transient state, such as power-on, power-off and mode-switching. Otherwise, we will not be liable for any defect which may arise later in your equipment.
 - Even when the products are used within the guaranteed values, take into the consideration of incidence of break down and failure mode, possible to occur to semiconductor products. Measures on the systems such as redundant design, arresting the spread of fire or preventing glitch are recommended in order to prevent physical injury, fire, social damages, for example, by using the products.
- (6) Comply with the instructions for use in order to prevent breakdown and characteristics change due to external factors (ESD, EOS, thermal stress and mechanical stress) at the time of handling, mounting or at customer's process. When using products for which damp-proof packing is required, satisfy the conditions, such as shelf life and the elapsed time since first opening the packages.
- (7) This book may be not reprinted or reproduced whether wholly or partially, without the prior written permission of our company.



LittleDiode supplies new, hard to find or obsolete electronic components and semiconductors all over the world.

With over two million different components listed you are sure to find the part you need.

Feel free to visit us today at our online store:

LittleDiode.com

Looking forward to providing you with the best possible service.