

Temperature Sensing Power MOSFET

Kandarp Pandya

INTRODUCTION

Vishay Siliconix temperature-sensing power MOSFETs promote reliability in end products by giving an additional means of protection to power circuitry from current overloads and excessive temperatures. The new devices work by using the falling forward voltage of on-chip diodes to detect increases in device temperature. This voltage is then fed into circuitry allowing the MOSFET to shut off power to the application if excessive temperature is detected.

DEVICE STRUCTURE

Vishay Siliconix temperature-sensing MOSFETs integrate an electrically isolated poly-silicon diode on the same die as the MOSFET (Figure 1). Because the MOSFET and the diode are so close together, the diode temperature tracks the MOSFET temperature. The forward voltage drop of the polysilicon diode is inversely proportional to its own junction temperature and by extension to the junction temperature of the MOSFET. Quantifying this, the temperature coefficient of the forward voltage drops is approximately $-2 \text{ mV}/^\circ\text{C}$. (Figure 2)

Figure 3 shows the data sheet specifications for a typical Vishay Siliconix temperature sensing power MOSFET. This particular device is packaged in a modified 5-pin D²PAK. Gate, drain, and source are located respectively on pins 1, 3, and 5.

The tab connected to pin 3 serves as the main drain connection. The temperature sensing diodes are terminated as T_1 and T_2 on pins 2 and 4 respectively. Schematically, the diodes, D_1 and D_2 are parallel connected. The electrical isolation of these diodes from main MOSFET facilitates non polarized biasing, eliminating the need for any level shifting in the control circuit even when the MOSFET is configured for high-side control.

Figure 4 shows basic specifications for the temperature sensing diode. The actual values of the temperature sensing diode's forward voltage drop depend on the forward biasing current. The sensing diode's forward voltage (V_{FD1} and V_{FD2}) ranges from a minimum of 675 mV to the maximum of 735 mV at the forward bias current (I_F) of 250 μA . This variation results from manufacturing tolerances. The forward voltage increase, ΔV_F , ranges from a minimum of 25 mV at $I_F = 125 \mu\text{A}$ to the maximum of 50 mV at $I_F = 250 \mu\text{A}$. This shows the effect of the bias current.

The cumulative effect can be seen in Figure 2, where sensing diode forward voltage is plotted against junction temperature. The forward bias current determines the operating line. The negative temperature co-efficient of forward voltage drop is evident from the slope of the characteristics. The diode drop varies along this line in accordance with the MOSFET junction temperature.

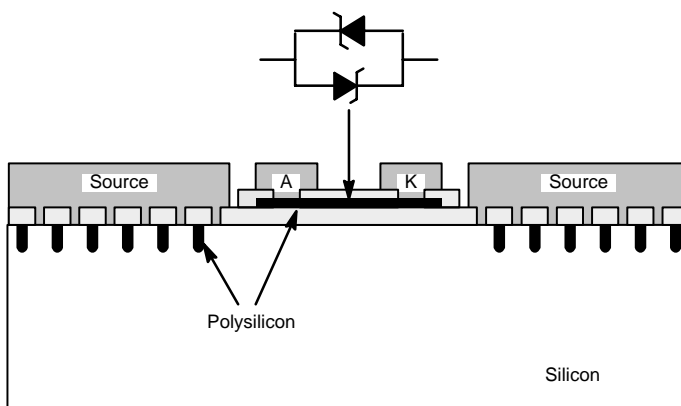

FIGURE 1. Structure of a Temperature Sensing Power MOSFET

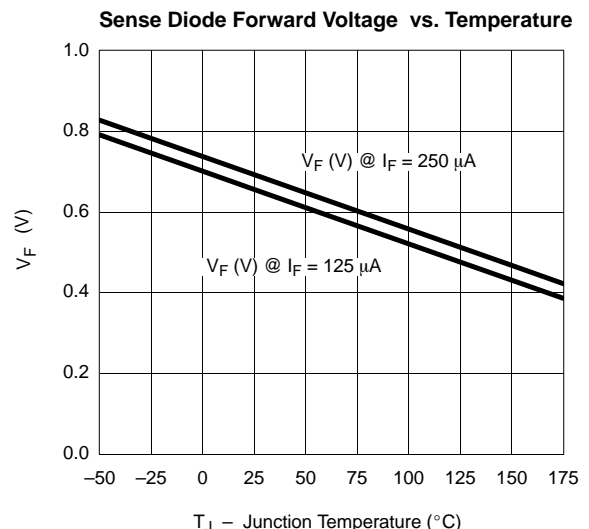

FIGURE 2.

PRODUCT SUMMARY		
$V_{(BR)DSS}$ (V)	$r_{DS(on)}$ (Ω)	I_D (A)
20	0.012 @ $V_{GS} = 10$ V	60 ^a
	0.015 @ $V_{GS} = 4.5$ V	60

Notes:
a. Package limited.

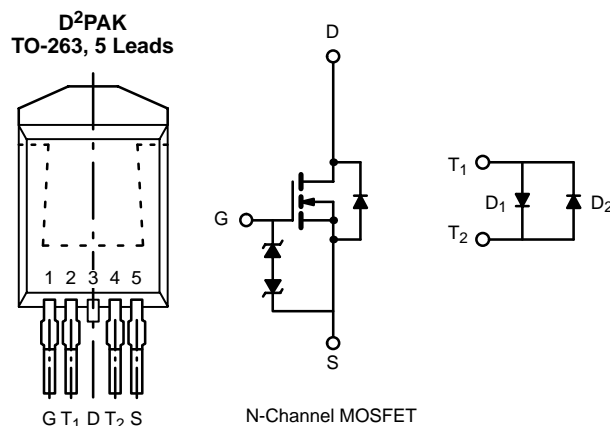

FIGURE 3. Basic Specifications

MOSFET SPECIFICATIONS ($T_J = 25^\circ\text{C}$ UNLESS OTHERWISE NOTED)						
Parameter	Symbol	Test Condition	Min	Typ	Max	Unit
Static						
Sense Diode Forward Voltage	V_{FD1}	$I_F = 250 \mu\text{A}$	675		735	mV
	V_{FD2}	$I_F = 250 \mu\text{A}$	675		735	
Sense Diode Forward Voltage Increase	ΔV_F	From $I_F = 125 \mu\text{A}$ to $I_F = 250 \mu\text{A}$	25		50	
Forward Transconductance ^{NO TAG}	g_{fs}	$V_{DS} = 15$ V, $I_D = 20$ A		35		S

FIGURE 4. Sense Diode Specifications

DESIGN EXAMPLE

In the following design example, a simple comparator circuit utilizes the diode's forward voltage drop to sense the MOSFET junction temperature and implement self-protection of the

MOSFET against overtemperature in a control circuit. Figure 5 is a load switch controlling a floating load on the high side using the SUB60N04-15LT temperature-sensing power MOSFET.

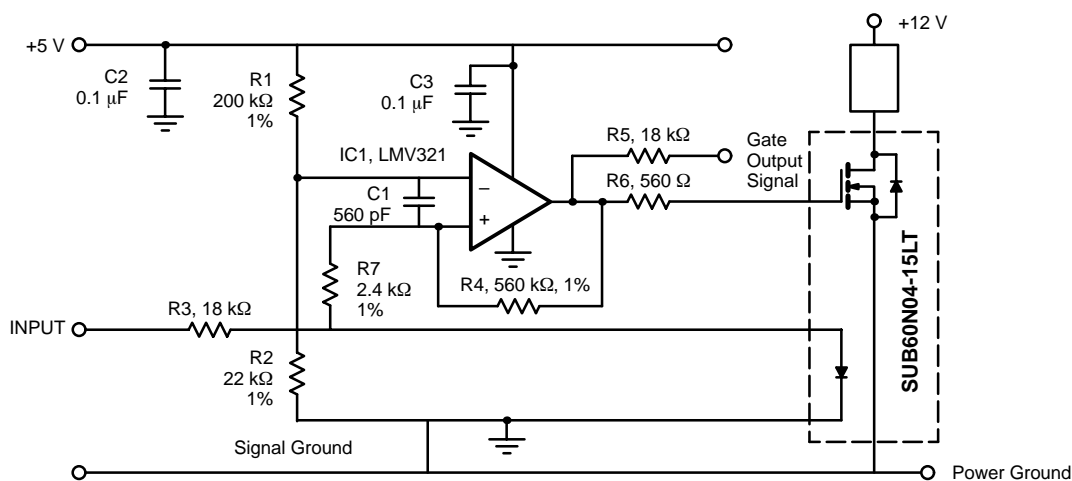

FIGURE 5. Schematic Diagram



Design Criteria used are as follows:

(a) Functional requirements

- 5-V logic-level signal at the input terminal biases the polysilicon diode with $I_F = 250 \mu\text{A}$ and turns on the MOSFET
- Protection circuit turns off the MOSFET before its junction temperature reaches maximum permitted limit of 175°C
- Protection circuit enables cyclic turn-on and turn-off under continuous overload or short circuit conditions, without allowing the junction temperature to exceed the maximum permissible limit

(b) Assumptions

- 5-V logic-level power supply (V_{LL}) for the control circuit is independent of overload or shorted load on the MOSFET side
- Power supply source on load side is capable of supplying continuous overload/short circuit current
- The conducting paths on the PC board, around the load, and the power supply are capable of carrying short circuit currents

The basic circuit configuration is the same for any Vishay Siliconix temperature sensing power MOSFET. However, to obtain the desired trip points, the values of the following components must be selected and or calculated:

- Resistor R_3 to set the poly-diode bias current
- Resistors R_4 and R_7 to set the hysteresis voltage
- Resistors R_1 and R_2 to set the reference voltage

Design calculations (Refer to Figure 5):

Step 1

Select the polysilicon diode bias current: $I_F = 250 \mu\text{A}$

Step 2

Resistor R_3 establishes the polysilicon diode bias current as follows:

$$\begin{aligned} R_3 &= (V_{LL} - V_F @ 25^\circ\text{C}) / I_F \\ &= (5 \text{ V} - 0.7 \text{ V}) / 250 \mu\text{A} \\ &= 18 \text{ k}\Omega \end{aligned}$$

Step 3

Select temperature hysteresis: 10°C

A temperature coefficient of $-2 \text{ mV}/^\circ\text{C}$ translates into a voltage hysteresis of $V_{HYS} = 20 \text{ mV}$. This is adequate to ensure jitter free, snap-action turn-on and turn-off of the power MOSFET.

Step 4

Calculate values of resistors R_4 and R_7 using the following equation:

$$V_{HYS} = [R_7 / (R_7 + R_4)] \times V_{OUT}$$

When the op-amp output is high, $V_{OUT} = 4.8 \text{ V}$

Hence,

$$\begin{aligned} [R_7 / (R_7 + R_4)] &= V_{HYS} / V_{OUT} \\ &= 20 \text{ mV} / 4.8 \text{ V} \end{aligned}$$

By selecting a value of $560\text{-k}\Omega$ for resistor R_4 , we ensure that less than $10 \mu\text{A}$ is used in the feedback loop and most of the op-amp output current is available for the gate drive.

Substituting the value of resistor R_4 in the equation

$$[R_7 / (R_7 + R_4)] = 20 \text{ mV} / 4.8 \text{ V}$$

$$[R_7 / (R_7 + 560 \text{ k}\Omega)] = 20 \text{ mV} / 4.8 \text{ V}$$

resistor $R_7 = 2.4 \text{ k}\Omega$

When op-amp output is low

$$\begin{aligned} V_{HYS} &= [R_7 / (R_7 + R_4)] \times V_{OUT} \\ &= [2.4 \text{ k}\Omega / (2.4 \text{ k}\Omega + 560 \text{ k}\Omega)] \times <0.2 \text{ V} \\ &= <1 \text{ mV, negligible.} \end{aligned}$$

Step 5

Determine reference voltage V_{REF} .

The V_{REF} sets the trip point used by the op-amp comparator. Select the maximum trip temperature $T_J = 170^\circ\text{C}$, which is less than 175°C , the maximum temperature rating of the device.

As shown in Figure 6, now create new set of curves for maximum and minimum V_{FD} vs. T_J and $V_{FD} + V_{HYS}$ vs. T_J using the following datasheet information:

Use the slope of the curve V_{FD} vs. T_J at $I_F = 250 \mu\text{A}$ (Figure 2).

Use the maximum and the minimum values of V_{FD} at $I_F = 250 \mu\text{A}$ (Figure 4).

Superimpose the value of hysteresis voltage, $V_{HYS} = 20 \text{ mV}$ from Step 3, to create the curves for $V_{FD(max)} + V_{HYS}$ vs. T_J and $V_{FD(min)} + V_{HYS}$ vs. T_J . (Figure 6).

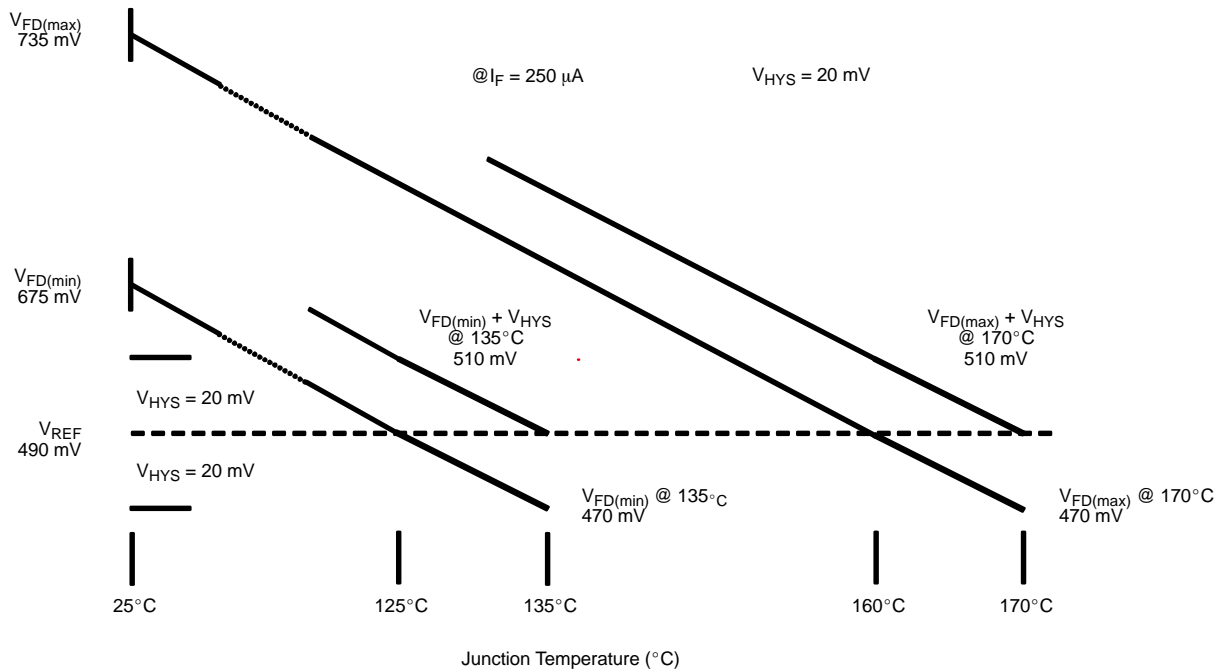

FIGURE 6. Maximum and Minimum V_{FD} vs. T_J and Maximum and Minimum $V_{FD} + V_{HYS}$ Curves

To ensure that maximum trip temperature equals 170°C, determine the voltage where $V_{FD(max)} + V_{HYS}$ intersects 170°C in Figure 6. This is the value of the reference voltage, $V_{REF} = 490$ mV. Also determine the temperature where $V_{FD(min)} + V_{HYS}$ intersects V_{REF} . This is the minimum trip temperature, or 135°C.

The following equation defines the value of the voltage divider components, resistors R_1 and R_2 :

$$V_{REF} = [V_{CC} / (R_1 + R_2)] \times R_2$$

Hence,

$$(R_1 + R_2) / R_2 = V_{CC} / V_{REF} \\ = 5 \text{ V} / 490 \text{ mV}$$

Now select the resistor $R_1 = 200$ k Ω

Substituting the value of R_1 in the above equation, resistor $R_2 = 22$ k Ω

Step 6

The value of resistor $R_5 = 18$ k Ω is selected to facilitate monitoring of gate output signal without loading the op-amp output. The value of resistor $R_6 = 560$ Ω ensures adequate gate current. More importantly, R_6 provides isolation between the MOSFET and the op-amp in case of catastrophic failure from either side.

Step 7

The values of capacitors C_1 , C_2 , and C_3 are chosen to provide necessary noise immunity.

CIRCUIT OPERATION

Let us assume that the forward voltage drop for the device in use is at the maximum value, i.e., $V_{FD(max)} = 735$ mV at 25°C and $I_F = 250$ μ A.

(a) Normal Condition

(i) MOSFET "OFF"

The logic-level low at the input can't bias the sense diode adequately. The resulting forward diode voltage drop, V_{FD} , is much lower than the reference voltage $V_{REF} = 490$ mV, established by voltage divider resistors R_1 and R_2 . The op-amp output remains low. The gate drive is not available for the MOSFET, which remains in the off state.

(ii) MOSFET "ON"

The logic-level high, i.e. 5 V at the input, provides a bias current of $I_F = 250$ μ A for the sense diode through resistor R_3 . Under normal conditions, the resulting V_{FD} is greater than V_{REF} . The op-amp output switches to high state, i.e. $V_{OUT} = 4.8$ V. This is the logic level gate drive to turn on the MOSFET.

In addition, the 4.8 V on the op-amp output provides a hysteresis voltage $V_{HYS} = 20$ mV, by means of positive feedback derived through resistors R_4 and R_7 . The signal at the non-inverting, '+' input of the op-amp is a superposition of $V_{FD(max)}$ and V_{HYS} . Thus the op-amp compares V_{REF} against $V_{FD(max)} + V_{HYS}$.

(b) Fault Condition

The fault condition arises only when the MOSFET is on, and when any one or more of the following conditions are present: (1) overload, (2) short-circuited load, (3) overvoltage, or (4) inadequate gate drive. The MOSFET junction and sense diode temperature rise. $V_{FD(max)}$ drops with the rise in the diode/MOSFET junction temperatures. Effectively, the voltage at the non-inverting, '+' input of the op-amp, $V_{FD(max)} + V_{HYS}$, drops (Figure 7). The op-amp output switches to the low state when $V_{FD(max)} + V_{HYS}$ drops below V_{REF} . The MOSFET switches off before its junction temperature exceeds the rated temperature of 175°C.

(c) Cyclical operation under fault conditions

Now, with MOSFET turned off, the V_{HYS} is removed. The operation shifts from the $V_{FD(max)} + V_{HYS}$ curve to the $V_{FD(max)}$ curve only (Figure 7). This shift ensures jitter free turn-off as the $V_{REF} = 490$ mV is now compared with only $V_{FD(max)} =$

470 mV at $T_J = 170^\circ\text{C}$. Since there is no current flow, the MOSFET die cools down, the diode temperature starts dropping back towards ambient, and the voltage $V_{FD(max)}$ rises from 470 mV. When $V_{FD(max)} = V_{REF} = 490$ mV at $T_J = 160^\circ\text{C}$, the MOSFET turns on again. The operation shifts from $V_{FD(max)}$ to the $V_{FD(max)} + V_{HYS}$ path. Again, the shift results from addition of the hysteresis voltage and provides jitter free turn-on. This time $V_{HYS} = 20$ mV is added to $V_{FD(max)} = 490$ mV. Now the $V_{REF} = 490$ mV is compared with $V_{FD(max)} + V_{HYS} = 490 + 20 = 510$ mV. The prevailing fault condition leads to a rise in junction temperature and voltage drop in $V_{FD(max)} + V_{HYS}$. The cycle repeats as long as the fault condition exists.

Cyclical operation under fault conditions is highlighted with arrow-headed traces in Figure 7.

Two sets of curves describe the difference in the circuit behavior with respect to tripping temperatures for a given device. Thus a device with maximum possible V_{FD} of 735 mV at 25°C will cycle between 170°C and 160°C respectively for MOSFET turn-off and turn-on as described above. A device with a minimum possible V_{FD} of 675 mV at 25°C will cycle between 135°C and 125°C.

In this manner, the self-protecting feature remains active during fault conditions over the entire tolerance range of the part. This is the most important capability of the circuit for a successful application.

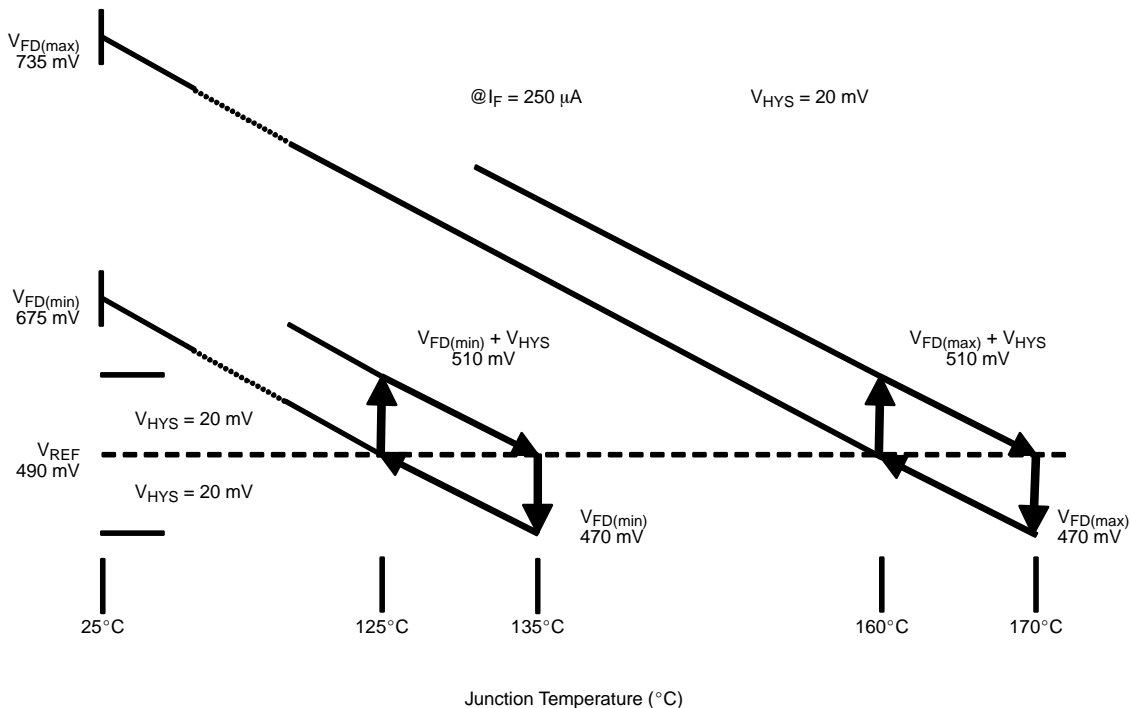

FIGURE 7. Cyclical Operation Under Fault Condition

APPENDIX A: BILL-OF-MATERIAL

Item	Qty	Designator	Part Type	Description	Footprint	Part Number	Manufacturer
1	1	R ₁	200 kΩ	Resistor, 0.1 W, 1%	805	CRCW08052003F	Vishay Dale
2	1	R ₂	22 kΩ	Resistor, 0.1 W, 1%	805	CRCW08052202F	Vishay Dale
3	2	R ₃ , R ₅	18 kΩ	Resistor, 0.1 W, 5%	805	CRCW0805183J	Vishay Dale
4	1	R ₄	560 kΩ	Resistor, 0.1 W, 1%	805	CRCW0805564F	Vishay Dale
5	1	R ₆	560 Ω	Resistor, 0.1 W, 5%	805	CRCW0805561J	Vishay Dale
6	1	R ₇	2.4 kΩ	Resistor, 0.1 W, 1%	805	CRCW0805242F	Vishay Dale
7	1	C ₁	560 pF	Capacitor, Ceramic, 25 V	805	VJ0805Y561JXAA	Vishay Vitramon
8	2	C ₂ , C ₃	0.1 μF	Capacitor, Ceramic, 25 V	805	VJ0805Y104JXAA	Vishay Vitramon
9	1	Q ₁	40 V	Temperature Sense MOSFET	D ² PAK	SUB60N04-15LT	Vishay Siliconix
10	1	U ₁	LMV321M5	IC, Low Voltage Op Amp	SC70-5		Multi-Source

APPENDIX B: VISHAY SILICONIX TEMPERATURE SENSING POWER MOSFETS

Device Number	Gender	Breakdown Voltage (V)	Maximum On-Resistance (mΩ)	Maximum I _D (A)	Package
SUB60N04-15LT	N-Channel	40	15	60	D ² PAK
SUB50N04-07LT	N-Channel	40	7	50	D ² PAK
SUB50P05-13LT	P-Channel	50	13	50	D ² PAK
SUC75N04-04T	N-Channel	30	4	75	Die Form

Note: For current products visit the Vishay website.



LittleDiode supplies new, hard to find or obsolete electronic components and semiconductors all over the world.

With over two million different components listed you are sure to find the part you need.

Feel free to visit us today at our online store:

LittleDiode.com

Looking forward to providing you with the best possible service.