V.17 FAX EQUIPMENT REPLACING THE R144EFX WITH THE ST75C52/520

By Laurent CLARAMOND and Joël HULOUX

SUMMARY		Page
I	PRELIMINARY	2
II	INTRODUCTION	2
II.1	OVERALL	2
II.2	A FEW MODIFICATIONS IN THE SOFTWARE	2
II.3	HARDWARE EVOLUTIONS	2
III	COMPARISON BETWEEN R144EFX AND ST75C52/520	3
IV	FEATURES REQUIRED FOR FAX COMMUNICATIONS	4
V	DATA SHEET AND USER'S MANUAL GUIDE LINE	4
VI	SOFTWARE GUIDE LINE	4
VI.1	USER INTERFACE	5
VI.2	INTERRUPTIONS	5
VI.3	PARALLEL EXCHANGE IN SYNCHRONOUS AND IN HDLC MODE	7
VI.4	STATUS REPORT	8
VI.5	G3 FAX EQUIPMENT	8
VII	FLAG DETECTION	9
VII.1	V.21 CHANNEL 2 FLAG 7E DETECTION	9
VII.2	FLAG DETECTION IN V.21 CHANNEL 2 MODE	9
VII.3	FLAG DETECTION IN HIGH SPEED MODE	9
VII.3.1	Flag Detection at the Beginning of C Phase or TCF Reception	9
VII.3.2	Flag Detection in C Phase	10
VIII	EQUALIZER AT RECEPTION SIDE	11
IX	HOW TO ADJUST THE TRANSMIT LEVEL	12
X	HARDWARE GUIDE LINE	12

V.17 FAX EQUIPMENT REPLACING THE R144EFX

I - PRELIMINARY

The ST75C52/520 are a monolithic complete V.17 fax modem which is a superset of the R144EFX.

All functions found in the R144EFX can be found in the ST75C52/520, plus a few additional ones (class detection, 16 tone detectors, analog DAC for eyedagram, etc) as you will see in the chapter III table.

Although similar, the ST75C52/520 are not a plug-in replacement for R144EFX. You will need a few software and hardware adjustments, and with our help, it will cost you less than two man-months to do it.

A small effort, compared to your benefits. If you are thinking about integrating the ST75C52/520 with your preferred MCU and ASIC, call us immediately.

II - INTRODUCTION

II.1 - Overall

This application note describes the way to replace the ROCKWELL R144EFX by the SGS-THOMSON ST75C52/520 in a V.17 FAX equipment system.

This application note uses information detailed in the ST75C52/520 Data Sheet and User's Manual.

First, you will find comparison on the features of the ST75C52/520 and the R144EFX.

Second, will be listed the features required to implement FAX communications.

Third, will be presented to the user the different chapters in the ST75C52/520 and User's manual where information was detailed.

At the end of this application note is presented a software and hardware user's guide.

II.2 - A Few Modifications in the Software

The user's fax software can be divided in two parts. The first part which is *the main* and *the biggest* is completely independent of the modem chip and is in charge of the following task :

- User interface (keyboard, screen, printer).

- ECM, T30, T4.
- Real time kernel.
- Control.

- ...

Layers 2 and 3 are in this part of the software.

This software can be reused in the final application without any modification and any perturbation when running in V.17 fax equipment including a ST75C52/520 modem chip.

The second part (which is *the smallest*) is dependent of the modem chip and includes the driver routines needed to provide a complete list of services to the layer 2 and 3. We mainly find the following drivers :

- Interrupts driver.
- Modem configuration.
- Data transfer (emission/reception).
- Tone detection/generation.

All the modifications will be easily done since :

- **the ST75C52/520's software interface is based on COMMAND SET using friendly mnemonics,**
- **interrupts use dedicated registers clearly identified,**
- **data transfer will use FIFO principle to save CPU time.**

II.3 - Hardware Evolutions

Performances and low cost are the *two key parameters* that have been followed by SGS-THOMSON.

The user can to remove the negative power supply (-5V) since the ST75C52/520 needs only one power supply of +5V. The differential analog output and input will increase performances at low level even on a two-layer printed circuit board. EMI problems can be reduced using a crystal of 29.4912MHz instead 38.00053MHz.

V.17 FAX EQUIPMENT REPLACING THE R144EFX

III - COMPARISON BETWEEN R144EFX AND ST75C52/520

Features	R144EFX	ST75C52/520
Package	QUIP 64 and PLCC68	PQFP64
Power	+5V ±5%, -5V ±5%	+5V ±5%
Supply Current at 25°C	97mA and 14mA (555mW)	100mA (500mW, 5mW low power mode)
Supply Current at 0°C	105mA and 16mA (605mW)	130mA (650mW)
Operating Range	0 to 70°C	0 to 70°C
Storage Temperature	-55 to 125°C	-45° to 125°C
Frequency	38.000530MHz	29.4912MHz
MCU Bus	65XX/80XX bus	MOTOROLA, INTEL bus
Interface with DSP	32 registers	60 registers
Interrupts	2 interrupts, one can be activated with a selectif mask from one of the 32 registers	One interrupt. Six sources with possible individual mask
Serial Interface	YES	YES
TX Buffer	1 byte	2 x 8 bytes
RX Buffer	1 byte	2 x 8 bytes
FAX Group 3	V.33 (14.4, 12kbps, 17000 and 1800Hz) idem V.17 V.17 (14.4, 12, 9.6, 7.2kbps, 1700 and 1800Hz) with short train V.29 (9.6, 7.2, 4.8kbps), no short train V.27ter (4.8, 2.4kbps) with short train	V.33 (14.4, 12kbps, 17000 and 1800Hz) idem V.17 V.17 (14.4, 12, 9.6, 7.2kbps, 1700 and 1800Hz) with short train V.29 (9.6, 7.2, 4.8kbps), with short train V.27ter (4.8, 2.4kbps) withshort train
Short Train	V.27ter, V.17	V.27ter, V.29, V.17
HDLC	YES	YES
TX Level	0 to -15dBm	0 to -48dBm
Dynamic Range	0 to -43dBm	0 to -43dBm
Turn On	-10 to -47dBm	-10 to -51dBm
Turn Off	-10 to -52dBm	-15 to -55dBm
Reception Timing	±0.01% frequency error	±0.01% frequency error
Tone Generator	2 from 0 to 4800Hz (step 0.15Hz), attenuation if f > 300Hz	4 from 0 to 3600Hz (step 1Hz)
DTMF Generation	Uses the 2 generators	Uses 2 of the 4 generators
Tone Detector	FR1, FR2 and FR3 from 400 to 3000Hz (FR1 and FR2 not available in high speed reception)	2 to 16 detectors programmable from 0 to 3600Hz : 2 if training FAX high speed reception, else 8, 4 if DTMF detection, 16 if tone reception or audio transmission and reception
DTMF Detection	Gives the DTMF digit. Twist (-8 to +4dB)	Gives the DTMF digit. Threshold -35dBm. T _{on} > 40ms, Twist (±8dB)
Flag Detection	Available in high speed reception except in V.27 ter short train and tone detection	Available in high speed reception, and tone detection mode
Voice Mode	7.2, 8 and 9.6kHz on 8 bits till 10 to 16 bits	7.2, 8 and 9.6kHz. A law on 8 bits
Equalizers (Transmission and Reception)	4	4
Input/Output	NO	NO
V.23 (Full Duplex)	NO	YES
Eye Monitoring	Yes with serial link	Yes with analog output
Analog Interface	Mono	Differential
Max Output Level	±3.3V	±2.5V
Max Input Level	0dBm at RXA	±2.5V
Bell 103-V.21 Full Duplex	NO	YES
Class Detection	NO	YES

V.17 FAX EQUIPMENT REPLACING THE R144EFX

IV - FEATURES REQUIRED FOR FAX COMMUNICATIONS

In phase A (T.30 protocol) the modem chip must provide all features to establish or to answer a call. The user will use Tone Detectors for network tones detection (dialtone, busy tone, ring back tone), for answer tone detection (CED 2100Hz tone) and for flag detection.

In the calling unit, tone generators will be used to send DTMF digit, and the calling tone (CNG tone at 1100Hz).

When on-hook, the modem chip can help the host make incoming call detection.

In phase B, D and E (T.30 protocol) the modem chip must be able to send or receive :

- In V.21 ch2,
- HDLC frame over V.21 ch2 modulation,
- TCF frame in high speed mode (only in phase B).

In phase C the chip must be able to send or receive in high speed mode (V.27ter, V.29, V.17), and to detect V.21 flag (HDLC fanion) while in high speed mode reception.

The user must be able to adjust level in transmission (carrier, tone).

Complete HDLC (transmit and receive) function must also be available in high speed mode to allow ECM (Error Correcting Mode).

Some others features such as DTMF detection, voice mode may be required in the final application.

To use all the above features the user will initialize registers in the DSP and must read status. So, the chip must provide a friendly interface to a host microprocessor.

All the above features included in the R144EFX can be easily used with the ST75C52/520.

V - DATA SHEET AND USER'S MANUAL GUIDE LINE

Firstly the user has to read carefully the ST75C52/520 Data Sheet and User's Manual.

Secondly the user can use the following list which identifies the main chapters in the ST75C52/520 documentation. These chapters detail the features introduced in the previous chapter.

Digital Interface :

- Data Sheet Chapter III
- User's Manual Chapter II.2

User Interface :

- Data Sheet Chapter V

Analog Interface :

- Data Sheet Chapter XII
- User's Manual Chapter VIII

Tone Generator :

- Data Sheet Chapter IV.2.4
- Data Sheet Chapter VI :
- DEFT, Tone, TGEN commands

Tone Detector :

- Data Sheet Chapter VIII
- User's Manual Chapter V

Interruptions :

- Data Sheet Chapter V.I.2

Configuration for G3 FAX :

- Data Sheet Chapter VI :
- HSHK, SYNC, CONF, MODC commands
- Data Sheet Chapter VII
- User's Manual Chapter VII

HDLC Function :

- Data Sheet Chapter VI
- FORM, SERIAL commands
- Data Sheet Chapter IX
- User's Manual Chapter IV

Control in Transmit Mode :

- User's Manual Chapter VI

Control in Receive Mode :

- User's Manual Chapter VII

PCB Guide Line :

- User's Manual Chapter IX

VI - SOFTWARE GUIDE LINE

As the main differences between the R144EFX and the ST75C52/520 are found in the software management, we suggest to the user the following steps to understand the ST75C52/520 software interface :

1. Study the User interface, the Command set, the Command Acknowledge.
2. Study the interruptions features.
3. Study the Parallel exchange in synchronous and in HDLC mode.
4. Study the status report.
5. Study the flow charts for G3 FAX configuration.

V.17 FAX EQUIPMENT REPLACING THE R144EFX

VI.1 - User Interface

The host processor will be connected to the ST75C52/520 using a dual port ram with dedicated memory addresses for :

- Command and Parameters,
- Command Acknowledge,
- Data Tx buffer (transmission),
- Data Rx buffer (reception),
- Status information,
- Interrupt registers.

The address space within the host RAM mapping is a 128 byte block requiring 7 address lines instead 5 for the RFX144EFX.

The host processor will use commands (with or without parameters) to initialize the modem chip and to start/stop a specific task such as : send a tone, a carrier or detect a tone, a DTMF, a carrier, ...

Hereafter is described the syntax for each command :

Opcode : Hexadecimal Value

X	X	X	X	X	X	X	X
---	---	---	---	---	---	---	---

Parameters :

Field	Byte	Pos	Value	Definition
Name	X	a..b	XX*	Explanation of the parameter

Field : Name of the addressed bit field.

Byte : Index of the parameter byte (1 to 4).

Pos : Bit field position inside the parameter byte.

Value : Possible values for the bit (resp. bit field).
A value followed by a star means a default value.

Each command will be acknowledged by the DSP. The host processor must not send a new command without waiting for the acknowledgment of the previous command.

Figure 1 summarizes the command acknowledgment.

VI.2 - Interruptions

Six sources of interruptions can be used by the software handler routine :

- Error : IT0, if errors have occurred
- Tx Buffer : IT2, the ST75C52/520 frees one of the 2 Tx buffers
- Rx Buffer : IT3, the ST75C52/520 has filled one of the 2 Rx buffers
- Status byte : IT4 to signify that the modem status has changed
- Low power mode : IT5 when the ST75C52/520 has been awakened
- Command acknowledge : IT6, the ST75C52/520 is ready for a new command

One 8 bit source register **ITSRCR** located at address **\$50** in the dual port ram memory identifies the source :

- D0 = 1 IT0 pending
- D1 Not used
- D2 = 1 IT2 pending
- D3 = 1 IT3 pending
- D4 = 1 IT4 pending
- D5 = 1 IT5 pending
- D6 = 1 IT6 pending

Figure 1

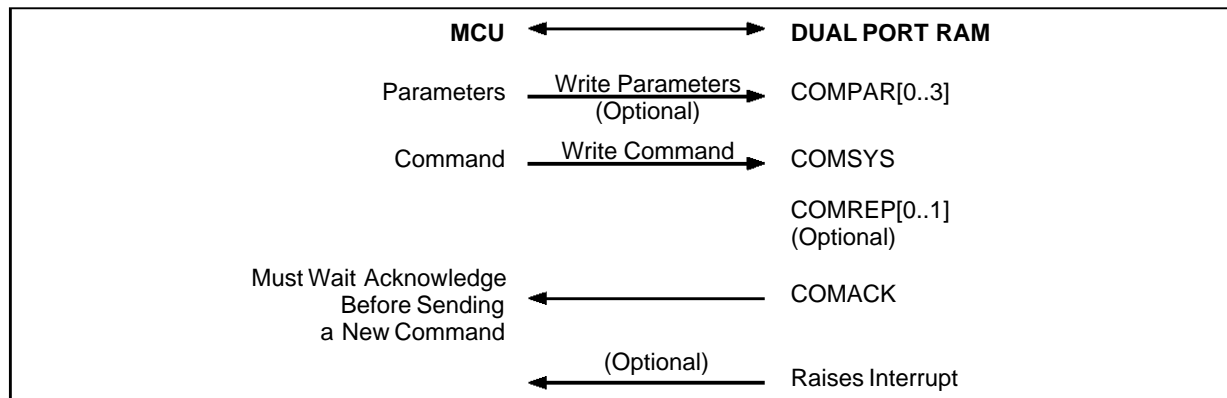

AN814-01.EPS

V.17 FAX EQUIPMENT REPLACING THE R144EFX

The interrupt source will be reset and acknowledge by writing a \$00 at one of the memory location \$40 to \$46 (Reset Interrupt registers **ITREST[0..6]**) in the dual port ram memory.

ITREST[0] at address \$40 is dedicated to IT0.

ITREST[2] at address \$42 is dedicated to IT2.

...

ITREST[6] at address \$46 is dedicated to IT6.

Figure 2 is an example for IT2.

All sources of interrupt can be masked individually or globally with the interrupt mask register **ITMASK** located at the address \$4F in the dual port ram memory.

ITMASK register definition :

D7 = 0 All interrupts are masked
(global mask)

D6 = D7 = 1 IT6 enable

D5 = D7 = 1 IT5 enable

D4 = D7 = 1 IT4 enable

D3 = D7 = 1 IT3 enable

D2 = D7 = 1 IT2 enable

D1 Not used must be equal to 0

D0 = D7 = 1 IT0 enable

Even if an interrupt is masked, the DSP will always set the corresponding bit in the source register (ITSRCR) to allow polling by the host processor.

Figure 3 illustrates for IT2 and IT3 the interruption principle, the user could easily transpose this principle to the other interrupts :

- IT2 and IT3 are set by the DSP,
- IT2 and IT3 are cleared and acknowledged by the host processor,
- ITSRCR is only read by the host processor,
- ITMASK is read or write by the host processor.

Figure 2

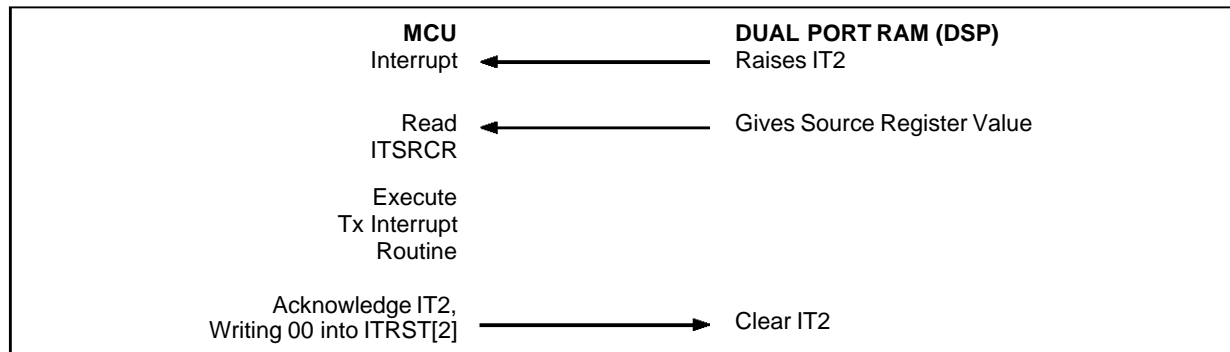
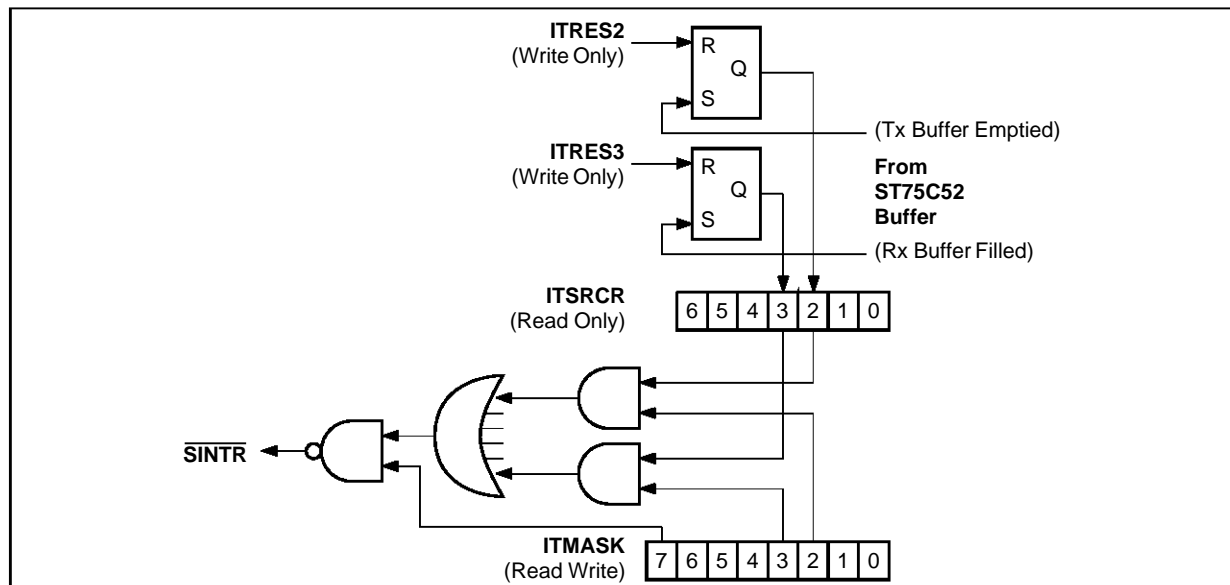

Figure 3



VI.3 - Parallel Exchange in Synchronous and in HDLC Mode

Data Tx Buffer :

The R144EFX uses only *one* TX buffer of *one* byte in parallel transmission. This architecture is very simple since the DSP has to write successive bytes at the same address. The drawback is that the R144EFX will raise an interrupt *every* sent byte.

To save MCU (host processor) time the principle is quite different with a ST75C52/520.

Two Tx buffers will be used in parallel transfer, TX_BUFFER_0 called **DTTBF0** and TX_BUFFER_1 called **DTTBF1**. Each Tx buffer contains 8 bytes. The host processor can write one to eight bytes in the same buffer.

The Tx interrupt (IT2) will only be raised when the complet TX buffer will be empty (e.g for TX buffers filled with 8 bytes the IT2 will be activated every 8 bytes). As this principle save MCU time between two interrupts, the host processor could be more efficiency used for other main tasks such as Error Correcting Mode (ECM), ...

One status byte **DTTBS0** is dedicated to DTTBF0 and another **DTTBS1** is associated with DTTBF1.

Parallel transmission must be initialized with **SE-RIAL**, **FORM** and **XMIT** commands. In parallel transmission the two buffers *must* be used, *always* starting with buffer 0. The host processor must

send data alternatively into DTTBF0, DTTBF1, DTTBF0, DTTBF1, DTTBF0, ...

The host processor writes data into a Tx buffer then writes the number of bytes into the dedicated status. The DSP reads the Tx buffer and clears the dedicated status, then raises IT2.

Figure 4 is illustrated the exchange in transmit parallel mode (initialization with the FORM, SERIAL and XMIT was already done).

Complet and detailed information is given in chapter IV of the ST75C52/520 User's Manual.

Data Rx Buffers :

The R144EFX uses only *one* RX buffer of *one* byte in parallel reception. This architecture is very simple since the DSP has to read successive bytes at the same address. The drawback is that the R144EFX will raise an interrupt *every* received byte.

To save MCU (host processor) time the principle is quite different with a ST75C52/520.

Two RX buffers will be used in parallel transfer, RX_BUFFER_0 called **DTRBF0** and RX_BUFFER_1 called **DTRBF1**. Each Rx buffer contains 8 bytes. The host processor will generally read eight bytes in the same buffer except if the modem chip detects a loss of carrier.

One status byte **DTRBS0** is dedicated to DTRBF0, and another **DTRBS1** is dedicated to DTRBF1.

Figure 4 : Data Tx Buffer Flow Chart

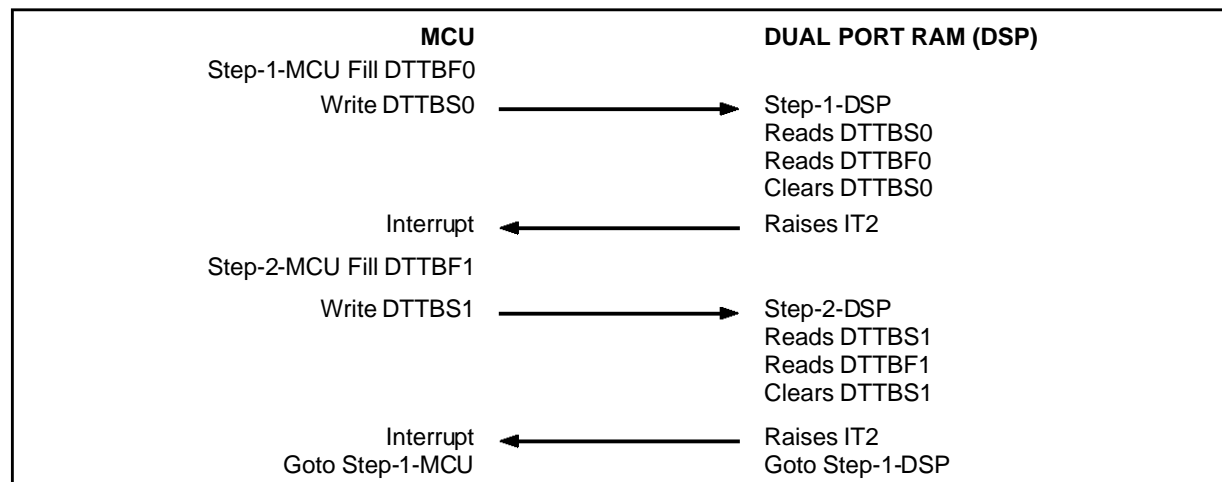

AN814-04.EPS

V.17 FAX EQUIPMENT REPLACING THE R144EFX

The Rx interrupt (IT3) will only be raised when the complet RX buffer will be full (IT3 will be activated every 8 bytes). As this principle saves MCU time between two interrupts, the host processor could be more efficiency used for other main tasks such as ECM, ...

Parallel reception must be initialized with SERIAL and FORM commands.

In parallel reception the two buffers must always be used, starting with buffer 0. The DSP will alternatively fill DTRBF0, DTRBF1, DTRBF0, DTRBF1, ...

The DSP will fill one Rx buffer, then fill the dedicated status register and then raises IT3.

Each time an Rx buffer is filled the host processor must read it and then clear the dedicated status register.

Figure 5 is illustrated the exchange in receive parallel mode (initialization with the FORM, SERIAL already done).

Complet and detailed information is given in chapter IV of the ST75C52/520 User's manual.

VI.4 - Status Report

The host processor needs some status information written by the ST75C52/520 to follow tone detection result, synchronisation in high speed mode, DTMF detection, ...

For that purpose the ST75C52/520 provides following status :

ERROR STATUS (address \$08) :

Provides information about error, can generate an interrupt **IT0**.

STATUS[0], STATUS[1] (addresses \$09, \$0A) :

Contain all the Modem signals, can generate an interrupt **IT4**.

STAQUA (address \$0B) :

Contains the quality of the received signal.

STAOP[0], STAOP[1], STAOP[2] (addresses \$0C, \$0D, \$0E) :

Optional status that contain additional information regarding the ST75C52/520 operating mode. This default information can be changed to monitor any internal variables.

VI.5 - G3 Fax Equipment

All the information to set up the ST75C52/520 in phase A,B,C,D and E (T.30 protocol) are described in chapter III of the ST75C52/520 User's Manual. The user will find the COMMAND, STATUS information required. A lot of flow charts detail the procedure to initialize low speed (V.21 ch2) and high speed (V.27ter, V.29, V.17) transmission and reception.

Figure 5 : Data Rx Buffer Flow Chart

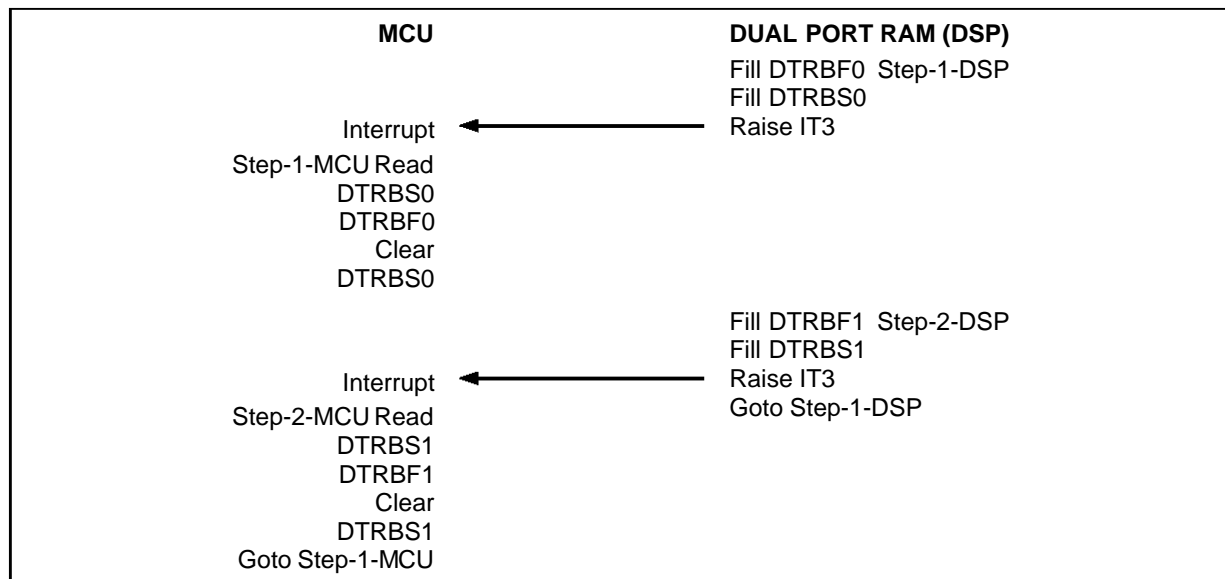

AN814-05.EPS

VII - FLAG DETECTION

This chapter describes the way to use the flag_ detection provided by the ST75C52/520 status report which will be used by a Host micro-controller.

VII.1 - V.21 Chanel 2 Flag 7E Detection

The ST75C52/520 provides in the **STATUS1** (address \$0A in the host interface) the **STA_FLAG** bit. **STATUS1** is an 8 bit register that can be read (only) by the host. Bit position 7 corresponds to the MSB and bit position 0 corresponds of the LSB.

In this register bit 6 (position 6) is called **STA_FLAG** (valid only in FAX modem and tone mode). **STA_FLAG** equal to 1 means that a V.21 ch2 flag is detected.

Three flags are necessary to validate V.21 flag. So minimum timing for V.21 flag detection is :

$$3.3ms \times 8 \times 3 = 79.2ms.$$

At this optimum timing you have to add the response time for the filters and the time for synchronisation of state machine at the beginning of the flag. The overall detection of V.21 ch2 flag is between **92** and **98ms**.

The overall time for loss of V.21 ch2 flag is between **17** and **25ms**.

VII.2 - Flag Detection in V.21 Channel 2 Mode

If the ST75C52/520 is set to receive in V.21 channel 2 mode, the V.21 flag detector is always available.

The following flow chart shows how the host must used the ST75C52/520 to detect V.21 ch2 flag while receiving in low speed mode (See Figure 6).

Figure 6

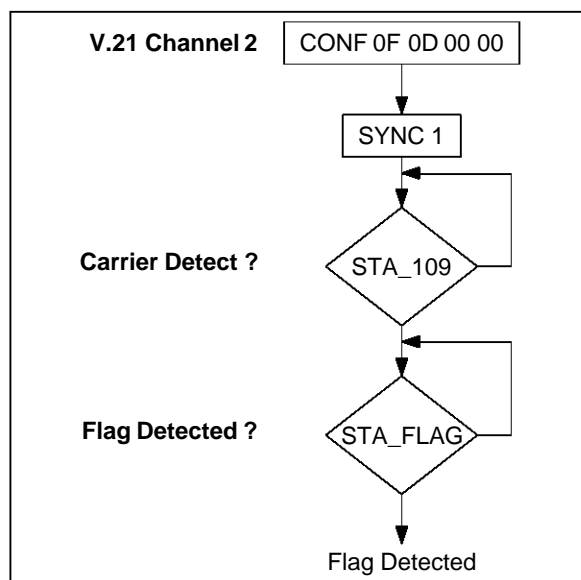

AN814-06.EPS

VII.3 - Flag Detection in High Speed Mode
VII.3.1 - Flag Detection at the Beginning of C Phase or TCF Reception

In such a case the ST75C52/520 is setting up to receive in V.27, V.29 or V.17. When the host starts the synchronisation of the reception sending the **SYNC 1** command to the ST75C52/520, the internal DSP executes two tasks in which the V.21 ch2 flag detection is activated :

- looking for V.21 ch2 signal,
- looking for training in high speed mode.

The V.21 ch2 flag detection is not available when the ST75C52/520 is in data mode (the training is completed, the carrier detect signal and the **STA_109** are true indicating a received high speed modulation).

Figure 7 shows when the flag detection is available.

Figure 7 : ST75C52/520 High Speed Received Sequence

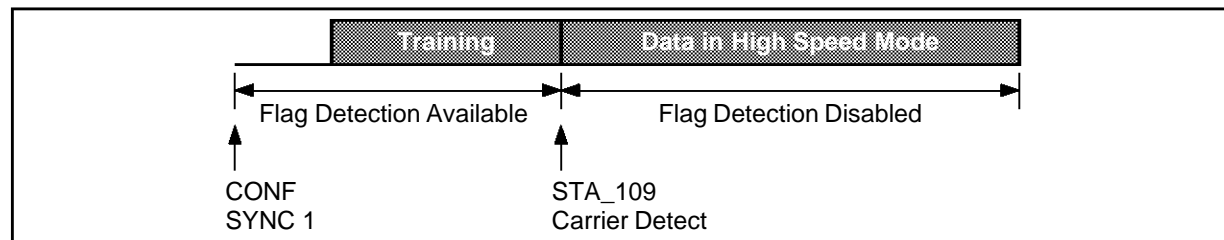

AN814-07.EPS

V.17 FAX EQUIPMENT REPLACING THE R144EFX

Figure 8 shows how the host can use the ST75C52/520 for flag detection when receiving TCF frame or at the beginning of C phase.

VII.3.2 - Flag Detection in C Phase

As said above the flag detection is not available while the ST75C52/520 is receiving data in high speed mode (V.17, V.29, V.27) since the DSP disables it as soon as the carrier detect status (STA_109) is true.

It could be interesting for the host to have the **STA_FLAG** information available in C phase just after a loss of the high speed carrier because the next received signal could be a V.21 ch2 instead a high speed carrier without a training.

Figure 9 summarizes the two cases.

In the first case the transmit unit has cut the high speed transmission (which causes the loss of the carrier) and start to send HDLC frames in V.21 ch2.

In the second case the loss of the carrier may be due to a problem on the PSTN network.

Figure 8

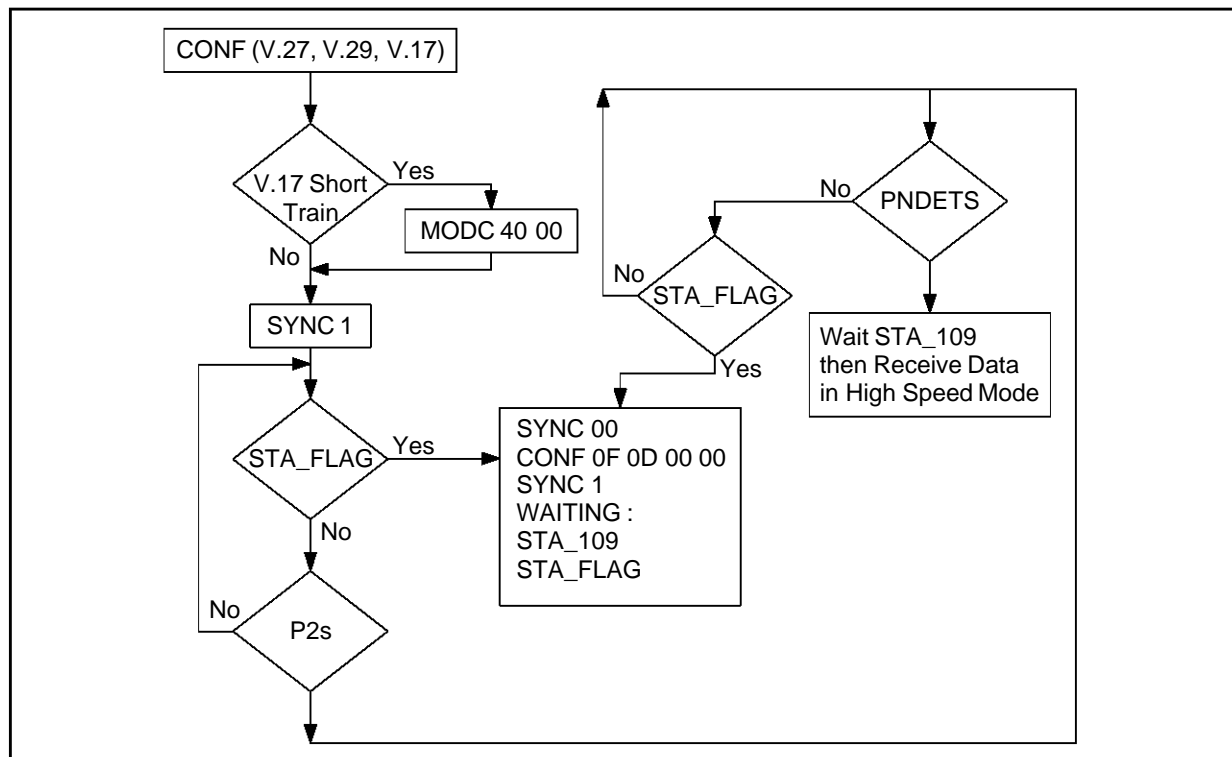

AN814-08.EPS

Figure 9 : ST75C52/520 Received Signal with Loos of Carrier

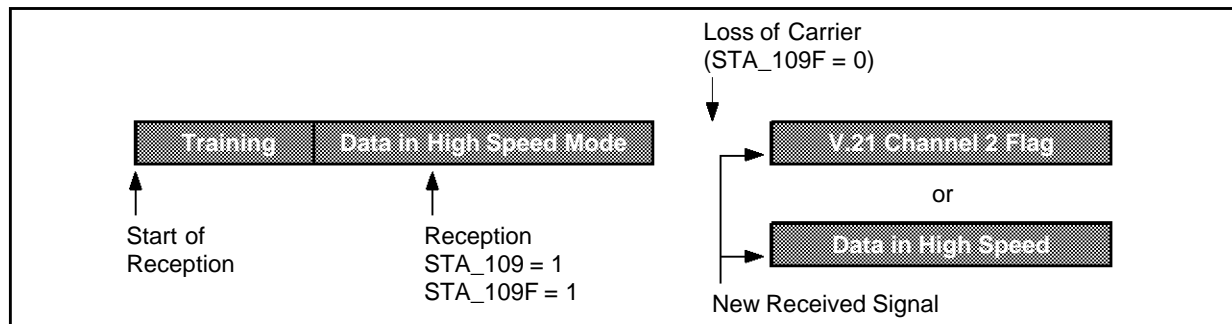

AN814-08.EPS

V.17 FAX EQUIPMENT REPLACING THE R144EFX

Figure 10 gives to the user the way to be able to detect V.21 ch2 flag just after a loss of high speed carrier.

To enable and disable the flag detection the host will perform a Memory Write (MW) command (see Table 1 for addresses and parameters). As the short train is only used in C phase while receiving in V.17 mode the host can avoid to send the Enb short sequence to the ST75C52/520 in V.29 and V.27.

This flow chart (Figure 10) could be used in phase B but take care that the Enb short sequence must only be sent in C phase.

VIII - EQUALIZER AT RECEPTION SIDE

The DSP provides an equalizer function in the reception section. It computes the coefficients of this equalizer firstly during the training and secondly during the first seconds of the data mode (carrier detect signal and **STA_109** are true).

In Fax application the coefficients are firstly computed when receiving the TCF frame (continuous 0 during 1.5s) in phase B of the T.30 protocol. As the DSP rev 1.0 software takes more than 1.5s when in data mode to compute the coefficients of the equalizer the host must reduce these time sending to the DSP two memory write (**MW**) command. The two **MW** must be sent just after **STA_109** equals 1 indicating a high speed modulation signal :

First MW MW E3 16 01 00

Second MW MW E3 16 B0 04

The DSP will take now 1.2s after the beginning of the data mode (**STA_109** = 1) to compute the coefficients of the equalizer.

For DSP rev 1.1 software the problem is solved and the two **MW** need not be sent by the host.

Figure 10

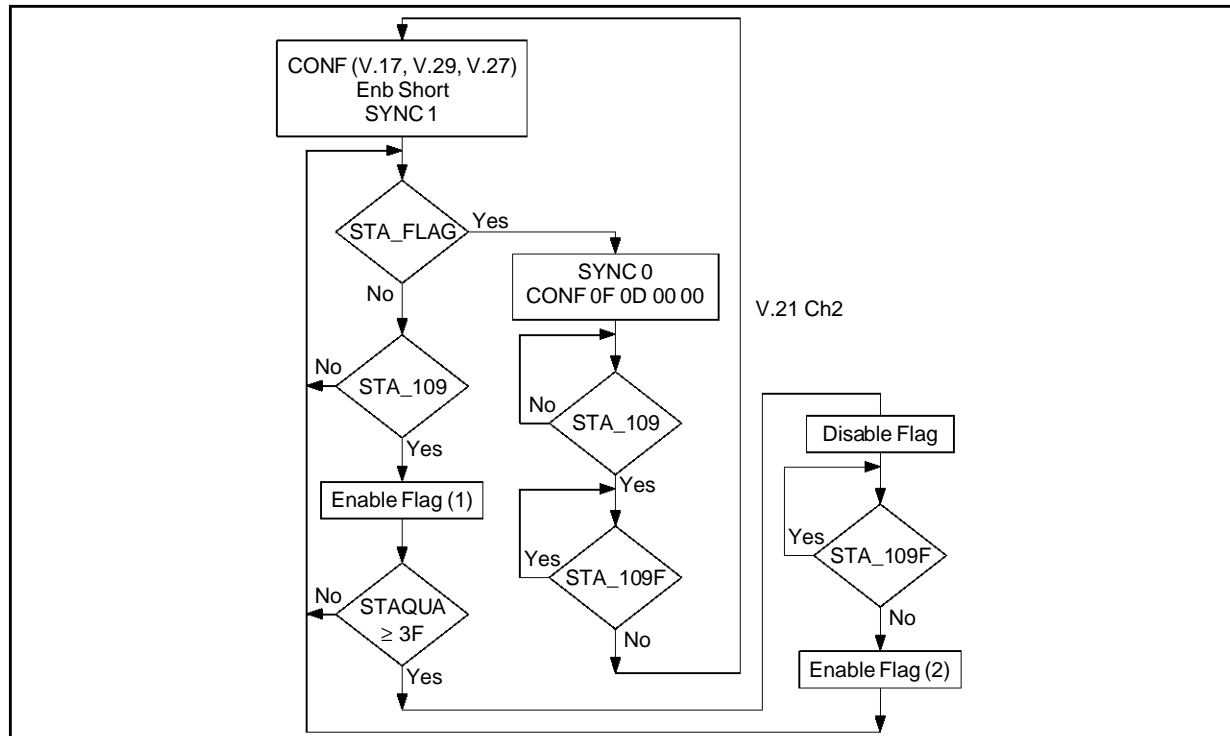

Table 1

	V.17	V.29	V.27
CONF HIGH SPEED	CONF 0F 09 00 04	CONF 0F 08 00 01	CONF 0F 07 40 00
Enbl Flag (1)	MW 15 10 14 00	MW 15 10 12 00	MW 15 10 12 00
Enbl Flag (2)	MW 15 10 14 00	MW 15 10 10 00	MW 15 10 10 00
Disable Flag	MW 15 10 04 00	MW 15 10 00 00	MW 15 10 00 00
Enb Short	MODC 40 00	MODC 00 00	MODC 00 00

V.17 FAX EQUIPMENT REPLACING THE R144EFX

IX - HOW ADJUST THE TRANSMIT LEVEL

As explained in the ST75C52/520 User's Manual in chapter VI.3 the user can adjust the level on the line using the **SETGN** command. Like that the user chooses an attenuation in the transmit section (no attenuation means a 0dB value for the parameter of the **SETGN** command).

There is no limitation for the attenuation values. You can use different attenuation values with a step less than 1dB between each value. The USER'S MANUAL gives as example the value for attenuation between 0dB and -14dB with a step of 1dB.

How to compute the value of the parameter for the **SETGN** command ?

As the attenuation is provided by a gain in the transmit section you must know the value of the next gain which gives the wanted attenuation. 0dB attenuation means a unit gain ($G_t = 1$). For 0dB the value of the **SETGN** parameter is 7FFF (hexa decimal value) or 32768 (decimal value). Suppose

you would like a -10dB attenuation, in such a case your attenuation gain will have a value of $G_t = 0.6065$. The value of the **SETGN** parameter will be equal to 32768×0.6065 (decimale value) or 287A (hexadecimal value).

Now the host has only to send **SETNG 287A** (command and parameter) to the DSP to set up the attenuation gain at the wanted value.

X - HARDWARE GUIDE LINE

The ST75C52/520 can be connected to a host processor using INTEL or MOTOROLA bus.

A synchronisation between the ST75C52/520 and the host is provided with **SDTACK** (for data acknowledge) and **SINTR** (for interrupts) signals which are both open drain.

The analog interface is detailed in chapter VI, VII, VII of the ST75C52/520 User's Manual.

Here, we briefly cover the basic schematics and hybrid interface tuning (See Figure 11).

Figure 11

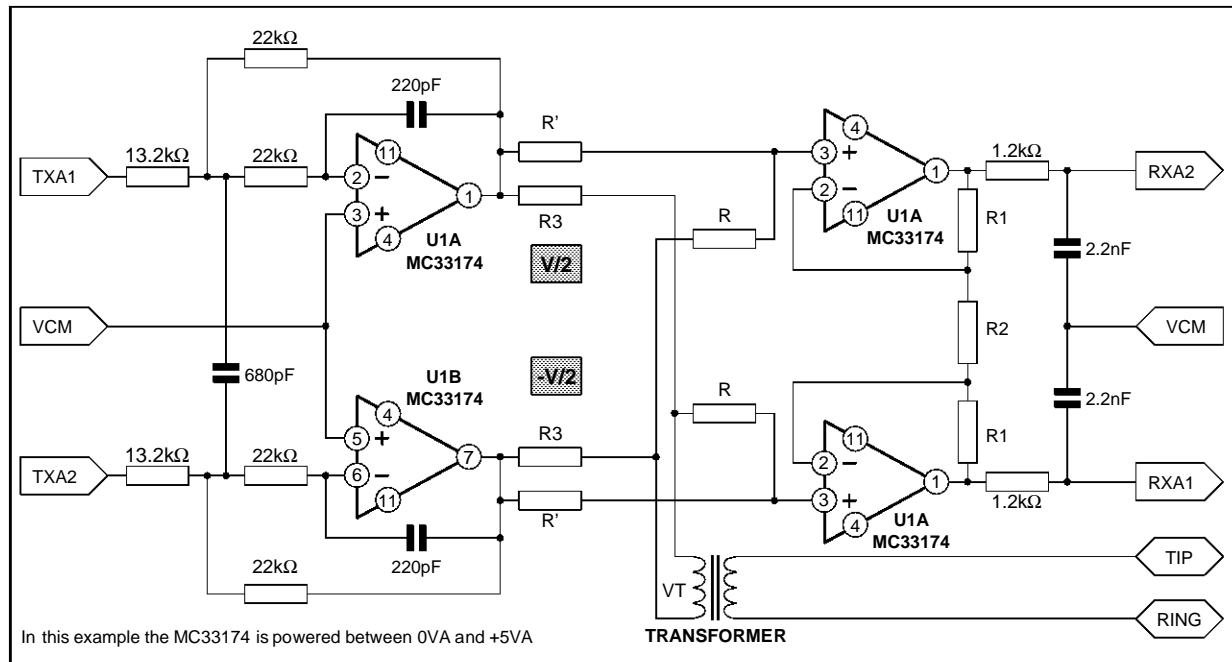

V.17 FAX EQUIPMENT REPLACING THE R144EFX

Components :

All resistors are 1% tolerance

Operational Amplifier SGS-THOMSON : MC33174

Tuning :

Return Loss :

$$R3 = \frac{R0}{2}$$

Where R0 is the value for the best return loss versus the reference impedance Z0. And Z0 = 600Ω or Complex Impedance

Duplexor :

$$V_T = \frac{Z0 \cdot V}{(Z0 + R0)}$$

$$\text{Coef} = \frac{V_T}{V} = \frac{Z0}{Z0 + R0}$$

To have the best rejection : $R' = \frac{R}{\text{Coef}}$

Example 1:

Z0 = 600Ω, R0 = 600Ω

Coef = 0.5

R = 20kΩ and R' = 40kΩ

Example 2 :

Z0 = 600Ω, R0 = 440Ω

Coef = 0.577

R = 23.08kΩ and R' = 40kΩ

Transmit Gain :

Tx_Gain = 22kΩ/13.2kΩ

Today tuned to have -9dBm on the line.

To transmit at 0dBm you must :

- Replace the two 13.2kΩ 1% by two 4.64kΩ 1%.
- Replace the two 220pF by 47pF.
- Power supply of the Amplifier : +V and -V.

Receive Gain :

$$\text{Rx_Gain} = 1 + \frac{R1}{\left(\frac{R2}{2}\right)}$$

Typical values R1 = 15kΩ, R2 = 82kΩ

Information furnished is believed to be accurate and reliable. However, SGS-THOMSON Microelectronics assumes no responsibility for the consequences of use of such information nor for any infringement of patents or other rights of third parties which may result from its use. No licence is granted by implication or otherwise under any patent or patent rights of SGS-THOMSON Microelectronics. Specifications mentioned in this publication are subject to change without notice. This publication supersedes and replaces all information previously supplied. SGS-THOMSON Microelectronics products are not authorized for use as critical components in life support devices or systems without express written approval of SGS-THOMSON Microelectronics.

© 1995 SGS-THOMSON Microelectronics - All Rights Reserved

Purchase of I²C Components of SGS-THOMSON Microelectronics, conveys a license under the Philips I²C Patent. Rights to use these components in a I²C system, is granted provided that the system conforms to the I²C Standard Specifications as defined by Philips.

SGS-THOMSON Microelectronics GROUP OF COMPANIES

Australia - Brazil - China - France - Germany - Hong Kong - Italy - Japan - Korea - Malaysia - Malta - Morocco
The Netherlands - Singapore - Spain - Sweden - Switzerland - Taiwan - Thailand - United Kingdom - U.S.A.



LittleDiode supplies new, hard to find or obsolete electronic components and semiconductors all over the world.

With over two million different components listed you are sure to find the part you need.

Feel free to visit us today at our online store:

LittleDiode.com

Looking forward to providing you with the best possible service.