

# AN8124K

## 8-Bit A/D and D/A Compound Converter

### ■ Overview

The AN8124K is a 8-bit A/D and D/A compound converter for image processing.

### ■ Features

- Reference Voltage Source Built-in
- Maximum conversion rate : 20 MSPS (min.)
- Sample holding circuit not required
- Low consumption power : 250 mW (typ.)
- Digital input/output level : TTL compatible

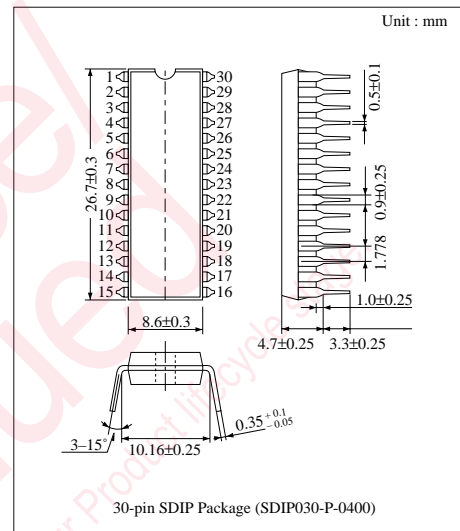

### ■ Block Diagram

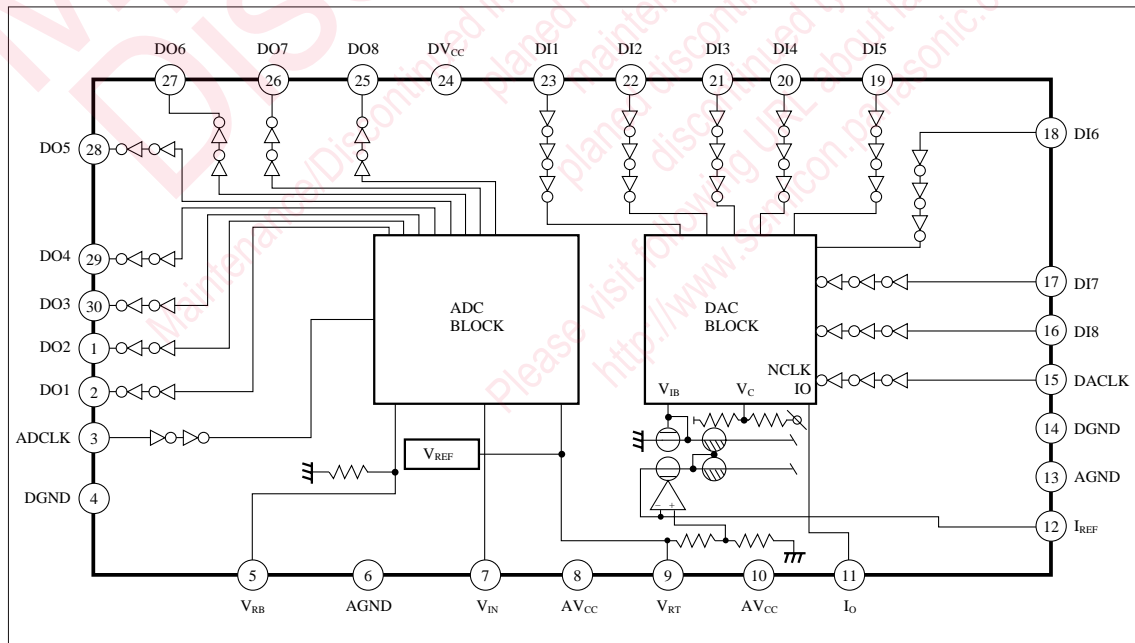

### ■ Absolute Maximum Rating (Ta=25°C)

Parameter	Symbol	Rating	Unit
Supply voltage	V <sub>CC</sub>	7	V
Supply current	I <sub>CC</sub>	100	mA
Analogue input voltage	V <sub>IN</sub>	-0.5 to V <sub>CC</sub> + 0.3	V
Digital input voltage	V <sub>CLK</sub>	-0.5 to V <sub>CC</sub> + 0.3	V
Digital output current	I <sub>OH</sub>	-15	mA
Digital output current	I <sub>OL</sub>	15	mA
Reference resistive voltage	V <sub>RT</sub>	-0.5 to V <sub>CC</sub> + 0.3	V
	V <sub>RB</sub>	-0.5 to V <sub>CC</sub> + 0.3	V
Digital input voltage	V <sub>DI</sub>	-0.5 to V <sub>CC</sub> + 0.3	V
Analogue output current	I <sub>O</sub>	30	mA
Reference current	I <sub>REF</sub>	10	mA
Power dissipation	P <sub>D</sub>	700	mW
Operating ambient temperature	T <sub>opr</sub>	-20 to +70	°C
Storage temperature	T <sub>sg</sub>	-55 to +150	°C

### ■ Recommended Operating Conditions (Ta=25°C)

Parameter	Symbol	Condition	min	typ	max	Unit
Supply voltage	V <sub>CC</sub>		4.75	5	5.25	V
Analogue input voltage	V <sub>IN</sub>		V <sub>RB</sub>	—	V <sub>RT</sub>	V
Output load resistance	R <sub>O</sub>		—	220	—	Ω
Digital input voltage	V <sub>IH</sub>		2.4	—	—	V
	V <sub>IL</sub>		—	—	0.8	V
Clock input pulse width	t <sub>WH</sub>	Refer to the timing chart.	25	—	—	ns
	t <sub>WL</sub>	Refer to the timing chart.	25	—	—	ns
Setting-up time	t <sub>s</sub>	Refer to the timing chart.	20	—	—	ns
Holding time	t <sub>H</sub>	Refer to the timing chart.	20	—	—	ns

### ■ Electrical Characteristics (V<sub>CC</sub>=5V, Ta=25°C)

Parameter	Symbol	Condition	min	typ	max	Unit
Supply current	I <sub>CC</sub>	f <sub>CLK</sub> =15MHz, R <sub>REF</sub> =1.8kΩ	—	50	80	mA
Reference voltage	V <sub>RT</sub>		3.1	3.5	3.9	V
	V <sub>RB</sub>	V <sub>IN</sub> = 2.5V	1.1	1.5	1.9	V
Input bias current	I <sub>IN</sub>	V <sub>IN</sub> = 2.4V	—	40	120	μA
Clock input current	I <sub>IH</sub>	V <sub>IL</sub> = 0.4V	—	—	30	μA
	I <sub>IL</sub>	I <sub>OH</sub> = -2mA	-30	—	—	μA
Digital output voltage	V <sub>OH</sub>	I <sub>OL</sub> = 2mA	V <sub>CC</sub> - 0.8	—	—	V
	V <sub>OL</sub>		—	—	0.4	V

#### A/D, D/A

Differential gain	DG		—	1	—	%
Differential phase	DP	f <sub>IN</sub> = 4MHz, f <sub>S</sub> = 20MHz	—	0.5	—	deg
Quantization noise	S/N		33	40	—	dB

■ Electrical Characteristic (Cont.) ( $V_{CC}=5V$ ,  $T_a=25^\circ C$ )

Parameter	Symbol	Condition	min	typ	max	Unit
<b>A/D</b>						
Resolution	RES		—	8	—	bit
Maximum conversion rate	$F_{CMAX}$		20	—	—	MSPS
Linearity error	$E_L$	$V_{RT} = 3.5V$ , $V_{RB} = 1.5V$	—	$\pm 0.5$	$\pm 1$	LSB
Differential linearity error	$E_D$	$V_{RT} = 3.5V$ , $V_{RB} = 1.5V$	—	—	$\pm 0.5$	LSB
Equivalent input impedance	$R_{IN}$	$V_{IN} = 2.5V$	—	500	—	k $\Omega$
Input capacitance	$C_{IN}$	$V_{IN} = 2.5V$	—	40	—	pF
Digital output delay	$\tau_{d1}$		—	25	—	ns
<b>D/A</b>						
Resolution	RES		—	8	—	bit
Maximum conversion rate	$F_{CMAX}$	$R_{OUT} = 220\Omega$ , $R_{REF} = 1.8k\Omega$	20	—	—	MSPS
Linearity error	$E_L$	$R_{OUT} = 220\Omega$ , $R_{REF} = 1.8k\Omega$	—	—	$\pm 0.5$	LSB
Differential linearity error	$E_D$	$R_{OUT} = 220\Omega$ , $R_{REF} = 1.8k\Omega$	—	—	$\pm 0.5$	LSB
Full-Scale current	$I_{FS}$	$R_{OUT} = 220\Omega$ , $R_{REF} = 1.8k\Omega$	3.64	4.55	5.45	mA
Settling time	$t_{ST}$	$R_{OUT} = 220\Omega$ , $R_{REF} = 1.8k\Omega$	—	—	50	ns
Analogue output delay	$\tau_{d2}$		—	25	—	ns

■ A/D Sampling Timing Chart

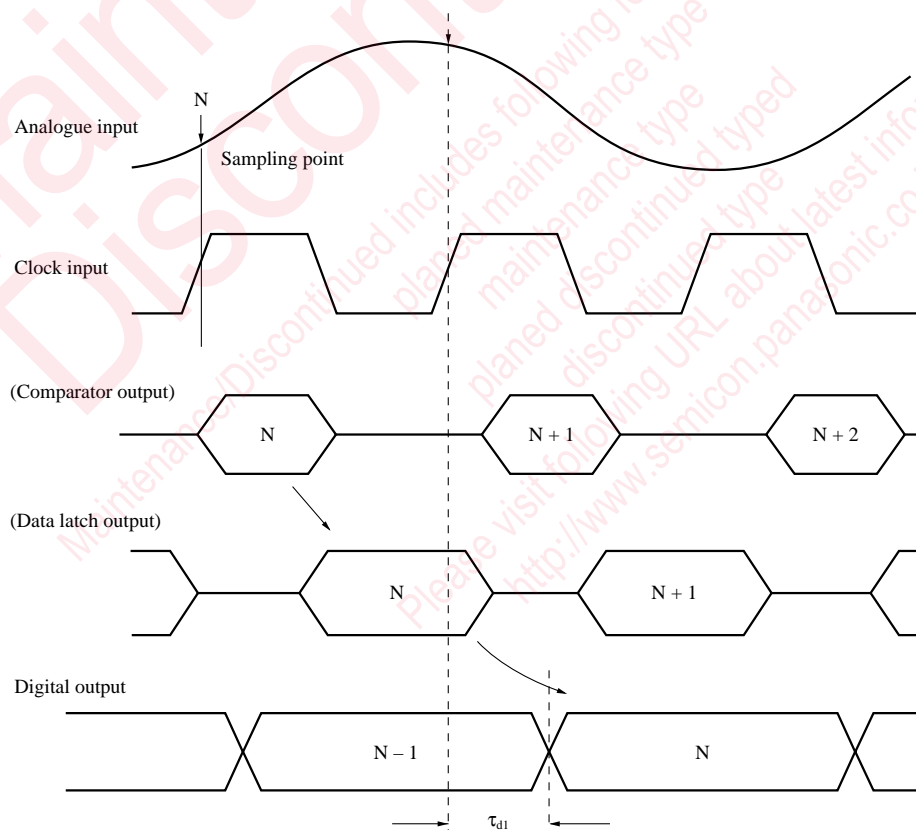

### ■ D/A Timing Chart

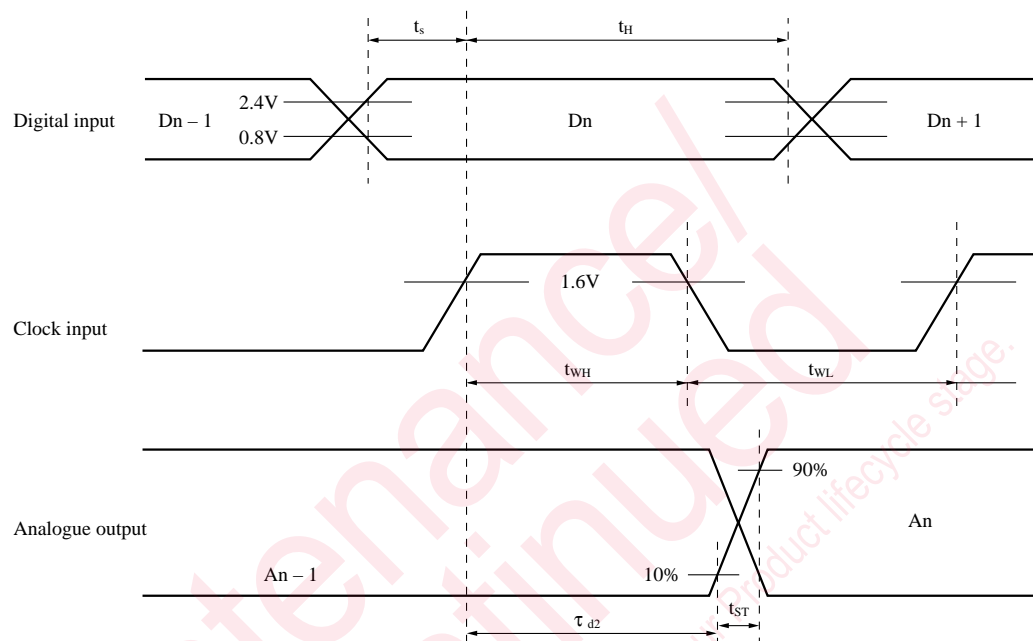

### ■ Pin Descriptions

Pin No.	Symbol	Pin name	Pin No.	Symbol	Pin name
1	DO2	Digital output 2-bit	16	DI8	Digital input 8-bit (LSB)
2	DO1	Digital output 1-bit (MSB)	17	DI7	Digital input 7-bit
3	ADCLK	A/D convertor clock input	18	DI6	Digital input 6-bit
4	DGND	Digital ground	19	DI5	Digital input 5-bit
5	$V_{RB}$	Reference voltage low level	20	DI4	Digital input 4-bit
6	AGND	Analogue ground	21	DI3	Digital input 3-bit
7	$V_{IN}$	Analogue input pin	22	DI2	Digital input 2-bit
8	$AV_{CC}$	Analogue power supply pin	23	DI1	Digital input 1-bit (MSB)
9	$V_{RT}$	Reference voltage high level	24	DV <sub>CC</sub>	Digital power supply pin
10	$AV_{CC}$	Analogue power supply pin	25	DO8	Digital output 8-bit (LSB)
11	$I_{OUT}$	Analogue output	26	DO7	Digital output 7-bit
12	$I_{REF}$	Reference current setting	27	DO6	Digital output 6-bit
13	AGND	Analogue ground	28	DO5	Digital output 5-bit
14	DGND	Digital ground	29	DO4	Digital output 4-bit
15	DACLK	D/A convertor clock input	30	DO3	Digital output 3-bit

■ Application Circuit

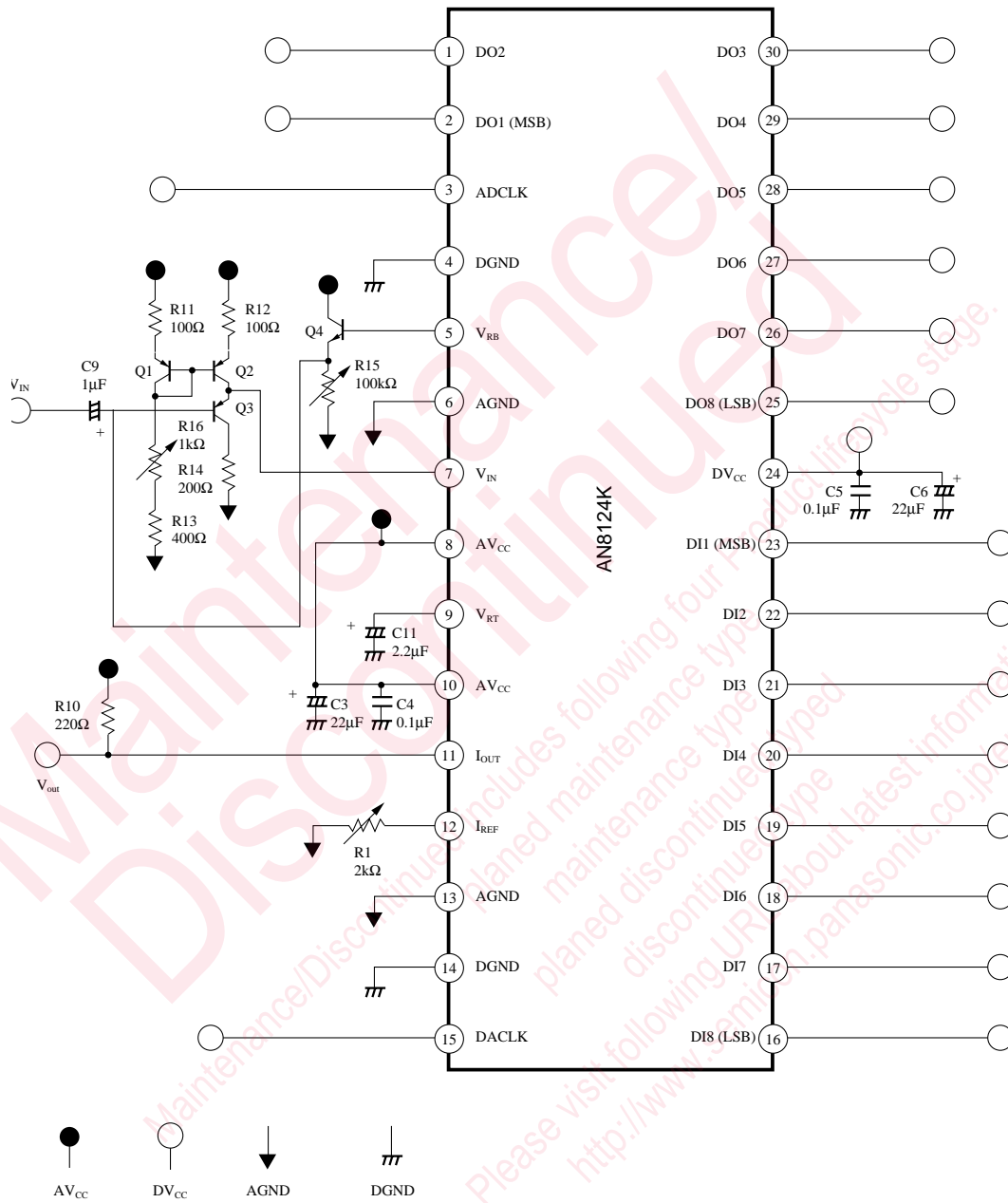

## Request for your special attention and precautions in using the technical information and semiconductors described in this book

- (1) If any of the products or technical information described in this book is to be exported or provided to non-residents, the laws and regulations of the exporting country, especially, those with regard to security export control, must be observed.
- (2) The technical information described in this book is intended only to show the main characteristics and application circuit examples of the products, and no license is granted under any intellectual property right or other right owned by our company or any other company. Therefore, no responsibility is assumed by our company as to the infringement upon any such right owned by any other company which may arise as a result of the use of technical information described in this book.
- (3) The products described in this book are intended to be used for standard applications or general electronic equipment (such as office equipment, communications equipment, measuring instruments and household appliances).  
Consult our sales staff in advance for information on the following applications:
  - Special applications (such as for airplanes, aerospace, automobiles, traffic control equipment, combustion equipment, life support systems and safety devices) in which exceptional quality and reliability are required, or if the failure or malfunction of the products may directly jeopardize life or harm the human body.
  - Any applications other than the standard applications intended.
- (4) The products and product specifications described in this book are subject to change without notice for modification and/or improvement. At the final stage of your design, purchasing, or use of the products, therefore, ask for the most up-to-date Product Standards in advance to make sure that the latest specifications satisfy your requirements.
- (5) When designing your equipment, comply with the range of absolute maximum rating and the guaranteed operating conditions (operating power supply voltage and operating environment etc.). Especially, please be careful not to exceed the range of absolute maximum rating on the transient state, such as power-on, power-off and mode-switching. Otherwise, we will not be liable for any defect which may arise later in your equipment.
  - Even when the products are used within the guaranteed values, take into the consideration of incidence of break down and failure mode, possible to occur to semiconductor products. Measures on the systems such as redundant design, arresting the spread of fire or preventing glitch are recommended in order to prevent physical injury, fire, social damages, for example, by using the products.
- (6) Comply with the instructions for use in order to prevent breakdown and characteristics change due to external factors (ESD, EOS, thermal stress and mechanical stress) at the time of handling, mounting or at customer's process. When using products for which damp-proof packing is required, satisfy the conditions, such as shelf life and the elapsed time since first opening the packages.
- (7) This book may be not reprinted or reproduced whether wholly or partially, without the prior written permission of Matsushita Electric Industrial Co., Ltd.



LittleDiode supplies new, hard to find or obsolete electronic components and semiconductors all over the world.

With over two million different components listed you are sure to find the part you need.

Feel free to visit us today at our online store:

[LittleDiode.com](http://LittleDiode.com)

Looking forward to providing you with the best possible service.