

AN8102FBP

Super High Speed Low Power Consumption 8-Bit A/D Converter

Overview

The AN8102FBP is a 8-bit A/D converter for measurement which uses the high frequency bipolar process to suppress the power consumption.

It can operate with single power supply of -5.2V and maximum conversion rate of 125MSPS, realizing the low error rate.

Features

- 8-bit resolution
- Super high speed : maximum conversion rate of 125 MSPS (min.)
- Low error rate : 10^{-12} tps or lower
- Low input capacitance : 15pF
- Input/Output form : ECL level

Application Field

- Measuring equipment such as digital oscilloscope
- Image processing

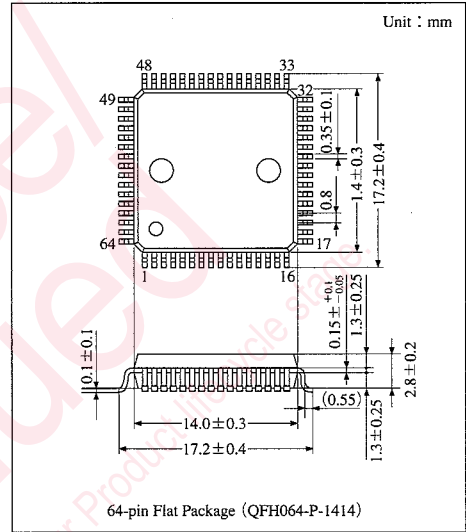

Block Diagram

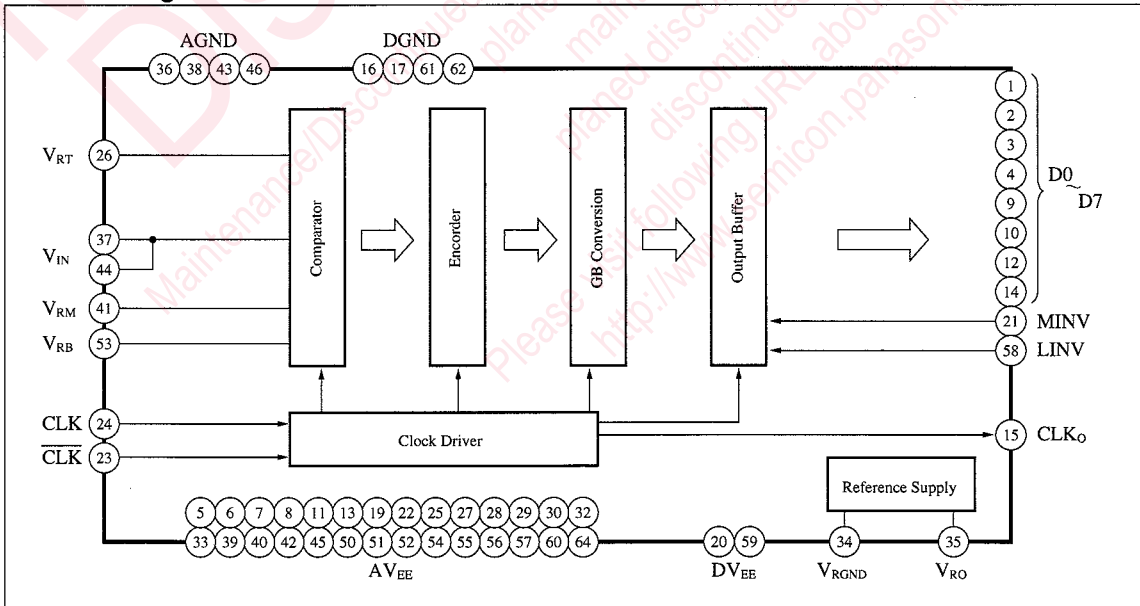

Absolute Maximum Rating (Ta=25°C)

Parameter	Symbol	Rating	Unit
Supply voltage	V _{EE}	-6.0 to +0.3	V
Analogue input voltage	V _{IN}	V _{EE} to +0.3	V
Digital input voltage	V _{CLK} /√V _{CLK}	V _{EE} to +0.3	V
Digital output current	I _{CLKO} /I _{D0} ~I _{D7}	-20	mA
Reference power supply output current	I _{RO}	25	mA
Reference resistive current	I _{RT} /I _{RB}	+20/-20	mA
Reference voltage	V _{RT} /V _{RB} /V _{RM}	V _{EE} to +0.3	V
Power dissipation	P _D	964*	mW
Operating ambient temperature	T _{opr}	-20 to +70	°C
Storage temperature	T _{stg}	-55 to +150	°C

* Ta=70°C

Recommended Operating Conditions (Ta=25°C)

Parameter	Symbol	min	typ	max	Unit
Supply voltage	V _{EE}	-5.4	-5.2	-5.0	V
Reference voltage	V _{RT}	—	0.0	—	V
	V _{RB}	—	-2.0	—	V
Analogue input voltage	V _{IN}	V _{RB}	—	V _{RT}	V
Digital input voltage	V _{IH}	-1.1	-0.9	—	V
	V _{IL}	—	-1.7	-1.5	V
Clock input pulse width *	t _H /t _L	—	5	—	ns

* f_{CLK} = 100MHz

Electrical Characteristics (V_{EE} = -5.2V, Ta=25°C)

Parameter	Symbol	Condition	min	typ	max	Unit
Supply current	I _{EE}		-195	-135	-85	mA
Reference power supply output voltage	V _{RO}	I _{RO} = 10mA, V _{RGND} = 0V	-2.2	-2.0	-1.8	V
Reference supply current	I _{RGND}	Reference power supply output under no Load	0.5	2.0	5	mA
Reference resistive current	I _{RT}	V _{RT} = 0V	4	10	20	mA
	I _{RB}	V _{RB} = -2.0V	-20	-10	-4	mA
Input bias current	I _{IN}	V _{IN} = -1.0V	—	120	250	μA
Clock input current	I _{IH}	V _{CLK} = -1.105V	—	1.0	5.0	μA
Digital output voltage	V _{OH}	R _L = 100Ω TO V _T = -2.0V	-1.1	-0.9	-0.6	V
	V _{OL}		-2.0	-1.8	-1.6	V
Linearity error	E _L	V _{RT} - V _{RB} = 2.0V	—	±0.25	±0.5	LSB
Differential linearity error	E _D	V _{RT} - V _{RB} = 2.0V	—	±0.25	±0.5	LSB
Maximum conversion rate	F _{CMAX}		125	—	—	MHz
Input dynamic range			—	2	—	V _{p-p}
Equivalent input impedance *1	R _{IN}	V _{IN} = -1V	—	350	—	kΩ
Input capacitance *1	C _{IN}	V _{IN} = -1V	—	15	20	pF
Error rate *1		f _{CLK} = 125MHz, f _{IN} = 40.5MHz 8LSB or higher	—	—	10 ⁻¹²	tps
Quantization noise *2	SINAD	f _{CLK} = 125MHz, f _{IN} = 10MHz	38	43	—	dB
		f _{CLK} = 125MHz, f _{IN} = 50MHz	30	35	—	dB
Input band *1	BW _F	V _{IN} = 2V _{p-p} , -3dB	—	125	—	MHz
Clock duty *1	DTY	f _{CLK} = 125MHz	30	50	70	%
Clock output delay *1	τ _c		5	7	9	ns
Digital output delay *1	τ _d		—	1.3	—	ns

*1 Design reference value but not guaranteed one *2 Total harmonics distortion included

A/D and D/A Converters

■ Timing Chart

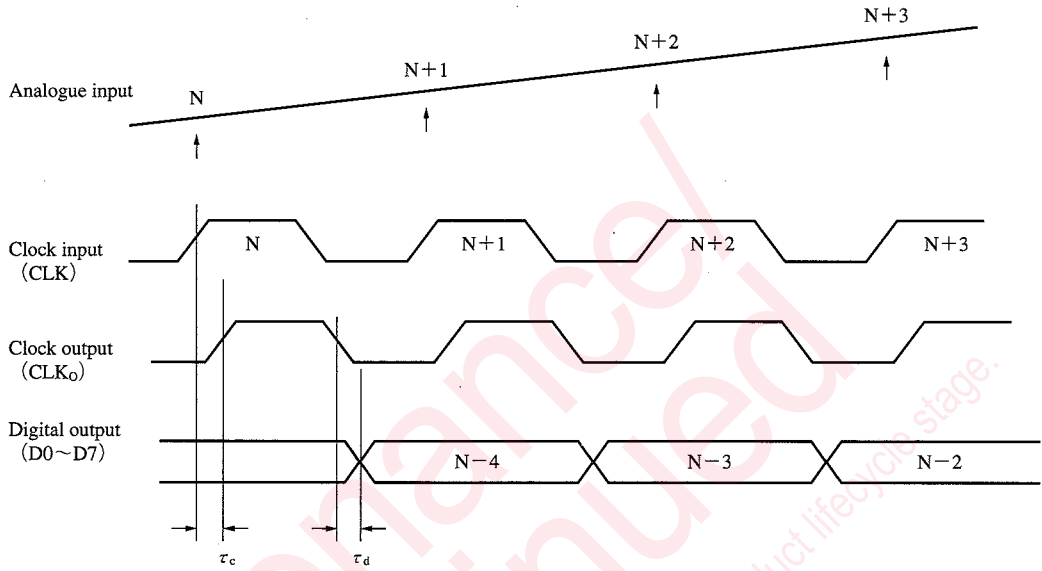

■ Output Code

Step	Input signal			Digital output					
	2.000VFS	7.8125mV	STEP	MINV=L, LINV=L		MINV=H, LINV=L		MINV=L, LINV=H	
				M	L	M	L	M	L
000		-2.0000000		00000000	10000000	01111111			
001		-1.9921875		00000001	10000001	01111110			
.				
.				
127		-1.0078125		01111111	11111111	00000000			
128		-1.0000000		10000000	00000000	11111111			
129		-0.9921875		10000001	00000001	11111110			
.				
.				
254		-0.0078125		11111110	01111110	10000001			
255		-0.0000000		11111111	01111111	10000000			

Pin Descriptions

Pin No.	Symbol	Pin name	Standard waveform	Voltage level	Description
37 34	V_{IN}	Analogue input		-2 to 0V	It is an input pin of analogue signal for A/D conversion circuit.
36, 38 43, 46	AGND	Analogue ground		0V	Connect AGND and DGND with the possible lowest impedance at one point as near as possible to the chip.
5, 6, 7 8, 11, 13 19, 22, 25 27, 28, 29 30, 32, 33 39, 40, 42 45, 50, 51 52, 54, 55 56, 57, 60 64	AV_{EE}	Analogue negative power supply pin		-5.2V	It is a power supply pin for analogue circuit block. Connect tantalum capacitor of several μF and ceramic capacitor of 0.1 μF as near as possible to this pin between this pin and AGND.
20, 59	DV_{EE}	Digital negative power supply pin		-5.2V	It is a power supply pin for digital circuit block. Connect tantalum capacitor of several μF and ceramic cap capacitor of 0.1 μF as near as possible to this pin between this pin and DGND.
26 41 53	V_{RT} V_{RM} V_{RB}	Reference voltage high level Reference voltage middle point level Reference voltage low level		0V -1.0V -2.0V	It is used to set the reference voltage for comparator. Normally, V_{RT} is given 0V and V_{RB} is given -2 V. Connect tantalum capacitor of several μF and ceramic capacitor of 0.1 μF in parallel between each pin and analogue ground. V_{RM} is provided for linearity compensation which gives middle point potential between V_{RT} and V_{RB} . However, it is normally opened.
16, 17 61, 62	DGND	Digital ground		0V	Connect AGND and DGND with the possible lowest impedance at one point as near as possible to the chip.
23 24	\overline{CLK} CLK	Clock input	Refer to the timing chart	ECL	It is a clock for sampling. For their timing, refer to the timing chart.
15	CLK _O	Clock output	Refer to the timing chart	ECL	It is a clock output pin of ECL level.
1 2 3 4 9 10 12 14	D0 D1 D2 D3 D4 D5 D6 D7	Digital output (LSB) Digital output Digital output Digital output Digital output Digital output Digital output Digital output (MSB)	Refer to the timing chart	ECL	It is an output pin of ECL Level.
21 58	MINV LINV	Digital output setting pin Digital output setting pin		ECL	Setting the MINV pin to "H" level inverts the data output, D7. Setting the LINV pin to "H" level inverts the data outputs (D0 ~ D6). The output is inverts synchronously with clock.
34 35	V_{RGND} V_{RO}	Ground pin for reference power supply reference power supply output		0V -2.0V	It is a GND pin for reference power supply. It is an output pin for power supply for A/D reference voltage low level.



Request for your special attention and precautions in using the technical information and semiconductors described in this book

- (1) If any of the products or technical information described in this book is to be exported or provided to non-residents, the laws and regulations of the exporting country, especially, those with regard to security export control, must be observed.
- (2) The technical information described in this book is intended only to show the main characteristics and application circuit examples of the products. No license is granted in and to any intellectual property right or other right owned by Panasonic Corporation or any other company. Therefore, no responsibility is assumed by our company as to the infringement upon any such right owned by any other company which may arise as a result of the use of technical information described in this book.
- (3) The products described in this book are intended to be used for standard applications or general electronic equipment (such as office equipment, communications equipment, measuring instruments and household appliances).
Consult our sales staff in advance for information on the following applications:
 - Special applications (such as for airplanes, aerospace, automobiles, traffic control equipment, combustion equipment, life support systems and safety devices) in which exceptional quality and reliability are required, or if the failure or malfunction of the products may directly jeopardize life or harm the human body.
 - Any applications other than the standard applications intended.
- (4) The products and product specifications described in this book are subject to change without notice for modification and/or improvement. At the final stage of your design, purchasing, or use of the products, therefore, ask for the most up-to-date Product Standards in advance to make sure that the latest specifications satisfy your requirements.
- (5) When designing your equipment, comply with the range of absolute maximum rating and the guaranteed operating conditions (operating power supply voltage and operating environment etc.). Especially, please be careful not to exceed the range of absolute maximum rating on the transient state, such as power-on, power-off and mode-switching. Otherwise, we will not be liable for any defect which may arise later in your equipment.
 - Even when the products are used within the guaranteed values, take into the consideration of incidence of break down and failure mode, possible to occur to semiconductor products. Measures on the systems such as redundant design, arresting the spread of fire or preventing glitch are recommended in order to prevent physical injury, fire, social damages, for example, by using the products.
- (6) Comply with the instructions for use in order to prevent breakdown and characteristics change due to external factors (ESD, EOS, thermal stress and mechanical stress) at the time of handling, mounting or at customer's process. When using products for which damp-proof packing is required, satisfy the conditions, such as shelf life and the elapsed time since first opening the packages.
- (7) This book may be not reprinted or reproduced whether wholly or partially, without the prior written permission of our company.



LittleDiode supplies new, hard to find or obsolete electronic components and semiconductors all over the world.

With over two million different components listed you are sure to find the part you need.

Feel free to visit us today at our online store:

LittleDiode.com

Looking forward to providing you with the best possible service.