

# AN80LXXRMS Series

## Low-drop type positive output voltage regulator IC

### ■ Overview

The AN80LXXRMS series is 0.15 A output low-drop output type positive voltage regulator IC with resetting function. 20 classifications of output voltages, 1.8 V, 1.9 V, 2.0 V, 2.1 V, 2.2 V, 2.5 V, 2.8 V, 2.9 V, 3.0 V, 3.1 V, 3.2 V, 3.3 V, 3.4 V, 3.5 V, 3.6 V, 4.8 V, 4.9 V, 5.0 V, 5.1 V and 5.2 V are available. In addition, it is adopting the surface mounting type package (Mini 5-pin plastic package), so that it is most suited for miniaturization and weight reduction of set equipment.

### ■ Features

- Minimum input and output voltage difference : 0.4 V max.
- High precision output voltage : (allowance :  $\pm 3\%$ )
- Built-in reset function terminal (High : Active)
- Built-in overcurrent limiting circuit
- Built-in circuit for limiting rush current at input voltage rising time
- Output voltage : 1.8 V to 5.2 V

### ■ Applications

- Cellular phone, PHS, analog cordless phone, other small sized portable equipment

### ■ Block diagram

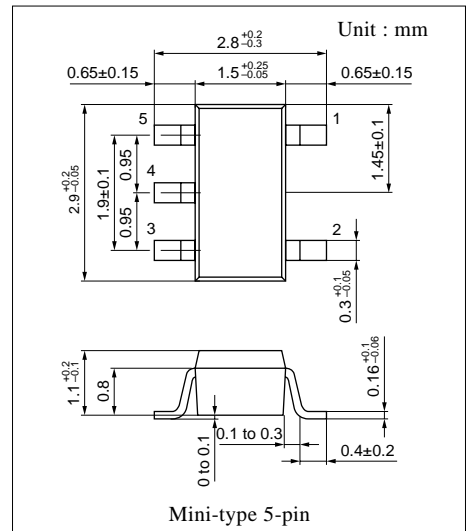
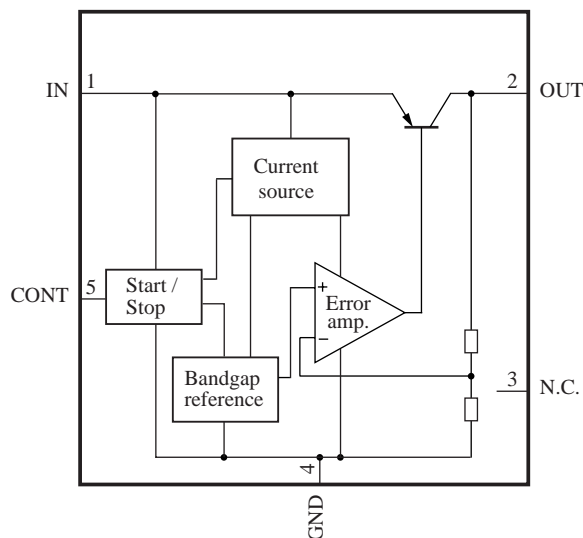

Type name indication symbol : XX

**■ Output Voltage Characteristics at  $I_{OUT} = 50 \text{ mA}$ ,  $T_a = 25^\circ\text{C}$** 

Type No.	Output V	Conditions	min.	typ.	max.	Unit	Marking
AN80L18RMS	1.8	$V_{IN} = 2.8 \text{ V}$	1.746	1.8	1.854	V	BA
AN80L19RMS	1.9	2.9	1.843	1.9	1.957		BB
AN80L20RMS	2.0	3.0	1.940	2.0	2.060		BC
AN80L21RMS	2.1	3.1	2.037	2.1	2.163		BD
AN80L22RMS	2.2	3.2	2.134	2.2	2.266		BE
AN80L25RMS	2.5	3.5	2.452	2.5	2.575		BW
AN80L28RMS	2.8	3.8	2.716	2.8	2.884		BF
AN80L29RMS	2.9	3.9	2.813	2.9	2.987		BG
AN80L30RMS	3.0	4.0	2.910	3.0	3.090		BH
AN80L31RMS	3.1	4.1	3.007	3.1	3.193		BJ
AN80L32RMS	3.2	4.2	3.104	3.2	3.296		BK
AN80L33RMS	3.3	4.3	3.201	3.3	3.399		BL
AN80L34RMS	3.4	4.4	3.298	3.4	3.502		BM
AN80L35RMS	3.5	4.5	3.395	3.5	3.605		BN
AN80L36RMS	3.6	4.6	3.492	3.6	3.708		BP
AN80L48RMS	4.8	5.8	4.656	4.8	4.944		BQ
AN80L49RMS	4.9	5.9	4.753	4.9	5.047		BR
AN80L50RMS	5.0	6.0	4.850	5.0	5.150		BS
AN80L51RMS	5.1	6.1	4.947	5.1	5.253		BT
AN80L52RMS	5.2	6.2	5.044	5.2	5.356		BU

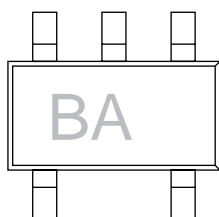

(Marking example : AN80L18RMS)

## Common to the AN80LXXRMS Series

## ■ Pin Descriptions

Pin No.	Description
1	Input voltage pin
2	Output voltage pin
3	N.C. pin
4	Grounding pin
5	Control pin ("High" → operation "Low" → stop)

## ■ Absolute Maximum Ratings

Parameter	Symbol	Rating	Unit
Supply voltage <sup>*1</sup>	$V_{CC}$	14.6	V
Supply current	$I_{CC}$	300	mA
Power dissipation <sup>*3</sup>	$P_D$	78	mW
Operating ambient temperature <sup>*2</sup>	$T_{opr}$	-30 to +85	°C
Storage temperature <sup>*2</sup>	$T_{stg}$	-55 to +150	°C

Note) \*1 : There may be a case of the device destruction when the output ( $V_{OUT}$ ) and the grounding (GND), or the output ( $V_{OUT}$ ) and input ( $V_{IN}$ ) are short-circuited.

\*2 : All items are at  $T_a = 25^\circ\text{C}$ , except for the parameter of operating ambient temperature and storage temperature.

\*3 :  $T_{opr}$  = Power dissipation for IC alone without heat sink at  $+85^\circ\text{C}$ .

## AN80L18RMS (1.8 V)

## ■ Recommended Operating Range

Parameter	Symbol	Range	Unit
Supply voltage	$V_{CC}$	2.2 to 14.5	V

■ Electrical Characteristics at  $T_a = 25^\circ\text{C}$ 

Note) Unless otherwise specially provided, shorten each test time (within 10 ms) so that the test is conducted under the condition that the drift due to the temperature increase in the chip junction part can be neglected.  $C_{IN} = 0.1 \mu\text{F}$ ,  $C_{OUT} = 10 \mu\text{F}$

Parameter	Symbol	Conditions	Min	Typ	Max	Unit
Output voltage	$V_{OUT}$	$V_{IN} = 2.8 \text{ V}$ , $I_{OUT} = 50 \text{ mA}$	1.746	1.8	1.854	V
Input stability 1	$REG_{IN1}$	$V_{IN} = 2.8 \text{ V} \rightarrow 14.5 \text{ V}$ , $I_{OUT} = 50 \text{ mA}$	—	10	50	mV
Input stability 2	$REG_{IN2}$	$V_{IN} = 2.8 \text{ V} \rightarrow 9 \text{ V}$ , $I_{OUT} = 50 \text{ mA}$	—	5	20	mV
Load stability *1	$REG_{LOA}$	$V_{IN} = 2.8 \text{ V}$ , $I_{OUT} = 0 \text{ mA} \rightarrow 150 \text{ mA}$	—	50	150	mV
Peak output current *2	$I_{PEAK}$	$V_{IN} = 2.8 \text{ V}$ , The output current value decreases by 5% from the value when $V_{OUT}$ is at $I_{OUT} = 50 \text{ mA}$ .	180	240	—	mA
Bias current without load	$I_{BIAS}$	$V_{IN} = 2.8 \text{ V}$ , $I_{OUT} = 0 \text{ mA}$	—	—	350	$\mu\text{A}$
Bias current fluctuation with load	$\Delta I_{BIAS}$	$V_{IN} = 2.8 \text{ V}$ , $I_{OUT} = 0 \text{ mA} \rightarrow 150 \text{ mA}$	—	—	5	mA
Standby consumption current	$I_{STB}$	$V_{IN} = 10 \text{ V}$ , $V_{CONT} = 0 \text{ V}$	—	—	0.1	$\mu\text{A}$
Bias current before starting regulation	$I_{RUSH}$	$V_{IN} = 1.5 \text{ V}$ , $I_{OUT} = 0 \text{ mA}$	—	1.5	5	mA
Ripple rejection ratio	R.R.	$1 \text{ V}_{\text{rms}}$ , $f = 120 \text{ Hz}$ , $I_{OUT} = 10 \text{ mA}$	62	70	—	dB
Minimum input and output voltage difference 1	$V_{DIF(\text{min})1}$	$V_{IN} = 1.5 \text{ V}$ , $I_{OUT} = 0 \text{ mA}$	—	0.1	0.2	V
Minimum input and output voltage difference 2	$V_{DIF(\text{min})2}$	$V_{IN} = 2.1 \text{ V}$ , $I_{OUT} = 150 \text{ mA}$	—	—	0.4	V
Control terminal threshold high voltage	$V_{CONTH}$	$V_{IN} = 2.8 \text{ V}$ , $I_{OUT} = 50 \text{ mA}$	—	—	1.50	V
Control terminal threshold low voltage	$V_{CONTL}$	$V_{IN} = 2.8 \text{ V}$ , $I_{OUT} = 50 \text{ mA}$	0.30	—	—	V
Control terminal current	$I_{CONT}$	$V_{IN} = 2.8 \text{ V}$ , $I_{OUT} = 50 \text{ mA}$ $V_{CONT} = 1.8 \text{ V}$	—	—	30	$\mu\text{A}$

Note) \*1 :  $1.0 \Omega$

\*2 : Peak output current : The output current when the output voltage has been decreased by 5% from the value at the time of the output current is 50 mA due to the overcurrent protection.

## • Design reference data

Note) The following values are typical and not guaranteed values.

Parameter	Symbol	Conditions	Min	Typ	Max	Unit
Output noise voltage	$V_{NO}$	$10\text{Hz} \leq f \leq 100\text{kHz}$ , $I_{OUT} = 10 \text{ mA}$	—	38	—	$\mu\text{V}$
Output voltage temperature coefficient	$\frac{1}{V_{OUT}} \cdot \frac{dV_{OUT}}{dT}$	$V_{IN} = 2.8 \text{ V}$ , $I_{OUT} = 0 \text{ mA}$ $-30^\circ\text{C} \leq T_a \leq +85^\circ\text{C}$	—	90	—	ppm/ $^\circ\text{C}$
Output rise time	$t_{ON}$	$V_{IN} = 2.8 \text{ V}$ , $I_{OUT} = 50 \text{ mA}$ $V_{CONT} = 0 \text{ V} \rightarrow 1.8 \text{ V}$ , $C_{IN} = 0.1 \mu\text{F}$ $C_{OUT} = 10 \mu\text{F}$ , $V_{OUT} = 90\%$	—	0.10	—	ms

Note) \*1 : Refer to ■ Technical Information " • Output rise time characteristics".

## AN80L19RMS (1.9 V)

## ■ Recommended Operating Range

Parameter	Symbol	Range	Unit
Supply voltage	$V_{CC}$	2.3 to 14.5	V

■ Electrical Characteristics at  $T_a = 25^\circ\text{C}$ 

Note) Unless otherwise specially provided, shorten each test time (within 10 ms) so that the test is conducted under the condition that the drift due to the temperature increase in the chip junction part can be neglected.  $C_{IN} = 0.1 \mu\text{F}$ ,  $C_{OUT} = 10 \mu\text{F}$

Parameter	Symbol	Conditions	Min	Typ	Max	Unit
Output voltage	$V_{OUT}$	$V_{IN} = 2.9 \text{ V}$ , $I_{OUT} = 50 \text{ mA}$	1.843	1.9	1.957	V
Input stability 1	$REG_{IN1}$	$V_{IN} = 2.9 \text{ V} \rightarrow 14.5 \text{ V}$ , $I_{OUT} = 50 \text{ mA}$	—	10	50	mV
Input stability 2	$REG_{IN2}$	$V_{IN} = 2.9 \text{ V} \rightarrow 9 \text{ V}$ , $I_{OUT} = 50 \text{ mA}$	—	5	20	mV
Load stability *1	$REG_{LOA}$	$V_{IN} = 2.9 \text{ V}$ , $I_{OUT} = 0 \text{ mA} \rightarrow 150 \text{ mA}$	—	50	150	mV
Peak output current *2	$I_{PEAK}$	$V_{IN} = 2.9 \text{ V}$ , The output current value decreases by 5% from the value when $V_{OUT}$ is at $I_{OUT} = 50 \text{ mA}$ .	180	240	—	mA
Bias current without load	$I_{BIAS}$	$V_{IN} = 2.9 \text{ V}$ , $I_{OUT} = 0 \text{ mA}$	—	—	350	$\mu\text{A}$
Bias current fluctuation with load	$\Delta I_{BIAS}$	$V_{IN} = 2.9 \text{ V}$ , $I_{OUT} = 0 \text{ mA} \rightarrow 150 \text{ mA}$	—	—	5	mA
Standby consumption current	$I_{STB}$	$V_{IN} = 10 \text{ V}$ , $V_{CONT} = 0 \text{ V}$	—	—	0.1	$\mu\text{A}$
Bias current before starting regulation	$I_{RUSH}$	$V_{IN} = 1.6 \text{ V}$ , $I_{OUT} = 0 \text{ mA}$	—	1.5	5	mA
Ripple rejection ratio	R.R.	$1 \text{ V}_{\text{rms}}$ , $f = 120 \text{ Hz}$ , $I_{OUT} = 10 \text{ mA}$	62	70	—	dB
Minimum input and output voltage difference 1	$V_{DIF(\text{min})1}$	$V_{IN} = 1.6 \text{ V}$ , $I_{OUT} = 0 \text{ mA}$	—	0.1	0.2	V
Minimum input and output voltage difference 2	$V_{DIF(\text{min})2}$	$V_{IN} = 2.2 \text{ V}$ , $I_{OUT} = 150 \text{ mA}$	—	—	0.4	V
Control terminal threshold high voltage	$V_{CONTH}$	$V_{IN} = 2.9 \text{ V}$ , $I_{OUT} = 50 \text{ mA}$	—	—	1.50	V
Control terminal threshold high voltage	$V_{CONTH}$	$V_{IN} = 2.9 \text{ V}$ , $I_{OUT} = 50 \text{ mA}$	0.30	—	—	V
Control terminal current	$I_{CONT}$	$V_{IN} = 2.9 \text{ V}$ , $I_{OUT} = 50 \text{ mA}$ $V_{CONT} = 1.8 \text{ V}$	—	—	30	$\mu\text{A}$

Note) \*1 :  $1.0 \Omega$

\*2 : Peak output current : The output current when the output voltage has been decreased by 5% from the value at the time of the output current is 50 mA due to the overcurrent protection.

## • Design reference data

Note) The following values are typical and not guaranteed values.

Parameter	Symbol	Conditions	Min	Typ	Max	Unit
Output noise voltage	$V_{NO}$	$10\text{Hz} \leq f \leq 100\text{kHz}$ , $I_{OUT} = 10 \text{ mA}$	—	40	—	$\mu\text{V}$
Output voltage temperature coefficient	$\frac{1}{V_{OUT}} \cdot \frac{dV_{OUT}}{dT}$	$V_{IN} = 2.9 \text{ V}$ , $I_{OUT} = 0 \text{ mA}$ $-30^\circ\text{C} \leq T_a \leq +85^\circ\text{C}$	—	90	—	ppm/ $^\circ\text{C}$
Output rise time	$t_{ON}$	$V_{IN} = 2.9 \text{ V}$ , $I_{OUT} = 50 \text{ mA}$ $V_{CONT} = 0 \text{ V} \rightarrow 1.8 \text{ V}$ , $C_{IN} = 0.1 \mu\text{F}$ $C_{OUT} = 10 \mu\text{F}$ , $V_{OUT} = 90\%$	—	0.10	—	ms

Note) \*1 : Refer to ■ Technical Information " • Output rise time characteristics".

## AN80L20RMS (2.0 V)

## ■ Recommended Operating Range

Parameter	Symbol	Range	Unit
Supply voltage	$V_{CC}$	2.4 to 14.5	V

■ Electrical Characteristics at  $T_a = 25^\circ\text{C}$ 

Note) Unless otherwise specially provided, shorten each test time (within 10 ms) so that the test is conducted under the condition that the drift due to the temperature increase in the chip junction part can be neglected.  $C_{IN} = 0.1 \mu\text{F}$ ,  $C_{OUT} = 10 \mu\text{F}$

Parameter	Symbol	Conditions	Min	Typ	Max	Unit
Output voltage	$V_{OUT}$	$V_{IN} = 3.0 \text{ V}$ , $I_{OUT} = 50 \text{ mA}$	1.940	2.0	2.060	V
Input stability 1	$REG_{IN1}$	$V_{IN} = 3.0 \text{ V} \rightarrow 14.5 \text{ V}$ , $I_{OUT} = 50 \text{ mA}$	—	10	50	mV
Input stability 2	$REG_{IN2}$	$V_{IN} = 3.0 \text{ V} \rightarrow 9 \text{ V}$ , $I_{OUT} = 50 \text{ mA}$	—	5	20	mV
Load stability *1	$REG_{LOA}$	$V_{IN} = 3.0 \text{ V}$ , $I_{OUT} = 0 \text{ mA} \rightarrow 150 \text{ mA}$	—	50	150	mV
Peak output current *2	$I_{PEAK}$	$V_{IN} = 3.0 \text{ V}$ , The output current value decreases by 5% from the value when $V_{OUT}$ is at $I_{OUT} = 50 \text{ mA}$ .	180	240	—	mA
Bias current without load	$I_{BIAS}$	$V_{IN} = 3.0 \text{ V}$ , $I_{OUT} = 0 \text{ mA}$	—	—	350	$\mu\text{A}$
Bias current fluctuation with load	$\Delta I_{BIAS}$	$V_{IN} = 3.0 \text{ V}$ , $I_{OUT} = 0 \text{ mA} \rightarrow 150 \text{ mA}$	—	—	5	mA
Standby consumption current	$I_{STB}$	$V_{IN} = 10 \text{ V}$ , $V_{CONT} = 0 \text{ V}$	—	—	0.1	$\mu\text{A}$
Bias current before starting regulation	$I_{RUSH}$	$V_{IN} = 1.7 \text{ V}$ , $I_{OUT} = 0 \text{ mA}$	—	1.5	5	mA
Ripple rejection ratio	R.R.	$1 \text{ V}_{\text{rms}}$ , $f = 120 \text{ Hz}$ , $I_{OUT} = 10 \text{ mA}$	62	70	—	dB
Minimum input and output voltage difference 1	$V_{DIF(\text{min})1}$	$V_{IN} = 1.7 \text{ V}$ , $I_{OUT} = 0 \text{ mA}$	—	0.1	0.2	V
Minimum input and output voltage difference 2	$V_{DIF(\text{min})2}$	$V_{IN} = 2.3 \text{ V}$ , $I_{OUT} = 150 \text{ mA}$	—	—	0.4	V
Control terminal threshold high voltage	$V_{CONTH}$	$V_{IN} = 3.0 \text{ V}$ , $I_{OUT} = 50 \text{ mA}$	—	—	1.50	V
Control terminal threshold high voltage	$V_{CONTH}$	$V_{IN} = 3.0 \text{ V}$ , $I_{OUT} = 50 \text{ mA}$	0.30	—	—	V
Control terminal current	$I_{CONT}$	$V_{IN} = 3.0 \text{ V}$ , $I_{OUT} = 50 \text{ mA}$ $V_{CONT} = 1.8 \text{ V}$	—	—	30	$\mu\text{A}$

Note) \*1 :  $1.0 \Omega$

\*2 : Peak output current : The output current when the output voltage has been decreased by 5% from the value at the time of the output current is 50 mA due to the overcurrent protection.

## • Design reference data

Note) The following values are typical and not guaranteed values.

Parameter	Symbol	Conditions	Min	Typ	Max	Unit
Output noise voltage	$V_{NO}$	$10\text{Hz} \leq f \leq 100\text{kHz}$ , $I_{OUT} = 10 \text{ mA}$	—	42	—	$\mu\text{V}$
Output voltage temperature coefficient	$\frac{1}{V_{OUT}} \cdot \frac{dV_{OUT}}{dT}$	$V_{IN} = 3.0 \text{ V}$ , $I_{OUT} = 0 \text{ mA}$ $-30^\circ\text{C} \leq T_a \leq +85^\circ\text{C}$	—	90	—	ppm/ $^\circ\text{C}$
Output rise time	$t_{ON}$	$V_{IN} = 3.0 \text{ V}$ , $I_{OUT} = 50 \text{ mA}$ $V_{CONT} = 0 \text{ V} \rightarrow 1.8 \text{ V}$ , $C_{IN} = 0.1 \mu\text{F}$ $C_{OUT} = 10 \mu\text{F}$ , $V_{OUT} = 90\%$	—	0.10	—	ms

Note) \*1 : Refer to ■ Technical Information " • Output rise time characteristics".

## AN80L21RMS (2.1 V)

## ■ Recommended Operating Range

Parameter	Symbol	Range	Unit
Supply voltage	$V_{CC}$	2.5 to 14.5	V

■ Electrical Characteristics at  $T_a = 25^\circ\text{C}$ 

Note) Unless otherwise specially provided, shorten each test time (within 10 ms) so that the test is conducted under the condition that the drift due to the temperature increase in the chip junction part can be neglected.  $C_{IN} = 0.1 \mu\text{F}$ ,  $C_{OUT} = 10 \mu\text{F}$

Parameter	Symbol	Conditions	Min	Typ	Max	Unit
Output voltage	$V_{OUT}$	$V_{IN} = 3.1 \text{ V}$ , $I_{OUT} = 50 \text{ mA}$	2.037	2.1	2.163	V
Input stability 1	$REG_{IN1}$	$V_{IN} = 3.1 \text{ V} \rightarrow 14.5 \text{ V}$ , $I_{OUT} = 50 \text{ mA}$	—	10	50	mV
Input stability 2	$REG_{IN2}$	$V_{IN} = 3.1 \text{ V} \rightarrow 9 \text{ V}$ , $I_{OUT} = 50 \text{ mA}$	—	5	20	mV
Load stability *1	$REG_{LOA}$	$V_{IN} = 3.1 \text{ V}$ , $I_{OUT} = 0 \text{ mA} \rightarrow 150 \text{ mA}$	—	50	150	mV
Peak output current *2	$I_{PEAK}$	$V_{IN} = 3.1 \text{ V}$ , The output current value decreases by 5% from the value when $V_{OUT}$ is at $I_{OUT} = 50 \text{ mA}$ .	180	240	—	mA
Bias current without load	$I_{BIAS}$	$V_{IN} = 3.1 \text{ V}$ , $I_{OUT} = 0 \text{ mA}$	—	—	350	$\mu\text{A}$
Bias current fluctuation with load	$\Delta I_{BIAS}$	$V_{IN} = 3.1 \text{ V}$ , $I_{OUT} = 0 \text{ mA} \rightarrow 150 \text{ mA}$	—	—	5	mA
Standby consumption current	$I_{STB}$	$V_{IN} = 10 \text{ V}$ , $V_{CONT} = 0 \text{ V}$	—	—	0.1	$\mu\text{A}$
Bias current before starting regulation	$I_{RUSH}$	$V_{IN} = 1.8 \text{ V}$ , $I_{OUT} = 0 \text{ mA}$	—	1.5	5	mA
Ripple rejection ratio	R.R.	$1 \text{ V}_{\text{rms}}$ , $f = 120 \text{ Hz}$ , $I_{OUT} = 10 \text{ mA}$	61	69	—	dB
Minimum input and output voltage difference 1	$V_{DIF(\text{min})1}$	$V_{IN} = 1.8 \text{ V}$ , $I_{OUT} = 0 \text{ mA}$	—	0.1	0.2	V
Minimum input and output voltage difference 2	$V_{DIF(\text{min})2}$	$V_{IN} = 2.4 \text{ V}$ , $I_{OUT} = 150 \text{ mA}$	—	—	0.4	V
Control terminal threshold high voltage	$V_{CONTH}$	$V_{IN} = 3.1 \text{ V}$ , $I_{OUT} = 50 \text{ mA}$	—	—	1.50	V
Control terminal threshold high voltage	$V_{CONTH}$	$V_{IN} = 3.1 \text{ V}$ , $I_{OUT} = 50 \text{ mA}$	0.30	—	—	V
Control terminal current	$I_{CONT}$	$V_{IN} = 3.1 \text{ V}$ , $I_{OUT} = 50 \text{ mA}$ $V_{CONT} = 1.8 \text{ V}$	—	—	30	$\mu\text{A}$

Note) \*1 :  $1.0 \Omega$

\*2 : Peak output current : The output current when the output voltage has been decreased by 5% from the value at the time of the output current is 50 mA due to the overcurrent protection.

## • Design reference data

Note) The following values are typical and not guaranteed values.

Parameter	Symbol	Conditions	Min	Typ	Max	Unit
Output noise voltage	$V_{NO}$	$10\text{Hz} \leq f \leq 100\text{kHz}$ , $I_{OUT} = 10 \text{ mA}$	—	44	—	$\mu\text{V}$
Output voltage temperature coefficient	$\frac{1}{V_{OUT}} \cdot \frac{dV_{OUT}}{dT}$	$V_{IN} = 3.1 \text{ V}$ , $I_{OUT} = 0 \text{ mA}$ $-30^\circ\text{C} \leq T_a \leq +85^\circ\text{C}$	—	90	—	ppm/ $^\circ\text{C}$
Output rise time	$t_{ON}$	$V_{IN} = 3.1 \text{ V}$ , $I_{OUT} = 50 \text{ mA}$ $V_{CONT} = 0 \text{ V} \rightarrow 1.8 \text{ V}$ , $C_{IN} = 0.1 \mu\text{F}$ $C_{OUT} = 10 \mu\text{F}$ , $V_{OUT} = 90\%$	—	0.10	—	ms

Note) \*1 : Refer to ■ Technical Information " • Output rise time characteristics".

## AN80L22RMS (2.2 V)

## ■ Recommended Operating Range

Parameter	Symbol	Range	Unit
Supply voltage	$V_{CC}$	2.6 to 14.5	V

■ Electrical Characteristics at  $T_a = 25^\circ\text{C}$ 

Note) Unless otherwise specially provided, shorten each test time (within 10 ms) so that the test is conducted under the condition that the drift due to the temperature increase in the chip junction part can be neglected.  $C_{IN} = 0.1 \mu\text{F}$ ,  $C_{OUT} = 10 \mu\text{F}$

Parameter	Symbol	Conditions	Min	Typ	Max	Unit
Output voltage	$V_{OUT}$	$V_{IN} = 3.2 \text{ V}$ , $I_{OUT} = 50 \text{ mA}$	2.134	2.2	2.266	V
Input stability 1	$REG_{IN1}$	$V_{IN} = 3.2 \text{ V} \rightarrow 14.5 \text{ V}$ , $I_{OUT} = 50 \text{ mA}$	—	10	50	mV
Input stability 2	$REG_{IN2}$	$V_{IN} = 3.2 \text{ V} \rightarrow 9 \text{ V}$ , $I_{OUT} = 50 \text{ mA}$	—	5	20	mV
Load stability *1	$REG_{LOA}$	$V_{IN} = 3.2 \text{ V}$ , $I_{OUT} = 0 \text{ mA} \rightarrow 150 \text{ mA}$	—	50	150	mV
Peak output current *2	$I_{PEAK}$	$V_{IN} = 3.2 \text{ V}$ , The output current value decreases by 5% from the value when $V_{OUT}$ is at $I_{OUT} = 50 \text{ mA}$ .	180	240	—	mA
Bias current without load	$I_{BIAS}$	$V_{IN} = 3.2 \text{ V}$ , $I_{OUT} = 0 \text{ mA}$	—	—	350	$\mu\text{A}$
Bias current fluctuation with load	$\Delta I_{BIAS}$	$V_{IN} = 3.2 \text{ V}$ , $I_{OUT} = 0 \text{ mA} \rightarrow 150 \text{ mA}$	—	—	5	mA
Standby consumption current	$I_{STB}$	$V_{IN} = 10 \text{ V}$ , $V_{CONT} = 0 \text{ V}$	—	—	0.1	$\mu\text{A}$
Bias current before starting regulation	$I_{RUSH}$	$V_{IN} = 1.9 \text{ V}$ , $I_{OUT} = 0 \text{ mA}$	—	1.5	5	mA
Ripple rejection ratio	R.R.	$1 \text{ V}_{\text{rms}}$ , $f = 120 \text{ Hz}$ , $I_{OUT} = 10 \text{ mA}$	61	69	—	dB
Minimum input and output voltage difference 1	$V_{DIF(\text{min})1}$	$V_{IN} = 1.9 \text{ V}$ , $I_{OUT} = 0 \text{ mA}$	—	0.1	0.2	V
Minimum input and output voltage difference 2	$V_{DIF(\text{min})2}$	$V_{IN} = 2.4 \text{ V}$ , $I_{OUT} = 150 \text{ mA}$	—	—	0.4	V
Control terminal threshold high voltage	$V_{CONTH}$	$V_{IN} = 3.2 \text{ V}$ , $I_{OUT} = 50 \text{ mA}$	—	—	1.50	V
Control terminal threshold high voltage	$V_{CONTH}$	$V_{IN} = 3.2 \text{ V}$ , $I_{OUT} = 50 \text{ mA}$	0.30	—	—	V
Control terminal current	$I_{CONT}$	$V_{IN} = 3.2 \text{ V}$ , $I_{OUT} = 50 \text{ mA}$ $V_{CONT} = 1.8 \text{ V}$	—	—	30	$\mu\text{A}$

Note) \*1 :  $1.0 \Omega$

\*2 : Peak output current : The output current when the output voltage has been decreased by 5% from the value at the time of the output current is 50 mA due to the overcurrent protection.

## • Design reference data

Note) The following values are typical and not guaranteed values.

Parameter	Symbol	Conditions	Min	Typ	Max	Unit
Output noise voltage	$V_{NO}$	$10\text{Hz} \leq f \leq 100\text{kHz}$ , $I_{OUT} = 10 \text{ mA}$	—	46	—	$\mu\text{V}$
Output voltage temperature coefficient	$\frac{1}{V_{OUT}} \cdot \frac{dV_{OUT}}{dT}$	$V_{IN} = 3.2 \text{ V}$ , $I_{OUT} = 0 \text{ mA}$ $-30^\circ\text{C} \leq T_a \leq +85^\circ\text{C}$	—	90	—	ppm/ $^\circ\text{C}$
Output rise time	$t_{ON}$	$V_{IN} = 3.2 \text{ V}$ , $I_{OUT} = 50 \text{ mA}$ $V_{CONT} = 0 \text{ V} \rightarrow 1.8 \text{ V}$ , $C_{IN} = 0.1 \mu\text{F}$ $C_{OUT} = 10 \mu\text{F}$ , $V_{OUT} = 90\%$	—	0.10	—	ms

Note) \*1 : Refer to ■ Technical Information " • Output rise time characteristics".

## AN80L25RMS (2.5 V)

## ■ Recommended Operating Range

Parameter	Symbol	Range	Unit
Supply voltage	$V_{CC}$	2.9 to 14.5	V

■ Electrical Characteristics at  $T_a = 25^\circ\text{C}$ 

Note) Unless otherwise specially provided, shorten each test time (within 10 ms) so that the test is conducted under the condition that the drift due to the temperature increase in the chip junction part can be neglected.  $C_{IN} = 0.1 \mu\text{F}$ ,  $C_{OUT} = 10 \mu\text{F}$

Parameter	Symbol	Conditions	Min	Typ	Max	Unit
Output voltage	$V_{OUT}$	$V_{IN} = 3.5 \text{ V}$ , $I_{OUT} = 50 \text{ mA}$	2.425	2.5	2.575	V
Input stability 1	$REG_{IN1}$	$V_{IN} = 3.5 \text{ V} \rightarrow 14.5 \text{ V}$ , $I_{OUT} = 50 \text{ mA}$	—	10	50	mV
Input stability 2	$REG_{IN2}$	$V_{IN} = 3.5 \text{ V} \rightarrow 9 \text{ V}$ , $I_{OUT} = 50 \text{ mA}$	—	5	20	mV
Load stability *1	$REG_{LOA}$	$V_{IN} = 3.5 \text{ V}$ , $I_{OUT} = 0 \text{ mA} \rightarrow 150 \text{ mA}$	—	50	150	mV
Peak output current *2	$I_{PEAK}$	$V_{IN} = 3.5 \text{ V}$ , The output current value decreases by 5% from the value when $V_{OUT}$ is at $I_{OUT} = 50 \text{ mA}$ .	180	240	—	mA
Bias current without load	$I_{BIAS}$	$V_{IN} = 3.5 \text{ V}$ , $I_{OUT} = 0 \text{ mA}$	—	—	350	$\mu\text{A}$
Bias current fluctuation with load	$\Delta I_{BIAS}$	$V_{IN} = 3.5 \text{ V}$ , $I_{OUT} = 0 \text{ mA} \rightarrow 150 \text{ mA}$	—	—	5	mA
Standby consumption current	$I_{STB}$	$V_{IN} = 10 \text{ V}$ , $V_{CONT} = 0 \text{ V}$	—	—	0.1	$\mu\text{A}$
Bias current before starting regulation	$I_{RUSH}$	$V_{IN} = 2.2 \text{ V}$ , $I_{OUT} = 0 \text{ mA}$	—	1.5	5	mA
Ripple rejection ratio	R.R.	$1 \text{ V}_{\text{rms}}$ , $f = 120 \text{ Hz}$ , $I_{OUT} = 10 \text{ mA}$	60	68	—	dB
Minimum input and output voltage difference 1	$V_{DIF(\text{min})1}$	$V_{IN} = 2.2 \text{ V}$ , $I_{OUT} = 0 \text{ mA}$	—	0.1	0.2	V
Minimum input and output voltage difference 2	$V_{DIF(\text{min})2}$	$V_{IN} = 2.6 \text{ V}$ , $I_{OUT} = 150 \text{ mA}$	—	—	0.4	V
Control terminal threshold high voltage	$V_{CONTH}$	$V_{IN} = 3.5 \text{ V}$ , $I_{OUT} = 50 \text{ mA}$	—	—	1.50	V
Control terminal threshold high voltage	$V_{CONTH}$	$V_{IN} = 3.5 \text{ V}$ , $I_{OUT} = 50 \text{ mA}$	0.30	—	—	V
Control terminal current	$I_{CONT}$	$V_{IN} = 3.5 \text{ V}$ , $I_{OUT} = 50 \text{ mA}$ $V_{CONT} = 1.8 \text{ V}$	—	—	30	$\mu\text{A}$

Note) \*1 :  $1.0 \Omega$

\*2 : Peak output current : The output current when the output voltage has been decreased by 5% from the value at the time of the output current is 50 mA due to the overcurrent protection.

## • Design reference data

Note) The following values are typical and not guaranteed values.

Parameter	Symbol	Conditions	Min	Typ	Max	Unit
Output noise voltage	$V_{NO}$	$10\text{Hz} \leq f \leq 100\text{kHz}$ , $I_{OUT} = 10 \text{ mA}$	—	58	—	$\mu\text{V}$
Output voltage temperature coefficient	$\frac{1}{V_{OUT}} \cdot \frac{dV_{OUT}}{dT}$	$V_{IN} = 3.5 \text{ V}$ , $I_{OUT} = 0 \text{ mA}$ $-30^\circ\text{C} \leq T_a \leq +85^\circ\text{C}$	—	90	—	ppm/ $^\circ\text{C}$
Output rise time	$t_{ON}$	$V_{IN} = 3.15 \text{ V}$ , $I_{OUT} = 50 \text{ mA}$ $V_{CONT} = 0 \text{ V} \rightarrow 1.8 \text{ V}$ , $C_{IN} = 0.1 \mu\text{F}$ $C_{OUT} = 10 \mu\text{F}$ , $V_{OUT} = 90\%$	—	0.10	—	ms

Note) \*1 : Refer to ■ Technical Information " • Output rise time characteristics".

## AN80L28RMS (2.8 V)

## ■ Recommended Operating Range

Parameter	Symbol	Range	Unit
Supply voltage	$V_{CC}$	3.2 to 14.5	V

■ Electrical Characteristics at  $T_a = 25^\circ\text{C}$ 

Note) Unless otherwise specially provided, shorten each test time (within 10 ms) so that the test is conducted under the condition that the drift due to the temperature increase in the chip junction part can be neglected.  $C_{IN} = 0.1 \mu\text{F}$ ,  $C_{OUT} = 10 \mu\text{F}$

Parameter	Symbol	Conditions	Min	Typ	Max	Unit
Output voltage	$V_{OUT}$	$V_{IN} = 3.8 \text{ V}$ , $I_{OUT} = 50 \text{ mA}$	2.716	2.8	2.884	V
Input stability 1	$REG_{IN1}$	$V_{IN} = 3.8 \text{ V} \rightarrow 14.5 \text{ V}$ , $I_{OUT} = 50 \text{ mA}$	—	10	50	mV
Input stability 2	$REG_{IN2}$	$V_{IN} = 3.8 \text{ V} \rightarrow 9 \text{ V}$ , $I_{OUT} = 50 \text{ mA}$	—	5	20	mV
Load stability *1	$REG_{LOA}$	$V_{IN} = 3.8 \text{ V}$ , $I_{OUT} = 0 \text{ mA} \rightarrow 150 \text{ mA}$	—	50	150	mV
Peak output current *2	$I_{PEAK}$	$V_{IN} = 3.8 \text{ V}$ , The output current value decreases by 5% from the value when $V_{OUT}$ is at $I_{OUT} = 50 \text{ mA}$ .	180	240	—	mA
Bias current without load	$I_{BIAS}$	$V_{IN} = 3.8 \text{ V}$ , $I_{OUT} = 0 \text{ mA}$	—	—	350	$\mu\text{A}$
Bias current fluctuation with load	$\Delta I_{BIAS}$	$V_{IN} = 3.8 \text{ V}$ , $I_{OUT} = 0 \text{ mA} \rightarrow 150 \text{ mA}$	—	—	5	mA
Standby consumption current	$I_{STB}$	$V_{IN} = 10 \text{ V}$ , $V_{CONT} = 0 \text{ V}$	—	—	0.1	$\mu\text{A}$
Bias current before starting regulation	$I_{RUSH}$	$V_{IN} = 2.5 \text{ V}$ , $I_{OUT} = 0 \text{ mA}$	—	1.5	5	mA
Ripple rejection ratio	R.R.	$1 \text{ V}_{\text{rms}}$ , $f = 120 \text{ Hz}$ , $I_{OUT} = 10 \text{ mA}$	60	68	—	dB
Minimum input and output voltage difference 1	$V_{DIF(\text{min})1}$	$V_{IN} = 2.5 \text{ V}$ , $I_{OUT} = 0 \text{ mA}$	—	0.1	0.2	V
Minimum input and output voltage difference 2	$V_{DIF(\text{min})2}$	$V_{IN} = 2.9 \text{ V}$ , $I_{OUT} = 150 \text{ mA}$	—	—	0.4	V
Control terminal threshold high voltage	$V_{CONTH}$	$V_{IN} = 3.8 \text{ V}$ , $I_{OUT} = 50 \text{ mA}$	—	—	1.50	V
Control terminal threshold high voltage	$V_{CONTH}$	$V_{IN} = 3.8 \text{ V}$ , $I_{OUT} = 50 \text{ mA}$	0.30	—	—	V
Control terminal current	$I_{CONT}$	$V_{IN} = 3.8 \text{ V}$ , $I_{OUT} = 50 \text{ mA}$ $V_{CONT} = 1.8 \text{ V}$	—	—	30	$\mu\text{A}$

Note) \*1 :  $1.0 \Omega$

\*2 : Peak output current : The output current when the output voltage has been decreased by 5% from the value at the time of the output current is 50 mA due to the overcurrent protection.

## • Design reference data

Note) The following values are typical and not guaranteed values.

Parameter	Symbol	Conditions	Min	Typ	Max	Unit
Output noise voltage	$V_{NO}$	$10\text{Hz} \leq f \leq 100\text{kHz}$ , $I_{OUT} = 10 \text{ mA}$	—	58	—	$\mu\text{V}$
Output voltage temperature coefficient	$\frac{1}{V_{OUT}} \cdot \frac{dV_{OUT}}{dT}$	$V_{IN} = 3.8 \text{ V}$ , $I_{OUT} = 0 \text{ mA}$ $-30^\circ\text{C} \leq T_a \leq +85^\circ\text{C}$	—	90	—	ppm/ $^\circ\text{C}$
Output rise time	$t_{ON}$	$V_{IN} = 3.8 \text{ V}$ , $I_{OUT} = 50 \text{ mA}$ $V_{CONT} = 0 \text{ V} \rightarrow 1.8 \text{ V}$ , $C_{IN} = 0.1 \mu\text{F}$ $C_{OUT} = 10 \mu\text{F}$ , $V_{OUT} = 90\%$	—	0.10	—	ms

Note) \*1 : Refer to ■ Technical Information " • Output rise time characteristics".

## AN80L29RMS (2.9 V)

## ■ Recommended Operating Range

Parameter	Symbol	Range	Unit
Supply voltage	$V_{CC}$	3.3 to 14.5	V

■ Electrical Characteristics at  $T_a = 25^\circ\text{C}$ 

Note) Unless otherwise specially provided, shorten each test time (within 10 ms) so that the test is conducted under the condition that the drift due to the temperature increase in the chip junction part can be neglected.  $C_{IN} = 0.1 \mu\text{F}$ ,  $C_{OUT} = 10 \mu\text{F}$

Parameter	Symbol	Conditions	Min	Typ	Max	Unit
Output voltage	$V_{OUT}$	$V_{IN} = 3.9 \text{ V}$ , $I_{OUT} = 50 \text{ mA}$	2.813	2.9	2.987	V
Input stability 1	$REG_{IN1}$	$V_{IN} = 3.9 \text{ V} \rightarrow 14.5 \text{ V}$ , $I_{OUT} = 50 \text{ mA}$	—	10	50	mV
Input stability 2	$REG_{IN2}$	$V_{IN} = 3.9 \text{ V} \rightarrow 9 \text{ V}$ , $I_{OUT} = 50 \text{ mA}$	—	5	20	mV
Load stability *1	$REG_{LOA}$	$V_{IN} = 3.9 \text{ V}$ , $I_{OUT} = 0 \text{ mA} \rightarrow 150 \text{ mA}$	—	50	150	mV
Peak output current *2	$I_{PEAK}$	$V_{IN} = 3.9 \text{ V}$ , The output current value decreases by 5% from the value when $V_{OUT}$ is at $I_{OUT} = 50 \text{ mA}$ .	180	240	—	mA
Bias current without load	$I_{BIAS}$	$V_{IN} = 3.9 \text{ V}$ , $I_{OUT} = 0 \text{ mA}$	—	—	350	$\mu\text{A}$
Bias current fluctuation with load	$\Delta I_{BIAS}$	$V_{IN} = 3.9 \text{ V}$ , $I_{OUT} = 0 \text{ mA} \rightarrow 150 \text{ mA}$	—	—	5	mA
Standby consumption current	$I_{STB}$	$V_{IN} = 10 \text{ V}$ , $V_{CONT} = 0 \text{ V}$	—	—	0.1	$\mu\text{A}$
Bias current before starting regulation	$I_{RUSH}$	$V_{IN} = 2.6 \text{ V}$ , $I_{OUT} = 0 \text{ mA}$	—	1.5	5	mA
Ripple rejection ratio	R.R.	$1 \text{ V}_{\text{rms}}$ , $f = 120 \text{ Hz}$ , $I_{OUT} = 10 \text{ mA}$	60	68	—	dB
Minimum input and output voltage difference 1	$V_{DIF(\text{min})1}$	$V_{IN} = 2.6 \text{ V}$ , $I_{OUT} = 0 \text{ mA}$	—	0.1	0.2	V
Minimum input and output voltage difference 2	$V_{DIF(\text{min})2}$	$V_{IN} = 3.0 \text{ V}$ , $I_{OUT} = 150 \text{ mA}$	—	—	0.4	V
Control terminal threshold high voltage	$V_{CONTH}$	$V_{IN} = 3.9 \text{ V}$ , $I_{OUT} = 50 \text{ mA}$	—	—	1.50	V
Control terminal threshold high voltage	$V_{CONTH}$	$V_{IN} = 3.9 \text{ V}$ , $I_{OUT} = 50 \text{ mA}$	0.30	—	—	V
Control terminal current	$I_{CONT}$	$V_{IN} = 3.9 \text{ V}$ , $I_{OUT} = 50 \text{ mA}$ $V_{CONT} = 1.8 \text{ V}$	—	—	30	$\mu\text{A}$

Note) \*1 :  $1.0 \Omega$

\*2 : Peak output current : The output current when the output voltage has been decreased by 5% from the value at the time of the output current is 50 mA due to the overcurrent protection.

## • Design reference data

Note) The following values are typical and not guaranteed values.

Parameter	Symbol	Conditions	Min	Typ	Max	Unit
Output noise voltage	$V_{NO}$	$10\text{Hz} \leq f \leq 100\text{kHz}$ , $I_{OUT} = 10 \text{ mA}$	—	60	—	$\mu\text{V}$
Output voltage temperature coefficient	$\frac{1}{V_{OUT}} \cdot \frac{dV_{OUT}}{dT}$	$V_{IN} = 3.9 \text{ V}$ , $I_{OUT} = 0 \text{ mA}$ $-30^\circ\text{C} \leq T_a \leq +85^\circ\text{C}$	—	90	—	ppm/ $^\circ\text{C}$
Output rise time	$t_{ON}$	$V_{IN} = 3.9 \text{ V}$ , $I_{OUT} = 50 \text{ mA}$ $V_{CONT} = 0 \text{ V} \rightarrow 1.8 \text{ V}$ , $C_{IN} = 0.1 \mu\text{F}$ $C_{OUT} = 10 \mu\text{F}$ , $V_{OUT} = 90\%$	—	0.12	—	ms

Note) \*1 : Refer to ■ Technical Information " • Output rise time characteristics".

## AN80L30RMS (3.0 V)

## ■ Recommended Operating Range

Parameter	Symbol	Range	Unit
Supply voltage	$V_{CC}$	3.4 to 14.5	V

■ Electrical Characteristics at  $T_a = 25^\circ\text{C}$ 

Note) Unless otherwise specially provided, shorten each test time (within 10 ms) so that the test is conducted under the condition that the drift due to the temperature increase in the chip junction part can be neglected.  $C_{IN} = 0.1 \mu\text{F}$ ,  $C_{OUT} = 10 \mu\text{F}$

Parameter	Symbol	Conditions	Min	Typ	Max	Unit
Output voltage	$V_{OUT}$	$V_{IN} = 4.0 \text{ V}$ , $I_{OUT} = 50 \text{ mA}$	2.910	3.0	3.090	V
Input stability 1	$REG_{IN1}$	$V_{IN} = 4.0 \text{ V} \rightarrow 14.5 \text{ V}$ , $I_{OUT} = 50 \text{ mA}$	—	10	50	mV
Input stability 2	$REG_{IN2}$	$V_{IN} = 4.0 \text{ V} \rightarrow 9 \text{ V}$ , $I_{OUT} = 50 \text{ mA}$	—	5	20	mV
Load stability *1	$REG_{LOA}$	$V_{IN} = 4.0 \text{ V}$ , $I_{OUT} = 0 \text{ mA} \rightarrow 150 \text{ mA}$	—	50	150	mV
Peak output current *2	$I_{PEAK}$	$V_{IN} = 4.0 \text{ V}$ , The output current value decreases by 5% from the value when $V_{OUT}$ is at $I_{OUT} = 50 \text{ mA}$ .	180	240	—	mA
Bias current without load	$I_{BIAS}$	$V_{IN} = 4.0 \text{ V}$ , $I_{OUT} = 0 \text{ mA}$	—	—	350	$\mu\text{A}$
Bias current fluctuation with load	$\Delta I_{BIAS}$	$V_{IN} = 4.0 \text{ V}$ , $I_{OUT} = 0 \text{ mA} \rightarrow 150 \text{ mA}$	—	—	5	mA
Standby consumption current	$I_{STB}$	$V_{IN} = 10 \text{ V}$ , $V_{CONT} = 0 \text{ V}$	—	—	0.1	$\mu\text{A}$
Bias current before starting regulation	$I_{RUSH}$	$V_{IN} = 2.7 \text{ V}$ , $I_{OUT} = 0 \text{ mA}$	—	1.5	5	mA
Ripple rejection ratio	R.R.	$1 \text{ V}_{\text{rms}}$ , $f = 120 \text{ Hz}$ , $I_{OUT} = 10 \text{ mA}$	60	68	—	dB
Minimum input and output voltage difference 1	$V_{DIF(\text{min})1}$	$V_{IN} = 2.7 \text{ V}$ , $I_{OUT} = 0 \text{ mA}$	—	0.1	0.2	V
Minimum input and output voltage difference 2	$V_{DIF(\text{min})2}$	$V_{IN} = 3.1 \text{ V}$ , $I_{OUT} = 150 \text{ mA}$	—	—	0.4	V
Control terminal threshold high voltage	$V_{CONTH}$	$V_{IN} = 4.0 \text{ V}$ , $I_{OUT} = 50 \text{ mA}$	—	—	1.50	V
Control terminal threshold high voltage	$V_{CONTH}$	$V_{IN} = 4.0 \text{ V}$ , $I_{OUT} = 50 \text{ mA}$	0.30	—	—	V
Control terminal current	$I_{CONT}$	$V_{IN} = 4.0 \text{ V}$ , $I_{OUT} = 50 \text{ mA}$ $V_{CONT} = 1.8 \text{ V}$	—	—	30	$\mu\text{A}$

Note) \*1 :  $1.0 \Omega$

\*2 : Peak output current : The output current when the output voltage has been decreased by 5% from the value at the time of the output current is 50 mA due to the overcurrent protection.

## • Design reference data

Note) The following values are typical and not guaranteed values.

Parameter	Symbol	Conditions	Min	Typ	Max	Unit
Output noise voltage	$V_{NO}$	$10\text{Hz} \leq f \leq 100\text{kHz}$ , $I_{OUT} = 10 \text{ mA}$	—	62	—	$\mu\text{V}$
Output voltage temperature coefficient	$\frac{1}{V_{OUT}} \cdot \frac{dV_{OUT}}{dT}$	$V_{IN} = 4.0 \text{ V}$ , $I_{OUT} = 0 \text{ mA}$ $-30^\circ\text{C} \leq T_a \leq +85^\circ\text{C}$	—	90	—	ppm/ $^\circ\text{C}$
Output rise time	$t_{ON}$	$V_{IN} = 4.0 \text{ V}$ , $I_{OUT} = 50 \text{ mA}$ $V_{CONT} = 0 \text{ V} \rightarrow 1.8 \text{ V}$ , $C_{IN} = 0.1 \mu\text{F}$ $C_{OUT} = 10 \mu\text{F}$ , $V_{OUT} = 90\%$	—	0.12	—	ms

Note) \*1 : Refer to ■ Technical Information " • Output rise time characteristics".

## AN80L31RMS (3.1 V)

## ■ Recommended Operating Range

Parameter	Symbol	Range	Unit
Supply voltage	$V_{CC}$	3.5 to 14.5	V

■ Electrical Characteristics at  $T_a = 25^\circ\text{C}$ 

Note) Unless otherwise specially provided, shorten each test time (within 10 ms) so that the test is conducted under the condition that the drift due to the temperature increase in the chip junction part can be neglected.  $C_{IN} = 0.1 \mu\text{F}$ ,  $C_{OUT} = 10 \mu\text{F}$

Parameter	Symbol	Conditions	Min	Typ	Max	Unit
Output voltage	$V_{OUT}$	$V_{IN} = 4.1 \text{ V}$ , $I_{OUT} = 50 \text{ mA}$	3.007	3.1	3.193	V
Input stability 1	$REG_{IN1}$	$V_{IN} = 4.1 \text{ V} \rightarrow 14.5 \text{ V}$ , $I_{OUT} = 50 \text{ mA}$	—	10	50	mV
Input stability 2	$REG_{IN2}$	$V_{IN} = 4.1 \text{ V} \rightarrow 9 \text{ V}$ , $I_{OUT} = 50 \text{ mA}$	—	5	20	mV
Load stability *1	$REG_{LOA}$	$V_{IN} = 4.1 \text{ V}$ , $I_{OUT} = 0 \text{ mA} \rightarrow 150 \text{ mA}$	—	50	150	mV
Peak output current *2	$I_{PEAK}$	$V_{IN} = 4.1 \text{ V}$ , The output current value decreases by 5% from the value when $V_{OUT}$ is at $I_{OUT} = 50 \text{ mA}$ .	180	240	—	mA
Bias current without load	$I_{BIAS}$	$V_{IN} = 4.1 \text{ V}$ , $I_{OUT} = 0 \text{ mA}$	—	—	350	$\mu\text{A}$
Bias current fluctuation with load	$\Delta I_{BIAS}$	$V_{IN} = 4.1 \text{ V}$ , $I_{OUT} = 0 \text{ mA} \rightarrow 150 \text{ mA}$	—	—	5	mA
Standby consumption current	$I_{STB}$	$V_{IN} = 10 \text{ V}$ , $V_{CONT} = 0 \text{ V}$	—	—	0.1	$\mu\text{A}$
Bias current before starting regulation	$I_{RUSH}$	$V_{IN} = 2.8 \text{ V}$ , $I_{OUT} = 0 \text{ mA}$	—	1.5	5	mA
Ripple rejection ratio	R.R.	$1 \text{ V}_{\text{rms}}$ , $f = 120 \text{ Hz}$ , $I_{OUT} = 10 \text{ mA}$	59	67	—	dB
Minimum input and output voltage difference 1	$V_{DIF(\text{min})1}$	$V_{IN} = 2.8 \text{ V}$ , $I_{OUT} = 0 \text{ mA}$	—	0.1	0.2	V
Minimum input and output voltage difference 2	$V_{DIF(\text{min})2}$	$V_{IN} = 3.2 \text{ V}$ , $I_{OUT} = 150 \text{ mA}$	—	—	0.4	V
Control terminal threshold high voltage	$V_{CONTH}$	$V_{IN} = 4.1 \text{ V}$ , $I_{OUT} = 50 \text{ mA}$	—	—	1.50	V
Control terminal threshold high voltage	$V_{CONTH}$	$V_{IN} = 4.1 \text{ V}$ , $I_{OUT} = 50 \text{ mA}$	0.30	—	—	V
Control terminal current	$I_{CONT}$	$V_{IN} = 4.1 \text{ V}$ , $I_{OUT} = 50 \text{ mA}$ $V_{CONT} = 1.8 \text{ V}$	—	—	30	$\mu\text{A}$

Note) \*1 :  $1.0 \Omega$

\*2 : Peak output current : The output current when the output voltage has been decreased by 5% from the value at the time of the output current is 50 mA due to the overcurrent protection.

## • Design reference data

Note) The following values are typical and not guaranteed values.

Parameter	Symbol	Conditions	Min	Typ	Max	Unit
Output noise voltage	$V_{NO}$	$10\text{Hz} \leq f \leq 100\text{kHz}$ , $I_{OUT} = 10 \text{ mA}$	—	64	—	$\mu\text{V}$
Output voltage temperature coefficient	$\frac{1}{V_{OUT}} \cdot \frac{dV_{OUT}}{dT}$	$V_{IN} = 4.1 \text{ V}$ , $I_{OUT} = 0 \text{ mA}$ $-30^\circ\text{C} \leq T_a \leq +85^\circ\text{C}$	—	90	—	ppm/ $^\circ\text{C}$
Output rise time	$t_{ON}$	$V_{IN} = 4.1 \text{ V}$ , $I_{OUT} = 50 \text{ mA}$ $V_{CONT} = 0 \text{ V} \rightarrow 1.8 \text{ V}$ , $C_{IN} = 0.1 \mu\text{F}$ $C_{OUT} = 10 \mu\text{F}$ , $V_{OUT} = 90\%$	—	0.12	—	ms

Note) \*1 : Refer to ■ Technical Information " • Output rise time characteristics".

## AN80L32RMS (3.2 V)

## ■ Recommended Operating Range

Parameter	Symbol	Range	Unit
Supply voltage	$V_{CC}$	3.6 to 14.5	V

■ Electrical Characteristics at  $T_a = 25^\circ\text{C}$ 

Note) Unless otherwise specially provided, shorten each test time (within 10 ms) so that the test is conducted under the condition that the drift due to the temperature increase in the chip junction part can be neglected.  $C_{IN} = 0.1 \mu\text{F}$ ,  $C_{OUT} = 10 \mu\text{F}$

Parameter	Symbol	Conditions	Min	Typ	Max	Unit
Output voltage	$V_{OUT}$	$V_{IN} = 4.2 \text{ V}$ , $I_{OUT} = 50 \text{ mA}$	3.104	3.2	3.296	V
Input stability 1	$REG_{IN1}$	$V_{IN} = 4.2 \text{ V} \rightarrow 14.5 \text{ V}$ , $I_{OUT} = 50 \text{ mA}$	—	10	50	mV
Input stability 2	$REG_{IN2}$	$V_{IN} = 4.2 \text{ V} \rightarrow 9 \text{ V}$ , $I_{OUT} = 50 \text{ mA}$	—	5	20	mV
Load stability *1	$REG_{LOA}$	$V_{IN} = 4.2 \text{ V}$ , $I_{OUT} = 0 \text{ mA} \rightarrow 150 \text{ mA}$	—	50	150	mV
Peak output current *2	$I_{PEAK}$	$V_{IN} = 4.2 \text{ V}$ , The output current value decreases by 5% from the value when $V_{OUT}$ is at $I_{OUT} = 50 \text{ mA}$ .	180	240	—	mA
Bias current without load	$I_{BIAS}$	$V_{IN} = 4.2 \text{ V}$ , $I_{OUT} = 0 \text{ mA}$	—	—	350	$\mu\text{A}$
Bias current fluctuation with load	$\Delta I_{BIAS}$	$V_{IN} = 4.2 \text{ V}$ , $I_{OUT} = 0 \text{ mA} \rightarrow 150 \text{ mA}$	—	—	5	mA
Standby consumption current	$I_{STB}$	$V_{IN} = 10 \text{ V}$ , $V_{CONT} = 0 \text{ V}$	—	—	0.1	$\mu\text{A}$
Bias current before starting regulation	$I_{RUSH}$	$V_{IN} = 2.9 \text{ V}$ , $I_{OUT} = 0 \text{ mA}$	—	1.5	5	mA
Ripple rejection ratio	R.R.	$1 \text{ V}_{\text{rms}}$ , $f = 120 \text{ Hz}$ , $I_{OUT} = 10 \text{ mA}$	59	67	—	dB
Minimum input and output voltage difference 1	$V_{DIF(\text{min})1}$	$V_{IN} = 2.9 \text{ V}$ , $I_{OUT} = 0 \text{ mA}$	—	0.1	0.2	V
Minimum input and output voltage difference 2	$V_{DIF(\text{min})2}$	$V_{IN} = 3.3 \text{ V}$ , $I_{OUT} = 150 \text{ mA}$	—	—	0.4	V
Control terminal threshold high voltage	$V_{CONTH}$	$V_{IN} = 4.2 \text{ V}$ , $I_{OUT} = 50 \text{ mA}$	—	—	1.50	V
Control terminal threshold high voltage	$V_{CONTH}$	$V_{IN} = 4.2 \text{ V}$ , $I_{OUT} = 50 \text{ mA}$	0.30	—	—	V
Control terminal current	$I_{CONT}$	$V_{IN} = 4.2 \text{ V}$ , $I_{OUT} = 50 \text{ mA}$ $V_{CONT} = 1.8 \text{ V}$	—	—	30	$\mu\text{A}$

Note) \*1 :  $1.0 \Omega$

\*2 : Peak output current : The output current when the output voltage has been decreased by 5% from the value at the time of the output current is 50 mA due to the overcurrent protection.

## • Design reference data

Note) The following values are typical and not guaranteed values.

Parameter	Symbol	Conditions	Min	Typ	Max	Unit
Output noise voltage	$V_{NO}$	$10\text{Hz} \leq f \leq 100\text{kHz}$ , $I_{OUT} = 10 \text{ mA}$	—	66	—	$\mu\text{V}$
Output voltage temperature coefficient	$\frac{1}{V_{OUT}} \cdot \frac{dV_{OUT}}{dT}$	$V_{IN} = 4.2 \text{ V}$ , $I_{OUT} = 0 \text{ mA}$ $-30^\circ\text{C} \leq T_a \leq +85^\circ\text{C}$	—	90	—	ppm/ $^\circ\text{C}$
Output rise time	$t_{ON}$	$V_{IN} = 4.2 \text{ V}$ , $I_{OUT} = 50 \text{ mA}$ $V_{CONT} = 0 \text{ V} \rightarrow 1.8 \text{ V}$ , $C_{IN} = 0.1 \mu\text{F}$ $C_{OUT} = 10 \mu\text{F}$ , $V_{OUT} = 90\%$	—	0.12	—	ms

Note) \*1 : Refer to ■ Technical Information " • Output rise time characteristics".

## AN80L33RMS (3.3 V)

## ■ Recommended Operating Range

Parameter	Symbol	Range	Unit
Supply voltage	$V_{CC}$	3.7 to 14.5	V

■ Electrical Characteristics at  $T_a = 25^\circ\text{C}$ 

Note) Unless otherwise specially provided, shorten each test time (within 10 ms) so that the test is conducted under the condition that the drift due to the temperature increase in the chip junction part can be neglected.  $C_{IN} = 0.1 \mu\text{F}$ ,  $C_{OUT} = 10 \mu\text{F}$

Parameter	Symbol	Conditions	Min	Typ	Max	Unit
Output voltage	$V_{OUT}$	$V_{IN} = 4.3 \text{ V}$ , $I_{OUT} = 50 \text{ mA}$	3.201	3.3	3.399	V
Input stability 1	$REG_{IN1}$	$V_{IN} = 4.3 \text{ V} \rightarrow 14.5 \text{ V}$ , $I_{OUT} = 50 \text{ mA}$	—	10	50	mV
Input stability 2	$REG_{IN2}$	$V_{IN} = 4.3 \text{ V} \rightarrow 9 \text{ V}$ , $I_{OUT} = 50 \text{ mA}$	—	5	20	mV
Load stability *1	$REG_{LOA}$	$V_{IN} = 4.3 \text{ V}$ , $I_{OUT} = 0 \text{ mA} \rightarrow 150 \text{ mA}$	—	50	150	mV
Peak output current *2	$I_{PEAK}$	$V_{IN} = 4.3 \text{ V}$ , The output current value decreases by 5% from the value when $V_{OUT}$ is at $I_{OUT} = 50 \text{ mA}$ .	180	240	—	mA
Bias current without load	$I_{BIAS}$	$V_{IN} = 4.3 \text{ V}$ , $I_{OUT} = 0 \text{ mA}$	—	—	350	$\mu\text{A}$
Bias current fluctuation with load	$\Delta I_{BIAS}$	$V_{IN} = 4.3 \text{ V}$ , $I_{OUT} = 0 \text{ mA} \rightarrow 150 \text{ mA}$	—	—	5	mA
Standby consumption current	$I_{STB}$	$V_{IN} = 10 \text{ V}$ , $V_{CONT} = 0 \text{ V}$	—	—	0.1	$\mu\text{A}$
Bias current before starting regulation	$I_{RUSH}$	$V_{IN} = 3.0 \text{ V}$ , $I_{OUT} = 0 \text{ mA}$	—	1.5	5	mA
Ripple rejection ratio	R.R.	$1 \text{ V}_{\text{rms}}$ , $f = 120 \text{ Hz}$ , $I_{OUT} = 10 \text{ mA}$	59	67	—	dB
Minimum input and output voltage difference 1	$V_{DIF(\text{min})1}$	$V_{IN} = 3.0 \text{ V}$ , $I_{OUT} = 0 \text{ mA}$	—	0.1	0.2	V
Minimum input and output voltage difference 2	$V_{DIF(\text{min})2}$	$V_{IN} = 3.4 \text{ V}$ , $I_{OUT} = 150 \text{ mA}$	—	—	0.4	V
Control terminal threshold high voltage	$V_{CONTH}$	$V_{IN} = 4.3 \text{ V}$ , $I_{OUT} = 50 \text{ mA}$	—	—	1.50	V
Control terminal threshold high voltage	$V_{CONTH}$	$V_{IN} = 4.3 \text{ V}$ , $I_{OUT} = 50 \text{ mA}$	0.30	—	—	V
Control terminal current	$I_{CONT}$	$V_{IN} = 4.3 \text{ V}$ , $I_{OUT} = 50 \text{ mA}$ $V_{CONT} = 1.8 \text{ V}$	—	—	30	$\mu\text{A}$

Note) \*1 :  $1.0 \Omega$

\*2 : Peak output current : The output current when the output voltage has been decreased by 5% from the value at the time of the output current is 50 mA due to the overcurrent protection.

## • Design reference data

Note) The following values are typical and not guaranteed values.

Parameter	Symbol	Conditions	Min	Typ	Max	Unit
Output noise voltage	$V_{NO}$	$10\text{Hz} \leq f \leq 100\text{kHz}$ , $I_{OUT} = 10 \text{ mA}$	—	68	—	$\mu\text{V}$
Output voltage temperature coefficient	$\frac{1}{V_{OUT}} \cdot \frac{dV_{OUT}}{dT}$	$V_{IN} = 4.3 \text{ V}$ , $I_{OUT} = 0 \text{ mA}$ $-30^\circ\text{C} \leq T_a \leq +85^\circ\text{C}$	—	90	—	ppm/ $^\circ\text{C}$
Output rise time	$t_{ON}$	$V_{IN} = 4.3 \text{ V}$ , $I_{OUT} = 50 \text{ mA}$ $V_{CONT} = 0 \text{ V} \rightarrow 1.8 \text{ V}$ , $C_{IN} = 0.1 \mu\text{F}$ $C_{OUT} = 10 \mu\text{F}$ , $V_{OUT} = 90\%$	—	0.12	—	ms

Note) \*1 : Refer to ■ Technical Information " • Output rise time characteristics".

## AN80L34RMS (3.4 V)

## ■ Recommended Operating Range

Parameter	Symbol	Range	Unit
Supply voltage	$V_{CC}$	3.8 to 14.5	V

■ Electrical Characteristics at  $T_a = 25^\circ\text{C}$ 

Note) Unless otherwise specially provided, shorten each test time (within 10 ms) so that the test is conducted under the condition that the drift due to the temperature increase in the chip junction part can be neglected.  $C_{IN} = 0.1 \mu\text{F}$ ,  $C_{OUT} = 10 \mu\text{F}$

Parameter	Symbol	Conditions	Min	Typ	Max	Unit
Output voltage	$V_{OUT}$	$V_{IN} = 4.4 \text{ V}$ , $I_{OUT} = 50 \text{ mA}$	3.298	3.4	3.502	V
Input stability 1	$REG_{IN1}$	$V_{IN} = 4.4 \text{ V} \rightarrow 14.5 \text{ V}$ , $I_{OUT} = 50 \text{ mA}$	—	10	50	mV
Input stability 2	$REG_{IN2}$	$V_{IN} = 4.4 \text{ V} \rightarrow 9 \text{ V}$ , $I_{OUT} = 50 \text{ mA}$	—	5	20	mV
Load stability *1	$REG_{LOA}$	$V_{IN} = 4.4 \text{ V}$ , $I_{OUT} = 0 \text{ mA} \rightarrow 150 \text{ mA}$	—	50	150	mV
Peak output current *2	$I_{PEAK}$	$V_{IN} = 4.4 \text{ V}$ , The output current value decreases by 5% from the value when $V_{OUT}$ is at $I_{OUT} = 50 \text{ mA}$ .	180	240	—	mA
Bias current without load	$I_{BIAS}$	$V_{IN} = 4.4 \text{ V}$ , $I_{OUT} = 0 \text{ mA}$	—	—	350	$\mu\text{A}$
Bias current fluctuation with load	$\Delta I_{BIAS}$	$V_{IN} = 4.4 \text{ V}$ , $I_{OUT} = 0 \text{ mA} \rightarrow 150 \text{ mA}$	—	—	5	mA
Standby consumption current	$I_{STB}$	$V_{IN} = 10 \text{ V}$ , $V_{CONT} = 0 \text{ V}$	—	—	0.1	$\mu\text{A}$
Bias current before starting regulation	$I_{RUSH}$	$V_{IN} = 3.1 \text{ V}$ , $I_{OUT} = 0 \text{ mA}$	—	1.5	5	mA
Ripple rejection ratio	R.R.	$1 \text{ V}_{\text{rms}}$ , $f = 120 \text{ Hz}$ , $I_{OUT} = 10 \text{ mA}$	58	66	—	dB
Minimum input and output voltage difference 1	$V_{DIF(\text{min})1}$	$V_{IN} = 3.1 \text{ V}$ , $I_{OUT} = 0 \text{ mA}$	—	0.1	0.2	V
Minimum input and output voltage difference 2	$V_{DIF(\text{min})2}$	$V_{IN} = 3.5 \text{ V}$ , $I_{OUT} = 150 \text{ mA}$	—	—	0.4	V
Control terminal threshold high voltage	$V_{CONTH}$	$V_{IN} = 4.4 \text{ V}$ , $I_{OUT} = 50 \text{ mA}$	—	—	1.50	V
Control terminal threshold high voltage	$V_{CONTH}$	$V_{IN} = 4.4 \text{ V}$ , $I_{OUT} = 50 \text{ mA}$	0.30	—	—	V
Control terminal current	$I_{CONT}$	$V_{IN} = 4.4 \text{ V}$ , $I_{OUT} = 50 \text{ mA}$ $V_{CONT} = 1.8 \text{ V}$	—	—	30	$\mu\text{A}$

Note) \*1 :  $1.0 \Omega$

\*2 : Peak output current : The output current when the output voltage has been decreased by 5% from the value at the time of the output current is 50 mA due to the overcurrent protection.

## • Design reference data

Note) The following values are typical and not guaranteed values.

Parameter	Symbol	Conditions	Min	Typ	Max	Unit
Output noise voltage	$V_{NO}$	$10\text{Hz} \leq f \leq 100\text{kHz}$ , $I_{OUT} = 10 \text{ mA}$	—	70	—	$\mu\text{V}$
Output voltage temperature coefficient	$\frac{1}{V_{OUT}} \cdot \frac{dV_{OUT}}{dT}$	$V_{IN} = 4.4 \text{ V}$ , $I_{OUT} = 0 \text{ mA}$ $-30^\circ\text{C} \leq T_a \leq +85^\circ\text{C}$	—	90	—	ppm/ $^\circ\text{C}$
Output rise time	$t_{ON}$	$V_{IN} = 4.4 \text{ V}$ , $I_{OUT} = 50 \text{ mA}$ $V_{CONT} = 0 \text{ V} \rightarrow 1.8 \text{ V}$ , $C_{IN} = 0.1 \mu\text{F}$ $C_{OUT} = 10 \mu\text{F}$ , $V_{OUT} = 90\%$	—	0.12	—	ms

Note) \*1 : Refer to ■ Technical Information " • Output rise time characteristics".

## AN80L35RMS (3.5 V)

## ■ Recommended Operating Range

Parameter	Symbol	Range	Unit
Supply voltage	$V_{CC}$	3.9 to 14.5	V

■ Electrical Characteristics at  $T_a = 25^\circ\text{C}$ 

Note) Unless otherwise specially provided, shorten each test time (within 10 ms) so that the test is conducted under the condition that the drift due to the temperature increase in the chip junction part can be neglected.  $C_{IN} = 0.1 \mu\text{F}$ ,  $C_{OUT} = 10 \mu\text{F}$

Parameter	Symbol	Conditions	Min	Typ	Max	Unit
Output voltage	$V_{OUT}$	$V_{IN} = 4.5 \text{ V}$ , $I_{OUT} = 50 \text{ mA}$	3.395	3.5	3.605	V
Input stability 1	$REG_{IN1}$	$V_{IN} = 4.5 \text{ V} \rightarrow 14.5 \text{ V}$ , $I_{OUT} = 50 \text{ mA}$	—	10	50	mV
Input stability 2	$REG_{IN2}$	$V_{IN} = 4.5 \text{ V} \rightarrow 9 \text{ V}$ , $I_{OUT} = 50 \text{ mA}$	—	5	20	mV
Load stability *1	$REG_{LOA}$	$V_{IN} = 4.5 \text{ V}$ , $I_{OUT} = 0 \text{ mA} \rightarrow 150 \text{ mA}$	—	50	150	mV
Peak output current *2	$I_{PEAK}$	$V_{IN} = 4.5 \text{ V}$ , The output current value decreases by 5% from the value when $V_{OUT}$ is at $I_{OUT} = 50 \text{ mA}$ .	180	240	—	mA
Bias current without load	$I_{BIAS}$	$V_{IN} = 4.5 \text{ V}$ , $I_{OUT} = 0 \text{ mA}$	—	—	350	$\mu\text{A}$
Bias current fluctuation with load	$\Delta I_{BIAS}$	$V_{IN} = 4.5 \text{ V}$ , $I_{OUT} = 0 \text{ mA} \rightarrow 150 \text{ mA}$	—	—	5	mA
Standby consumption current	$I_{STB}$	$V_{IN} = 10 \text{ V}$ , $V_{CONT} = 0 \text{ V}$	—	—	0.1	$\mu\text{A}$
Bias current before starting regulation	$I_{RUSH}$	$V_{IN} = 3.2 \text{ V}$ , $I_{OUT} = 0 \text{ mA}$	—	1.5	5	mA
Ripple rejection ratio	R.R.	$1 \text{ V}_{\text{rms}}$ , $f = 120 \text{ Hz}$ , $I_{OUT} = 10 \text{ mA}$	58	66	—	dB
Minimum input and output voltage difference 1	$V_{DIF(\text{min})1}$	$V_{IN} = 3.2 \text{ V}$ , $I_{OUT} = 0 \text{ mA}$	—	0.1	0.2	V
Minimum input and output voltage difference 2	$V_{DIF(\text{min})2}$	$V_{IN} = 3.6 \text{ V}$ , $I_{OUT} = 150 \text{ mA}$	—	—	0.4	V
Control terminal threshold high voltage	$V_{CONTH}$	$V_{IN} = 4.5 \text{ V}$ , $I_{OUT} = 50 \text{ mA}$	—	—	1.50	V
Control terminal threshold high voltage	$V_{CONTH}$	$V_{IN} = 4.5 \text{ V}$ , $I_{OUT} = 50 \text{ mA}$	0.30	—	—	V
Control terminal current	$I_{CONT}$	$V_{IN} = 4.5 \text{ V}$ , $I_{OUT} = 50 \text{ mA}$ $V_{CONT} = 1.8 \text{ V}$	—	—	30	$\mu\text{A}$

Note) \*1 :  $1.0 \Omega$

\*2 : Peak output current : The output current when the output voltage has been decreased by 5% from the value at the time of the output current is 50 mA due to the overcurrent protection.

## • Design reference data

Note) The following values are typical and not guaranteed values.

Parameter	Symbol	Conditions	Min	Typ	Max	Unit
Output noise voltage	$V_{NO}$	$10\text{Hz} \leq f \leq 100\text{kHz}$ , $I_{OUT} = 10 \text{ mA}$	—	72	—	$\mu\text{V}$
Output voltage temperature coefficient	$\frac{1}{V_{OUT}} \cdot \frac{dV_{OUT}}{dT}$	$V_{IN} = 4.5 \text{ V}$ , $I_{OUT} = 0 \text{ mA}$ $-30^\circ\text{C} \leq T_a \leq +85^\circ\text{C}$	—	90	—	ppm/ $^\circ\text{C}$
Output rise time	$t_{ON}$	$V_{IN} = 4.5 \text{ V}$ , $I_{OUT} = 50 \text{ mA}$ $V_{CONT} = 0 \text{ V} \rightarrow 1.8 \text{ V}$ , $C_{IN} = 0.1 \mu\text{F}$ $C_{OUT} = 10 \mu\text{F}$ , $V_{OUT} = 90\%$	—	0.12	—	ms

Note) \*1 : Refer to ■ Technical Information " • Output rise time characteristics".

## AN80L36RMS (3.6 V)

## ■ Recommended Operating Range

Parameter	Symbol	Range	Unit
Supply voltage	$V_{CC}$	4.0 to 14.5	V

■ Electrical Characteristics at  $T_a = 25^\circ\text{C}$ 

Note) Unless otherwise specially provided, shorten each test time (within 10 ms) so that the test is conducted under the condition that the drift due to the temperature increase in the chip junction part can be neglected.  $C_{IN} = 0.1 \mu\text{F}$ ,  $C_{OUT} = 10 \mu\text{F}$

Parameter	Symbol	Conditions	Min	Typ	Max	Unit
Output voltage	$V_{OUT}$	$V_{IN} = 4.6 \text{ V}$ , $I_{OUT} = 50 \text{ mA}$	3.492	3.6	3.708	V
Input stability 1	$REG_{IN1}$	$V_{IN} = 4.6 \text{ V} \rightarrow 14.5 \text{ V}$ , $I_{OUT} = 50 \text{ mA}$	—	10	50	mV
Input stability 2	$REG_{IN2}$	$V_{IN} = 4.6 \text{ V} \rightarrow 9 \text{ V}$ , $I_{OUT} = 50 \text{ mA}$	—	5	20	mV
Load stability *1	$REG_{LOA}$	$V_{IN} = 4.6 \text{ V}$ , $I_{OUT} = 0 \text{ mA} \rightarrow 150 \text{ mA}$	—	50	150	mV
Peak output current *2	$I_{PEAK}$	$V_{IN} = 4.6 \text{ V}$ , The output current value decreases by 5% from the value when $V_{OUT}$ is at $I_{OUT} = 50 \text{ mA}$ .	180	240	—	mA
Bias current without load	$I_{BIAS}$	$V_{IN} = 4.6 \text{ V}$ , $I_{OUT} = 0 \text{ mA}$	—	—	350	$\mu\text{A}$
Bias current fluctuation with load	$\Delta I_{BIAS}$	$V_{IN} = 4.6 \text{ V}$ , $I_{OUT} = 0 \text{ mA} \rightarrow 150 \text{ mA}$	—	—	5	mA
Standby consumption current	$I_{STB}$	$V_{IN} = 10 \text{ V}$ , $V_{CONT} = 0 \text{ V}$	—	—	0.1	$\mu\text{A}$
Bias current before starting regulation	$I_{RUSH}$	$V_{IN} = 3.3 \text{ V}$ , $I_{OUT} = 0 \text{ mA}$	—	1.5	5	mA
Ripple rejection ratio	R.R.	$1 \text{ V}_{\text{rms}}$ , $f = 120 \text{ Hz}$ , $I_{OUT} = 10 \text{ mA}$	58	66	—	dB
Minimum input and output voltage difference 1	$V_{DIF(\text{min})1}$	$V_{IN} = 3.3 \text{ V}$ , $I_{OUT} = 0 \text{ mA}$	—	0.1	0.2	V
Minimum input and output voltage difference 2	$V_{DIF(\text{min})2}$	$V_{IN} = 3.7 \text{ V}$ , $I_{OUT} = 150 \text{ mA}$	—	—	0.4	V
Control terminal threshold high voltage	$V_{CONTH}$	$V_{IN} = 4.6 \text{ V}$ , $I_{OUT} = 50 \text{ mA}$	—	—	1.50	V
Control terminal threshold high voltage	$V_{CONTH}$	$V_{IN} = 4.6 \text{ V}$ , $I_{OUT} = 50 \text{ mA}$	0.30	—	—	V
Control terminal current	$I_{CONT}$	$V_{IN} = 4.6 \text{ V}$ , $I_{OUT} = 50 \text{ mA}$ $V_{CONT} = 1.8 \text{ V}$	—	—	30	$\mu\text{A}$

Note) \*1 :  $1.0 \Omega$

\*2 : Peak output current : The output current when the output voltage has been decreased by 5% from the value at the time of the output current is 50 mA due to the overcurrent protection.

## • Design reference data

Note) The following values are typical and not guaranteed values.

Parameter	Symbol	Conditions	Min	Typ	Max	Unit
Output noise voltage	$V_{NO}$	$10\text{Hz} \leq f \leq 100\text{kHz}$ , $I_{OUT} = 10 \text{ mA}$	—	74	—	$\mu\text{V}$
Output voltage temperature coefficient	$\frac{1}{V_{OUT}} \cdot \frac{dV_{OUT}}{dT}$	$V_{IN} = 4.6 \text{ V}$ , $I_{OUT} = 0 \text{ mA}$ $-30^\circ\text{C} \leq T_a \leq +85^\circ\text{C}$	—	90	—	ppm/ $^\circ\text{C}$
Output rise time	$t_{ON}$	$V_{IN} = 4.6 \text{ V}$ , $I_{OUT} = 50 \text{ mA}$ $V_{CONT} = 0 \text{ V} \rightarrow 1.8 \text{ V}$ , $C_{IN} = 0.1 \mu\text{F}$ $C_{OUT} = 10 \mu\text{F}$ , $V_{OUT} = 90\%$	—	0.12	—	ms

Note) \*1 : Refer to ■ Technical Information " • Output rise time characteristics".

## AN80L48RMS (4.8 V)

## ■ Recommended Operating Range

Parameter	Symbol	Range	Unit
Supply voltage	$V_{CC}$	5.2 to 14.5	V

■ Electrical Characteristics at  $T_a = 25^\circ\text{C}$ 

Note) Unless otherwise specially provided, shorten each test time (within 10 ms) so that the test is conducted under the condition that the drift due to the temperature increase in the chip junction part can be neglected.  $C_{IN} = 0.1 \mu\text{F}$ ,  $C_{OUT} = 10 \mu\text{F}$

Parameter	Symbol	Conditions	Min	Typ	Max	Unit
Output voltage	$V_{OUT}$	$V_{IN} = 5.8 \text{ V}$ , $I_{OUT} = 50 \text{ mA}$	4.656	4.8	4.944	V
Input stability 1	$REG_{IN1}$	$V_{IN} = 5.8 \text{ V} \rightarrow 14.5 \text{ V}$ , $I_{OUT} = 50 \text{ mA}$	—	10	50	mV
Input stability 2	$REG_{IN2}$	$V_{IN} = 5.8 \text{ V} \rightarrow 9 \text{ V}$ , $I_{OUT} = 50 \text{ mA}$	—	5	20	mV
Load stability *1	$REG_{LOA}$	$V_{IN} = 5.8 \text{ V}$ , $I_{OUT} = 0 \text{ mA} \rightarrow 150 \text{ mA}$	—	50	150	mV
Peak output current *2	$I_{PEAK}$	$V_{IN} = 5.8 \text{ V}$ , The output current value decreases by 5% from the value when $V_{OUT}$ is at $I_{OUT} = 50 \text{ mA}$ .	180	240	—	mA
Bias current without load	$I_{BIAS}$	$V_{IN} = 5.8 \text{ V}$ , $I_{OUT} = 0 \text{ mA}$	—	—	350	$\mu\text{A}$
Bias current fluctuation with load	$\Delta I_{BIAS}$	$V_{IN} = 5.8 \text{ V}$ , $I_{OUT} = 0 \text{ mA} \rightarrow 150 \text{ mA}$	—	—	5	mA
Standby consumption current	$I_{STB}$	$V_{IN} = 10 \text{ V}$ , $V_{CONT} = 0 \text{ V}$	—	—	0.1	$\mu\text{A}$
Bias current before starting regulation	$I_{RUSH}$	$V_{IN} = 4.5 \text{ V}$ , $I_{OUT} = 0 \text{ mA}$	—	1.5	5	mA
Ripple rejection ratio	R.R.	$1 \text{ V}_{\text{rms}}$ , $f = 120 \text{ Hz}$ , $I_{OUT} = 10 \text{ mA}$	57	65	—	dB
Minimum input and output voltage difference 1	$V_{DIF(\text{min})1}$	$V_{IN} = 4.5 \text{ V}$ , $I_{OUT} = 0 \text{ mA}$	—	0.1	0.2	V
Minimum input and output voltage difference 2	$V_{DIF(\text{min})2}$	$V_{IN} = 4.9 \text{ V}$ , $I_{OUT} = 150 \text{ mA}$	—	—	0.4	V
Control terminal threshold high voltage	$V_{CONTH}$	$V_{IN} = 5.8 \text{ V}$ , $I_{OUT} = 50 \text{ mA}$	—	—	1.50	V
Control terminal threshold high voltage	$V_{CONTH}$	$V_{IN} = 5.8 \text{ V}$ , $I_{OUT} = 50 \text{ mA}$	0.30	—	—	V
Control terminal current	$I_{CONT}$	$V_{IN} = 5.8 \text{ V}$ , $I_{OUT} = 50 \text{ mA}$ $V_{CONT} = 1.8 \text{ V}$	—	—	30	$\mu\text{A}$

Note) \*1 :  $1.0 \Omega$

\*2 : Peak output current : The output current when the output voltage has been decreased by 5% from the value at the time of the output current is 50 mA due to the overcurrent protection.

## • Design reference data

Note) The following values are typical and not guaranteed values.

Parameter	Symbol	Conditions	Min	Typ	Max	Unit
Output noise voltage	$V_{NO}$	$10\text{Hz} \leq f \leq 100\text{kHz}$ , $I_{OUT} = 10 \text{ mA}$	—	100	—	$\mu\text{V}$
Output voltage temperature coefficient	$\frac{1}{V_{OUT}} \cdot \frac{dV_{OUT}}{dT}$	$V_{IN} = 5.8 \text{ V}$ , $I_{OUT} = 0 \text{ mA}$ $-30^\circ\text{C} \leq T_a \leq +85^\circ\text{C}$	—	90	—	ppm/ $^\circ\text{C}$
Output rise time	$t_{ON}$	$V_{IN} = 5.8 \text{ V}$ , $I_{OUT} = 50 \text{ mA}$ $V_{CONT} = 0 \text{ V} \rightarrow 1.8 \text{ V}$ , $C_{IN} = 0.1 \mu\text{F}$ $C_{OUT} = 10 \mu\text{F}$ , $V_{OUT} = 90\%$	—	0.20	—	ms

Note) \*1 : Refer to ■ Technical Information " • Output rise time characteristics".

## AN80L49RMS (4.9 V)

## ■ Recommended Operating Range

Parameter	Symbol	Range	Unit
Supply voltage	$V_{CC}$	5.3 to 14.5	V

■ Electrical Characteristics at  $T_a = 25^\circ\text{C}$ 

Note) Unless otherwise specially provided, shorten each test time (within 10 ms) so that the test is conducted under the condition that the drift due to the temperature increase in the chip junction part can be neglected.  $C_{IN} = 0.1 \mu\text{F}$ ,  $C_{OUT} = 10 \mu\text{F}$

Parameter	Symbol	Conditions	Min	Typ	Max	Unit
Output voltage	$V_{OUT}$	$V_{IN} = 5.9 \text{ V}$ , $I_{OUT} = 50 \text{ mA}$	4.753	4.9	5.047	V
Input stability 1	$REG_{IN1}$	$V_{IN} = 5.9 \text{ V} \rightarrow 14.5 \text{ V}$ , $I_{OUT} = 50 \text{ mA}$	—	10	50	mV
Input stability 2	$REG_{IN2}$	$V_{IN} = 5.9 \text{ V} \rightarrow 9 \text{ V}$ , $I_{OUT} = 50 \text{ mA}$	—	5	20	mV
Load stability *1	$REG_{LOA}$	$V_{IN} = 5.9 \text{ V}$ , $I_{OUT} = 0 \text{ mA} \rightarrow 150 \text{ mA}$	—	50	150	mV
Peak output current *2	$I_{PEAK}$	$V_{IN} = 5.9 \text{ V}$ , The output current value decreases by 5% from the value when $V_{OUT}$ is at $I_{OUT} = 50 \text{ mA}$ .	180	240	—	mA
Bias current without load	$I_{BIAS}$	$V_{IN} = 5.9 \text{ V}$ , $I_{OUT} = 0 \text{ mA}$	—	—	350	$\mu\text{A}$
Bias current fluctuation with load	$\Delta I_{BIAS}$	$V_{IN} = 5.9 \text{ V}$ , $I_{OUT} = 0 \text{ mA} \rightarrow 150 \text{ mA}$	—	—	5	mA
Standby consumption current	$I_{STB}$	$V_{IN} = 10 \text{ V}$ , $V_{CONT} = 0 \text{ V}$	—	—	0.1	$\mu\text{A}$
Bias current before starting regulation	$I_{RUSH}$	$V_{IN} = 4.6 \text{ V}$ , $I_{OUT} = 0 \text{ mA}$	—	1.5	5	mA
Ripple rejection ratio	R.R.	$1 \text{ V}_{\text{rms}}$ , $f = 120 \text{ Hz}$ , $I_{OUT} = 10 \text{ mA}$	57	65	—	dB
Minimum input and output voltage difference 1	$V_{DIF(\text{min})1}$	$V_{IN} = 4.6 \text{ V}$ , $I_{OUT} = 0 \text{ mA}$	—	0.1	0.2	V
Minimum input and output voltage difference 2	$V_{DIF(\text{min})2}$	$V_{IN} = 5.0 \text{ V}$ , $I_{OUT} = 150 \text{ mA}$	—	—	0.4	V
Control terminal threshold high voltage	$V_{CONTH}$	$V_{IN} = 5.9 \text{ V}$ , $I_{OUT} = 50 \text{ mA}$	—	—	1.50	V
Control terminal threshold high voltage	$V_{CONTH}$	$V_{IN} = 5.9 \text{ V}$ , $I_{OUT} = 50 \text{ mA}$	0.30	—	—	V
Control terminal current	$I_{CONT}$	$V_{IN} = 5.9 \text{ V}$ , $I_{OUT} = 50 \text{ mA}$ $V_{CONT} = 1.8 \text{ V}$	—	—	30	$\mu\text{A}$

Note) \*1 :  $1.0 \Omega$

\*2 : Peak output current : The output current when the output voltage has been decreased by 5% from the value at the time of the output current is 50 mA due to the overcurrent protection.

## • Design reference data

Note) The following values are typical and not guaranteed values.

Parameter	Symbol	Conditions	Min	Typ	Max	Unit
Output noise voltage	$V_{NO}$	$10\text{Hz} \leq f \leq 100\text{kHz}$ , $I_{OUT} = 10 \text{ mA}$	—	102	—	$\mu\text{V}$
Output voltage temperature coefficient	$\frac{1}{V_{OUT}} \cdot \frac{dV_{OUT}}{dT}$	$V_{IN} = 5.9 \text{ V}$ , $I_{OUT} = 0 \text{ mA}$ $-30^\circ\text{C} \leq T_a \leq +85^\circ\text{C}$	—	90	—	ppm/ $^\circ\text{C}$
Output rise time	$t_{ON}$	$V_{IN} = 5.9 \text{ V}$ , $I_{OUT} = 50 \text{ mA}$ $V_{CONT} = 0 \text{ V} \rightarrow 1.8 \text{ V}$ , $C_{IN} = 0.1 \mu\text{F}$ $C_{OUT} = 10 \mu\text{F}$ , $V_{OUT} = 90\%$	—	0.20	—	ms

Note) \*1 : Refer to ■ Technical Information " • Output rise time characteristics".

## AN80L50RMS (5.0 V)

## ■ Recommended Operating Range

Parameter	Symbol	Range	Unit
Supply voltage	$V_{CC}$	5.4 to 14.5	V

■ Electrical Characteristics at  $T_a = 25^\circ\text{C}$ 

Note) Unless otherwise specially provided, shorten each test time (within 10 ms) so that the test is conducted under the condition that the drift due to the temperature increase in the chip junction part can be neglected.  $C_{IN} = 0.1 \mu\text{F}$ ,  $C_{OUT} = 10 \mu\text{F}$

Parameter	Symbol	Conditions	Min	Typ	Max	Unit
Output voltage	$V_{OUT}$	$V_{IN} = 6.0 \text{ V}$ , $I_{OUT} = 50 \text{ mA}$	4.850	5.0	5.150	V
Input stability 1	$REG_{IN1}$	$V_{IN} = 6.0 \text{ V} \rightarrow 14.5 \text{ V}$ , $I_{OUT} = 50 \text{ mA}$	—	10	50	mV
Input stability 2	$REG_{IN2}$	$V_{IN} = 6.0 \text{ V} \rightarrow 9 \text{ V}$ , $I_{OUT} = 50 \text{ mA}$	—	5	20	mV
Load stability *1	$REG_{LOA}$	$V_{IN} = 6.0 \text{ V}$ , $I_{OUT} = 0 \text{ mA} \rightarrow 150 \text{ mA}$	—	50	150	mV
Peak output current *2	$I_{PEAK}$	$V_{IN} = 6.0 \text{ V}$ , The output current value decreases by 5% from the value when $V_{OUT}$ is at $I_{OUT} = 50 \text{ mA}$ .	180	240	—	mA
Bias current without load	$I_{BIAS}$	$V_{IN} = 6.0 \text{ V}$ , $I_{OUT} = 0 \text{ mA}$	—	—	350	$\mu\text{A}$
Bias current fluctuation with load	$\Delta I_{BIAS}$	$V_{IN} = 6.0 \text{ V}$ , $I_{OUT} = 0 \text{ mA} \rightarrow 150 \text{ mA}$	—	—	5	mA
Standby consumption current	$I_{STB}$	$V_{IN} = 10 \text{ V}$ , $V_{CONT} = 0 \text{ V}$	—	—	0.1	$\mu\text{A}$
Bias current before starting regulation	$I_{RUSH}$	$V_{IN} = 4.7 \text{ V}$ , $I_{OUT} = 0 \text{ mA}$	—	1.5	5	mA
Ripple rejection ratio	R.R.	$1 \text{ V}_{\text{rms}}$ , $f = 120 \text{ Hz}$ , $I_{OUT} = 10 \text{ mA}$	56	64	—	dB
Minimum input and output voltage difference 1	$V_{DIF(\text{min})1}$	$V_{IN} = 4.7 \text{ V}$ , $I_{OUT} = 0 \text{ mA}$	—	0.1	0.2	V
Minimum input and output voltage difference 2	$V_{DIF(\text{min})2}$	$V_{IN} = 5.1 \text{ V}$ , $I_{OUT} = 150 \text{ mA}$	—	—	0.4	V
Control terminal threshold high voltage	$V_{CONTH}$	$V_{IN} = 6.0 \text{ V}$ , $I_{OUT} = 50 \text{ mA}$	—	—	1.50	V
Control terminal threshold high voltage	$V_{CONTH}$	$V_{IN} = 6.0 \text{ V}$ , $I_{OUT} = 50 \text{ mA}$	0.30	—	—	V
Control terminal current	$I_{CONT}$	$V_{IN} = 6.0 \text{ V}$ , $I_{OUT} = 50 \text{ mA}$ $V_{CONT} = 1.8 \text{ V}$	—	—	30	$\mu\text{A}$

Note) \*1 :  $1.0 \Omega$

\*2 : Peak output current : The output current when the output voltage has been decreased by 5% from the value at the time of the output current is 50 mA due to the overcurrent protection.

## • Design reference data

Note) The following values are typical and not guaranteed values.

Parameter	Symbol	Conditions	Min	Typ	Max	Unit
Output noise voltage	$V_{NO}$	$10\text{Hz} \leq f \leq 100\text{kHz}$ , $I_{OUT} = 10 \text{ mA}$	—	104	—	$\mu\text{V}$
Output voltage temperature coefficient	$\frac{1}{V_{OUT}} \cdot \frac{dV_{OUT}}{dT}$	$V_{IN} = 6.0 \text{ V}$ , $I_{OUT} = 0 \text{ mA}$ $-30^\circ\text{C} \leq T_a \leq +85^\circ\text{C}$	—	90	—	ppm/ $^\circ\text{C}$
Output rise time	$t_{ON}$	$V_{IN} = 6.0 \text{ V}$ , $I_{OUT} = 50 \text{ mA}$ $V_{CONT} = 0 \text{ V} \rightarrow 1.8 \text{ V}$ , $C_{IN} = 0.1 \mu\text{F}$ $C_{OUT} = 10 \mu\text{F}$ , $V_{OUT} = 90\%$	—	0.20	—	ms

Note) \*1 : Refer to ■ Technical Information " • Output rise time characteristics".

## AN80L51RMS (5.1 V)

## ■ Recommended Operating Range

Parameter	Symbol	Range	Unit
Supply voltage	$V_{CC}$	5.5 to 14.5	V

■ Electrical Characteristics at  $T_a = 25^\circ\text{C}$ 

Note) Unless otherwise specially provided, shorten each test time (within 10 ms) so that the test is conducted under the condition that the drift due to the temperature increase in the chip junction part can be neglected.  $C_{IN} = 0.1 \mu\text{F}$ ,  $C_{OUT} = 10 \mu\text{F}$

Parameter	Symbol	Conditions	Min	Typ	Max	Unit
Output voltage	$V_{OUT}$	$V_{IN} = 6.1 \text{ V}$ , $I_{OUT} = 50 \text{ mA}$	4.947	5.1	5.253	V
Input stability 1	$REG_{IN1}$	$V_{IN} = 6.1 \text{ V} \rightarrow 14.5 \text{ V}$ , $I_{OUT} = 50 \text{ mA}$	—	10	50	mV
Input stability 2	$REG_{IN2}$	$V_{IN} = 6.1 \text{ V} \rightarrow 9 \text{ V}$ , $I_{OUT} = 50 \text{ mA}$	—	5	20	mV
Load stability *1	$REG_{LOA}$	$V_{IN} = 6.1 \text{ V}$ , $I_{OUT} = 0 \text{ mA} \rightarrow 150 \text{ mA}$	—	50	150	mV
Peak output current *2	$I_{PEAK}$	$V_{IN} = 6.1 \text{ V}$ , The output current value decreases by 5% from the value when $V_{OUT}$ is at $I_{OUT} = 50 \text{ mA}$ .	180	240	—	mA
Bias current without load	$I_{BIAS}$	$V_{IN} = 6.1 \text{ V}$ , $I_{OUT} = 0 \text{ mA}$	—	—	350	$\mu\text{A}$
Bias current fluctuation with load	$\Delta I_{BIAS}$	$V_{IN} = 6.1 \text{ V}$ , $I_{OUT} = 0 \text{ mA} \rightarrow 150 \text{ mA}$	—	—	5	mA
Standby consumption current	$I_{STB}$	$V_{IN} = 10 \text{ V}$ , $V_{CONT} = 0 \text{ V}$	—	—	0.1	$\mu\text{A}$
Bias current before starting regulation	$I_{RUSH}$	$V_{IN} = 4.8 \text{ V}$ , $I_{OUT} = 0 \text{ mA}$	—	1.5	5	mA
Ripple rejection ratio	R.R.	$1 \text{ V}_{\text{rms}}$ , $f = 120 \text{ Hz}$ , $I_{OUT} = 10 \text{ mA}$	56	64	—	dB
Minimum input and output voltage difference 1	$V_{DIF(\text{min})1}$	$V_{IN} = 4.8 \text{ V}$ , $I_{OUT} = 0 \text{ mA}$	—	0.1	0.2	V
Minimum input and output voltage difference 2	$V_{DIF(\text{min})2}$	$V_{IN} = 5.2 \text{ V}$ , $I_{OUT} = 150 \text{ mA}$	—	—	0.4	V
Control terminal threshold high voltage	$V_{CONTH}$	$V_{IN} = 6.1 \text{ V}$ , $I_{OUT} = 50 \text{ mA}$	—	—	1.50	V
Control terminal threshold high voltage	$V_{CONTH}$	$V_{IN} = 6.1 \text{ V}$ , $I_{OUT} = 50 \text{ mA}$	0.30	—	—	V
Control terminal current	$I_{CONT}$	$V_{IN} = 6.1 \text{ V}$ , $I_{OUT} = 50 \text{ mA}$ $V_{CONT} = 1.8 \text{ V}$	—	—	30	$\mu\text{A}$

Note) \*1 :  $1.0 \Omega$

\*2 : Peak output current : The output current when the output voltage has been decreased by 5% from the value at the time of the output current is 50 mA due to the overcurrent protection.

## • Design reference data

Note) The following values are typical and not guaranteed values.

Parameter	Symbol	Conditions	Min	Typ	Max	Unit
Output noise voltage	$V_{NO}$	$10\text{Hz} \leq f \leq 100\text{kHz}$ , $I_{OUT} = 10 \text{ mA}$	—	106	—	$\mu\text{V}$
Output voltage temperature coefficient	$\frac{1}{V_{OUT}} \cdot \frac{dV_{OUT}}{dT}$	$V_{IN} = 6.1 \text{ V}$ , $I_{OUT} = 0 \text{ mA}$ $-30^\circ\text{C} \leq T_a \leq +85^\circ\text{C}$	—	90	—	ppm/ $^\circ\text{C}$
Output rise time	$t_{ON}$	$V_{IN} = 6.1 \text{ panpa V}$ , $I_{OUT} = 50 \text{ mA}$ $V_{CONT} = 0 \text{ V} \rightarrow 1.8 \text{ V}$ , $C_{IN} = 0.1 \mu\text{F}$ $C_{OUT} = 10 \mu\text{F}$ , $V_{OUT} = 90\%$	—	0.20	—	ms

Note) \*1 : Refer to ■ Technical Information " • Output rise time characteristics".

## AN80L52RMS (5.2 V)

## ■ Recommended Operating Range

Parameter	Symbol	Range	Unit
Supply voltage	$V_{CC}$	5.6 to 14.5	V

■ Electrical Characteristics at  $T_a = 25^\circ\text{C}$ 

Note) Unless otherwise specially provided, shorten each test time (within 10 ms) so that the test is conducted under the condition that the drift due to the temperature increase in the chip junction part can be neglected.  $C_{IN} = 0.1 \mu\text{F}$ ,  $C_{OUT} = 10 \mu\text{F}$

Parameter	Symbol	Conditions	Min	Typ	Max	Unit
Output voltage	$V_{OUT}$	$V_{IN} = 6.2 \text{ V}$ , $I_{OUT} = 50 \text{ mA}$	5.044	5.2	5.356	V
Input stability 1	$REG_{IN1}$	$V_{IN} = 6.2 \text{ V} \rightarrow 14.5 \text{ V}$ , $I_{OUT} = 50 \text{ mA}$	—	10	50	mV
Input stability 2	$REG_{IN2}$	$V_{IN} = 6.2 \text{ V} \rightarrow 9 \text{ V}$ , $I_{OUT} = 50 \text{ mA}$	—	5	20	mV
Load stability *1	$REG_{LOA}$	$V_{IN} = 6.2 \text{ V}$ , $I_{OUT} = 0 \text{ mA} \rightarrow 150 \text{ mA}$	—	50	150	mV
Peak output current *2	$I_{PEAK}$	$V_{IN} = 6.2 \text{ V}$ , The output current value decreases by 5% from the value when $V_{OUT}$ is at $I_{OUT} = 50 \text{ mA}$ .	180	240	—	mA
Bias current without load	$I_{BIAS}$	$V_{IN} = 6.2 \text{ V}$ , $I_{OUT} = 0 \text{ mA}$	—	—	350	$\mu\text{A}$
Bias current fluctuation with load	$\Delta I_{BIAS}$	$V_{IN} = 6.2 \text{ V}$ , $I_{OUT} = 0 \text{ mA} \rightarrow 150 \text{ mA}$	—	—	5	mA
Standby consumption current	$I_{STB}$	$V_{IN} = 10 \text{ V}$ , $V_{CONT} = 0 \text{ V}$	—	—	0.1	$\mu\text{A}$
Bias current before starting regulation	$I_{RUSH}$	$V_{IN} = 4.9 \text{ V}$ , $I_{OUT} = 0 \text{ mA}$	—	1.5	5	mA
Ripple rejection ratio	R.R.	$1 \text{ V}_{\text{rms}}$ , $f = 120 \text{ Hz}$ , $I_{OUT} = 10 \text{ mA}$	56	64	—	dB
Minimum input and output voltage difference 1	$V_{DIF(\text{min})1}$	$V_{IN} = 4.9 \text{ V}$ , $I_{OUT} = 0 \text{ mA}$	—	0.1	0.2	V
Minimum input and output voltage difference 2	$V_{DIF(\text{min})2}$	$V_{IN} = 5.3 \text{ V}$ , $I_{OUT} = 150 \text{ mA}$	—	—	0.4	V
Control terminal threshold high voltage	$V_{CONTH}$	$V_{IN} = 6.2 \text{ V}$ , $I_{OUT} = 50 \text{ mA}$	—	—	1.50	V
Control terminal threshold high voltage	$V_{CONTH}$	$V_{IN} = 6.2 \text{ V}$ , $I_{OUT} = 50 \text{ mA}$	0.30	—	—	V
Control terminal current	$I_{CONT}$	$V_{IN} = 6.2 \text{ V}$ , $I_{OUT} = 50 \text{ mA}$ $V_{CONT} = 1.8 \text{ V}$	—	—	30	$\mu\text{A}$

Note) \*1 :  $1.0 \Omega$

\*2 : Peak output current : The output current when the output voltage has been decreased by 5% from the value at the time of the output current is 50 mA due to the overcurrent protection.

## • Design reference data

Note) The following values are typical and not guaranteed values.

Parameter	Symbol	Conditions	Min	Typ	Max	Unit
Output noise voltage	$V_{NO}$	$10\text{Hz} \leq f \leq 100\text{kHz}$ , $I_{OUT} = 10 \text{ mA}$	—	108	—	$\mu\text{V}$
Output voltage temperature coefficient	$\frac{1}{V_{OUT}} \cdot \frac{dV_{OUT}}{dT}$	$V_{IN} = 6.2 \text{ V}$ , $I_{OUT} = 0 \text{ mA}$ $-30^\circ\text{C} \leq T_a \leq +85^\circ\text{C}$	—	90	—	ppm/ $^\circ\text{C}$
Output rise time	$t_{ON}$	$V_{IN} = 6.2 \text{ V}$ , $I_{OUT} = 50 \text{ mA}$ $V_{CONT} = 0 \text{ V} \rightarrow 1.8 \text{ V}$ , $C_{IN} = 0.1 \mu\text{F}$ $C_{OUT} = 10 \mu\text{F}$ , $V_{OUT} = 90\%$	—	0.20	—	ms

Note) \*1 : Refer to ■ Technical Information " • Output rise time characteristics".

AN80LXXRMS series Technical Information and etc.

■ Technical Information

- $P_D - T_a$  curves of Mini-type 5-pin package (Common to AN80LXXRMS series)

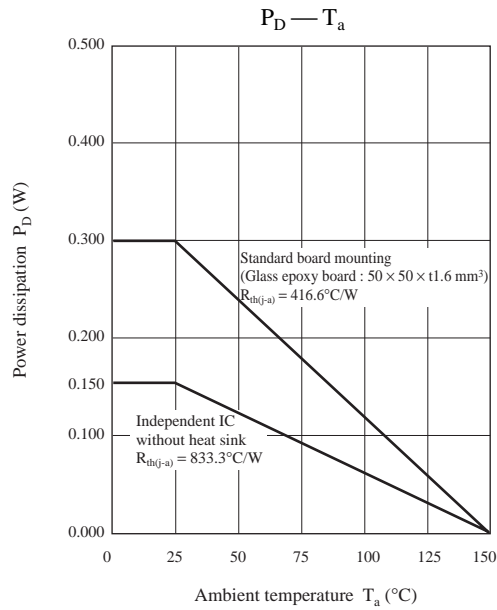

- ESR characteristics (Common to AN80LXXRMS series)

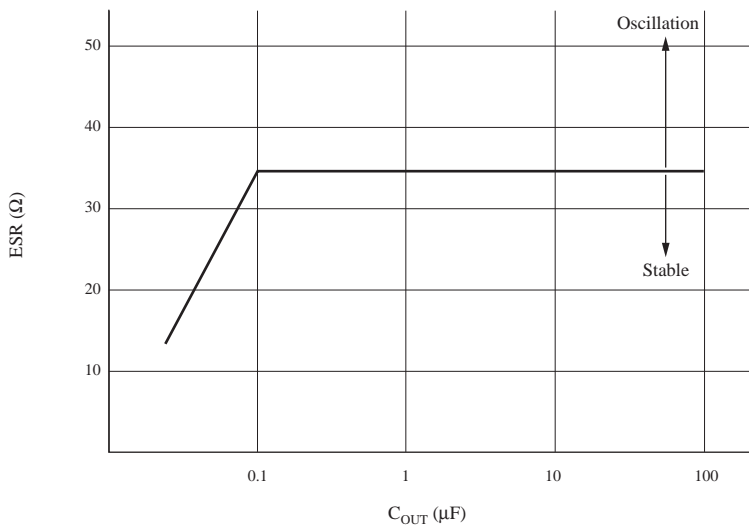

■ Technical Information (continued)

• ESR characteristics (Common to AN80LXXRMS series)

Test circuit

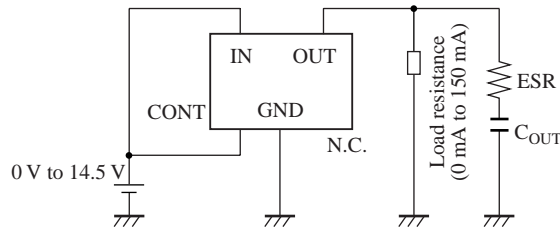

Note) 1. Not guaranteed values

2. The capacitance value used for  $C_{OUT}$  must be  $0.22 \mu\text{F}$  or more and  $100 \mu\text{F}$  or less. The recommended value is  $10 \mu\text{F}$ .
3. Use a capacitor having ESR (equivalent series resistance of capacitor) of  $35 \Omega$  or less (at  $T_a = -30^\circ\text{C}$  to  $+85^\circ\text{C}$ ).

• Output rise-time characteristics (Common to AN80LXXRMS series)

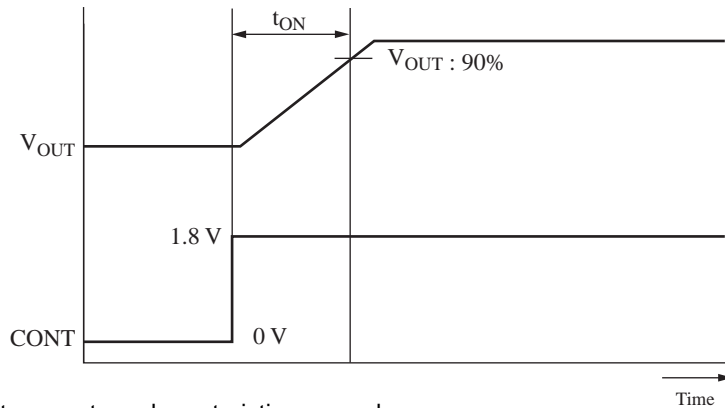

• Output voltage - temperature characteristics examples

<AN80L18RMS>

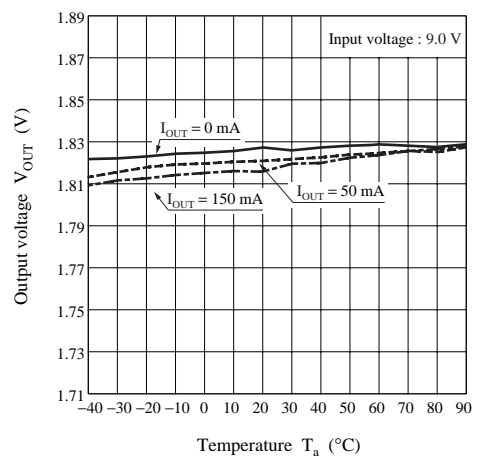
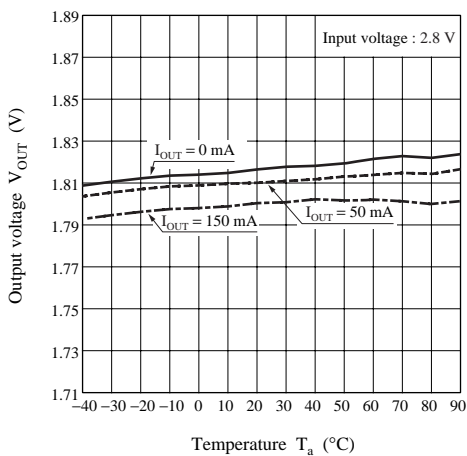

■ Technical Information (continued)

- Output voltage - temperature characteristics examples (continued)

<AN80L20RMS>

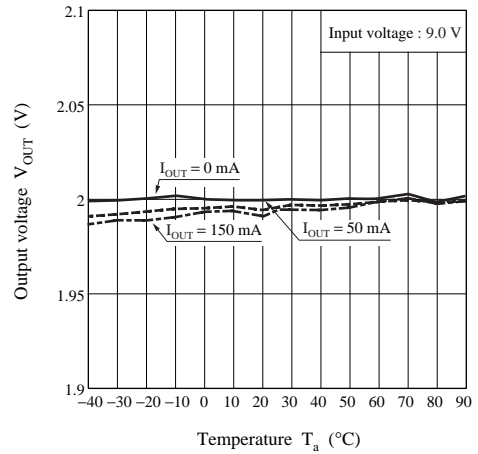
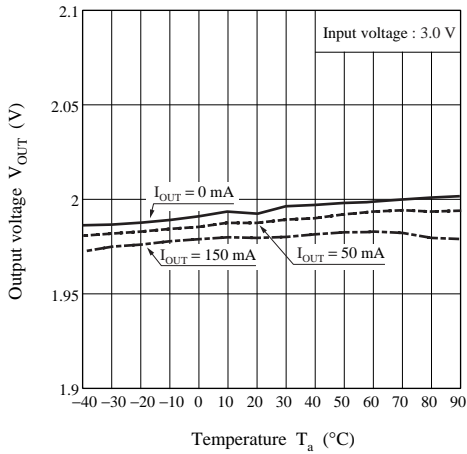

<AN80L33RMS>

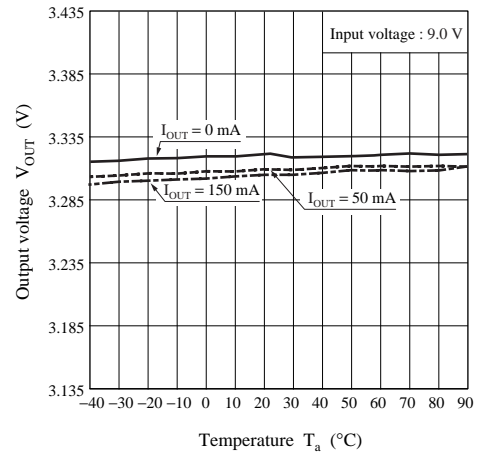
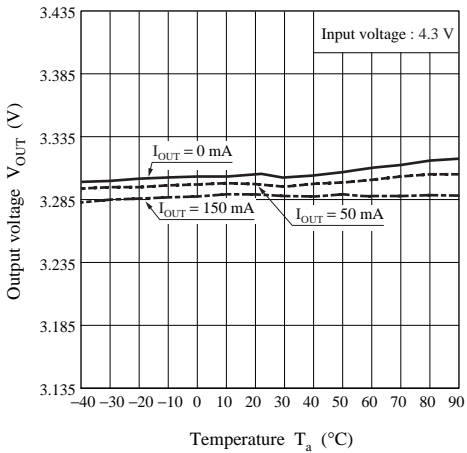

■ Application Circuit Example (Common to AN80LXXRMS Series)

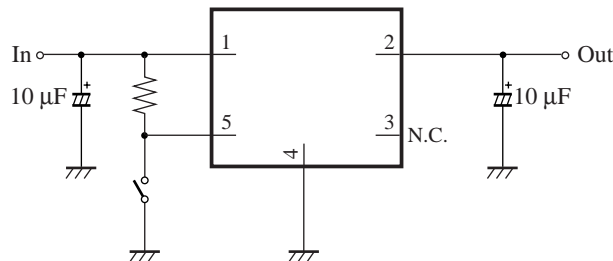

Output off when Low  
Output on when High



LittleDiode supplies new, hard to find or obsolete electronic components and semiconductors all over the world.

With over two million different components listed you are sure to find the part you need.

Feel free to visit us today at our online store:

[LittleDiode.com](http://LittleDiode.com)

Looking forward to providing you with the best possible service.