

# AN8060, AN8060S

## Low Drop Type Negative Output ( $-4V$ ) Regulator with Reset Pin

### ■ Overview

The AN8060 and the AN8060S are the low drop type regulators having the function of resetting output voltage. With a comparator to sense reduced voltage building it is suitable for batteries operation.

### ■ Features

- With reset function : bias current at resetting  $-5\mu A$
- Small input-output voltage difference :  $I_O=30mA$ ,  $0.2V$
- Low Supply Voltage sensing comparator built-in

### ■ Pin Descriptions

Pin No.	Symbol	Pin name
1	GND	GND
2	$V_I$	Input voltage
3	$V_O$	Output voltage
4	$C_{ADJ}$	Low supply voltage sensing adj.
5	RSENSE	Low supply voltage sensing output
6	RESET	Reset pin
7	$D_{IC}$	Diode pin (Cathode)
8	$D_{IA}$	Diode pin (Anode)

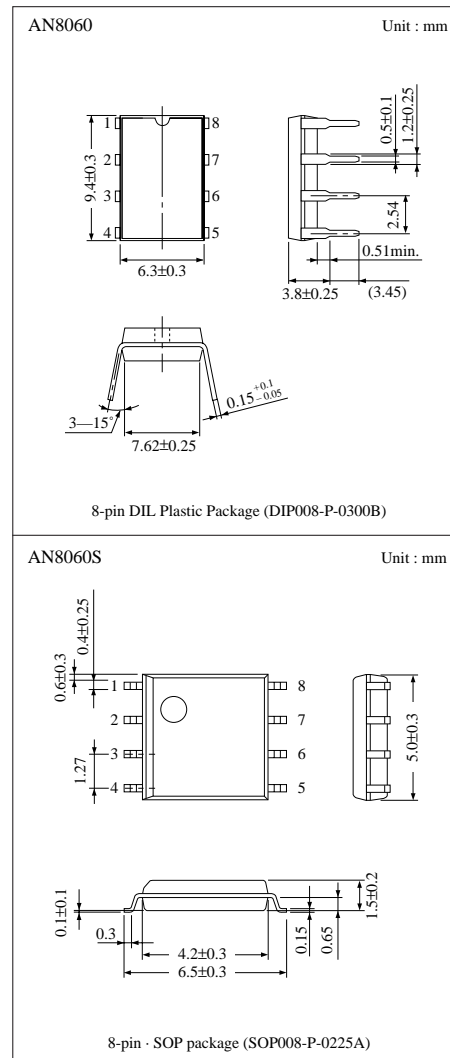

## ■ Block Diagram

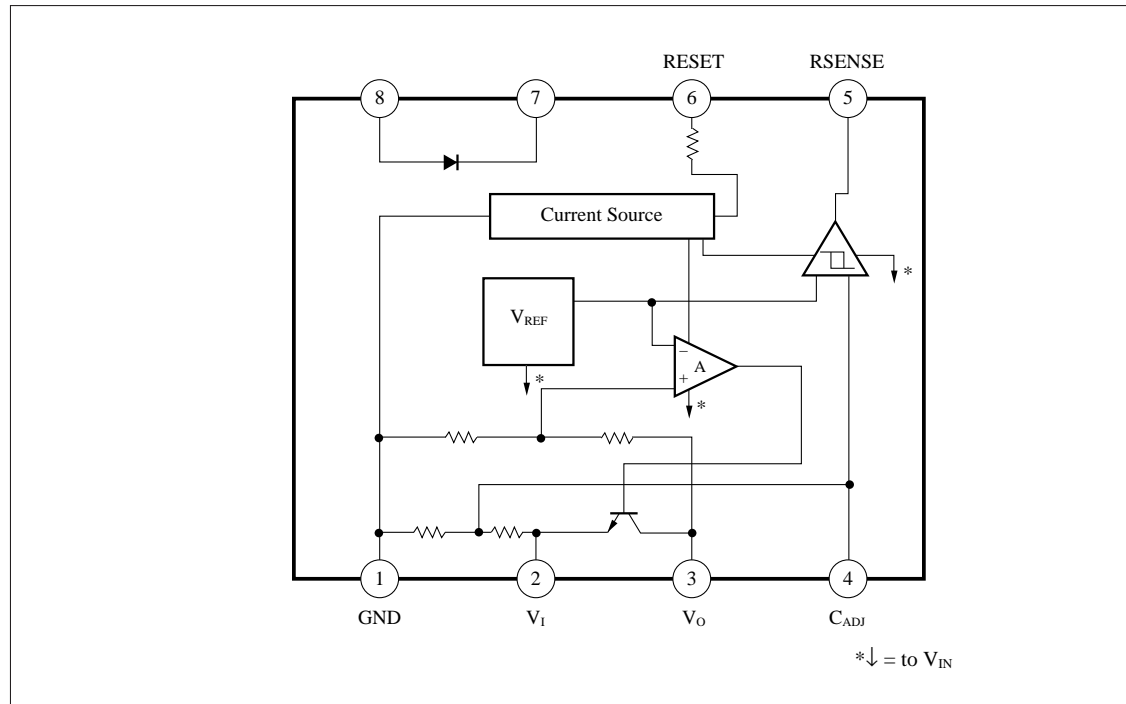

## ■ Absolute Maximum Ratings (Ta=25°C)

Parameter	Symbol	Rating	Unit
Supply voltage	$V_{CC}$	-12 to +0.3	V
Supply current	$I_{CC}$	—	mA
Power dissipation	$P_D$	AN8060	500
		AN8060S	361
Operating ambient temperature	$T_{opr}$	-20 to +75	°C
Storage temperature	$T_{sig}$	AN8060	-55 to +150
		AN8060S	-55 to +125

## ■ Electrical Characteristics (Ta=25°C)

Parameter	Symbol	Condition	min	typ	max	Unit
Bias current at reset	$I_{RB}$	$V_{RESET}=0V, V_I=-6V$	—	—	5	$\mu A$
Bias current at no load	$I_{UB}$	$V_I=-6V$	—	2.5	6	mA
Output voltage	$V_O$	$V_I=-6V, I_O=10mA$	-4.08	-3.92	-3.76	V
Output voltage tolerance	$V_T$	$V_I=-4.4$ to $-8V, I_O=1$ to $30mA$	-4.06	—	-3.66	V
Stable input voltage	$V_{IS}$	$V_I=-4.4$ to $-7.4V, I_O=10mA$	—	3.6	60	mV
Stable lock voltage	$V_{LS}$	$V_I=-6V, I_O=1$ to $30mA$	—	8	60	mV
Input/Output voltage difference	$V_{IOS}$	$V_I=-3.8V, I_O=30mA$	—	0.1	0.2	V
Reset pin input current (H)	$I_{RICH}$	$V_I=-6V, V_{RESET}=0V$	-1	—	—	$\mu A$
Reset pin input current (L)	$I_{RICL}$	$V_I=-6V, V_{RESET}=-6V$	-200	—	—	$\mu A$
Low supply voltage sending level	$V_{RDL}$	$I_O=10mA$	-4.55	-4.3	-4.05	V
Output voltage at reset	$V_{RO}$	$V_{RESET}=0V, V_I=-6V$	-0.1	—	—	V
Comparator output current	$I_{CO}$	$V_I=-4V, V_{RSENSE}=-3.6V$	1	—	—	mA

## ■ Characteristics Curve

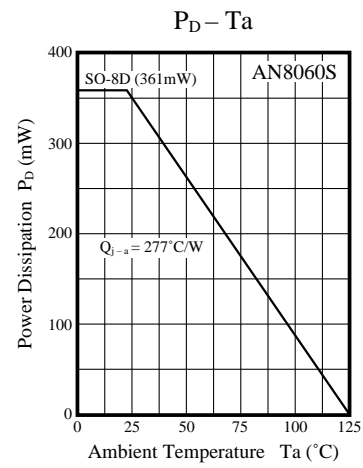
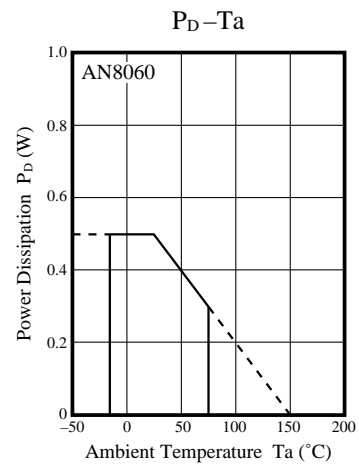



LittleDiode supplies new, hard to find or obsolete electronic components and semiconductors all over the world.

With over two million different components listed you are sure to find the part you need.

Feel free to visit us today at our online store:

**[LittleDiode.com](http://LittleDiode.com)**

Looking forward to providing you with the best possible service.