

# AN8041S

## Liquid crystal backlight control IC

### ■ Overview

The AN8041S is an inverter control IC for liquid crystal backlight using PWM method. The output voltage of DC-DC converter and the current of cathode-ray tube can be controlled by using two error amplifiers, so that the system is designed easily.

Since the n-channel MOSFET can be directly driven, it is possible to construct a highly effective power supply.

### ■ Features

- Operating supply voltage: 3.6 V to 34 V \*
- Totem pole output circuit: Output current of  $\pm 500$  mA
- Built-in bootstrap circuit
- N-channel power MOSFET can be directly driven
- Built-in two error amplifier circuits allow both the voltage and current control
- Incorporating on/off functions (active-high control input, standby mode current is  $5 \mu\text{A}$  or less)
- Built-in timer latch short-circuit protection circuit
- Maximum oscillation frequency: 500 kHz

Note) \*: The voltage is limited to the range of 3.6 V to 17 V if used in a step-down circuit.

### ■ Applications

- LCD displays, digital still cameras, and PDAs

### ■ Block Diagram

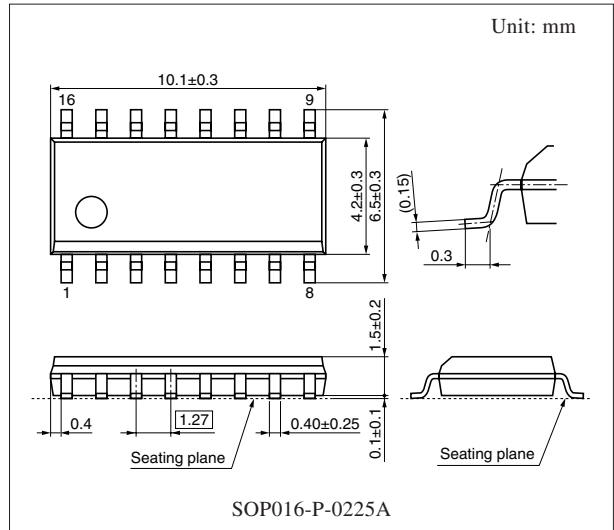
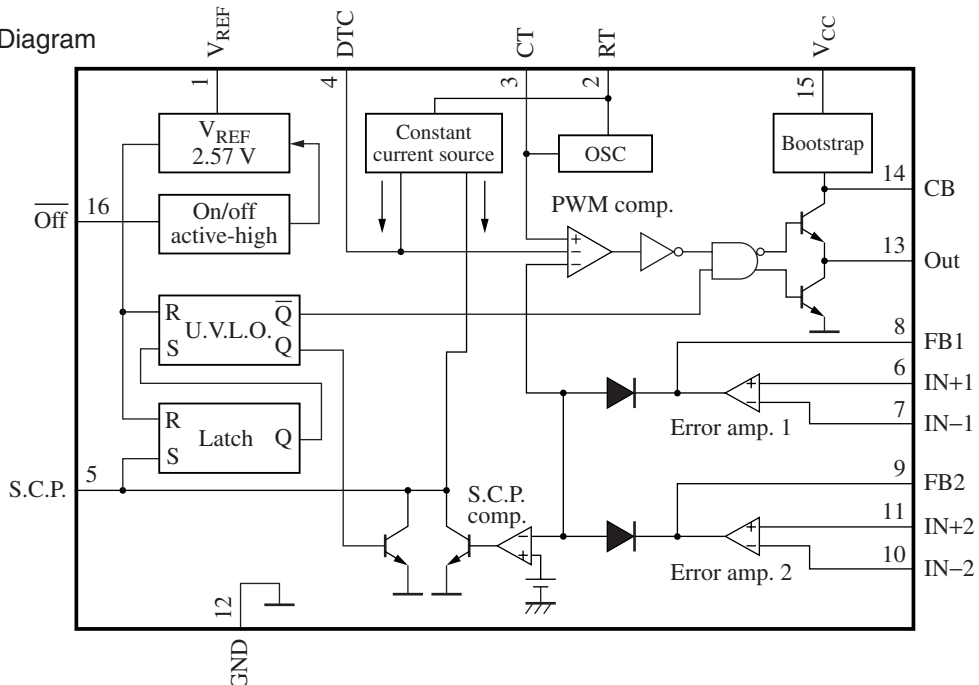

Note) The package of this product will be changed to lead-free type (SOP016-P-0225E). See the new package dimensions section later of this datasheet.

### ■ Pin Descriptions

| Pin No. | Symbol           | Description   | Pin No. | Symbol          | Description                             |
|---------|------------------|---|---------|-----------------|---|
| 1       | V <sub>REF</sub> | Reference voltage output pin  | 7       | IN-1            | Error amplifier 1 inverted input pin    |
| 2       | RT               | Pin for connecting oscillator timing resistor                                       | 8       | FB1             | Error amplifier 1 output pin            |
|         |                  |   | 9       | FB2             | Error amplifier 2 output pin            |
| 3       | CT               | Pin for connecting oscillator timing capacitor                                      | 10      | IN-2            | Error amplifier 2 inverted input pin    |
|         |                  |   | 11      | IN+2            | Error amplifier 2 noninverted input pin |
| 4       | DTC              | Dead-time control pin   | 12      | GND             | Grounding pin                           |
| 5       | S.C.P.           | Pin for connecting the time constant setting capacitor for short-circuit protection | 13      | Out             | Output pin                              |
|         |                  |   | 14      | CB              | Bootstrap output circuit                |
|         |                  |   | 15      | V <sub>CC</sub> | Power supply voltage application pin    |
| 6       | IN+1             | Error amplifier 1 noninverted input pin   | 16      | Off             | On/off control pin                      |

### ■ Absolute Maximum Ratings

| Parameter                            | Symbol               | Rating                   | Unit |
|--------------------------------------|----------------------|--------------------------|------|
| Supply voltage                       | V <sub>CC</sub>      | 35                       | V    |
| Off terminal application voltage     | V <sub>OFF</sub>     | 35                       | V    |
| Error amplifier input voltage        | V <sub>I</sub>       | -0.3 to V <sub>REF</sub> | V    |
| DTC terminal application voltage     | V <sub>DTC</sub>     | -0.3 to V <sub>REF</sub> | V    |
| Out terminal application voltage     | V <sub>OUT</sub>     | 35                       | V    |
| CB terminal application voltage      | V <sub>CB</sub>      | 35                       | V    |
| Out terminal constant output current | I <sub>O</sub>       | ±100                     | mA   |
| Out terminal peak output current     | I <sub>O(PEAK)</sub> | ±500                     | mA   |
| Power dissipation *                  | P <sub>D</sub>       | 143                      | mW   |
| Operating ambient temperature *      | T <sub>opr</sub>     | -30 to +85               | °C   |
| Storage temperature *                | T <sub>stg</sub>     | -40 to +125              | °C   |

Note) \*: Expect for the power dissipation, operating ambient temperature and storage temperature, all ratings are for T<sub>a</sub> = 25°C.

### ■ Recommended Operating Range

| Parameter                                     | Symbol           | Range        | Unit |
|---|------------------|--------------|------|
| Supply voltage (when using step-down circuit) | V <sub>CC</sub>  | 3.6 to 17    | V    |
| Supply voltage (when using step-up circuit)   | V <sub>CC</sub>  | 3.6 to 34    | V    |
| Oscillation frequency                         | f <sub>OUT</sub> | 5 to 500     | kHz  |
| Oscillator timing resistance                  | R <sub>T</sub>   | 5.1 to 30    | kΩ   |
| Oscillator timing capacitance                 | C <sub>T</sub>   | 100 to 10000 | pF   |
| Error amplifier input voltage                 | V <sub>IN</sub>  | -0.1 to +0.8 | V    |
| Reference voltage output current              | I <sub>REF</sub> | -1 to 0      | mA   |

**■ Electrical Characteristics at  $V_{CC} = 12\text{ V}$ ,  $R_T = 15\text{ k}\Omega$ ,  $C_T = 120\text{ pF}$ ,  $T_a = 25^\circ\text{C}$** 

| Parameter                                    | Symbol       | Conditions   | Min           | Typ           | Max   | Unit          |
|--|--------------|--|---------------|---------------|-------|---------------|
| <b>Reference voltage block</b>               |              |  |               |               |       |               |
| Output voltage                               | $V_{REF}$    | $I_{REF} = -1\text{ mA}$   | 2.483         | 2.57          | 2.647 | V             |
| Input regulation with input fluctuation      | Line         | $V_{CC} = 3.6\text{ V to }34\text{ V}$   | —             | 7             | 25    | mV            |
| Load regulation                              | Load         | $I_{REF} = -0.1\text{ mA to }-1\text{ mA}$                                     | —             | 1             | 10    | mV            |
| Output voltage temperature characteristics 1 | $V_{TC1}$    | $T_a = -30^\circ\text{C to }+25^\circ\text{C}$                                 | —             | $\pm 1$       | —     | %             |
| Output voltage temperature characteristics 2 | $V_{TC2}$    | $T_a = 25^\circ\text{C to }85^\circ\text{C}$                                   | —             | $\pm 1$       | —     | %             |
| Output short-circuit current                 | $I_{OS}$     |  | —             | -10           | —     | mA            |
| <b>U.V.L.O. block</b>                        |              |  |               |               |       |               |
| Circuit operation start voltage              | $V_{UON}$    |  | 2.8           | 3.1           | 3.4   | V             |
| Hysteresis width                             | $V_{HYS}$    |  | 60            | 140           | 220   | mV            |
| <b>Error amplifier block</b>                 |              |  |               |               |       |               |
| Input offset voltage                         | $V_{IO}$     |  | -6            | —             | 6     | mV            |
| Input bias current                           | $I_B$        |  | -500          | -25           | —     | nA            |
| Common-mode input voltage range              | $V_{ICR}$    |  | -0.1          | —             | 0.8   | V             |
| High-level output voltage 1                  | $V_{EH}$     |  | $V_{REF}-0.3$ | $V_{REF}-0.1$ | —     | V             |
| Low-level output voltage 1                   | $V_{EL}$     |  | —             | 0.1           | 0.3   | V             |
| Output sink current                          | $I_{SINK}$   | $V_{FB} = 0.9\text{ V}$  | —             | 8             | —     | mA            |
| Output source current                        | $I_{SOURCE}$ | $V_{FB} = 0.9\text{ V}$  | —             | -110          | —     | $\mu\text{A}$ |
| Open-loop gain                               | $A_G$        |  | —             | 70            | —     | dB            |
| <b>Dead-time control circuit block</b>       |              |  |               |               |       |               |
| Input current                                | $I_{DTC}$    | $R_T = 15\text{ k}\Omega$  | -14.8         | -12.3         | -9.8  | $\mu\text{A}$ |
| Low-level input threshold voltage            | $V_{DT-L}$   | Duty = 0%  | —             | 0.45          | 0.65  | V             |
| High-level input threshold voltage           | $V_{DT-H}$   | Duty = 100%  | 1.2           | 1.4           | —     | V             |
| <b>Output block</b>                          |              |  |               |               |       |               |
| Oscillation frequency                        | $f_{OUT}$    | $R_T = 15\text{ k}\Omega$ ,<br>$C_T = 120\text{ pF}$                           | 180           | 200           | 220   | kHz           |
| Output duty ratio                            | Du           | $R_{DTC} = 75\text{ k}\Omega$  | 45            | 50            | 55    | %             |
| Low-level output voltage                     | $V_{OL}$     | $I_O = 70\text{ mA}$   | —             | 1.0           | 1.3   | V             |
| High-level output voltage                    | $V_{OH}$     | $I_O = -70\text{ mA}$  | $V_{CB}-2.0$  | $V_{CB}-1.0$  | —     | V             |
| Frequency supply voltage characteristics     | $f_{dV}$     | $f_{OUT} = 200\text{ kHz}$ ,<br>$V_{CC} = 3.6\text{ V to }34\text{ V}$         | —             | $\pm 3$       | —     | V             |
| Frequency temperature characteristics 1      | $f_{dT1}$    | $f_{OUT} = 200\text{ kHz}$ ,<br>$T_a = -30^\circ\text{C to }+25^\circ\text{C}$ | —             | $\pm 9$       | —     | V             |
| Frequency temperature characteristics 2      | $f_{dT2}$    | $f_{OUT} = 200\text{ kHz}$ ,<br>$T_a = 25^\circ\text{C to }85^\circ\text{C}$   | —             | $\pm 9$       | —     | V             |

**■ Electrical Characteristics at  $V_{CC} = 12\text{ V}$ ,  $R_T = 15\text{ k}\Omega$ ,  $C_T = 120\text{ pF}$ ,  $T_a = 25^\circ\text{C}$  (continued)**

| Parameter                             | Symbol       | Conditions               | Min          | Typ          | Max          | Unit          |
|---------------------------------------|--------------|--------------------------|--------------|--------------|--------------|---------------|
| <b>Bootstrap circuit block</b>        |              |                          |              |              |              |               |
| Input standby voltage                 | $V_{INCB}$   | $I_{CB} = -70\text{ mA}$ | $V_{CC}-1.2$ | $V_{CC}-1.0$ | $V_{CC}-0.8$ | V             |
| <b>Oscillator block</b>               |              |                          |              |              |              |               |
| RT terminal voltage                   | $V_{RT}$     |                          | —            | 0.37         | —            | V             |
| <b>Short-circuit protection block</b> |              |                          |              |              |              |               |
| Input threshold voltage               | $V_{THPC}$   |                          | 0.70         | 0.75         | 0.80         | V             |
| Input standby voltage                 | $V_{STBY}$   |                          | —            | 30           | 120          | mV            |
| Input latch voltage                   | $V_{IN}$     |                          | —            | 30           | 120          | mV            |
| Charge current                        | $I_{CHG}$    |                          | -2.76        | -2.3         | -1.84        | $\mu\text{A}$ |
| Comparator threshold voltage          | $V_{THL}$    |                          | —            | 1.82         | —            | V             |
| <b>On/off control block</b>           |              |                          |              |              |              |               |
| Threshold voltage                     | $V_{TH}$     |                          | 0.8          | —            | 2.0          | V             |
| <b>Whole device</b>                   |              |                          |              |              |              |               |
| Total consumption current             | $I_{CC}$     |                          | —            | 3.9          | 5.0          | mA            |
| Standby current                       | $I_{CC(SB)}$ |                          | —            | —            | 5            | $\mu\text{A}$ |

**■ Terminal Equivalent Circuits**

| Pin No. | Equivalent circuit | Description  | I/O |
|---------|--------------------|--|-----|
| 1       |                    | $V_{REF}$ :<br>The reference voltage output terminal (2.57 V (allowance: $\pm 3\%$ )).<br>Incorporating short-circuit protection against GND.  | O   |
| 2       |                    | $R_T$ :<br>The terminal used for connecting a timing resistor to set oscillator's frequency.<br>Use a resistance value within the range of 5.1 k $\Omega$ to 30 k $\Omega$ .<br>The terminal voltage is approx. 0.37 V.  | —   |
| 3       |                    | $C_T$ :<br>The terminal used for connecting a timing capacitor to set oscillator's frequency.<br>Use a capacitance value within the range of 100 pF to 10 000 pF.<br>For frequency setting method, refer to the "Application Notes, [3] Function descriptions" section. Use an oscillation frequency in the range of 5 kHz to 500 kHz. | —   |

■ Terminal Equivalent Circuits (continued)

| Pin No. | Equivalent circuit | Description  | I/O |
|---------|--------------------|--|-----|
| 4       |                    | <p>DTC:</p> <p>The terminal for connecting a resistor and capacitor to set the dead-time and soft start period of PWM output. Input current <math>I_{DTC}</math> is determined by the timing resistor <math>R_T</math>, so that dispersion and fluctuation with temperature are suppressed. It is approx. <math>-12.3 \mu A</math> when <math>R_T = 15 k\Omega</math>.</p> $I_{DTC} = \frac{V_{RT}}{R_T} \times \frac{1}{2} [A]$   | —   |
| 5       |                    | <p>S.C.P.:</p> <p>The terminal for connecting a capacitor to set the time constant of soft start and timer latch short-circuit protection circuit.</p> <p>Use a capacitance value in the range of more than 1 000 pF.</p> <p>The charge current <math>I_{CHG}</math> is determined by the timing resistor <math>R_T</math>, so that dispersion and fluctuation with temperature are suppressed. It is approx. <math>-1.3 \mu A</math> when <math>R_T = 15 k\Omega</math>.</p> $I_{CHG} = \frac{V_{RT}}{R_T} \times \frac{1}{11} [A]$ | —   |
| 6       |                    | <p>IN+1:</p> <p>The noninverted input terminal of the error amplifier 1.</p> <p>For common-mode input, use in the range of <math>-0.1 V</math> to <math>+0.8 V</math>.</p>   | I   |
| 7       |                    | <p>IN-1:</p> <p>The inverted input terminal of the error amplifier 1.</p> <p>For common-mode input, use in the range of <math>-0.1 V</math> to <math>+0.8 V</math>.</p>  | I   |
| 8       |                    | <p>FB1:</p> <p>The output terminal of the error amplifier 1.</p> <p>Source current : approx. <math>-120 \mu A</math></p> <p>Sink current : approx. <math>8 mA</math></p> <p>Correct the frequency characteristics of the gain and the phase by connecting a resistor and a capacitor between this terminal and IN-1 terminal.</p>  | O   |
| 9       |                    | <p>FB2:</p> <p>The output terminal of the error amplifier 2.</p> <p>Source current : approx. <math>-120 \mu A</math></p> <p>Sink current : approx. <math>8 mA</math></p> <p>Correct the frequency characteristics of the gain and the phase by connecting a resistor and a capacitor between this terminal and IN-2 terminal.</p>  | O   |

### ■ Terminal Equivalent Circuits (continued)

| Pin No. | Equivalent circuit | Description  | I/O |
|---------|--------------------|--|-----|
| 10      |                    | IN-2:<br>The inverted input terminal of the error amplifier 2.<br>For common-mode input, use in the range of -0.1 V to +0.8 V.   | I   |
| 11      |                    | IN+2:<br>The noninverted input terminal of the error amplifier 2.<br>For common-mode input, use in the range of -0.1 V to +0.8 V.  | I   |
| 12      |                    | GND:<br>Grounding terminal.  | —   |
| 13      |                    | Out:<br>Totem pole type output terminal.<br>A constant output current of $\pm 100$ mA and a peak output current of $\pm 500$ mA can be obtained.   | O   |
| 14      |                    | CB:<br>Bootstrap output terminal.<br>When using step-down circuit, connect the capacitor for boost between this terminal and the n-channel MOSFET source side of the switching device.<br>When using step-up circuit, short circuit this terminal with V <sub>CC</sub> terminal. | O   |
| 15      |                    | V <sub>CC</sub> :<br>Power supply application terminal.  | I   |
| 16      |                    | Off:<br>On/off control terminal.<br>High-level input: normal operation ( $V_{OFF} > 2.0$ V)<br>Low-level input: standby condition ( $V_{OFF} < 0.8$ V)<br>The total consumption current can be suppressed to 10 $\mu$ A or less.   | I   |

■ Application Notes

[1] Main characteristics

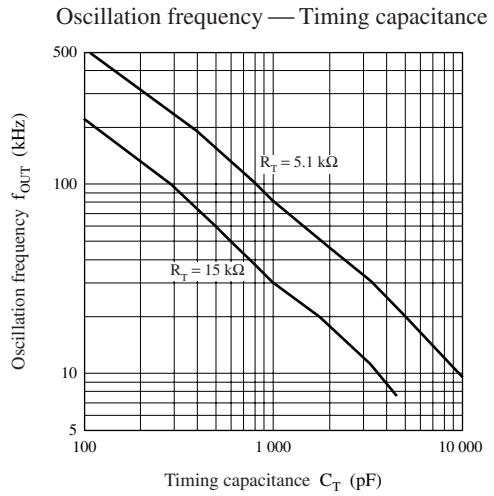
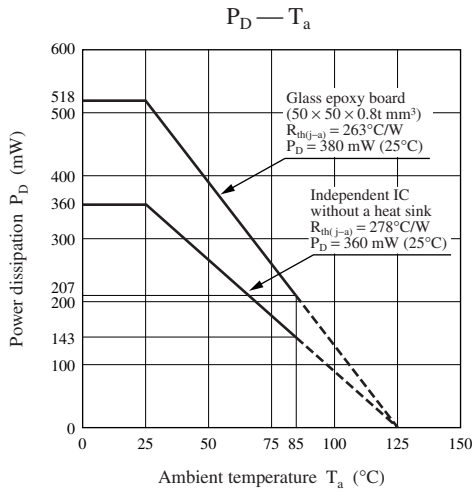

Oscillation frequency temperature characteristics

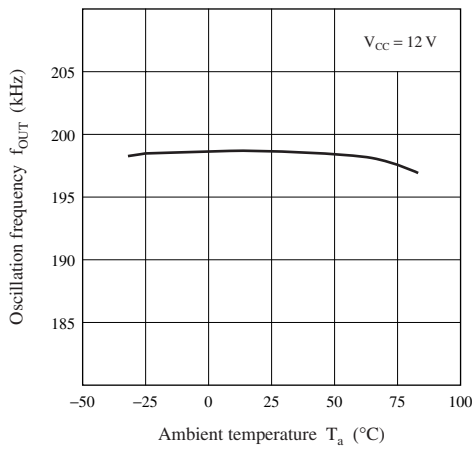

Output duty ratio temperature characteristics

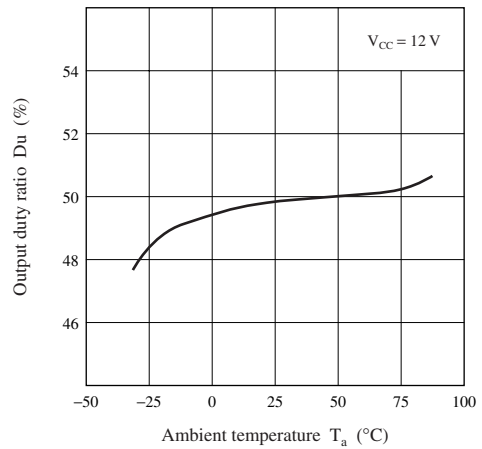

Internal reference voltage temperature characteristics

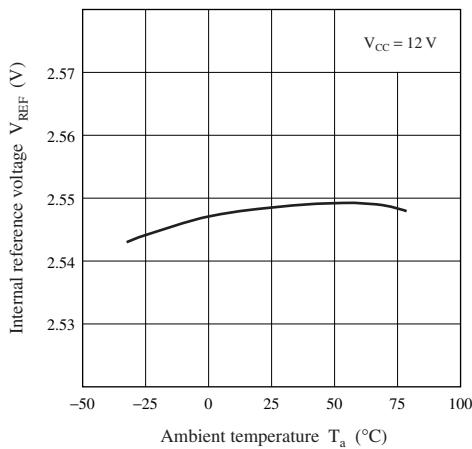

Output duty ratio — DTC terminal voltage

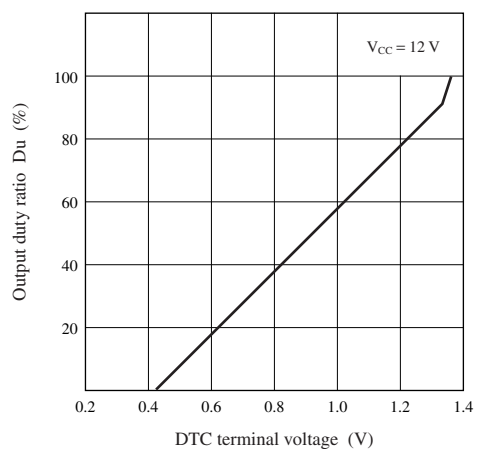

■ Application Notes (continued)

[2] Timing chart

1. PWM comparator operation waveform

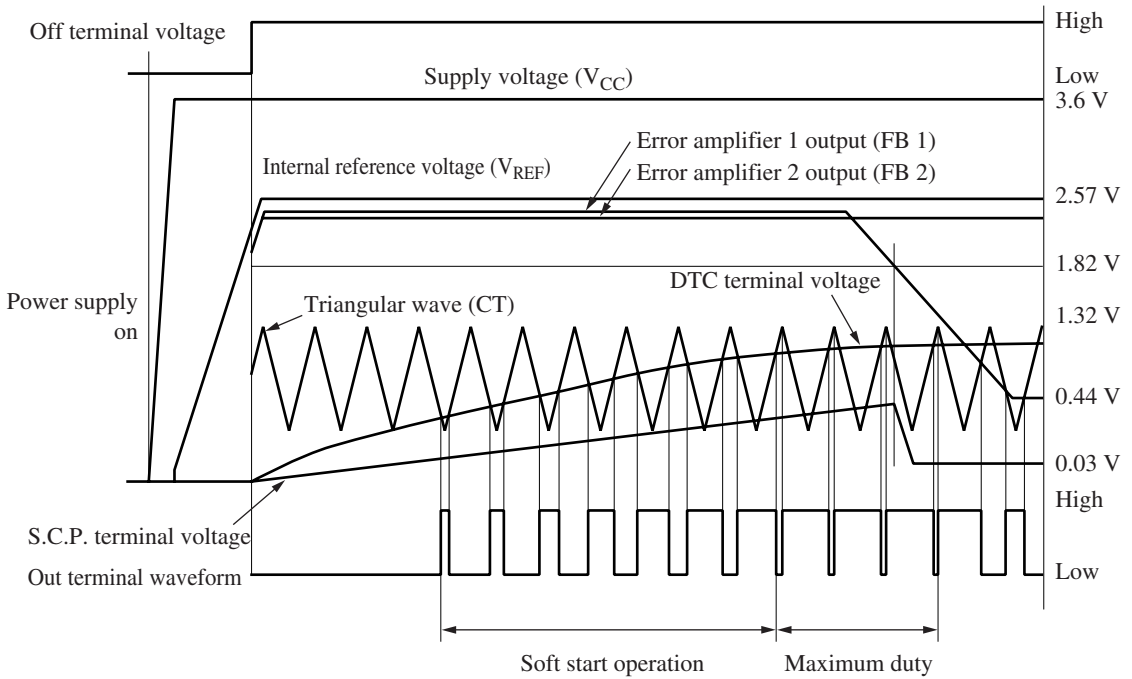

2. Short-circuit protection operation waveform

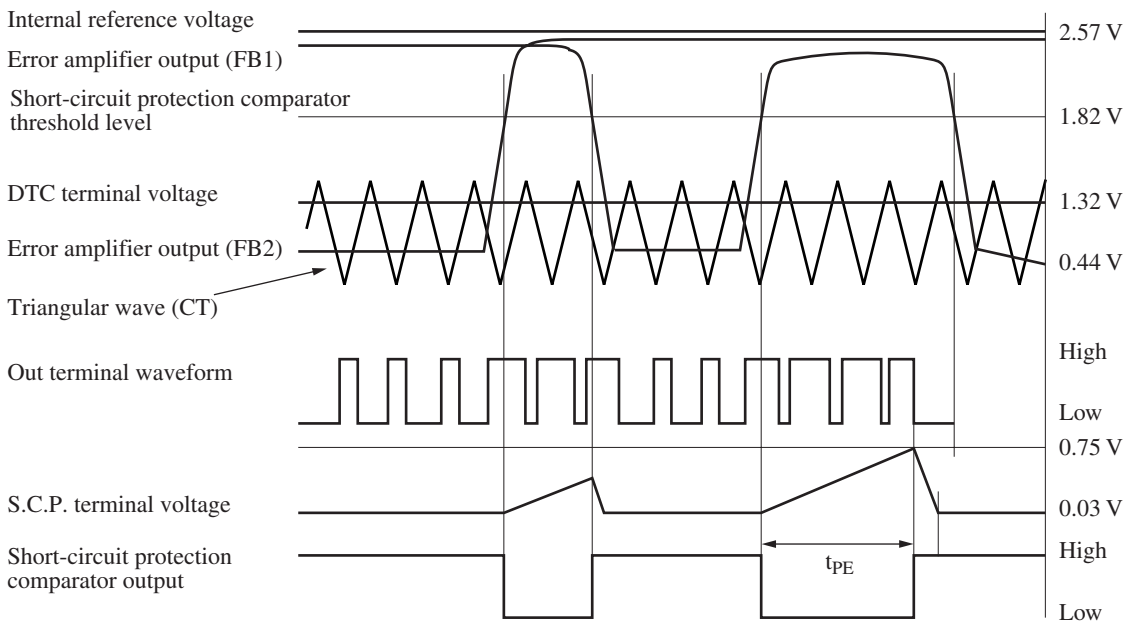

■ Application Notes (continued)

[3] Function descriptions

1. Reference voltage block

This block is composed of the band gap circuit, and outputs the temperature-compensated 2.57 V reference voltage to the  $V_{REF}$  terminal (pin 16). The reference voltage is stabilized when the supply voltage is 3.6 V or higher, and used as the operating power supply for the IC inside. It is possible to take out a load current of up to  $-1$  mA.

2. Triangular wave oscillation block (OSC)

The triangular wave which swings from the upper limit value  $V_{OSCH}$  of approximately 1.32 V to the lowest limit value  $V_{OSCL}$  of approximately 0.44 V will be generated by connecting a timing capacitor  $C_T$  and a resistor  $R_T$  to the  $C_T$  terminal (pin 2) and  $R_T$  terminal (pin 3) respectively. The oscillation frequency can be arbitrarily decided by the value of timing capacitor  $C_T$  and resistor  $R_T$  connected externally. The oscillation frequency  $f_{OSC}$  is obtained by the following calculations:

$$f_{OSC} = \frac{1}{t_1 + t_2} = \frac{I_O}{2 \times C_T \times (V_{CTH} - V_{CTL})}$$

$$I_O = \frac{1.7 \times V_{RT}}{R_T} = \frac{1.7 \times 0.37}{R_T}$$

Since  $V_{CTH} - V_{CTL} = 0.88$  V,

$$\text{therefore } f_{OSC} \approx \frac{1}{2.80 \times C_T \times R_T} \text{ [Hz]}$$

Example) When  $C_T = 100$  [pF],  $R_T = 15$  [kΩ],  
 $f_{OSC} \approx 238$  [kHz].

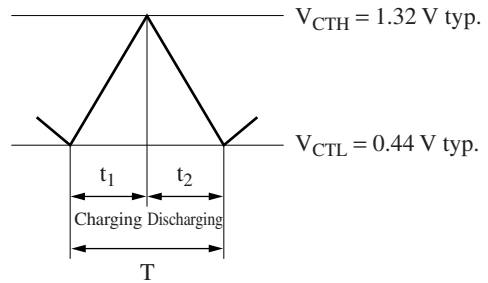

Figure 1. Triangular wave oscillation waveform

It is possible to use the circuit in the recommended operating range of 5 kHz to 500 kHz of the oscillation frequency. In addition, when the oscillation frequency becomes high, overshoot and undershoot are generated due to the operation delay of the triangular oscillation comparator. Care should be taken because the actual measurement values deviate from the above calculation values.

In the case of this IC, the output source current of S.C.P. terminal and DTC terminal are set by the timing resistor  $R_T$  externally attached to  $R_T$  terminal. For this reason, the AN8041S can not be used as a slave IC when multiple ICs are synchronously operating in parallel.

3. Error amplifier 1 block and error amplifier 2 block

DC-DC output voltage and a detected lamp current of back-light are amplified through the PNP transistor input type error amplifier, and the amplified signal are inputted to PWM comparator.

Figure 2 shows the connection method of the error amplifier when the backlight inverter is controlled. Select the connection of error amplifier 1 block or 2 block arbitrarily.

The common-mode input range is from  $-0.1$  V to  $+0.8$  V. The voltage which is resistor-dividing of the reference voltage is given to the noninverted input. Also, any desired gain setting and phase compensation can be obtained by connecting the feedback resistor and capacitor from the error amplifier output terminals (pin 8 and pin 9) to the inverted input terminals (pin 7 and pin 10).

The overshoot at operation start due to feedback delay can be suppressed by providing the large output source current (110  $\mu$ A) and the large output sink current (8 mA).

The output voltage  $V_{OUT}$  and the detection voltage of the lamp current  $V_{CI}$  are given from the following calculation:

$$V_{IN+} = V_{REF} \times \frac{R_4}{R_3 + R_4}$$

$$V_{OUT} = V_{IN+1} \times \frac{R_1 + R_2}{R_2}$$

$$V_{CI} = V_{IN+2} \times \frac{R_5 + V_R + R_6}{R_5 + V_R}$$

■ Application Notes (continued)

[3] Function descriptions (continued)

3. Error amplifier 1 block and error amplifier 2 block (continued)

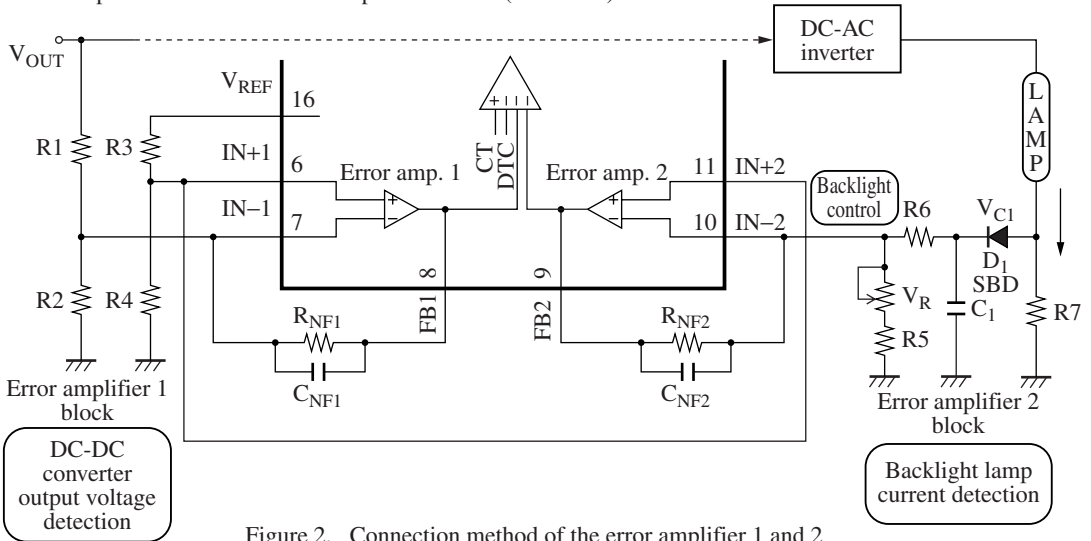

Figure 2. Connection method of the error amplifier 1 and 2

The control modes of backlight are described below:

1) Power-on mode

When the power supply is turned on, the DC-DC converter which is connected to the error amplifier 1 block starts the control.

The output voltage  $V_{OUT}$  which has been set by the equation in the previous page is reached, and the high voltage of several kV is generated in the lamp through the DC-AC inverter, and the backlight is lighted up. During this period, since the lamp current does not flow in the error amplifier 2 block, the error amplifier output (FB2) becomes high-level, so that its control does not work.

2) Normal control mode

When the backlight is turned on, discharging starts and the current starts to flow in the resistor R7.

When the voltage  $V_{C1}$  rectified by diode D1, and capacitor C1 reaches the voltage set by resistors R5, R6, and volume control  $V_R$ ; The control function is switched over from the error amplifier 1 block to the error amplifier 2 block. The output voltage of the DC-DC converter  $V_{OUT}$  decreases to a voltage lower than the set voltage, and the lamp voltage is maintained at several hundred volts.

3) Light-regulation operation mode

For the light regulation of the backlight, the "voltage light-regulation" method is used, and the light is regulated by the input voltage of the inverter. By adding volume  $V_R$  to the inverted input terminal of error amplifier 2 block to make the detection voltage  $V_{C1}$  variable, the input voltage of the inverter is regulated so as to make the lamp current variable for light regulation.

Also, the addition of the volume to the noninverted input side of the error amplifier makes the light regulation possible.

• Usage notes

When this IC is used to control the DC-DC converter, one of two error amplifiers is not used. Connection should be made so that the FB terminal is fixed to high-level as shown in figure 3.

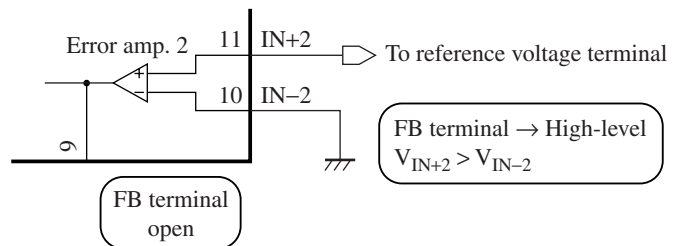

Figure 3. Connection when the error amplifier 2 block is not used

## ■ Application Note (continued)

### [3] Function descriptions (continued)

#### 4. Timer latch short-circuit protection circuit

When the short-circuit or overload of the power supply output continues for a certain period, this circuit prevents the parts such as external main switch device, flywheel diode, the choke coil from destruction or deterioration.

The short-circuit protection circuit is shown in figure 4. The timer latch short-circuit protection circuit detects the output level of the error amplifier 1 and 2 blocks. When either the DC-DC converter output voltage or the lamp current detection voltage is stable, the output of that error amplifier is stabilized and the short-circuit protection comparator also maintains balance.

When the load conditions are suddenly changed, and both of the outputs of the error amplifier 1 block and 2 block (FB1, FB2) become 1.82 V or higher, the short-circuit protection comparator outputs low-level and cut off the transistor Q1, thereby the external capacitor  $C_S$  of the S.C.P. terminal (pin 5) starts charging with current  $I_{CHG}$  given by the following equation:

$$V_{PE} = V_{STBY} + I_{CHG} \times \frac{t_{PE}}{C_S} \quad [V]$$

$$0.75 \text{ V} = 0.03 \text{ V} + I_{CHG} \times \frac{t_{PE}}{C_S}$$

$$C_S = I_{CHG} \times \frac{t_{PE}}{0.72} \quad [F]$$

$I_{CHG}$  is constant current which is determined by the timing resistor  $R_T$  of the oscillator. It becomes approximately 2.3  $\mu\text{A}$  when  $R_T = 15 \text{ k}\Omega$ .

$$I_{CHG} = \frac{V_{RT} \times 1}{R_T \times 11} \quad [A]$$

When the external capacitor  $C_S$  is charged to approximately 0.75 V, the latch circuit is set to fix the totem pole output terminal to low-level and sets the dead-time to 100%.

When the latch circuit is set, the S.C.P. terminal voltage is discharged to approximately 30 mV. However, once the latch circuit is set, it is not reset unless the power supply is turned off.

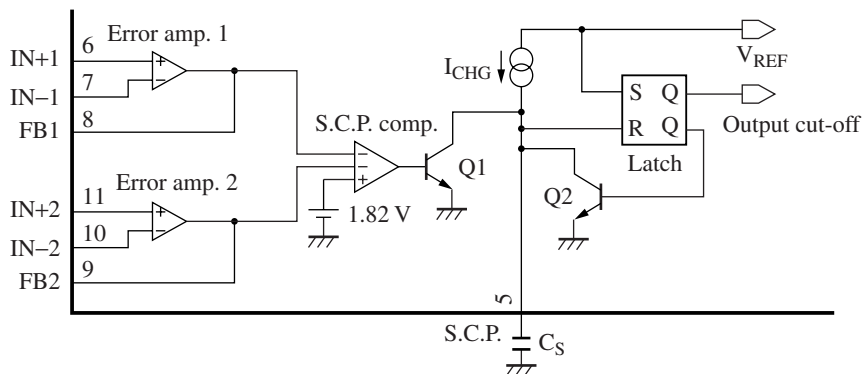

Figure 4. Short-circuit protection circuit

#### 5. Low input voltage malfunction prevention circuit (U.V.L.O.)

When the supply voltage is dropped under the transient condition such as power-on or operation stop, this circuit protects the system from destruction or deterioration due to the malfunction of the control circuit.

This circuit detects the internal reference voltage which varies according to the supply voltage level. During the period from the time when the supply voltage starts to rise and to the time when it reaches 3.1 V, it keeps the dead-time of the Out terminal (pin 13) to 100% and maintains the DTC terminal (pin 4) and the S.C.P. terminal (pin 5) at low-level. When the supply voltage falls, it holds the hysteresis width of 140 mV and operates at a voltage under 2.96 V.

## ■ Application Notes (continued)

### [3] Function descriptions (continued)

#### 6. Remote circuit

The IC control function can be turned on or off by the external control. When the voltage of Off terminal (pin 16) is set under approximately 0.8 V, the internal reference voltage falls to stop the IC control function, and decrease the circuit current to a value under 5  $\mu\text{A}$ . When the voltage of Off terminal is set at a value higher than approximately 2.0 V, the internal reference voltage rises, and starts the control operation.

#### 7. PWM comparator block

The PWM comparator controls the on-period of the output pulse according to the input voltage. While the voltage of triangular wave of the CT terminal (pin 3) is lower than any one of the output of the error amplifier 1 and 2 block (pin 8 and pin 9) and the voltage of the DTC terminal (pin 4), it sets the Out terminal (pin 13) to high-level so that the switching device (n-channel MOSFET) turns on.

The dead-time is set by regulating the DTC terminal voltage  $V_{\text{DTC}}$  as shown in figure 5.

The DTC terminal is of a constant current output using the resistor  $R_{\text{T}}$ , so that the  $V_{\text{DTC}}$  is regulated by connecting the external resistor  $R_{\text{DTC}}$  between the DTC terminal and GND terminal.

At the oscillation frequency  $f_{\text{OSC}}$  of 200 kHz, the output duty ratio becomes 0% when  $V_{\text{DTC}} = 0.44$  V typical, and 100% when  $V_{\text{DTC}} = 1.32$  V typical.

However, pay attention to the peak value  $V_{\text{CTH}}$  and the trough value  $V_{\text{CTL}}$  of the triangular wave because their overshoot and undershoot amount differ depending on the oscillation frequency.

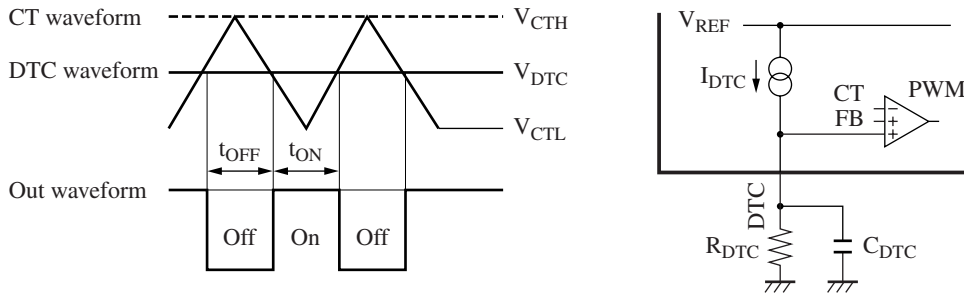

Figure 5. Setting the dead-time

The output duty ratio  $Du$  and the DTC terminal voltage  $V_{\text{DTC}}$  are given in the following equation:

$$\begin{aligned}
 Du &= \frac{t_{\text{ON}}}{t_{\text{ON}} + t_{\text{OFF}}} \times 100 \quad [\%] & I_{\text{DTC}} &= \frac{V_{\text{RT}}}{R_{\text{T}}} \times \frac{1}{2} \quad [\text{A}] \\
 &= \frac{V_{\text{DTC}} - V_{\text{CTL}}}{V_{\text{CTH}} - V_{\text{CTL}}} \times 100 \quad [\%] & V_{\text{DTC}} &= I_{\text{DTC}} \times R_{\text{DTC}} \\
 & & &= V_{\text{RT}} \times \frac{R_{\text{DTC}}}{R_{\text{T}}} \times \frac{1}{2} \quad [\text{A}]
 \end{aligned}$$

Example) When  $f_{\text{OSC}} = 200$  [kHz] ( $R_{\text{T}} = 15$  k $\Omega$ ,  $C_{\text{T}} = 150$  pF),  $R_{\text{DTC}} = 75$  [k $\Omega$ ]  
 $V_{\text{CTH}} \approx 1.32$  [V],  $V_{\text{CTL}} \approx 0.44$  [V],  $V_{\text{DTC}} \approx 0.37$  [V]  
 Therefore  $I_{\text{DTC}} \approx 12.3$  [ $\mu\text{A}$ ]  
 $V_{\text{DTC}} \approx 0.925$  [V]  
 $Du \approx 55.1$  [%]

In addition, the operation delay of the PWM comparator, the deviation of the peak and trough triangular oscillation value may cause the deviation of the actual measurements value from the theoretical value. So, regulation on IC-mounted PCB should be required.

By adding the external resistor  $R_{\text{DTC}}$  and capacitor  $C_{\text{DTC}}$ , the soft start function can be installed, which gradually broadens the on-period of the output pulse at the time of the power supply operation start. The soft start operation prevents the overshoot of DC-DC comparator output.

■ Application Notes (continued)

[3] Function descriptions (continued)

8. Output block, bootstrap circuit

In the case of the step-down type DC-DC converter control, the bootstrap circuit is required if n-channel MOSFET is used as the switching device.

The bootstrap circuit is used for keeping the voltage between the gate and the source higher than the gate threshold voltage of n-channel MOSFET by increasing the high-level of the Out terminal (pin 13) to a level higher than  $V_{CC}$  when turning on the n-channel MOSFET. The output block including the external circuit and the bootstrap circuit are shown in figure 6, and the operation waveform in figure 7.

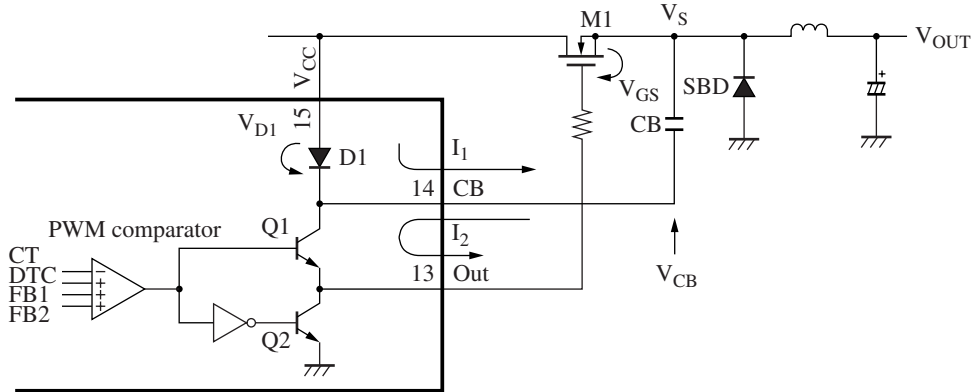

Figure 6. Output block and bootstrap circuit

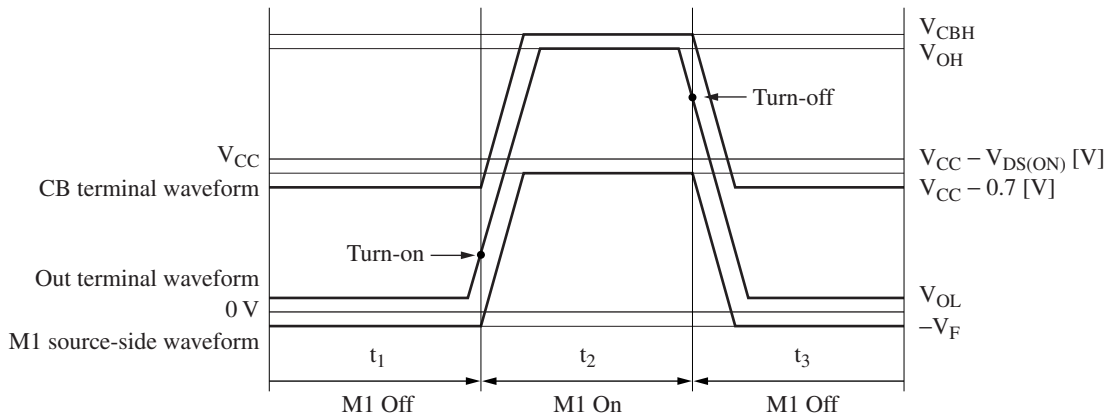

Figure 7. Bootstrap circuit operation waveform

The bootstrap circuit operation is described below.

1) N-channel MOSFET (M1) off time:  $t_1$

While the M1 is off, energy is being supplied from the Schottky barrier diode (SBD) to the choke coil, and the M1 source side voltage  $V_S$  is fixed to  $-V_F$ . The capacitor for boost  $C_B$  is charged from the  $V_{CC}$  terminal (pin 15) through the diode inside the IC (D1). The  $C_B$  terminal voltage (pin 14)  $V_{CB}$  is given by the following equation:

$$V_S = -V_F$$

$$V_{CB} = V_{CC} - V_{D1}$$

$V_F$  : forward voltage of SBD  
 $V_{D1}$  : forward voltage of D1

Therefore, the charged voltage of boost  $C_B$  is given by the following equation:

$$V_{CB} - V_S = V_{CC} - V_{D1} + V_F$$

## ■ Application Notes (continued)

### [3] Function descriptions (continued)

#### 8. Output block, bootstrap circuit (continued)

##### 2) N-channel MOSFET (M1) turn-on time: $t_2$

When the PWM comparator output reverses, the Out terminal (pin 13) is switched over to high-level. The Out terminal voltage  $V_O$  rises toward the CB terminal voltage.

$$V_O = V_{CB} - V_{CE}(\text{sat})$$

At that time, M1 voltage between the gate and source becomes:

$$V_{GS} = V_O + V_F$$

When the Out terminal voltage  $V_O$  rises to the gate threshold voltage, the M1 is turned on. The M1 source-side voltage after the turn-on rises to the value expressed in the following equation:

$$V_S = V_{CC} - V_{DS(\text{ON})}$$

Since the bootstrap capacitor  $C_B$  is connected between the M1 source-side and the CB terminal, the CB terminal voltage is capacitance-coupled, and rises according to the M1 source-side voltage. It is expressed in the following equation:

$$\begin{aligned} V_{CB} &= V_S + V_{CC} - V_{D1} + V_F \\ &= 2 \times V_{CC} - V_{D1} + V_{DS(\text{ON})} + V_F \end{aligned}$$

##### 3) N-channel MOSFET (M1) turn-off time: $t_3$

The Out terminal voltage drops to the saturation voltage of the transistor Q1 and it is turned off.

The M1 source side voltage decreases to  $-V_F$ , and in the same way the CB terminal voltage is capacitance-coupled, and drops to  $V_{CC} - V_{D1}$  volt, and returns to the condition described in a).

#### • Bootstrap circuit usage notes

##### (1) Operating supply voltage range when the step-down circuit is used

When the step-down circuit is used for the DC-DC converter control : As described in the above, when the n-channel MOSFET of the switching device turns on, the voltage of CB terminal (pin 14) rises to the voltage about two times higher than the  $V_{CC}$ . Since the allowable applied voltage for the CB terminal is 35 V, use the boost circuit at an operating supply voltage of 3.6 V or more.

$$V_{CB} = 2 \times V_{CC} - V_{D1} - V_{DS(\text{ON})} + V_F < 35 \text{ [V]}$$

$$V_{CC} < \frac{35 + V_{D1} + V_{DS(\text{ON})} - V_F}{2} \text{ [V]}$$

$$< 17 \text{ [V]}$$

##### (2) Value setting for bootstrap capacitor

The bootstrap capacitor is capacitance-coupled with the n-channel MOSFET source-side at its turn-on time to increase the CB terminal voltage over the  $V_{CC}$ . At this time, the bootstrap capacitor is discharged by the n-channel MOSFET gate drive current. If the capacitance value of the bootstrap capacitor is set at too low value, it causes the efficiency decrease due to increase in switching loss.

Therefore, set the capacitance at a sufficiently high value compared with the n-channel MOSFET gate input capacitance.

$$C_B \gg C_{iss}$$

Study with the actual mounting board and set the optimum value.

##### (3) CB terminal connection when the booster circuit is used

In the case of using the step-up type DC-DC converter control, the bootstrap circuit is not required since the n-channel MOSFET source side is grounded. Therefore, use it by short-circuiting the CB terminal (pin 14) to the  $V_{CC}$  terminal (pin 15).

For that reason, the operating supply voltage range is 3.6 V to 34 V in the case of using the step-up circuit type.

■ Application Circuit Examples

- Inverter control for liquid crystal backlight

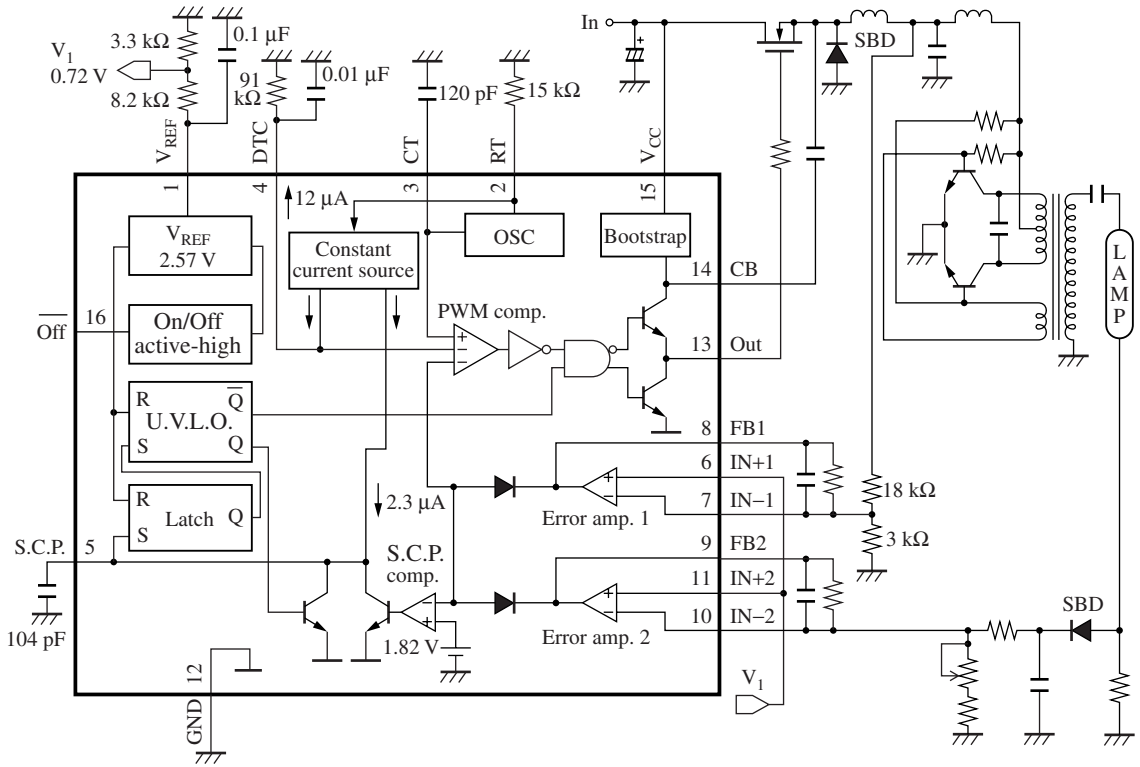

- DC-DC converter control (step-up circuit example)

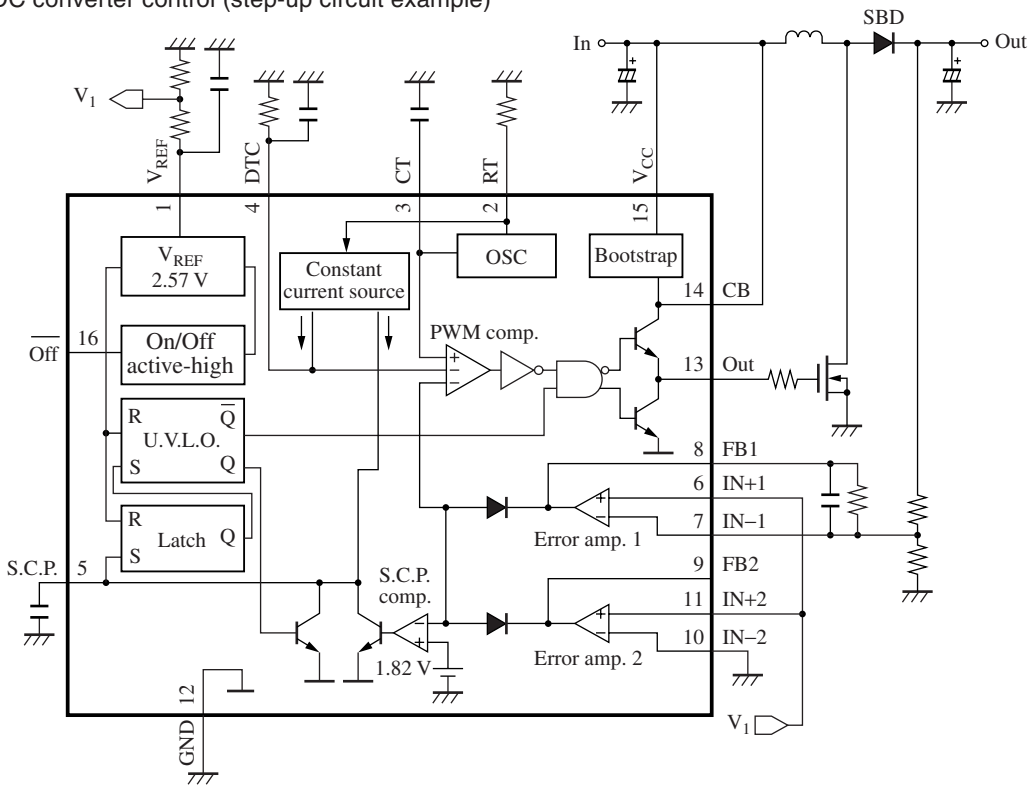

## ■ New Package Dimensions (Unit: mm)

- SOP016-P-0225E (Lead-free package)

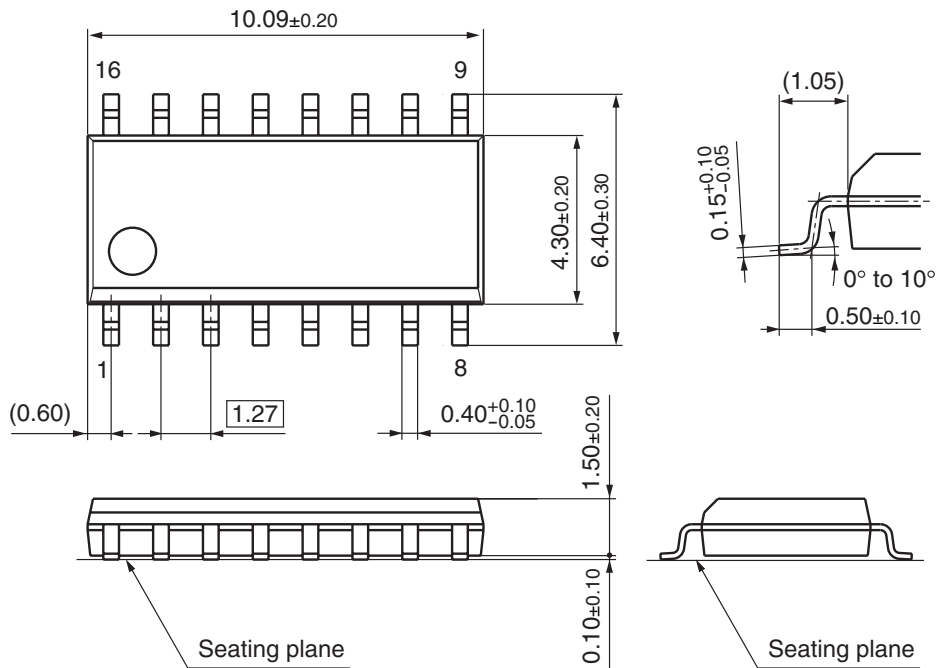

## Request for your special attention and precautions in using the technical information and semiconductors described in this material

- (1) An export permit needs to be obtained from the competent authorities of the Japanese Government if any of the products or technologies described in this material and controlled under the "Foreign Exchange and Foreign Trade Law" is to be exported or taken out of Japan.
- (2) The technical information described in this material is limited to showing representative characteristics and applied circuits examples of the products. It neither warrants non-infringement of intellectual property right or any other rights owned by our company or a third party, nor grants any license.
- (3) We are not liable for the infringement of rights owned by a third party arising out of the use of the product or technologies as described in this material.
- (4) The products described in this material are intended to be used for standard applications or general electronic equipment (such as office equipment, communications equipment, measuring instruments and household appliances).  
Consult our sales staff in advance for information on the following applications:
  - Special applications (such as for airplanes, aerospace, automobiles, traffic control equipment, combustion equipment, life support systems and safety devices) in which exceptional quality and reliability are required, or if the failure or malfunction of the products may directly jeopardize life or harm the human body.
  - Any applications other than the standard applications intended.
- (5) The products and product specifications described in this material are subject to change without notice for modification and/or improvement. At the final stage of your design, purchasing, or use of the products, therefore, ask for the most up-to-date Product Standards in advance to make sure that the latest specifications satisfy your requirements.
- (6) When designing your equipment, comply with the guaranteed values, in particular those of maximum rating, the range of operating power supply voltage, and heat radiation characteristics. Otherwise, we will not be liable for any defect which may arise later in your equipment.  
Even when the products are used within the guaranteed values, take into the consideration of incidence of break down and failure mode, possible to occur to semiconductor products. Measures on the systems such as redundant design, arresting the spread of fire or preventing glitch are recommended in order to prevent physical injury, fire, social damages, for example, by using the products.
- (7) When using products for which damp-proof packing is required, observe the conditions (including shelf life and amount of time let standing of unsealed items) agreed upon when specification sheets are individually exchanged.
- (8) This material may be not reprinted or reproduced whether wholly or partially, without the prior written permission of Matsushita Electric Industrial Co., Ltd.



LittleDiode supplies new, hard to find or obsolete electronic components and semiconductors all over the world.

With over two million different components listed you are sure to find the part you need.

Feel free to visit us today at our online store:

[LittleDiode.com](http://LittleDiode.com)

Looking forward to providing you with the best possible service.