

# AN8015SH

## Single-channel step-down, step-up, or inverting use DC-DC converter control IC

### Overview

The AN8015SH is a single-channel DC-DC converter control IC using the PWM method.

This IC can provide any one output type from among step-down, step-up and inverting output.

Its operating supply voltage range is wide and its consumption current is small. In addition, since it uses the 10-pin surface mounting type package with 0.5 mm pitch, it is suitable for highly efficient miniature portable power supply, especially for a negative output power supply.

### Features

- Wide operating supply voltage range (3.6 V to 34 V)
- Small consumption current (1.8 mA typical)
- Converter control in a wide output frequency range is possible (2 kHz to 500 kHz).
- Built-in timer latch short-circuit protection circuit (charge current 1.1  $\mu$ A typical)
- Incorporating the under-voltage lock-out (U.V.L.O.) circuit
- Incorporating a high precision reference voltage circuit (2.46 V (allowance:  $\pm 3\%$ ))
- Output block is open-collector (darlington) type.
- High absolute maximum rating of output current (100 mA)
- Maximum duty ratio is fixed and has small sample-to-sample variations (90%  $\pm 5\%$ ).

### Applications

- LCD displays, digital still cameras, and PDAs

### Block Diagram

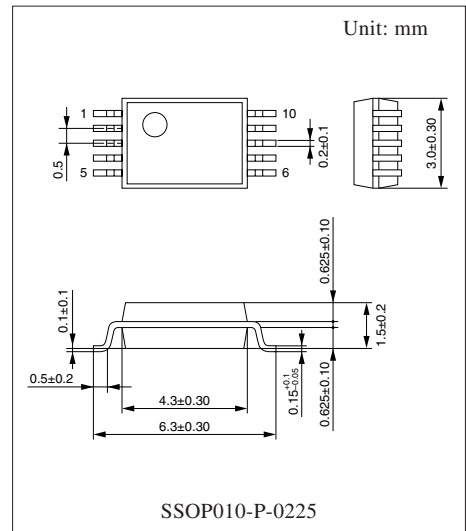
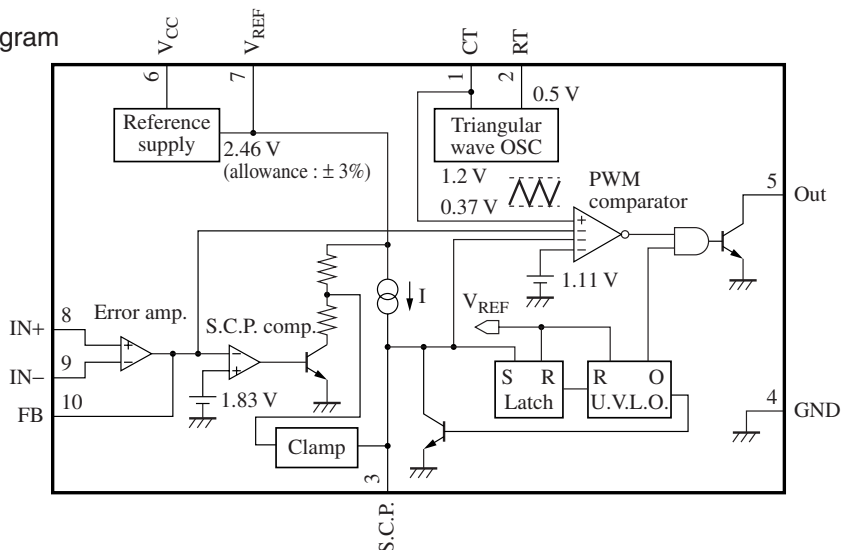

Note) The package of this product will be changed to lead-free type (SSOP010-P-0225A). See the new package dimensions section later of this datasheet.

### ■ Pin Descriptions

Pin No.	Symbol	Description
1	CT	Pin for connecting oscillator timing capacitor
2	RT	Pin for connecting oscillator timing resistor
3	S.C.P.	Pin for connecting the time constant setting capacitor for short-circuit protection
4	GND	Grounding pin
5	Out	Open collector type output pin
6	V <sub>CC</sub>	Power supply voltage application pin
7	V <sub>REF</sub>	Reference voltage output pin
8	IN+	Error amplifier noninverted input pin
9	IN-	Error amplifier inverted input pin
10	FB	Output pin of error amplifier

### ■ Absolute Maximum Ratings

Parameter	Symbol	Rating	Unit
Supply voltage	V <sub>CC</sub>	35	V
IN- terminal allowable application voltage	V <sub>IN-</sub>	- 0.3 to V <sub>REF</sub>	V
IN+ terminal allowable application voltage	V <sub>IN+</sub>	- 0.3 to V <sub>REF</sub>	V
Output terminal allowable application voltage	V <sub>OUT</sub>	35	V
Collector output current	I <sub>OUT</sub>	100	mA
Power dissipation *	P <sub>D</sub>	154	mW
Operating ambient temperature *	T <sub>opr</sub>	-30 to +85	°C
Storage temperature *	T <sub>stg</sub>	-55 to +150	°C

Note) \*: Expect for the power dissipation, operating ambient temperature and storage temperature, all ratings are for T<sub>a</sub> = 25°C.

### ■ Recommended Operating Range

Parameter	Symbol	Range	Unit
Error amplifier input voltage	V <sub>IN</sub>	- 0.1 to 0.8	V
Collector output voltage	V <sub>OUT</sub>	34 (maximum)	V
Collector output current	I <sub>OUT</sub>	50 (maximum)	mA
Timing capacitance	C <sub>T</sub>	100 to 27 000	pF
Timing resistance	R <sub>T</sub>	5.6 to 15	kΩ
Oscillation frequency	f <sub>OUT</sub>	2 to 500	kHz
Reference voltage output current	I <sub>RE</sub>	-3 to 0	mA
Soft start short-circuit protection time constant setting capacitance	C <sub>SCP</sub>	1 000 (minimum)	pF

**■ Electrical Characteristics at  $V_{CC} = 12\text{ V}$ ,  $R_T = 15\ \Omega$ ,  $C_T = 200\ \text{pF}$ ,  $T_a = 25^\circ\text{C}$** 

Parameter	Symbol	Conditions	Min	Typ	Max	Unit
<b>Reference voltage block</b>						
Reference voltage	$V_{REF}$	$I_{REF} = -1\ \text{mA}$	2.386	2.46	2.534	V
Input regulation with input fluctuation	Line	$V_{CC} = 3.6\ \text{V}$ to $34\ \text{V}$ , $I_{REF} = -1\ \text{mA}$	—	5	20	mV
Input regulation with input fluctuation 2	Line2	$V_{CC} = 3.6\ \text{V}$ to $20\ \text{V}$	—	—	10	mV
Load regulation	Load	$I_{REF} = -0.1\ \text{mA}$ to $-1\ \text{mA}$	—	2	10	mV
Output voltage temperature characteristics 1	$V_{TC1}$	$T_a = -30^\circ\text{C}$ to $+25^\circ\text{C}$	—	$\pm 0.5$	—	%
Output voltage temperature characteristics 2	$V_{TC2}$	$T_a = 25^\circ\text{C}$ to $85^\circ\text{C}$	—	$\pm 0.5$	—	%
Reference short-circuit current	$I_{RS}$		—	-20	—	mA
<b>U.V.L.O. block</b>						
Circuit operation start voltage	$V_{UON}$		2.8	3.1	3.4	V
Hysteresis width	$V_{HYS}$		100	200	300	mV
<b>Error amplifier block</b>						
Input offset voltage	$V_{IO}$		-6	—	6	mV
Input bias current	$I_B$		-500	-25	—	nA
Common-mode input voltage range	$V_{ICR}$		-0.1	—	0.8	V
High-level output voltage	$V_{EH}$		$V_{REF}-0.3$	$V_{REF}-0.1$	—	V
Low-level output voltage	$V_{EL}$		—	0.1	0.3	V
Output sink current	$I_{SINK}$	$V_{FB} = 0.8\ \text{V}$	—	8	—	mA
Output source current	$I_{SOURCE}$	$V_{FB} = 0.8\ \text{V}$	—	-120	—	$\mu\text{A}$
Open-loop gain	$A_V$		—	70	—	dB
Common-mode ripple rejection ratio	CMRR		—	50	—	dB
<b>Output block</b>						
Oscillation frequency	$f_{OUT}$	$R_T = 15\ \text{k}\Omega$ , $C_T = 200\ \text{pF}$	175	195	215	kHz
Maximum duty ratio	$D_{U_{max}}$	$R_T = 15\ \text{k}\Omega$ , $C_T = 200\ \text{pF}$	85	90	95	%
Output saturation voltage	$V_{OL}$	$I_O = 50\ \text{mA}$ , $R_T = 15\ \text{k}\Omega$	—	0.9	1.2	V
Output leak current	$I_{LEAK}$	$V_{CC} = 34\ \text{V}$ , when output transistor is off	—	—	10	$\mu\text{A}$
RT terminal voltage	$V_{RT}$		—	0.5	—	V
Maximum oscillation frequency	$f_{OUT(max)}$	$R_T = 5.6\ \text{k}\Omega$ , $C_T = 150\ \text{pF}$	—	500	—	kHz
Frequency supply voltage characteristics	$f_{dV}$	$f_{OUT} = 200\ \text{kHz}$ , $V_{CC} = 3.6\ \text{V}$ to $34\ \text{V}$	—	$\pm 2$	—	%
Frequency temperature characteristics 1	$f_{dT1}$	$f_{OUT} = 200\ \text{kHz}$ , $T_a = -30^\circ\text{C}$ to $+25^\circ\text{C}$	—	$\pm 3$	—	%
Frequency temperature characteristics 2	$f_{dT2}$	$f_{OUT} = 200\ \text{kHz}$ , $T_a = 25^\circ\text{C}$ to $85^\circ\text{C}$	—	$\pm 3$	—	%

**■ Electrical Characteristics at  $V_{CC} = 12\text{ V}$ ,  $R_T = 15\text{ k}\Omega$ ,  $C_T = 200\text{ pF}$ ,  $T_a = 25^\circ\text{C}$  (continued)**

Parameter	Symbol	Conditions	Min	Typ	Max	Unit
<b>Short-circuit protection circuit block</b>						
Input threshold voltage	$V_{THPC}$		1.73	1.83	1.93	V
Input standby voltage	$V_{STBY}$		1.15	1.25	1.35	V
Input latch voltage	$V_{IN}$		—	30	120	mV
Charge current	$I_{CHG}$	$V_{SCP} = 0\text{ V}$	-1.32	-1.1	-0.88	$\mu\text{A}$
Comparator threshold voltage	$V_{THL}$		—	1.83	—	V
<b>Whole device</b>						
Total consumption current	$I_{CC}$	$R_T = 15\text{ k}\Omega$	—	1.8	2.8	mA
Total consumption current 2	$I_{CC2}$	$R_T = 5.6\text{ k}\Omega$ , $C_T = 150\text{ pF}$	—	2.5	—	mA

**■ Terminal Equivalent Circuits**

Pin No.	Equivalent circuit	Description	I/O
1		<b>CT:</b> The terminal used for connecting a timing capacitor to set oscillation frequency. Use a capacitance value within the range of 100 pF to 27 000 pF. Use an oscillation frequency in the range of 2 kHz to 500 kHz.	O
2		<b>RT:</b> The terminal used for connecting a timing resistor to set oscillation frequency. Use a resistance value within the range of 5.6 k $\Omega$ to 15 k $\Omega$ . The terminal voltage is 0.5 V typ.	I
3		<b>S.C.P.:</b> The terminal used for connecting a capacitor to set the time constant of soft start and timer latch short-circuit protection circuit. Use a capacitance value in the range of more than 1 000 pF. The charge current is about 1.1 mA at $R_T = 15\text{ k}\Omega$ $I_{CHG} = \frac{V_{RT}}{R_T} \times \frac{1}{30} [\text{A}]$	O
4		<b>GND:</b> Grounding terminal	—

■ Terminal Equivalent Circuits (continued)

Pin No.	Equivalent circuit	Description	I/O
5		<p>Out:</p> <p>Open-collector type (darlington) output terminal. The absolute maximum rating of output current is 100 mA. Use with a steady-state output current under 50 mA.</p>	O
6		<p>V<sub>CC</sub>:</p> <p>The terminal for applying supply voltage. Use with a operating supply voltage within the range of 3.6 V to 34 V.</p>	—
7		<p>V<sub>REF</sub>:</p> <p>The output terminal for the reference voltage (2.46 V). Use with a load current -3 mA or under. This terminal is incorporating the short-circuit protection circuit, and the short-circuit current is about -20 mA. Use the V<sub>REF</sub> for the reference input setting of the error amplifier.</p>	O
8		<p>IN+:</p> <p>The noninverted input terminal of the error amplifier. For common-mode input, use in the range of -0.1 V to +0.8 V.</p>	I
9		<p>IN-:</p> <p>The inverted input terminal of the error amplifier. For common-mode input, use in the range of -0.1 V to +0.8 V.</p>	I
10		<p>FB:</p> <p>The output terminal of the error amplifier. The source current is about -120 μA, and the sink current is about 8 mA. Correct the frequency characteristics of the gain and the phase by connecting a resistor and a capacitor between this terminal and IN- terminal.</p>	O

■ Application Notes

[1] Main characteristics

Reference voltage temperature characteristics

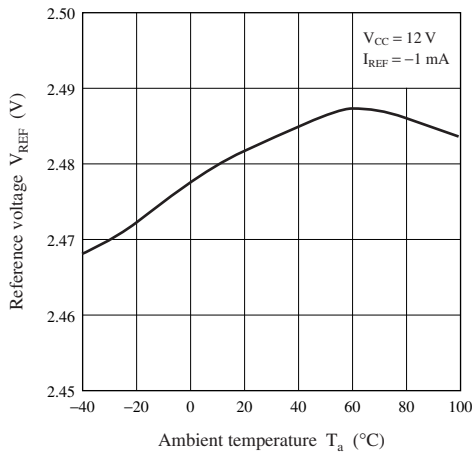

Maximum duty ratio temperature characteristics

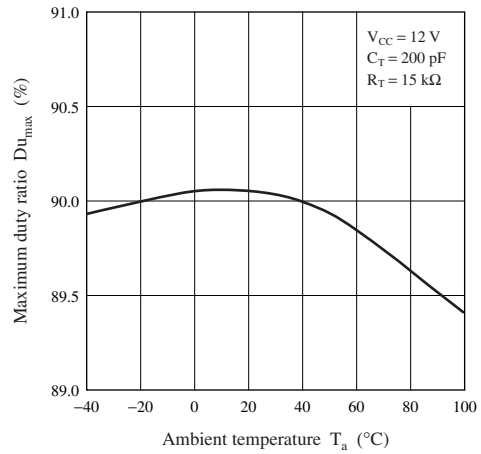

Oscillation frequency temperature characteristics

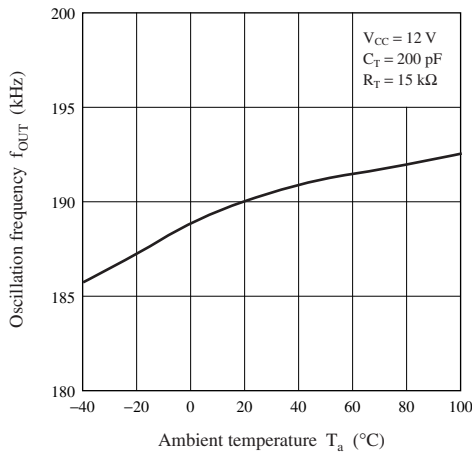

Timing capacitance — Oscillation frequency

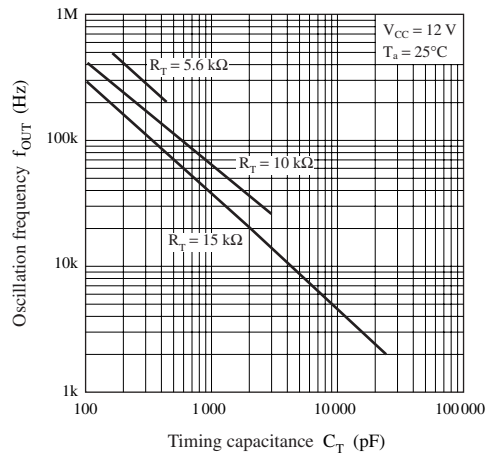

Maximum duty ratio — Oscillation frequency

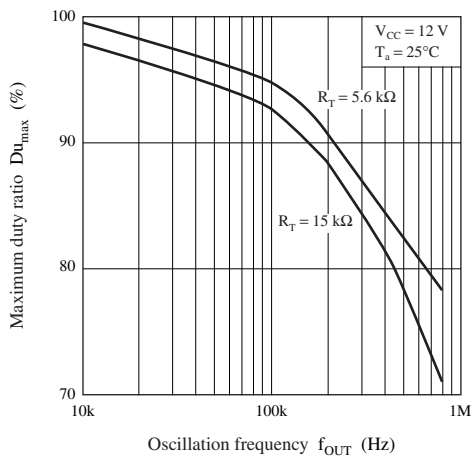

Oscillation frequency — Triangular wave maximum amplitude voltage

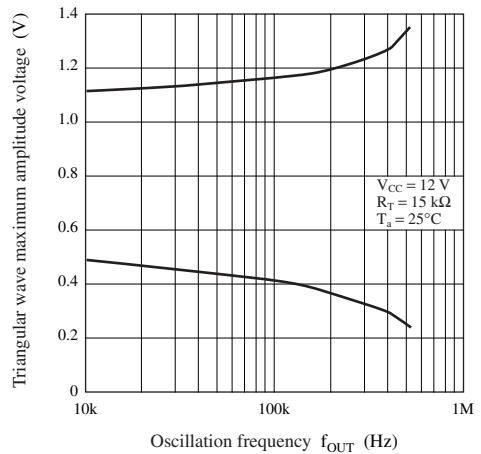

■ Application Notes (continued)

[1] Main characteristics (continued)

Supply voltage — Reference voltage

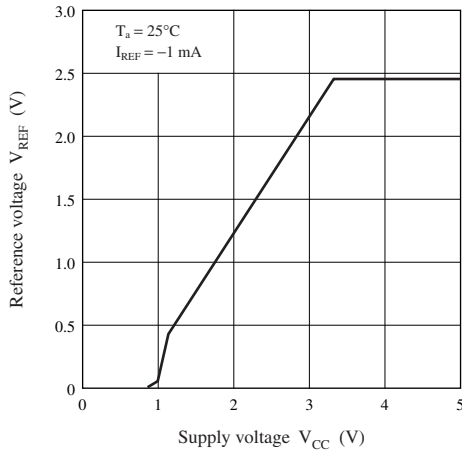

Supply voltage — Total consumption current

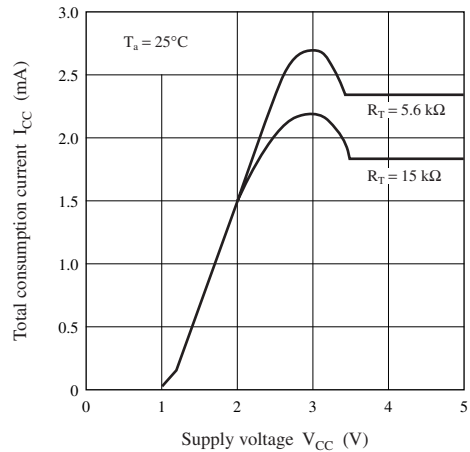

Reference voltage line regulation

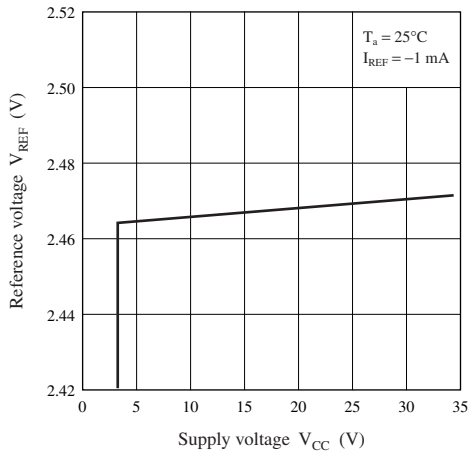

Total consumption current line regulation

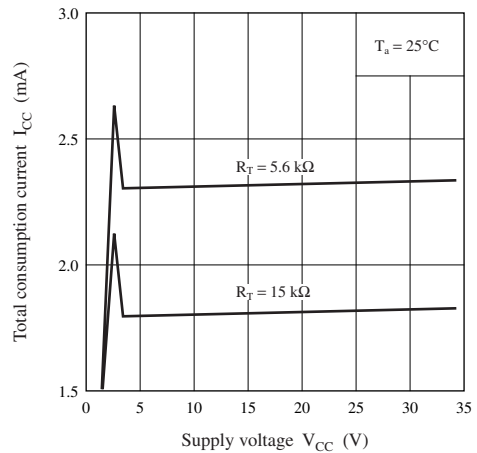

Timing resistance — Total consumption current

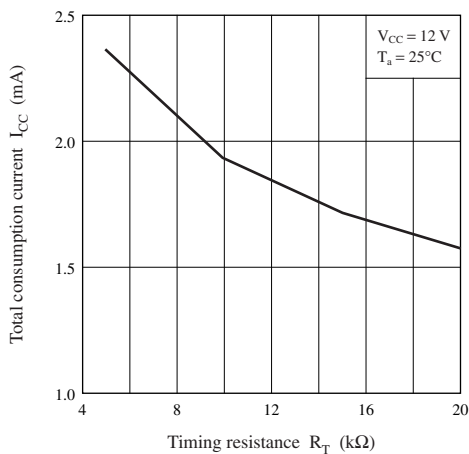

Timing resistance — Output saturation voltage

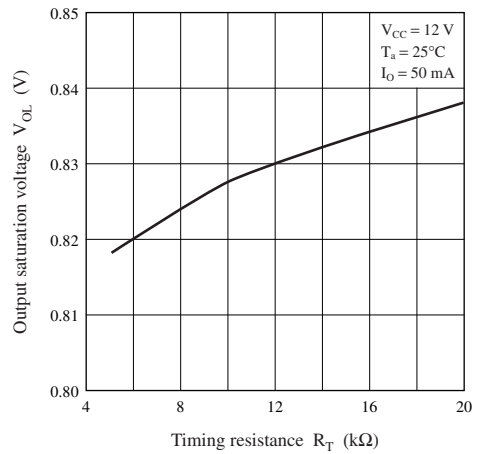

■ Application Notes (continued)

[2] Timing chart

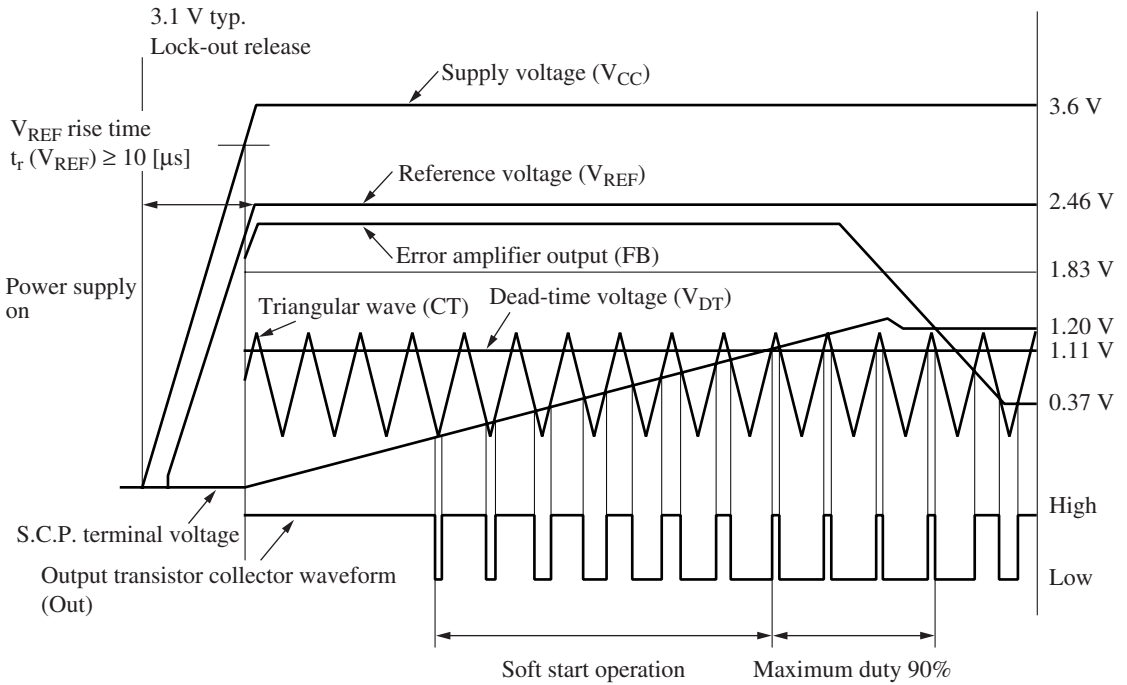

Figure 1. PWM comparator operation waveform

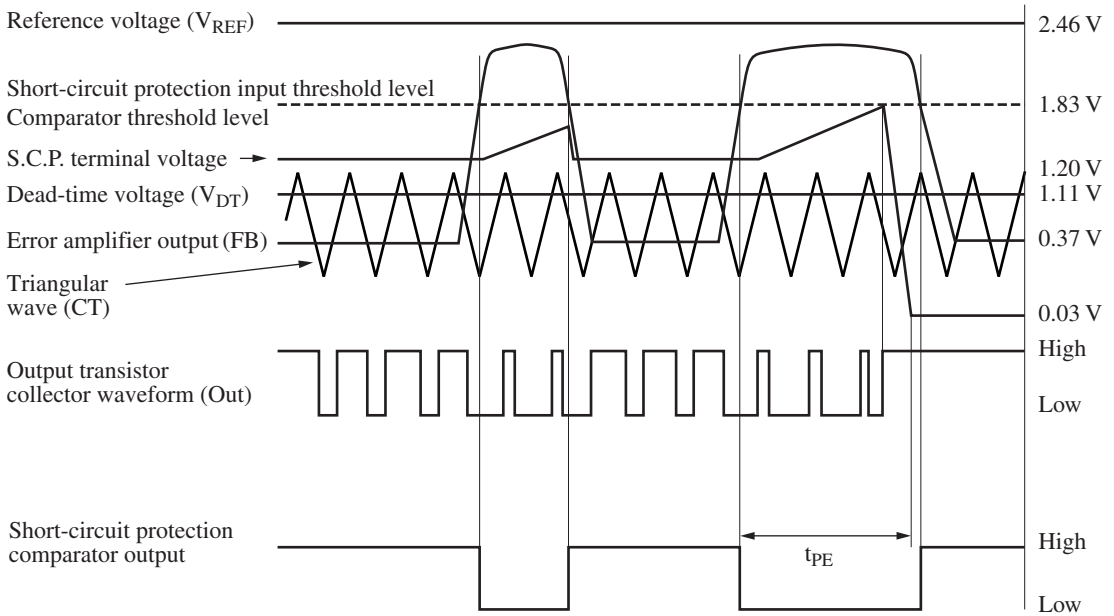

Figure 2. Short-circuit protection operation waveform

■ Application Notes (continued)

[3] Function descriptions

1. Reference voltage block

This block is composed of the band gap circuit, and outputs the temperature compensated 2.46 V reference voltage to the  $V_{REF}$  terminal (pin 7). The reference voltage is stabilized when the supply voltage is 3.6 V or higher, and used as the operating power supply for the IC inside. It is possible to take out a load current of up to  $-3\text{ mA}$ .

Also, an overcurrent protection circuit is built in for the load, thereby protecting the IC from destruction when  $V_{REF}$  terminal is short circuited.

2. Triangular wave oscillation block

The triangular wave which swings from the highest wave of approximately 1.4 V to the lowest wave of approximately 0.37 V will be generated by connecting a timing capacitor and a resistor to the CT terminal (pin 1) and RT terminal (pin 2) respectively. The oscillation frequency can be freely decided by the value of  $C_T$  and  $R_T$  connected externally.

The triangular wave is connected with the inverted input of PWM comparator of the IC inside.

3. Error amplifier block

This block detects the output voltage of DC-DC converter by the pnp transistor input type error amplifier, and inputs the amplified signal to the PWM comparator.

The common-mode input voltage range is  $-0.1\text{ V}$  to  $0.8\text{ V}$ , and is a voltage obtained by dividing the reference voltage with resistors.

Also, it is possible to perform the gain setting and the phase compensation arbitrarily by inserting the feedback resistor and capacitor between the error amplifier output terminal (pin 10) and the inverted input terminal (pin 9).

The output voltage  $V_{OUT}$ , if positive, is obtained by connecting the resistor-divided reference voltage to the noninverted input terminal as shown in figure 3. 1), and the output voltage  $V_{OUT}$ , if negative, is obtained by connecting to the inverted input terminal as shown in figure 3. 2). The output voltages in each of these cases are given in the following equations.

$$V_{OUT} = V_{IN+} \times \frac{R1 + R2}{R2}$$

$$V_{IN+} = V_{REF} \times \frac{R4}{R3 + R4}$$

$$V_{OUT} = -(V_{REF} - V_{IN-}) \times \frac{R3 + R4}{R3} + V_{REF}$$

$$V_{IN-} = V_{REF} \times \frac{R2}{R1 + R2}$$

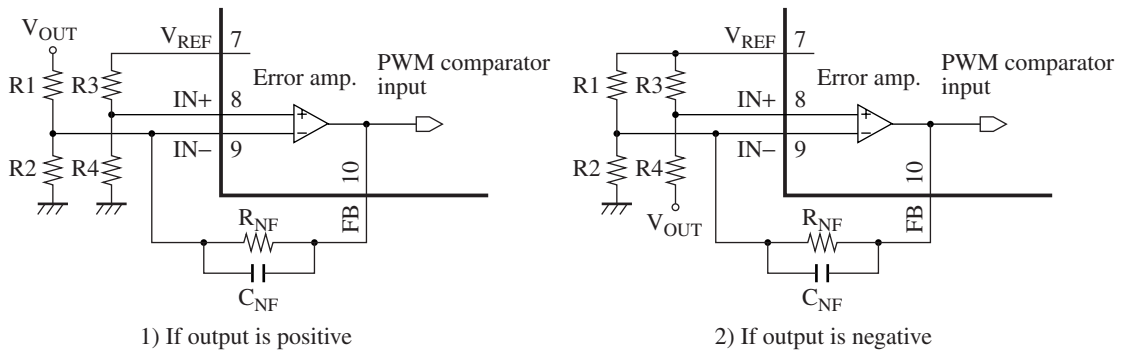

Figure 3. Connection method of error amplifier

4. Timer latch short-circuit protection circuit

This circuit protects the external main switching devices, flywheel diodes, and choke coils, etc. from destruction or deterioration if overload or short-circuit of power supply output lasts for a certain time.

The timer latch short-circuit protection circuit detects the output level of the error amplifier. When the output voltage of DC-DC converter drops and the output level of error amplifiers exceeds 1.85 V, the low-level output is given and the timer circuit is actuated to start the charge of the external protection enable capacitor.

If the output of the error amplifier does not return to a normal voltage range by the time when the voltage of this capacitor reaches 1.83 V, it sets the latch circuit, cuts off the output drive transistor, and sets the dead-time at 100%.

## ■ Application Notes (continued)

### [3] Function descriptions (continued)

#### 5. Low input voltage malfunction prevention circuit (U.V.L.O.)

This circuit protects the system from destruction or deterioration due to control malfunction when the supply voltage is low in the transient state of power on/off.

The low input voltage malfunction prevention circuit detects the internal reference voltage which changes according to the supply voltage level. Until the supply voltage reaches 3.1 V during its rise time, it cuts off the output drive transistor, sets the dead-time at 100% and holds the S.C.P. terminal (pin 3) to low level. During the fall time of the power supply voltage, it has hysteresis width of 200 mV and operates 2.9 V or less.

#### 6. PWM comparator block

The PWM comparator controls the on-period of the output pulse according to the input voltage. It turns on the output transistor during the period when the triangular wave of CT terminal (pin 1) of noninverted input is lower than any one of the following voltages : the voltage of the error amplifier output (pin 10) of the inverted input, S.C.P. terminal (pin 3), and the voltage for dead-time which is fixed inside the IC.

The S.C.P. terminal voltage is kept at 1.25 V in the state in which DC-DC converter output is stabilized. However, when the power supply is turned on, the soft start is activated, which gradually extends on-period according to the time constant determined by the capacitance of externally attached capacitor and the charge current. The maximum duty ratio is fixed at approximately 90% by the voltage for dead-time.

#### 7. Output block

The output drive transistor is of open-collector type output connected in darlington circuit of emitter common GND. The breakdown voltage of collector output terminal (pin 5) is 34 V and it is possible to obtain up to 100 mA output current.

### [4] Triangular wave oscillation circuit

#### 1. Oscillation frequency setting method

The waveform of triangular wave oscillation is obtained by charging and discharging of the constant current  $I_O$  from the external timing capacitor  $C_T$  which is connected to CT terminal (pin 1). The constant current is set by the externally attached timing resistor  $R_T$ .

The peak value of the wave  $V_{CTH}$  and the trough value of the wave  $V_{CTL}$  are fixed at approximately 1.4 V typical and 0.37 V typical respectively.

The oscillation frequency  $f_{OSC}$  is obtained by the following formula;

$$f_{OSC} = \frac{1}{t_1 + t_2} = \frac{I_O}{2 \times C_T \times (V_{CTH} - V_{CTL})}$$

$$\text{whereas } I_O = 2 \times \frac{V_{RT}}{R_T} = 2 \times \frac{0.5}{R_T}$$

$$\text{because } V_{CTH} - V_{CTL} = 0.83 \text{ V}$$

$$f_{OSC} = \frac{1}{1.66 \times C_T \times R_T}$$

The output frequency  $f_{OUT}$  is equal to  $f_{OSC}$  since it is PWM-controlled.

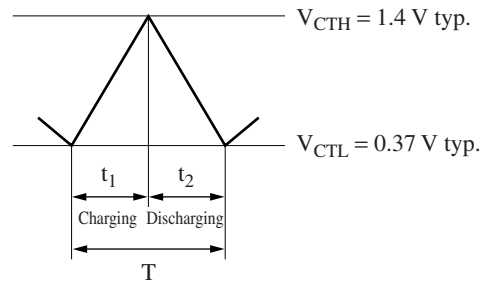

Figure 4. Triangular wave oscillation waveform

■ Application Notes (continued)

[4] Triangular wave oscillation circuit (continued)

2. Usage notes

This IC uses the constant current given by the timing resistor  $R_T$  as the bias current of the triangular oscillation block and the PWM comparator for consumption current reduction. The total consumption current is approximately 1.8 mA (typical) when  $R_T$  is 15 k $\Omega$ , and it increases to approximately 2.5 mA (typical) when  $R_T$  is 5.6 k $\Omega$ . In order to obtain the steady-state output current of 100 mA at the open collector output, it is necessary to set  $R_T$  value to 15 k $\Omega$  or smaller.

It is possible to use the circuit in the recommended operating range of 2 kHz to 500 kHz of the oscillation frequency. However, the timing resistor  $R_T$  versus the oscillation frequency should be set within the recommended range shown in figure 5. Also, refer to the "Applications Notes, [1] Main characteristics, Timing capacitance — Oscillation frequency" for setting the timing capacitance.

For a high frequency use, the overshoot and undershoot amounts increase due to operation delay of the triangular oscillation comparator, and the maximum duty ratio drops. This effect can be alleviated by speeding up through the reduction of the resistor  $R_T$  and increase in the circuit current.

Note that this IC can not be used as an IC for slave when the several ICs are operated in parallel synchronous mode.

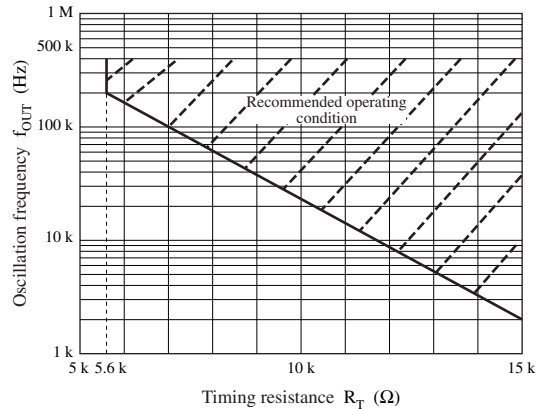

Figure 5. Timing resistance recommended condition

[5] Time constant setting method for short-circuit protection circuit with joint-use of soft start/timer latch type

The constructional block diagram of protection latch circuit is shown in figure 6. The comparator for short-circuit protection compares the output of error amplifier  $V_{FB}$  with the reference voltage of 1.85 V at all the time.

When the load conditions of DC-DC converter output is stabilized, there is no fluctuation of error amplifier output and the short-circuit protection comparator also keeps the balance. At this moment, the output transistor Q1 is in the conductive state and the S.C.P. terminal is hold to approximately 1.25 V through the clamp circuit.

When the load conditions suddenly change, and high-level signal (1.85 V or higher) is input from the error amplifier to the noninverted input of the short-circuit protection comparator, the short-circuit protection comparator outputs the low-level signal. Since this signal cuts off the output transistor Q1, the S.C.P. terminal voltage  $V_{PE}$  is released, and the externally connected capacitor  $C_S$  starts charging according to the following equation:

$$V_{PE} = V_{STBY} + I_{CHG} \times \frac{t_{PE}}{C_S} \text{ [V]}$$

$$1.83 \text{ V} = 1.25 \text{ V} + I_{CHG} \times \frac{t_{PE}}{C_S}$$

$$C_S = I_{CHG} \times \frac{t_{PE}}{0.58} \text{ [F]}$$

$I_{CHG}$  is the constant current determined by the oscillation timing resistor  $R_T$  and its dispersion and fluctuation with temperature are small.  $I_{CHO}$  is expressed in the following equation:

$$I_{CHG} = \frac{V_{RT}}{R_T} \times \frac{1}{30} \text{ [A]}$$

$V_{RT}$  is approximately 0.5 V and  $I_{CHO}$  becomes approximately 1.1  $\mu\text{A}$  when  $R_T$  = 15 k $\Omega$ .

## ■ Application Notes (continued)

### [5] Time constant setting method for short-circuit protection circuit with joint-use of soft start/timer latch type (continued)

When the external capacitor  $C_S$  has been charged up to approximately 1.83 V, it sets the latch circuit, cuts off the output drive transistor by enabling the low input voltage malfunction prevention circuit, and sets the dead-time at 100%.

The low input voltage malfunction prevention circuit is once enabled, the S.C.P. terminal voltage is discharged to approximately 30 mV but the latch circuit is not reset unless the power is turned off.

The S.C.P. terminal voltage is inputted to the PWM comparator, and the soft start is actuated when the power turns on. However, since at the beginning of power on, the error amplifier output is high level, and  $V_{PE}$  of S.C.P. terminal voltage is released and charging begins; the external capacitor should be set so that the output voltage of DC-DC convertor starts to rise before the latching circuit is set. The charging equation is as same as the above. The soft start time  $t_{SS}$  until the input standby voltage  $V_{STBY}$  becomes 1.25 V is given in the following equations:

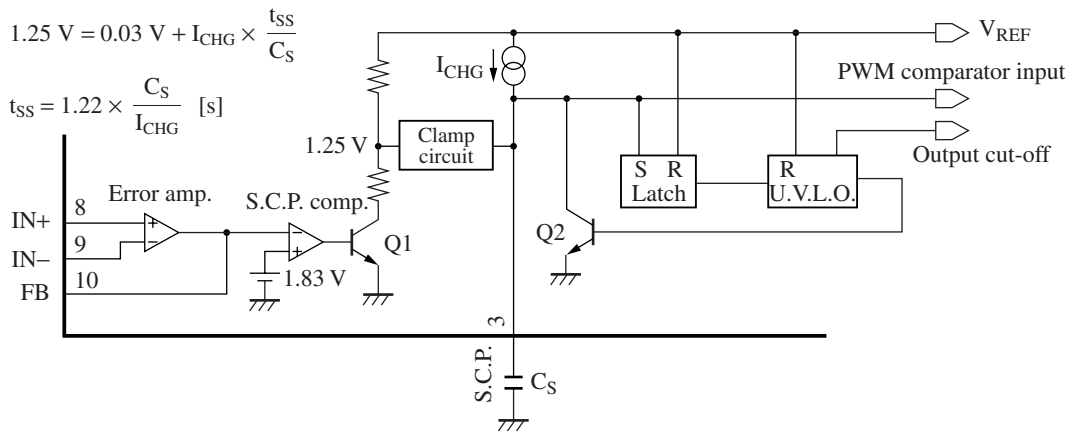
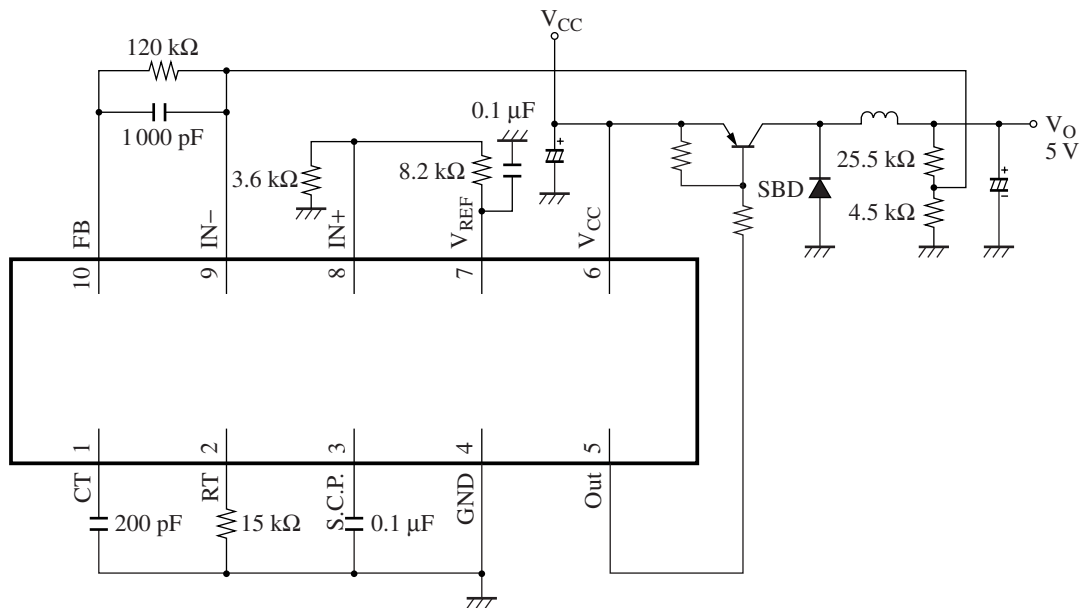

Figure 6. Short-circuit protection circuit

■ Application Circuit Examples

1. Chopper method step-down type



2. Chopper method inverting type

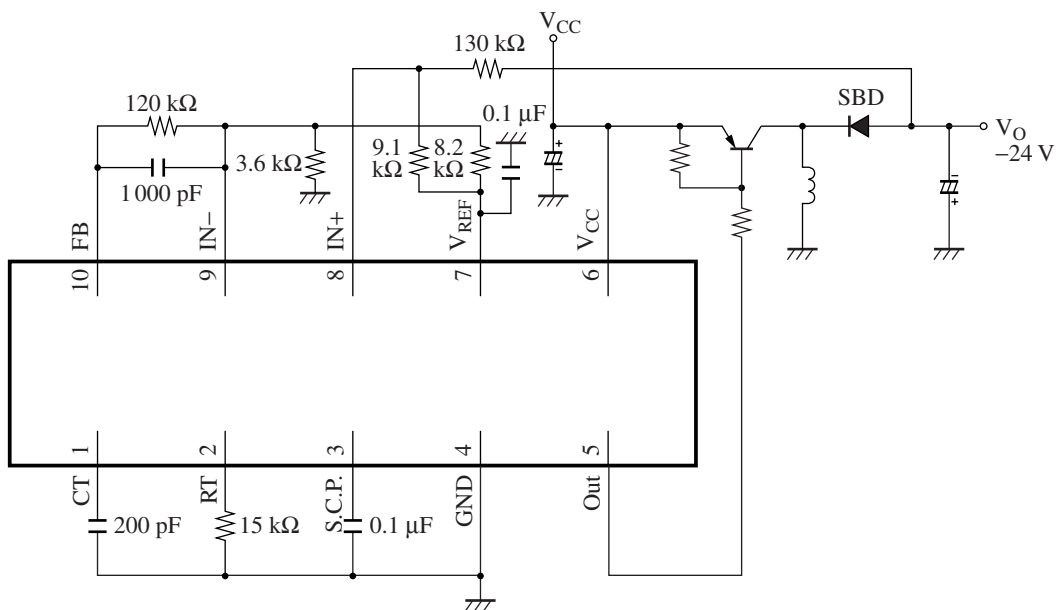

### ■ Application Circuit Examples (continued)

#### 3. On/off circuit example

##### 1) Method to cut $V_{CC}$ line

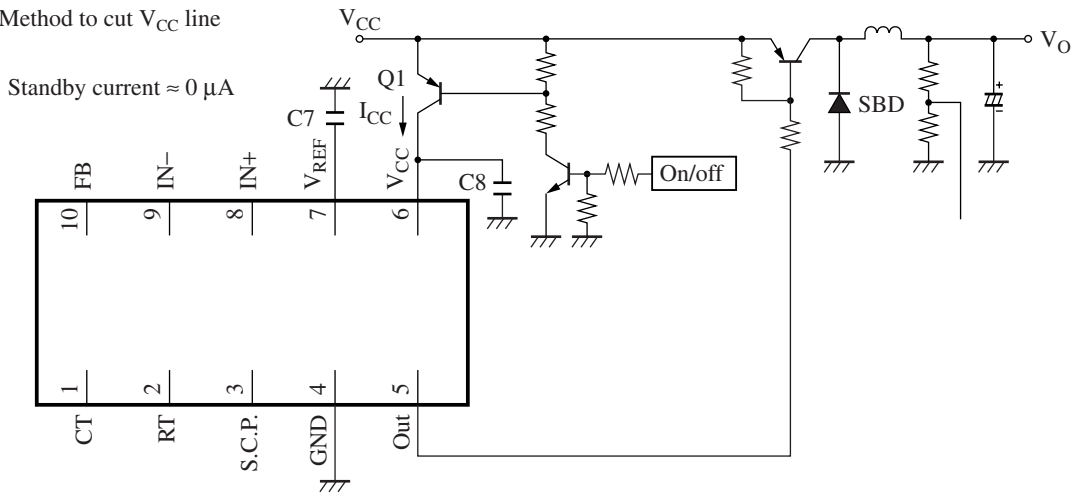

##### 2) Method to cut S.C.P. line

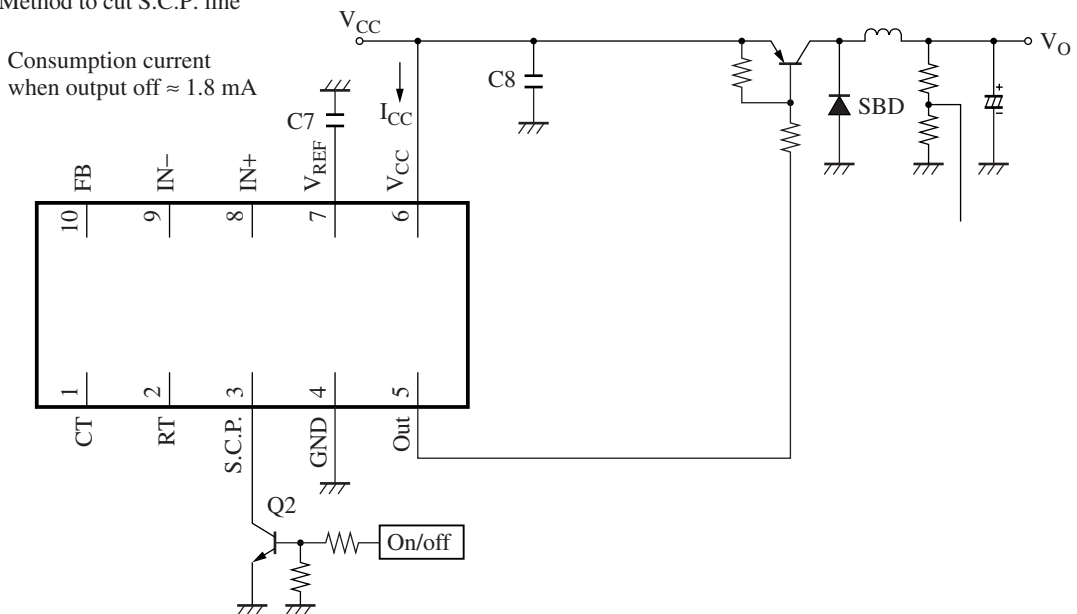

#### 4. Using method

Since the on/off circuit is not incorporated in this IC, it is required to add on/off circuit externally to provide a standby function.

When the switch (Q1) is inserted between the  $V_{CC}$  line and the  $V_{CC}$  pin of the IC (pin 6) as shown in 3. 1), the standby current is suppressed to 0. When the output is turned off by decreasing the S.C.P. terminal voltage below the lower limit of the triangular wave (0.37 V typical) as shown in 3. 2), the consumption current does not decrease because the IC is operating.

#### 5. Usage notes

The rise time of the  $V_{CC}$  becomes sharp especially in the case of 3. 1). At that time, there is a case that the internal latch circuit of the IC is set so that the circuit fails to start. Adjust C7 or C8 so that the rise time for  $V_{REF}$  pin (pin 7) becomes 10 ms or longer.

■ New Package Dimensions (Unit: mm)

- SSOP010-P-0225A (Lead-free package)

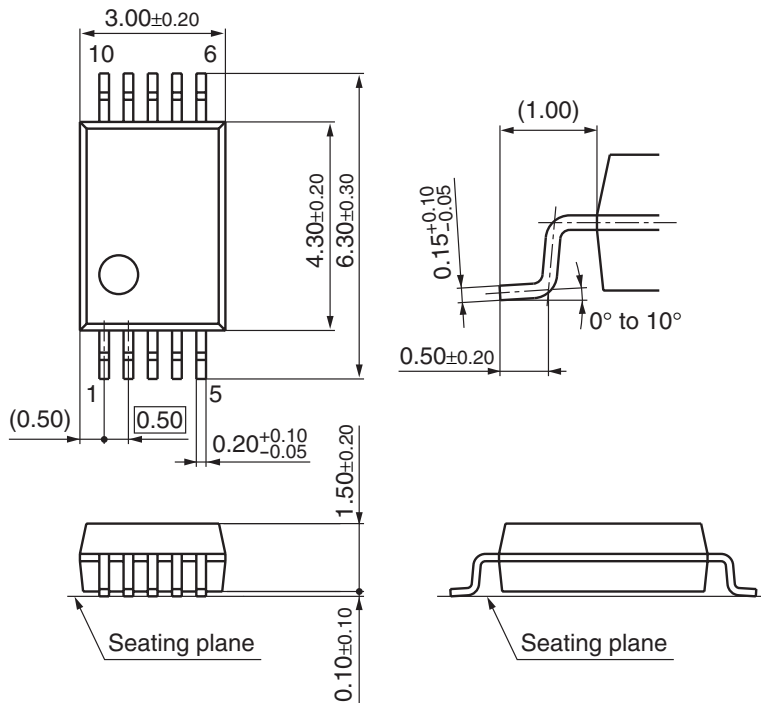

## Request for your special attention and precautions in using the technical information and semiconductors described in this material

- (1) An export permit needs to be obtained from the competent authorities of the Japanese Government if any of the products or technologies described in this material and controlled under the "Foreign Exchange and Foreign Trade Law" is to be exported or taken out of Japan.
- (2) The technical information described in this material is limited to showing representative characteristics and applied circuits examples of the products. It neither warrants non-infringement of intellectual property right or any other rights owned by our company or a third party, nor grants any license.
- (3) We are not liable for the infringement of rights owned by a third party arising out of the use of the product or technologies as described in this material.
- (4) The products described in this material are intended to be used for standard applications or general electronic equipment (such as office equipment, communications equipment, measuring instruments and household appliances).  
Consult our sales staff in advance for information on the following applications:
  - Special applications (such as for airplanes, aerospace, automobiles, traffic control equipment, combustion equipment, life support systems and safety devices) in which exceptional quality and reliability are required, or if the failure or malfunction of the products may directly jeopardize life or harm the human body.
  - Any applications other than the standard applications intended.
- (5) The products and product specifications described in this material are subject to change without notice for modification and/or improvement. At the final stage of your design, purchasing, or use of the products, therefore, ask for the most up-to-date Product Standards in advance to make sure that the latest specifications satisfy your requirements.
- (6) When designing your equipment, comply with the guaranteed values, in particular those of maximum rating, the range of operating power supply voltage, and heat radiation characteristics. Otherwise, we will not be liable for any defect which may arise later in your equipment.  
Even when the products are used within the guaranteed values, take into the consideration of incidence of break down and failure mode, possible to occur to semiconductor products. Measures on the systems such as redundant design, arresting the spread of fire or preventing glitch are recommended in order to prevent physical injury, fire, social damages, for example, by using the products.
- (7) When using products for which damp-proof packing is required, observe the conditions (including shelf life and amount of time let standing of unsealed items) agreed upon when specification sheets are individually exchanged.
- (8) This material may be not reprinted or reproduced whether wholly or partially, without the prior written permission of Matsushita Electric Industrial Co., Ltd.



LittleDiode supplies new, hard to find or obsolete electronic components and semiconductors all over the world.

With over two million different components listed you are sure to find the part you need.

Feel free to visit us today at our online store:

[LittleDiode.com](http://LittleDiode.com)

Looking forward to providing you with the best possible service.