

AN8013SH

Single-channel step-up or step-down DC-DC converter control IC

Overview

The AN8013SH is a single-channel PWM DC-DC converter control IC. This IC implements DC-DC converters that provide a single arbitrary output voltage that is either a stepped-up or stepped-down level. It features a wide operating supply voltage range, low power, and a built-in overcurrent protection circuit to protect the switching transistor from damage or destruction. The AN8013SH is provided in a 0.5 mm pitch 10-pin surface mounting package and is optimal for use in miniature high-efficiency portable power supplies.

Features

- Wide operating supply voltage range (3.6 V to 34 V)
- Small consumption current (2.4 mA typical)
- Supports control over a wide output frequency range: 20 kHz to 500 kHz.
- Built-in pulse-by-pulse overcurrent protection circuit (Detection voltage: $V_{CC} - 100$ mV)
- Built-in timer latch short-circuit protection circuit (charge current 1.3 μ A typical)
- Incorporating the under-voltage lock-out (U.V.L.O.) circuit
- Built-in reference voltage circuit (Error amplifier reference input: 0.75 V (allowance: $\pm 4\%$))
- Output block is open-collector (darlington) type.
- High absolute maximum rating of output current (100 mA)
- Duty ratio with small sample-to-sample variations ($55\% \pm 5\%$).

Applications

- Switching mode power supply units (in portable equipment and other applications)

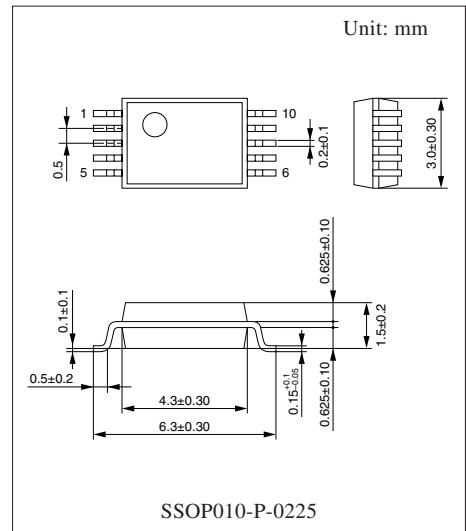

Note) The package of this product will be changed to lead-free type (SSOP010-P-0225A). See the new package dimensions section later of this datasheet.

Pin Descriptions

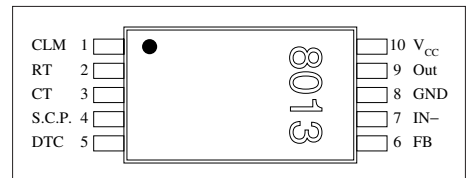

■ Block Diagram

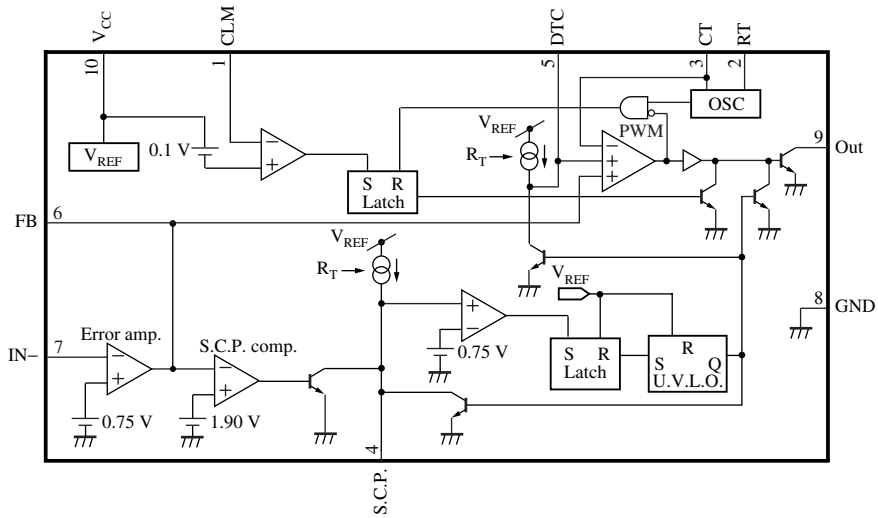

■ Absolute Maximum Ratings at $T_a = 25^\circ\text{C}$

Parameter	Symbol	Rating	Unit
Supply voltage	V_{CC}	35	V
CLM pin allowable application voltage	V_{CLM}	35	V
Error amplifier allowable input voltage	V_{IN-}	-0.3 to +2.5	V
DTC pin allowable input voltage	V_{DTC}	2.5	V
Out pin allowable application voltage	V_{OUT}	35	V
Collector output current	I_{OUT}	100	mA
Power dissipation ($T_a = 85^\circ\text{C}$)	P_D	154	mW
Operating ambient temperature	T_{opr}	-30 to +85	$^\circ\text{C}$
Storage temperature	T_{stg}	-55 to +150	$^\circ\text{C}$

■ Recommended Operating Range at $T_a = 25^\circ\text{C}$

Parameter	Symbol	Min	Max	Unit
Supply voltage rise time (0 V to 3.6 V)	$t_r (V_{CC})$	10	—	μs
Collector output voltage	V_{OUT}	—	34	V
Collector output current	I_{OUT}	—	50	mA
Timing capacitance	C_T	100	1800	pF
Timing resistance	R_T	5.1	15	$\text{k}\Omega$
Oscillator frequency	f_{OUT}	20	500	kHz
Short-circuit protection time constant setting capacitor	C_{SCP}	1000	—	pF

■ Electrical Characteristics at $T_a = 25^\circ\text{C}$

Parameter	Symbol	Conditions	Min	Typ	Max	Unit
U.V.L.O. block						
Circuit operation start voltage	V_{UON}		2.8	3.1	3.4	V
Hysteresis width	V_{HYS}		100	200	300	mV
Error amplifier block						
Input threshold voltage	V_{TH}	Voltage follower	0.72	0.75	0.78	mV
Line regulation with input fluctuation	V_{dv}	Voltage follower, $V_{CC} = 3.6\text{ V to }34\text{ V}$	—	2	8	mV
Input bias current	I_B		-500	-25	—	nA
High-level output voltage	V_{EH}		2.0	—	—	V
Low-level output voltage	V_{EL}		—	—	0.3	V
Input threshold voltage temperature characteristics 1	V_{dt1}	Voltage follower, $T_a = -30^\circ\text{C to }+25^\circ\text{C}$	—	± 1	—	%
Input threshold voltage temperature characteristics 2	V_{dt2}	Voltage follower, $T_a = -25^\circ\text{C to }+85^\circ\text{C}$	—	± 1	—	%
Output sink current	I_{SINK}	$V_{FB} = 0.9\text{ V}$	—	8	—	mA
Output source current	I_{SOURCE}	$V_{FB} = 0.9\text{ V}$	—	-120	—	μA
Open-loop gain	A_V		—	70	—	dB
PWM comparator block						
High-level input threshold voltage	V_{DT-H}	Duty: 100%	1.2	—	—	V
Low-level input threshold voltage	V_{DT-L}	Duty: 0%	—	—	0.6	V
Input current	I_{DTC}		-12	-11	-10	A
Output block						
Oscillation frequency	f_{OUT}	$R_T = 15\text{ k}\Omega$, $C_T = 150\text{ pF}$	185	205	225	kHz
Output duty	D_u	$R_{DTC} = 91\text{ k}\Omega$	50	55	60	%
Output saturation voltage	V_{OL}	$I_O = 50\text{ mA}$, $R_T = 15\text{ k}\Omega$	—	0.9	1.2	V
Output leak current	I_{LEAK}	$V_{CC} = 34\text{ V}$, when output Tr is off	—	—	10	μA
RT pin voltage	V_{RT}		—	0.59	—	V
Maximum oscillation frequency	$f_{OUT(max)}$	$R_T = 5.1\text{ k}\Omega$, $C_T = 120\text{ pF}$	—	500	—	kHz
Frequency supply voltage characteristics	f_{dv}	$f_{OUT} = 200\text{ kHz}$, $V_{CC} = 3.6\text{ V to }34\text{ V}$	—	± 1	—	%
Frequency temperature characteristics 1	f_{dT1}	$f_{OUT} = 200\text{ kHz}$, $T_a = -30^\circ\text{C to }+25^\circ\text{C}$	—	± 3	—	%
Frequency temperature characteristics 2	f_{dT2}	$f_{OUT} = 200\text{ kHz}$, $T_a = 25^\circ\text{C to }85^\circ\text{C}$	—	± 3	—	%

Note) At $V_{CC} = 12\text{ V}$, $R_T = 15\text{ k}\Omega$, $C_T = 15\text{ pF}$, unless otherwise specified.

■ Electrical Characteristics at $T_a = 25^\circ\text{C}$ (continued)

Parameter	Symbol	Conditions	Min	Typ	Max	Unit
Short-circuit protection circuit block						
Input threshold voltage	V_{THPC}		0.70	0.75	0.80	V
Input standby voltage	V_{STBY}		—	—	120	V
Input latch voltage	V_{IN}		—	—	120	mV
Charge current	I_{CHG}	$V_{SCP} = 0\text{ V}$	-1.6	-1.3	-1.0	μA
Comparator threshold voltage	V_{THL}		—	1.90	—	V
Overcurrent protection block						
Input threshold voltage	V_{CLM}		$V_{CC}-120$	$V_{CC}-100$	$V_{CC}-80$	mV
Delay time	t_{DLY}		—	200	—	ns
Whole device						
Total consumption current 1	I_{CC}	$R_T = 15\text{ k}\Omega$	—	2.4	3.5	mA
Total consumption current 2	I_{CC2}	$R_T = 5.1\text{ k}\Omega, C_T = 150\text{ pF}$	—	3.4	—	mA

Note) At $V_{CC} = 12\text{ V}$, $R_T = 15\text{ k}\Omega$, $C_T = 15\text{ pF}$, unless otherwise specified.



■ Terminal Equivalent Circuits

Pin No.	Pin	I/O	Function	Internal equivalent circuit
1	CLM	I	<p>Detects the overcurrent state in switching transistor.</p> <p>Insert a resistor with a low resistance between this pin and V_{CC} to detect overcurrent states. When this pin falls to a level 100 mV or more lower than V_{CC}, the PWM output is turned off for that period thus narrowing the width of the on period.</p> <p>(This implements a pulse-by-pulse overcurrent protection technique.)</p>	
2	RT	I	<p>Connection for the timing resistor that determines the oscillator frequency.</p> <p>Use a resistor in the range 5.1 kΩ to 15 kΩ. Thus the pin voltage will be about 0.59 V.</p>	
3	CT	O	<p>Connection for the timing capacitor that determines the oscillator frequency.</p> <p>Use a capacitor in the range 100 to 1 800 pF. See the "Application Notes, [2] and [3]" sections later in this document for details on setting the frequency. Use an oscillator frequency in the range 20 kHz to 500 kHz.</p>	

■ Terminal Equivalent Circuits (continued)

Pin No.	Pin	I/O	Function	Internal equivalent circuit
4	S.C.P.	O	<p>Connection for the capacitor that determines the time constant for soft start and the timer latch short-circuit protection circuit.</p> <p>Use a capacitor with a value of 1 000 pF or higher.</p> <p>The charge current I_{CHG} is determined by the timing resistor R_T, and sample-to-sample and temperature variations can be suppressed.</p> <p>When R_T is 15 kΩ, the current will be about -1.3 μA.</p> $I_{CHG} = \frac{V_{RT}}{R_T} \times \frac{1}{30} \text{ [A]}$	
5	DTC	I	<p>Connection for the resistor and capacitor that determine the PWM output dead-time and the soft start period.</p> <p>The input current I_{DTC} is determined by the timing resistor R_T, and sample-to-sample and temperature variations can be suppressed.</p> <p>When R_T is 15 kΩ, the current will be about -11 μA.</p> $I_{CHG} = \frac{V_{RT}}{R_T} \times \frac{1}{3.6} \text{ [A]}$	
6	FB	O	<p>Error amplifier output</p> <p>A source current is about -120 mA and a sink current is about 8 mA.</p> <p>Correct the gain and the phase frequency characteristics by inserting a resistor and a capacitor between this pin and IN- pin.</p>	
7	IN-	I	<p>Error amplifier inverting input</p> <p>For common-mode input, use in the range -0.1 V to +0.8 V.</p>	
8	GND	—	Ground	

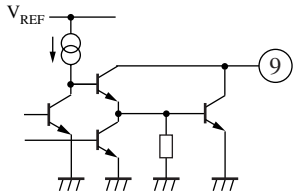
■ Terminal Equivalent Circuits (continued)

Pin No.	Pin	I/O	Function	Internal equivalent circuit
9	Out	O	Open-collector (darlington) output The absolute maximum rating for the output current is 100 mA. Use with a constant output current under 50 mA.	
10	V _{CC}	—	Power supply connection Provide the operating supply voltage in the range 3.6 V to 34 V.	

■ Application Notes

[1] Main characteristics

Error amplifier input threshold voltage temperature characteristics

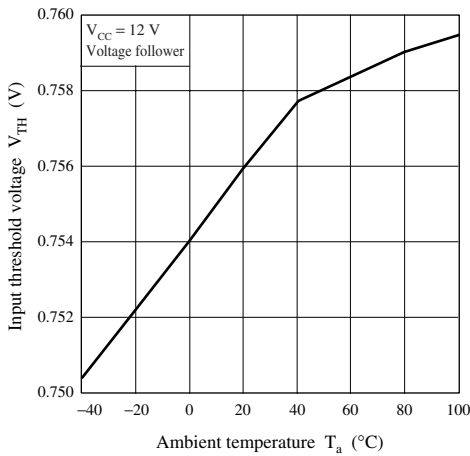

Maximum duty ratio temperature characteristics

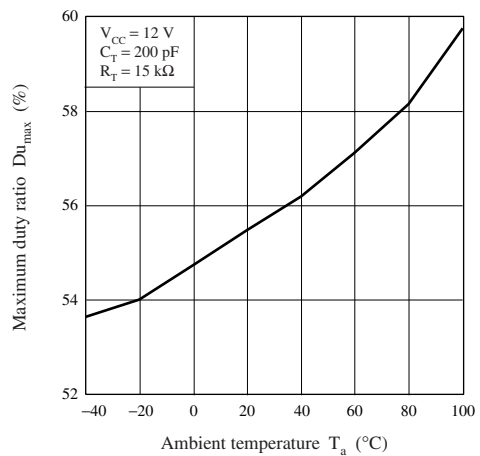

Oscillator frequency temperature characteristics

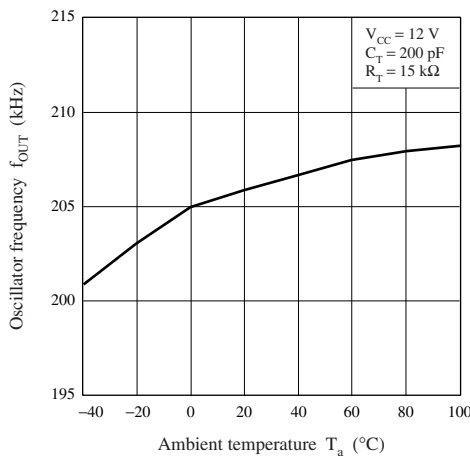

Timing capacitance — Oscillator frequency

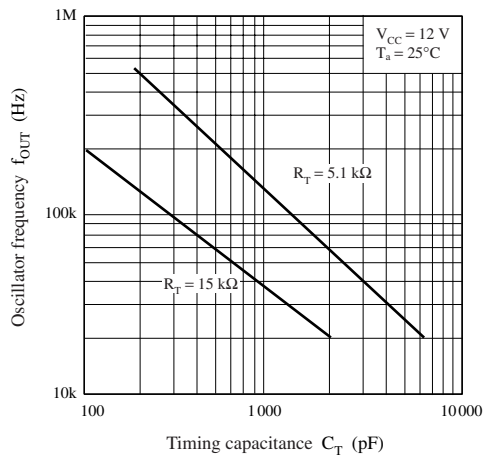

■ Application Notes (continued)

[1] Main characteristics (continued)

Input threshold voltage line regulation

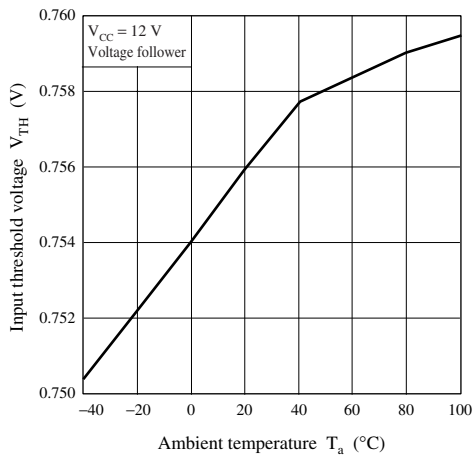

Total consumption current line regulation

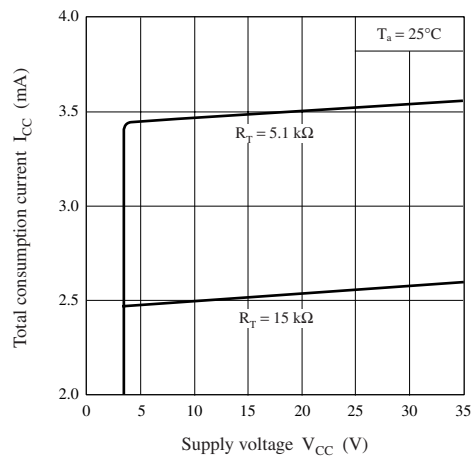

Timing resistance — Total consumption current

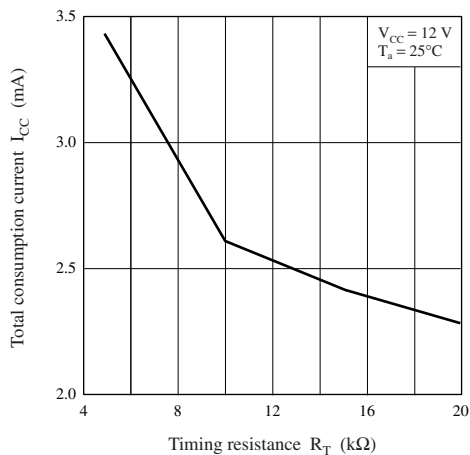

Timing resistance — Output saturation voltage

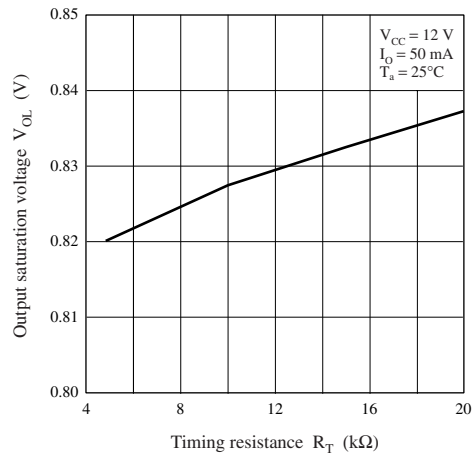

■ Application Notes

[2] Function descriptions

1. Reference voltage block

The reference voltage block is based on a band gap circuit, and outputs a temperature corrected reference voltage of 2.5 V. This reference voltage is stabilized once the supply voltage exceeds 3.6 V, and is used as the power supply for the IC itself.

2. Triangular wave generator

This circuit generates a triangular wave with a peak of about 1.45 V and a trough of about 0.35 V using a timing capacitor connected to the CT pin (pin 3) and a timing resistor connected to the RT pin (pin 2) respectively. The oscillator frequency can be set to arbitrary value by selecting appropriate values for the external capacitor and resistor, C_T and R_T . The triangular wave signal is provided to the inverting input the PWM comparator internally to the IC.

3. Error amplifier

This circuit is a pnp-transistor input error amplifier that detects and amplifies the DC-DC converter output voltage, and inputs that signal to a PWM comparator.

A 0.75 V level is created by resistors dividing the internal reference voltage. This level is applied to the noninverting input.

Arbitrary gain and phase compensation can be set up by inserting a resistor and capacitor in series between the error amplifier output pin (pin 6) and the inverting input pin (pin 7).

The output voltage V_{OUT} is given by the following formula by connecting a resistor divider to the output as shown in figure 1.

$$V_{OUT} = 0.75 \times \frac{R1 + R2}{R2}$$

4. Timer latch short-circuit protection circuit

This circuit protects the external main switching element, flywheel diode, choke coil, and other components against degradation or destruction if an excessive load or a short circuit of the power supply output continues for longer than a certain fixed period.

The timer latch short-circuit protection circuit detects the output of the error amplifier. If the DC-DC converter output voltage drops and an error amplifier output level exceeds 1.90 V, this circuit outputs a low level and the timer circuit starts. This starts charging the external protection circuit delay time capacitor.

If the error amplifier output does not return to the normal voltage range before that capacitor reaches 0.75 V, the latch circuit latches, the output drive transistors are turned off, and the dead-time is set to 100%.

5. Low input voltage malfunction prevention circuit (U.V.L.O.)

This circuit protects the system against degradation or destruction due to incorrect control operation when the power supply voltage falls during power on or power off.

The low input voltage malfunction prevention circuit detects the internal reference voltage that changes with the supply voltage level. While the supply voltage is rising, this circuit cuts off the output drive transistor until the reference voltage reaches 3.1 V. It also sets the dead-time to 100%, and at the same time holds the S.C.P. pin (pin 4) at the low level. During the fall time of the power supply voltage, it has hysteresis width of 200 mV and operates 2.9 V or less.

6. PWM comparator

The PWM comparator controls the output pulse on-period according to the input voltage. The output transistor is turned on during periods when the level of the CT pin (pin 3) triangular wave is lower than both of the error amplifier output (pin 6) and the DTC pin (pin 5) voltage.

The dead-time is set by adding a resistor between the DTC pin and ground.

Additionally, the AN8013SH can provide soft start operation in which the output pulse on-period is gradually lengthened according to an RC time constant when power is first applied by adding a capacitor in parallel with the resistor R_{DTC} .

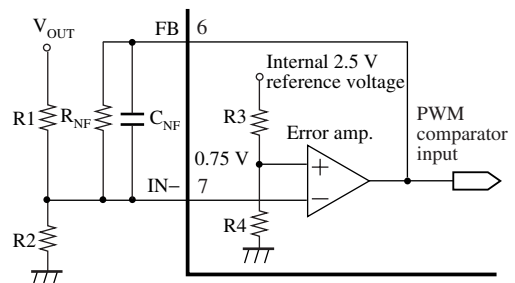

Figure 1. Connection method of error amplifier

■ Application Notes (continued)

[2] Function descriptions (continued)

7. Overcurrent protection block

Destruction of the main switching device, the flywheel diode, and the choke coil, which are easily damaged by overcurrents, is prevented by limiting the maximum current that flows in the switching device. This is implemented using the fact that power supply output overcurrents are proportional to the current flowing in the main switching device (a bipolar transistor).

The AN8013SH detects the current by connecting a resistor with a low resistance between the main switching device and the V_{CC} pin and monitoring the voltage drop across this resistor at the CLM pin (pin 1). When the main switching device (a bipolar transistor) is on and the CLM pin voltage reaches V_{CC} minus 100 mV, which is the overcurrent detection threshold voltage, the AN8013SH shuts off the output transistor, thus controlling the main switching device so that currents in excess of the limit cannot occur. While this control operation is repeated at each period, once an overcurrent is detected the output transistor is turned off for the remainder of that period and is not turned on again until the next period. This type of overcurrent protection is called pulse-by-pulse overcurrent protection.

8. Output block

The output drive transistor is of open-collector type output in which transistors are darlington-connected with a grounded common emitter. The breakdown voltage of collector output terminal (pin 5) is 34 V and it is possible to obtain up to 100 mA output current.

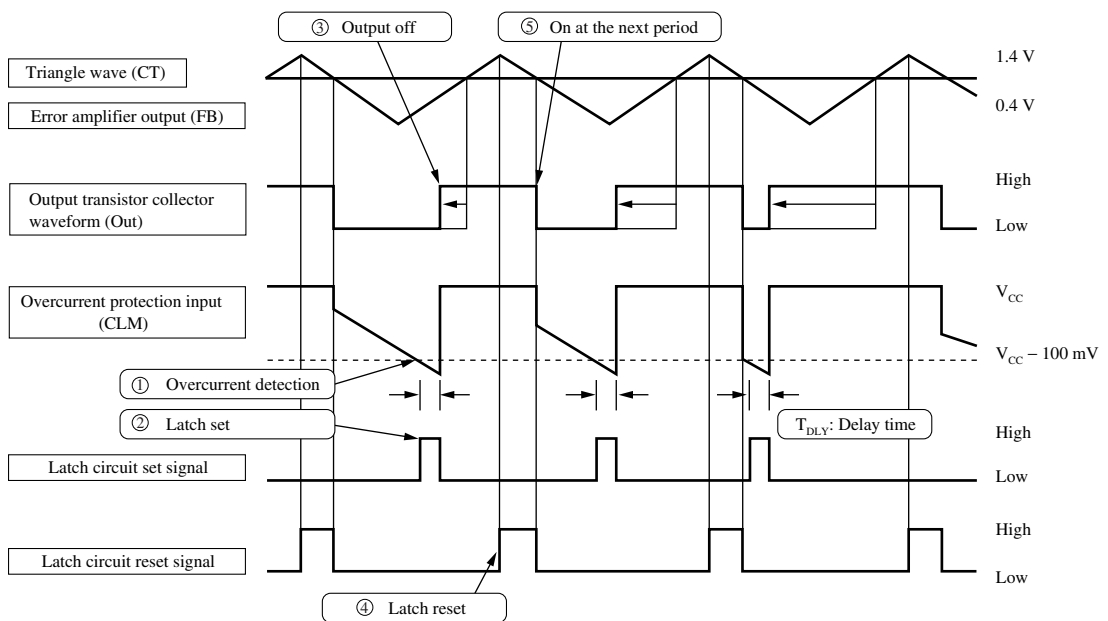

Figure 2. Pulse-by-pulse overcurrent protection operating waveforms

[3] Triangular wave oscillation circuit

1. Setting the oscillator frequency

The waveform of triangular wave oscillation is obtained by charging and discharging of the constant current I_O from the external timing capacitor C_T which is connected to CT pin (pin 3). The constant current is set by the externally attached timing resistor R_T .

The peak value of the wave V_{CTH} and the trough value of the wave V_{CTL} are fixed at about 1.45 V typical and 0.35 V typical respectively.

■ Application Notes (continued)

[3] Triangular wave oscillation circuit (continued)

1. Setting the oscillator frequency (continued)

The oscillator frequency f_{OSC} is obtained by the following formula:

$$f_{OSC} = \frac{1}{t_1 + t_2} = \frac{I_O}{2 \times C_T \times (V_{CTH} - V_{CTL})}$$

whereas $I_O = 1.8 \times \frac{V_{RT}}{R_T} = 1.8 \times \frac{0.59}{R_T}$

because $V_{CTH} - V_{CTL} = 1.1 \text{ V}$

$$f_{OSC} = \frac{1}{2.07 \times C_T \times R_T} \text{ [Hz]}$$

The output frequency f_{OUT} is equal to f_{OSC} since it is PWM-controlled.

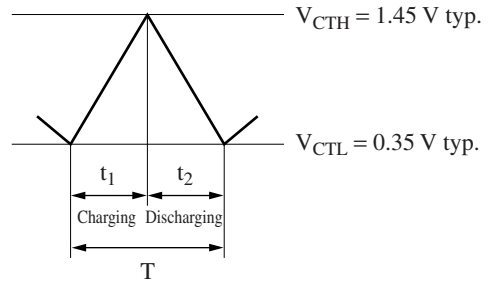

Figure 3. Triangular wave oscillation waveform

2. Usage notes

This IC uses the constant current given by the timing resistor R_T as the bias current of the triangular wave generator and the PWM comparator for consumption current reduction. The total consumption current is about 2.4 mA typical when R_T is 15 k Ω , and it increases to about 3.4 mA typical when R_T is 5.1 k Ω . In order to obtain the constant output current of 100 mA at the open-collector output, it is necessary to set R_T value to 15 k Ω or smaller.

It is possible to use the circuit in the recommended operating range of 20 kHz to 500 kHz of the oscillator frequency. As the AN8013SH is used at increasingly higher frequencies, the amount of overshoot and undershoot due to the operation delay in the triangular wave oscillator comparator increases, and discrepancies between the values calculated as described previously and the actual values may occur. See the timing capacitance - oscillator frequency relationship in the "Application Notes, [1] Main characteristics" section of this document.

Note that this IC can not be used as an IC for slave when the several ICs are operated in parallel synchronous mode.

[4] Setting the dead-time (maximum duty)

The dead-time is set, as shown in figure 4, by setting the DTC pin (pin 5) voltage, V_{DTC} . Since the DTC pin has a constant current output set with the resistor R_T , V_{DTC} is adjusted by adding the external resistor R_{DTC} . The output duty, Du , and the DTC pin voltage, V_{DTC} , are expressed by the following formulas. For an oscillator frequency of 200 kHz, the output duty will be 0% at $V_{DTC} = 0.45 \text{ V}$, and 100% at $V_{DTC} = 1.45 \text{ V}$. However, care is required here, since the amount of overshoot and undershoot in the triangular wave peak (V_{CTH}) and minimum (V_{CTL}) values depends on the oscillator frequency.

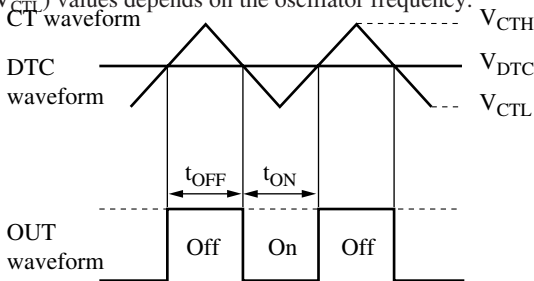

$$Du = \frac{t_{ON}}{t_{ON} + t_{OFF}} \times 100 \text{ [%]}$$

$$= \frac{V_{CTH} - V_{DTC}}{V_{CTH} - V_{CTL}} \times 100 \text{ [%]}$$

$$V_{DTC} = I_{DTC} \times R_{DTC}$$

$$= V_{RT} \times \frac{R_{DTC}}{R_T} \times \frac{1}{3.6} \text{ [V]}$$

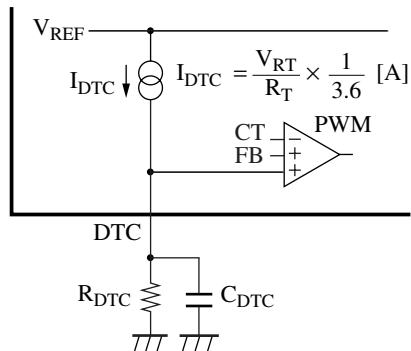

Example: When $f_{OSC} = 200 \text{ kHz}$ ($R_T = 15 \text{ k}\Omega$, $C_T = 150 \text{ pF}$)
 $V_{CTH} \approx 1.45 \text{ V (typ.)}$ $V_{RT} \approx 0.59 \text{ V (typ.)}$
 $V_{CTL} \approx 0.35 \text{ V (typ.)}$ $I_{DTC} \approx 11 \mu\text{A (typ.)}$

Figure 4. Setting the dead-time

■ Application Notes (continued)

[4] Setting the dead-time (maximum duty) (continued)

Adding the external resistor R_{DTC} and the capacitor C_{DTC} in parallel implements a soft start function that causes the output pulse on width to increase gradually when the power supply is started. Use of this function can prevent DC-DC converter output overshoot.

[5] Setting the time constant of the timer latch short-circuit protection circuit

The structural block diagram of protection latch circuit is shown in figure 5. The comparator for short-circuit protection compares the output of error amplifier V_{FB} with the reference voltage of 1.90 V all the time.

When the load conditions of DC-DC converter output are stabilized, there is no fluctuation of error amplifier output, and the short-circuit protection comparator also keeps the balance. At this moment, the output transistor Q1 is in the conductive state and the S.C.P. pin is hold to about 30 mV through the clamp circuit.

When the load conditions suddenly change, and high-level signal (1.90 V or higher) is input from the error amplifier to the non-inverted input of the short-circuit protection comparator, the short-circuit protection comparator outputs the low-level signal. Since this signal cuts off the output transistor Q1, the S.C.P. pin voltage V_{PE} is released, and the externally connected capacitor C_S starts charging according to the following equation:

$$V_{PE} = V_{STBY} + I_{CHG} \times \frac{t_{PE}}{C_S} \text{ [V]}$$

$$0.75 \text{ V} = 0.03 \text{ V} + I_{CHG} \times \frac{t_{PE}}{C_S}$$

$$C_S = I_{CHG} \times \frac{t_{PE}}{0.72} \text{ [F]}$$

I_{CHG} is the constant current determined by the oscillation timing resistor R_T , and its dispersion and fluctuation with temperature are small. I_{CHO} is expressed in the following equation:

$$I_{CHG} = \frac{V_{RT}}{R_T} \times \frac{1}{30} \text{ [A]}$$

V_{RT} is about 0.5 V and I_{CHO} becomes about 1.1 μA at $R_T = 15 \text{ k}\Omega$.

Once the low input voltage malfunction prevention circuit is enabled, the S.C.P. pin voltage is discharged to about 30 mV but the latch circuit is not reset unless the power is turned off.

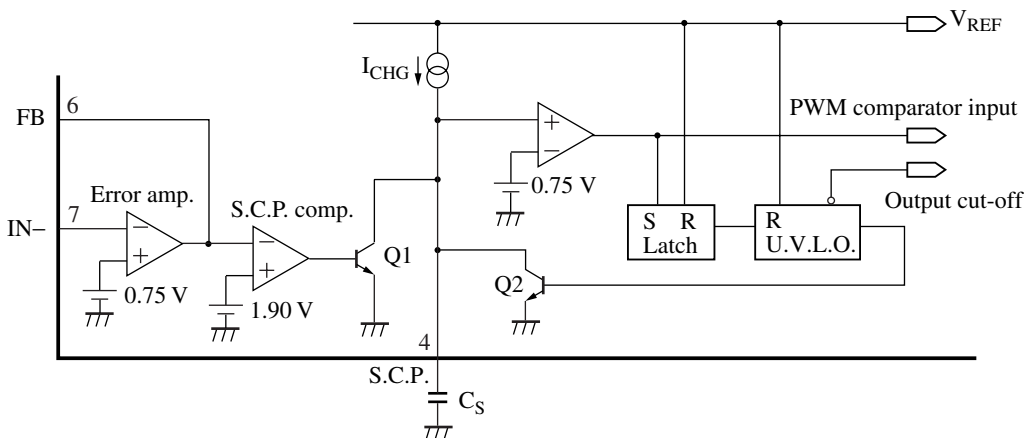

Figure 5. Short-circuit protection circuit

When the power supply is started, the output appears to be shorted. The error amplifier output goes to the high state, the S.C.P. pin voltage, V_{PE} , is released, and charging starts. The external capacitor value must be set so that DC-DC converter voltage output starts before the latch circuit in the later stage is set. If the soft start function is used, special care is required to assure that the start time does not become excessive.

■ Application Notes (continued)

[6] Timing chart

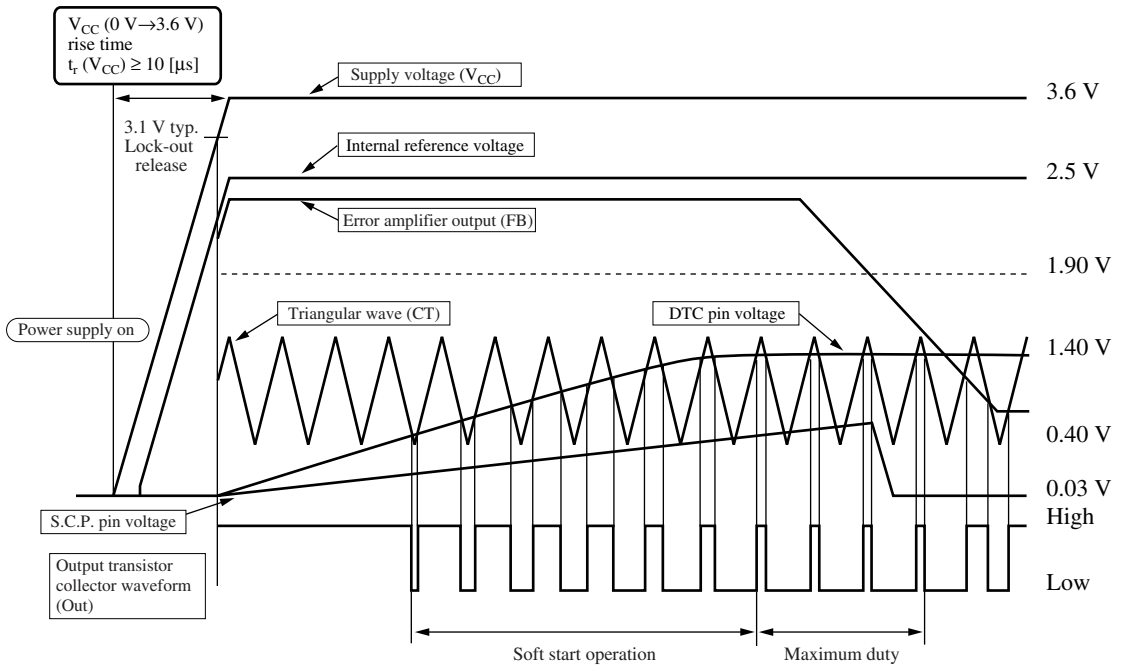

Figure 6. PWM comparator operation waveform

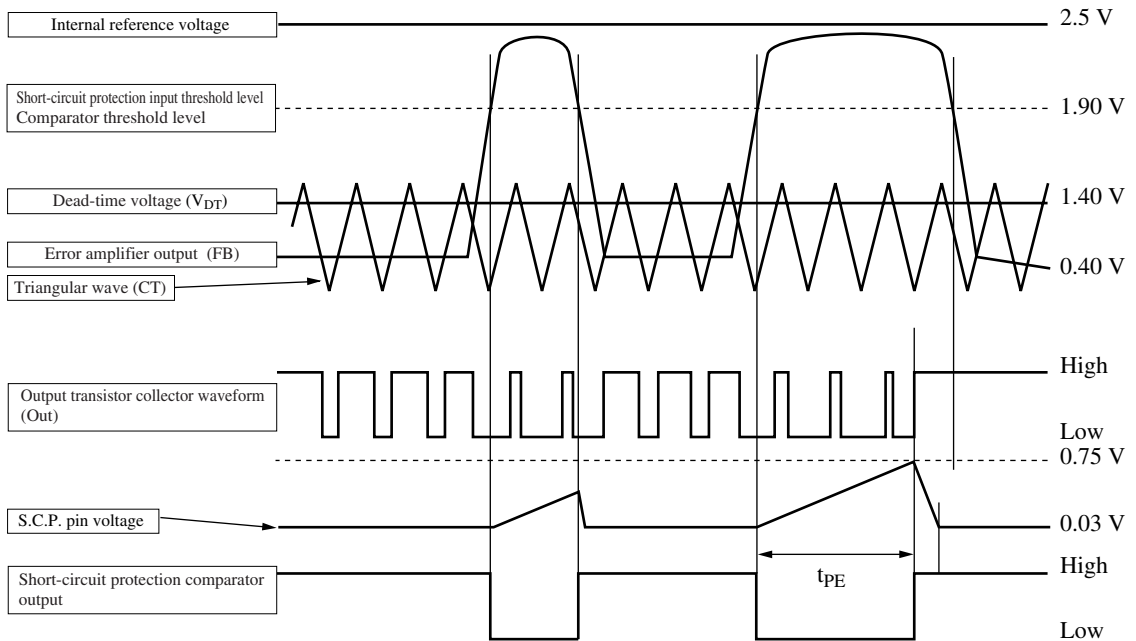
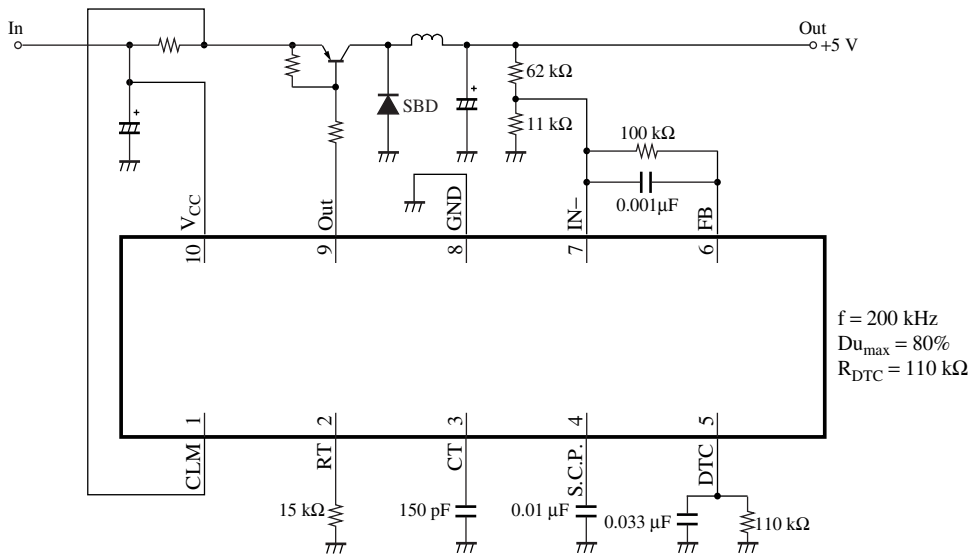

Figure 7. Short-circuit protection operation waveform

■ Application Circuit Examples

1. Step-down circuit



2. Step-up circuit

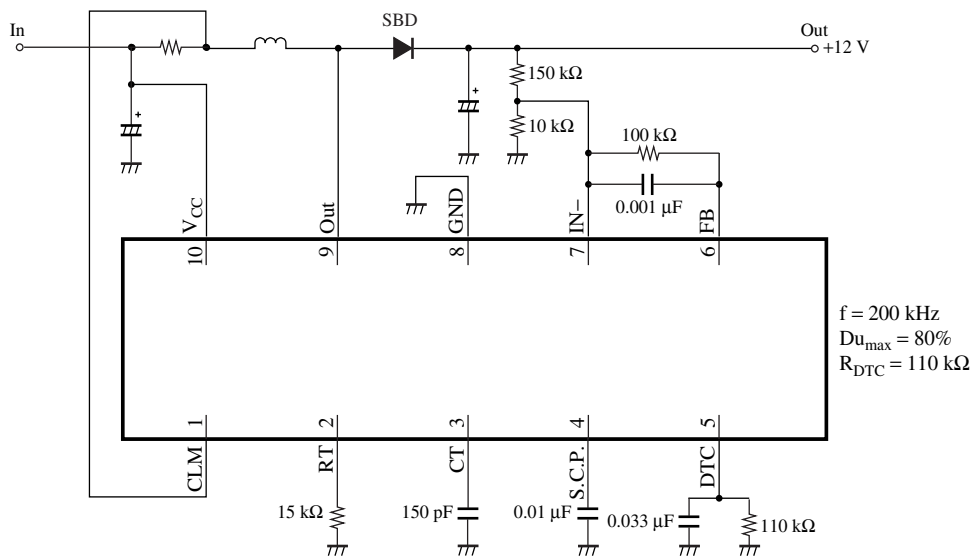

■ Application Circuit Examples (continued)

3. On/off circuit example

1) Cutting the power supply line

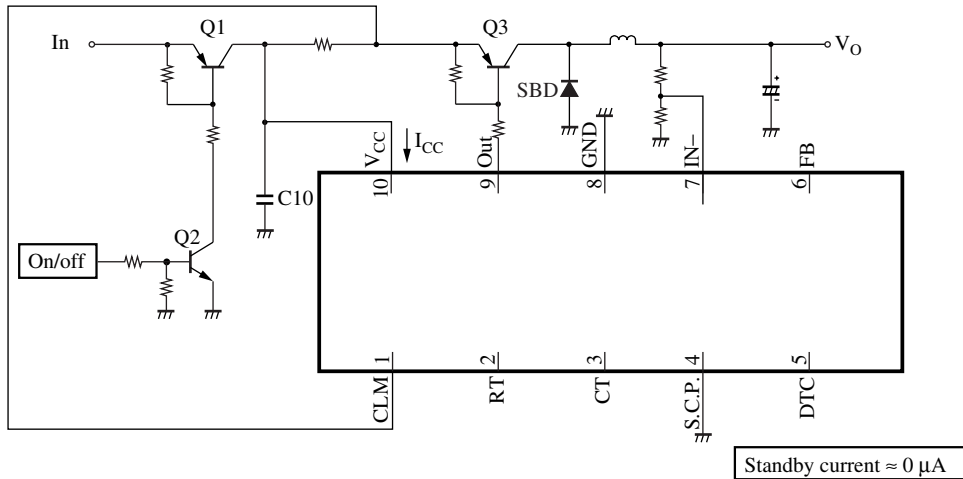

2) Cutting the IC V_{CC} line

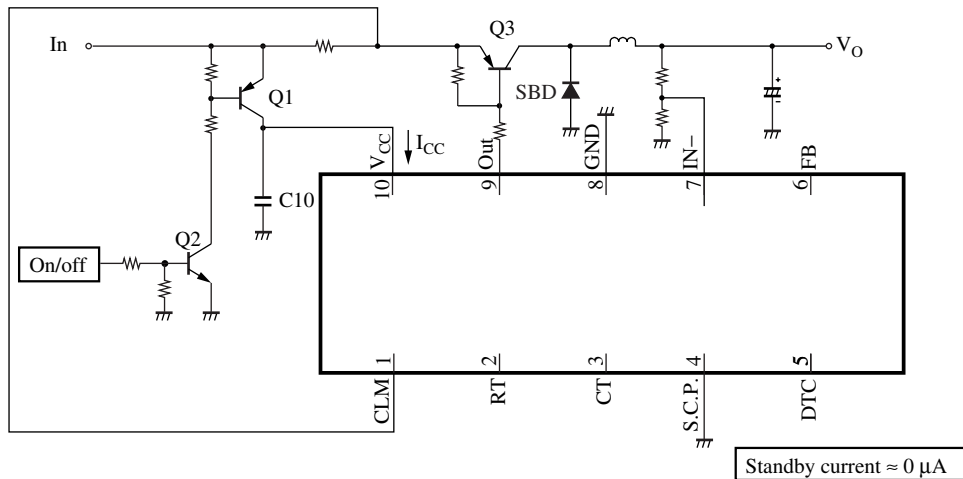

4. Usage

Since this IC does not include an on/off circuit, an external circuit must be added to implement a standby function.

If a switch (Q1) is inserted in the power supply line as shown in on/off circuit example 1, the standby current can be held to 0. In this circuit, a transistor essentially equivalent to the one used for the main switching device (Q3) is required.

If a switch (Q1) is inserted between the power supply line and the IC V_{CC} pin (pin 10) as shown in on/off circuit example 2, the size of the switching device (Q1) can be reduced. However, the sample-to-sample variations in the Q1 saturation voltage will result in sample-to-sample variations in the overcurrent protection threshold level.

5. Usage Notes

If an external on/off circuit is added, the V_{CC} rise time may become excessively steep and the IC internal latch circuit may be set at that time, causing problems at power supply startup. To avoid such problems, set the value of C10 so that the V_{CC} (pin 10) rise time is at least 10 μ s.

■ New Package Dimensions (Unit: mm)

- SSOP010-P-0225A (Lead-free package)

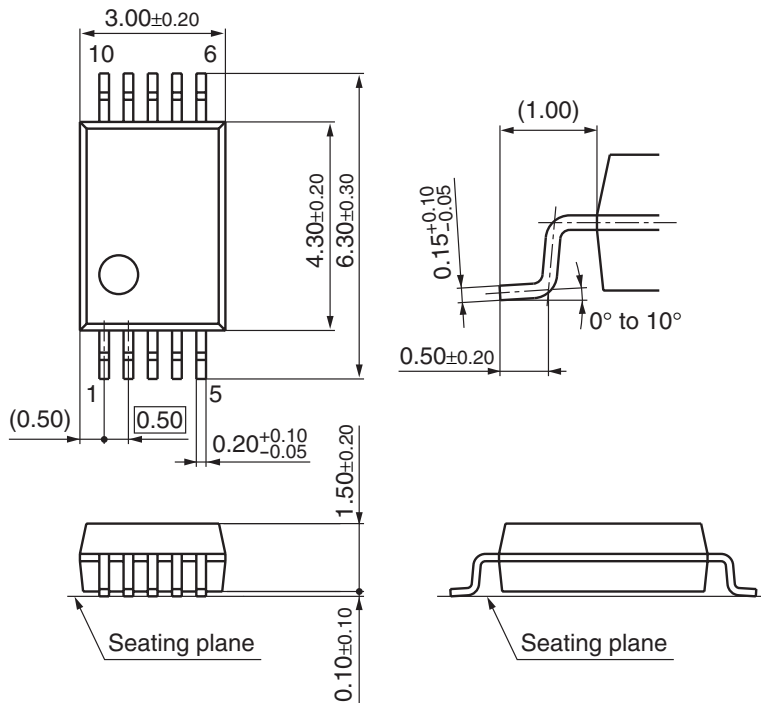

Request for your special attention and precautions in using the technical information and semiconductors described in this material

- (1) An export permit needs to be obtained from the competent authorities of the Japanese Government if any of the products or technologies described in this material and controlled under the "Foreign Exchange and Foreign Trade Law" is to be exported or taken out of Japan.
- (2) The technical information described in this material is limited to showing representative characteristics and applied circuits examples of the products. It neither warrants non-infringement of intellectual property right or any other rights owned by our company or a third party, nor grants any license.
- (3) We are not liable for the infringement of rights owned by a third party arising out of the use of the product or technologies as described in this material.
- (4) The products described in this material are intended to be used for standard applications or general electronic equipment (such as office equipment, communications equipment, measuring instruments and household appliances).
Consult our sales staff in advance for information on the following applications:
 - Special applications (such as for airplanes, aerospace, automobiles, traffic control equipment, combustion equipment, life support systems and safety devices) in which exceptional quality and reliability are required, or if the failure or malfunction of the products may directly jeopardize life or harm the human body.
 - Any applications other than the standard applications intended.
- (5) The products and product specifications described in this material are subject to change without notice for modification and/or improvement. At the final stage of your design, purchasing, or use of the products, therefore, ask for the most up-to-date Product Standards in advance to make sure that the latest specifications satisfy your requirements.
- (6) When designing your equipment, comply with the guaranteed values, in particular those of maximum rating, the range of operating power supply voltage, and heat radiation characteristics. Otherwise, we will not be liable for any defect which may arise later in your equipment.
Even when the products are used within the guaranteed values, take into the consideration of incidence of break down and failure mode, possible to occur to semiconductor products. Measures on the systems such as redundant design, arresting the spread of fire or preventing glitch are recommended in order to prevent physical injury, fire, social damages, for example, by using the products.
- (7) When using products for which damp-proof packing is required, observe the conditions (including shelf life and amount of time let standing of unsealed items) agreed upon when specification sheets are individually exchanged.
- (8) This material may be not reprinted or reproduced whether wholly or partially, without the prior written permission of Matsushita Electric Industrial Co., Ltd.



LittleDiode supplies new, hard to find or obsolete electronic components and semiconductors all over the world.

With over two million different components listed you are sure to find the part you need.

Feel free to visit us today at our online store:

LittleDiode.com

Looking forward to providing you with the best possible service.