

# AN8011S

## 2-channel step-down, step-up, or inverting use DC-DC converter control IC

### Overview

The AN8011S is a DC-DC converter control IC with two-channel output using the PWM method which allows 500 kHz high-speed control.

Respective output operation can be completely synchronized with each other by using the same oscillation output.

### Features

- PWM control frequency of 500 kHz is available.
- Wide operating supply voltage range ( $V_{CC} = 3.6 \text{ V to } 34 \text{ V}$ )
- Built-in 2-channel of open collector type for output (A single-channel is also usable for inverted amplification type)
- Each output can be stopped independently by the external control .
- Built-in on/off function for the operation/stop of IC Incorporating circuit for short-circuit protection and under-voltage lock-out (U.V.L.O.)
- The latch circuit is externally controllable.
- Low consumption current (during operation: 5 mA, during standby: 2  $\mu\text{A}$ )

### Applications

- LCD displays, digital still cameras, and PDAs

### Block Diagram

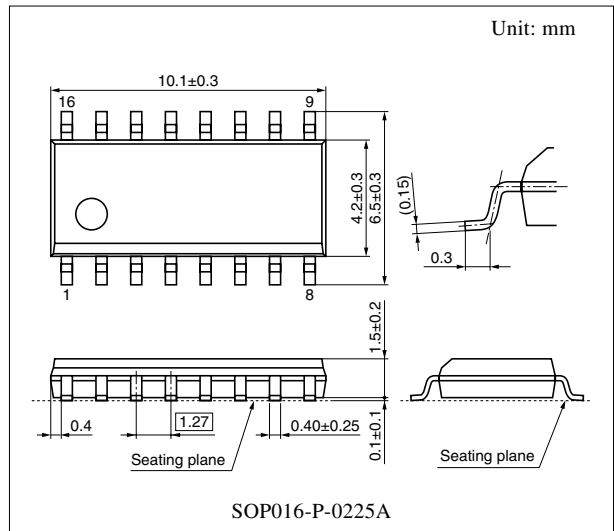
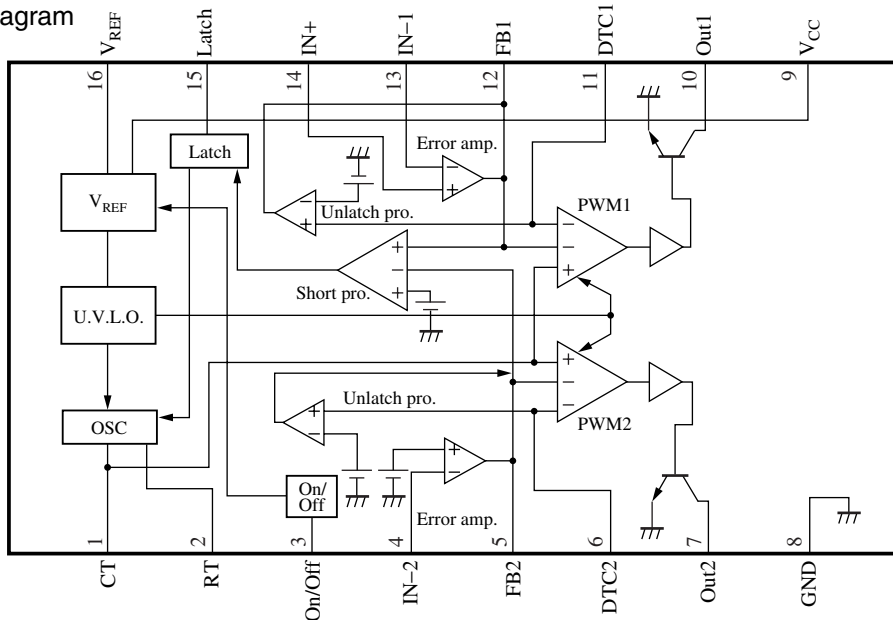

(Note) The package of this product will be changed to lead-free type (SOP016-P-0225E). See the new package dimensions section later of this datasheet.

## ■ Pin Descriptions

Pin No.	Symbol	Description
1	CT	Pin for connecting the oscillation frequency setting capacitor for triangular oscillation circuit. Frequency of triangular oscillation is set by connecting a capacitor between this terminal and GND.
2	RT	Resistor connection pin for setting the oscillation frequency of triangular oscillation circuit. Frequency of triangular oscillation is set by connecting resistance between the pin and GND
3	On/Off	"On/Off" pin for turning on/off IC. "Low" stops IC (output off) and "High" operates IC.
4	IN-2	Inverted input pin for channel 2 error amplifier
5	F/B 2	Output pin for channel 2 error amplifier. Gain setting or phase compensation is performed by connecting resistor or capacitor between the pin and IN-2. It is also connected to PWM short-circuit protection.
6	DTC 2	Pin for setting dead-time period of channel 2. The dead-time of channel 2 is set by connecting external resistor. Soft start function can be also given by connecting capacitor in parallel with the external resistor. In addition, only channel 2 output can be turned off by decreasing the pin voltage to below 0.12 V. (short-circuit protection function stop circuit)
7	Out 2	Channel 2 open-collector type output pin. $I_O = 100$ mA maximum
8	GND	Grounding pin of signal system.
9	V <sub>CC</sub>	Power supply voltage application pin. It detects start voltage and stop voltages
10	Out 1	Channel 1 open-collector type output pin. $I_O = 100$ mA maximum
11	DTC 1	Pin for setting dead-time period of channel 1. The dead-time period of channel 1 is set by connecting external resistor. Soft start function can be also given by connecting capacitor in parallel with the external resistor. In addition, only channel 1 output can be turned off by decreasing the pin voltage to below 0.12 V. (short-circuit protection function stop circuit)
12	F/B 1	Output pin for channel 1 error amplifier. Gain setting or phase compensation is performed by connecting resistor or capacitor between the pin and IN-1. It is also connected to PWM short-circuit protection.
13	IN-1	Inverted input pin for channel 1 error amplifier.
14	IN+	Pin for noninverted input of channel 1 error amplifier.
15	Latch	Pin for connecting the time constant setting capacitor for timer latch type short-circuit protection circuit. The time constant for short-circuit protection is set by connecting a capacitor between this terminal and GND.
16	V <sub>REF</sub>	Internal reference voltage output pin (2.5 V (allowance: $\pm 3\%$ )). If a load of 20 mA typical or more is applied, the overcurrent protection operates to reduce V <sub>REF</sub> and switching operation stops.

### ■ Absolute Maximum Ratings at $T_a = 25^\circ\text{C}$

Parameter	Symbol	Rating	Unit
Supply voltage	$V_{CC}$	35	V
Power dissipation *	$P_D$	380	mW
Operating ambient temperature	$T_{opr}$	-30 to +85	$^\circ\text{C}$
Storage temperature	$T_{stg}$	-40 to +125	$^\circ\text{C}$

Note) 1. Do not apply external currents or voltages to any pins not specifically mentioned.

For circuit currents, '+' denotes current flowing into the IC, and '-' denotes current flowing out of the IC.

2 \*: When using the IC at  $T_a$  of  $25^\circ\text{C}$  or more, the power dissipation should be decreased 3.8 mW per  $1^\circ\text{C}$ .

### ■ Recommended Operating Range

Parameter	Symbol	Range	Unit
Supply voltage	$V_{CC}$	3.6 to 34	V

### ■ Electrical Characteristics at $V_{CC} = 12\text{ V}$ , $T_a = 25^\circ\text{C}$

Parameter	Symbol	Conditions	Min	Typ	Max	Unit
Reference voltage block						
Output voltage	$V_{REF}$		2.413	2.5	2.588	V
Input regulation with input fluctuation	Line	$V_{CC} = 3.6\text{ V to }34\text{ V}$	—	3	20	mV
Load regulation	Load	$I_{REF} = 0\text{ mA to }5\text{ mA}$	—	2	10	mV
Output voltage temperature characteristics 1 *	$V_{TC1}$	$T_a = -25^\circ\text{C to }+25^\circ\text{C}$	—	$\pm 1$	—	%
Output voltage temperature characteristics 2 *	$V_{TC2}$	$T_a = 25^\circ\text{C to }85^\circ\text{C}$	—	$\pm 1$	—	%
Overcurrent protection drive current *	$I_{CC}$		—	-20	—	mA
U.V.L.O. block						
Circuit operation start voltage	$V_{UON}$		2.8	3.1	3.4	V
Hysteresis width	$V_{HYS}$		100	200	300	mV
Error amplifier block 1						
Input offset voltage 1	$V_{IN-O1}$		-6	—	6	mV
Input current 1	$I_{B1}$		-500	-25	100	nA
Common-mode input voltage range	$V_{CM}$		0.5	—	0.8	V
High-level output voltage 1	$V_{EH1}$		$V_{REF}-0.3$	—	—	V
Low-level output voltage 1	$V_{EL1}$		—	—	0.5	V
Error amplifier block 2						
Input current 2	$I_{B2}$		25	—	100	nA
Common mode input threshold voltage	$V_{IN+}$		0.72	0.75	0.78	V
High-level output voltage 2	$V_{EH2}$		$V_{REF}-0.3$	—	—	V
Low-level output voltage 2	$V_{EL2}$		—	—	0.5	V

**■ Electrical Characteristics at  $V_{CC} = 12\text{ V}$ ,  $T_a = 25^\circ\text{C}$  (continued)**

Parameter	Symbol	Conditions	Min	Typ	Max	Unit
<b>PWM comparator 1/2 block</b>						
High-level input threshold voltage	$V_{DT-H}$	$f_{OSC} = 200\text{ kHz}$ , duty = 100%	1.2	—	—	V
Low-level input threshold voltage	$V_{DT-L}$	$f_{OSC} = 200\text{ kHz}$ , duty = 100%	—	—	0.6	V
Input current	$I_{DTC}$	$R_T = 20\text{ k}\Omega$	-37	-34	-31	$\mu\text{A}$
<b>Output 1/2 block</b>						
Output frequency 1	$f_{OUT1}$	$C_T = 150\text{ pF}$ , $R_T = 20\text{ k}\Omega$ , $I_O = 30\text{ mA}$	180	200	220	kHz
Frequency 1	$f_{dv}$	$V_{CC} = 3.6\text{ V to }34\text{ V}$ $C_T = 150\text{ pF}$ , $R_T = 20\text{ k}\Omega$	-2	—	2	%
Output duty ratio 1	$Du_1$	$C_T = 150\text{ pF}$ , $R_T = 20\text{ k}\Omega$ , $R_{DTC} = 24\text{ k}\Omega$	40	45	50	%
Output duty ratio 2	$Du_2$	$C_T = 150\text{ pF}$ , $R_T = 20\text{ k}\Omega$ , $R_{DTC} = 33\text{ k}\Omega$	65	75	85	%
Output saturation voltage 1	$V_{O(sat)1}$	$I_O = 30\text{ mA}$	—	—	0.9	V
Output saturation voltage 2	$V_{O(sat)2}$	$I_O = 100\text{ mA}$	—	—	1.2	V
Output leak current 1	$I_{OLe1}$	$V_{CC} = 34\text{ V}$ , when output transistor is off	—	—	10	$\mu\text{A}$
Frequency temperature characteristics 1 *	$f_{dT1}$	$f_{OSC} = 200\text{ kHz}$ , $T_a = -30^\circ\text{C to }+25^\circ\text{C}$	—	$\pm 9$	—	%
Frequency temperature characteristics 2 *	$f_{dT2}$	$f_{OSC} = 200\text{ kHz}$ , $T_a = 25^\circ\text{C to }85^\circ\text{C}$	—	$\pm 9$	—	%
Output frequency 2 *	$f_{OUT2}$	$C_T = 150\text{ pF}$ , $R_T = 6.6\text{ k}\Omega$ , $I_O = 30\text{ mA}$	—	500	—	kHz
Frequency 2 *	$f_{dv2}$	$V_{CC} = 3.6\text{ V to }34\text{ V}$ , $C_T = 150\text{ pF}$ , $R_T = 6.6\text{ k}\Omega$	—	$\pm 2$	—	%
<b>Short-circuit protection block</b>						
Input threshold voltage	$V_{SLTH}$		1.75	1.85	1.95	V
Latch drive voltage	$V_{SLON}$		1.15	1.25	1.35	V
Charge current	$I_{CHG}$		-120	-50	-40	$\mu\text{A}$
<b>Unlatch pro. 1/2 block</b>						
Input threshold voltage	$V_{ULTH}$		0.12	—	—	V
<b>On/off block</b>						
Threshold voltage	$V_{TH}$		0.8	—	2	V
<b>Whole device</b>						
Total consumption current	$I_{CC}$	$V_{CC} = 12\text{ V}$ , $R_T = 20\text{ k}\Omega$	—	5	7	mA
Total consumption current fluctuation	$I_{CC(max.)}$	$V_{CC} = 3.6\text{ V to }34\text{ V}$ , $R_T = 20\text{ k}\Omega$	—	—	2	mA
Standby consumption current	$I_{CC(SB)}$	$V_{CC} = 12\text{ V}$ , $V_{REF}$ is down	—	—	2	$\mu\text{A}$
Maximum standby consumption current	$I_{CC(SB-M)}$	$V_{CC} = 34\text{ V}$ , $V_{REF}$ is down	—	—	5	$\mu\text{A}$

Note) \*: These characteristics are theoretical values based on the IC design and are not guaranteed.

■ Terminal Equivalent Circuits

Pin No.	Equivalent circuit	Description	I/O
1		<p>CT:</p> <p>The terminal used for connecting a timing capacitor to set oscillator frequency. Use a capacitance value within the range of 100 pF to 0.1 mF. For frequency setting method, refer to the "Application Notes, [2] Function descriptions" section. Use the oscillation frequency in the range of 1 kHz to 500 kHz.</p>	O
2		<p>RT:</p> <p>The terminal used for connecting a timing resistor to set oscillation frequency. Use a resistance value ranging from 5.1 kΩ to 20 kΩ. The terminal voltage is 0.67 V typ.</p>	I
3		<p>On/Off:</p> <p>The terminal for on/off control.</p> <p>High-level input: normal operation (<math>V_{ON/OFF} &gt; 2.0</math> V typ.)</p> <p>Low-level input: standby state (<math>V_{ON/OFF} &lt; 0.8</math> V typ.)</p> <p>The total current consumption in the standby state can be suppressed to a value below 5 μA.</p>	I
4		<p>IN-2:</p> <p>The terminal for the inverted input of ch.2 error amplifier. Use a common-mode input ranging from -0.1 V to 0.8 V.</p>	I

### ■ Terminal Equivalent Circuits (continued)

Pin No.	Equivalent circuit	Description	I/O
5		<p><b>FB2:</b> The output terminal of ch.2 error amplifier. Its source current is <math>-25 \mu\text{A}</math> typ. and sink current is <math>8 \text{ mA}</math> typ.</p> <p>Correct the frequency characteristics of the gain and the phase by connecting a resistor and a capacitor between the terminal and IN-2 terminal.</p>	O
6		<p><b>DTC2:</b> 1) Terminal for connecting a resistor and a capacitor for setting the dead-time and the soft start period of ch.2 PWM output.</p> <p>Input current <math>I_{DTC}</math> is determined by the timing resistor <math>R_T</math> so that dispersion, and fluctuation with temperature are suppressed. The input current is <math>-35 \mu\text{A}</math> typ. when <math>R_T = 20 \text{ k}\Omega</math></p> $I_{DTC2} = \frac{V_{RT}}{R_T} \times 1.04 \text{ (A)}$ <p style="text-align: center;">(<math>V_{RT}</math>: <math>0.67 \text{ V}</math> typ.)</p> <p>2) The ch.2 output can be turned off by reducing the terminal voltage to below <math>0.12 \text{ V}</math>. (short-circuit protection function stop)</p>	I
7		<p><b>Out2:</b> The ch.2 open-collector type (Darlington) output terminal.</p> <p>The absolute maximum rating of output current is <math>150 \text{ mA}</math>.</p> <p>Use with an output current under <math>100 \text{ mA}</math> normally.</p>	O
8		<p><b>GND:</b> GND pin</p>	—
9		<p><b>V<sub>CC</sub>:</b> The pin to which supply voltage is applied. Use within an operating supply voltage range of <math>3.6 \text{ V}</math> to <math>34 \text{ V}</math>.</p>	—

■ Terminal Equivalent Circuits (continued)

Pin No.	Equivalent circuit	Description	I/O
10		<p>Out1: The ch.1 open collector type (darlington) output terminal. The absolute maximum rating of output current is 150 mA. Use with an output current of 100 mA or less normally.</p>	O
11		<p>DTC1: 1) Terminal for connecting a resistor and a capacitor for setting the dead-time and the soft start period of ch.1 PWM output. Input current <math>I_{DTC}</math> is determined by the timing resistor <math>R_T</math> so that dispersion and fluctuation with temperature are suppressed. The input current is <math>-35 \mu\text{A}</math> typ, when <math>R_T = 20 \text{ k}\Omega</math>. <math display="block">I_{DTC2} = \frac{V_{RT}}{R_T} \times 1.04 \text{ (A)}</math> (<math>V_{RT}</math>: 0.67 V typ.) 2) The ch.1 output can be turned off by reducing the terminal voltage to below 0.12 V. (short-circuit protection function stop)</p>	I
12		<p>FB1: The output terminal of ch.1 error amplifier. Its source current is <math>-25 \mu\text{A}</math> typ. and sink current is 8 mA typ. Correct the frequency characteristics of the gain and the phase by connecting a resistor and a capacitor between the terminal and IN-1 terminal.</p>	O
13		<p>IN-1: The terminal for the inverted input of ch.1 error amplifier. Use a common-mode input ranging from <math>-0.1 \text{ V}</math> to <math>+0.8 \text{ V}</math>.</p>	I
14		<p>IN+: The terminal for noninverted input of ch.1 error amplifier. Use a common-mode input ranging from <math>-0.1 \text{ V}</math> to <math>+0.8 \text{ V}</math>.</p>	I

### ■ Terminal Equivalent Circuits (continued)

Pin No.	Equivalent circuit	Description	I/O
15		<p><b>Latch:</b> Terminal for connecting the time constant setting capacitor for timer latch short-circuit protection circuit. The charge current <math>I_{CHG}</math> is about <math>-80 \mu\text{A}</math>.</p>	O
16		<p><b><math>V_{REF}</math>:</b> The output terminal for the reference voltage (<math>2.5 \text{ V typ.}</math>). Use it with a load current of <math>-1 \text{ mA}</math> or under. The terminal has a built-in short-circuit protection circuit, and the short-circuit current is <math>-20 \text{ mA typ.}</math> Use the terminal for setting the reference input of the error amplifier.</p>	O

■ Application Notes

[1] Main characteristics

Reference voltage temperature characteristics

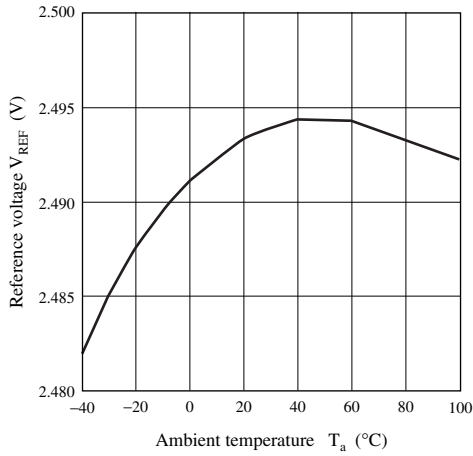

Maximum duty ratio temperature characteristics

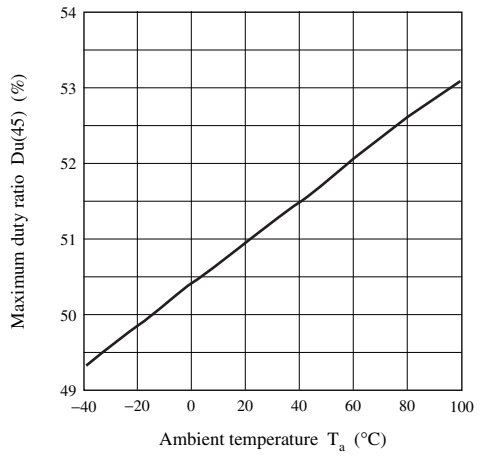

Output frequency temperature characteristics

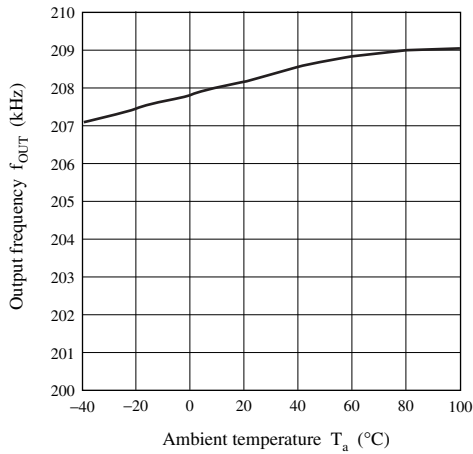

DTC pin voltage — Output duty ratio

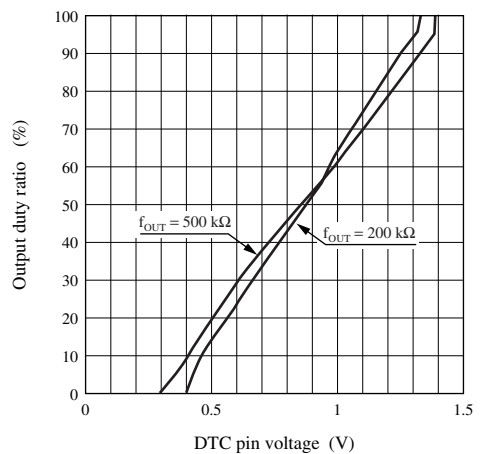

Output frequency characteristics

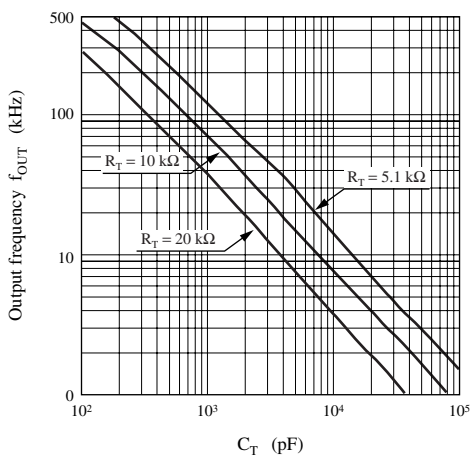

■ Application Notes (continued)

[2] Function descriptions

1. Reference voltage block

This block is composed of the band gap circuit, and outputs the temperature compensated 2.5 V reference voltage to the  $V_{REF}$  terminal. The reference voltage is stabilized when the supply voltage is 3.6 V or higher, and used as the operating power supply for the IC inside. It is possible to take out a load current of up to  $-3$  mA. Also, an overcurrent protection circuit is built in for the load, thereby protecting the IC from destruction when  $V_{REF}$  terminal is short circuited.

2. Triangular wave oscillation block

The triangular wave which swings from the wave peak of approximately 1.4 V to the wave bottom of approximately 0.4 V will be generated by connecting a timing capacitor and a resistor to the CT terminal and RT terminal respectively. The oscillation frequency can be freely decided by the value of  $C_T$  and  $R_T$  connected externally. The triangular wave is connected with the inverted input of PWM comparator of the IC inside.

3. Error amplifier block

This block detects the output voltage of DC-DC converter, and inputs the signal amplified by the pnp transistor input type differential amplifier to the PWM comparator.

The common-mode input voltage range is  $-0.1$  V to 0.8 V, and is a voltage obtained by dividing the reference voltage with resistors.

Also, it is possible to perform the gain setting and the phase compensation arbitrarily by connecting the feedback resistor and the capacitor from the error amplifier output terminal to the inverted input terminal.

The output voltage  $V_{OUT}$ , if positive, is obtained by connecting the resistor-divided reference voltage to the noninverted input terminal as shown in figure 1. 1), and the output voltage  $V_{OUT}$ , if negative, is obtained by connecting to the inverted input terminal as shown in figure 1. 2). The output voltages in each of these cases are given in the following equations.

$$V_{OUT1} = V_{IN} \times \frac{R1 + R2}{R2}$$

$$V_{IN+} = V_{REF} \times \frac{R1 + R2}{R2}$$

$$V_{OUT1} = -(V_{REF} - V_{IN-1}) \times \frac{R3 + R4}{R3} + V_{REF}$$

$$V_{IN-1} = V_{REF} \times \frac{R2}{R1 + R2}$$

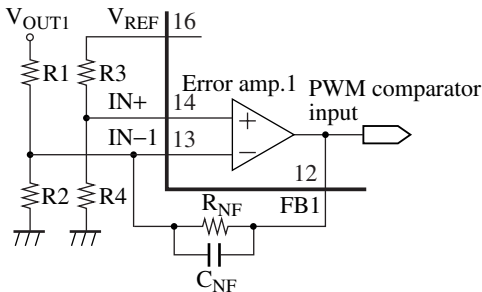

1) Positive output

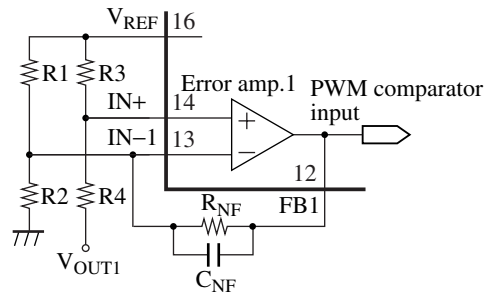

2) Negative output

Figure 1. Connection method of error amplifier 1

The output voltage of channel 2  $V_{OUT2}$  is exclusively for positive voltage output, and method of connection is as shown in figure 2.

$$V_{OUT2} = 0.75 \times \frac{R1 + R2}{R2}$$

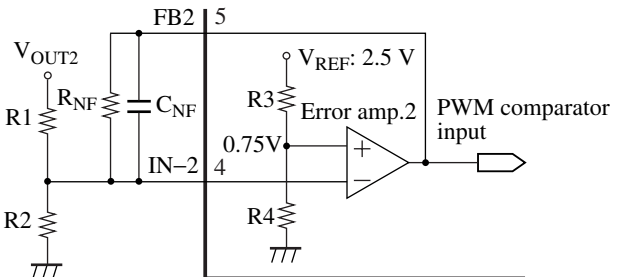

Figure 2. Connection method of error amplifier 2

## ■ Application Notes (continued)

### [2] Function descriptions (continued)

#### 4. Timer latch short-circuit protection circuit

This circuit protects the external main switching devices, switching diodes, choke coils, and etc. from destruction or deterioration if overload or short-circuit of power supply output lasts for a certain time.

The timer latch type short-circuit protection circuit detects the output level of each error amplifier, and when the output level of either one or both of the error amplifiers exceeds 1.85 V typical, the timer circuit is actuated, and initiates charging the external capacitor for protection enable.

If the output of the error amplifier does not return to a normal voltage range by the time when the voltage of this capacitor reaches 1.25 V, it sets the latch circuit, cuts off the output drive transistor, and sets the dead time to 100%.

#### 5. Low input voltage malfunction prevention circuit (U.V.L.O.)

This circuit protects the system from destruction or deterioration due to control malfunction caused by the supply voltage reduction in the transient state of power on or off.

The low input voltage malfunction prevention circuit detects the internal reference voltage according to the supply voltage level, and cuts off the output drive transistor by resetting the latch circuit, thereby setting the dead-time to 100% and keeping the latch terminal low.

#### 6. PWM comparator block

The PWM comparators, each has one inverted input, and two noninverted inputs, and controls the on-period of output pulse in accordance with the input voltage. It turns on the output transistor during the period when the triangular wave of  $C_T$  terminal is lower than either the error amplifier output voltage or the DTC terminal voltage.

The dead-time is set by the addition of a resistor between the DTC terminal and GND. By the addition of a capacitor in parallel with the external resistor  $R_{DTC}$ , the soft start function which gradually extends the on-period of the output pulse by the RC time constant when the power supply is turned on starts to work.

#### 7. Output block

The output drive transistor is of open-collector type output connected in Darlington circuit of emitter common GND. The breakdown voltage of the collector output terminal is 34 V and it is possible to obtain up to 100 mA output current.

#### 8. Remote circuit

It is possible to switch on/off the IC control by an external control signal. When the on/off terminal voltage is lowered to a value below approximately 0.8 V, the internal reference voltage goes down, thereby the IC control is stopped and the circuit current is decreased to 5  $\mu$ A or less. When the on/off terminal voltage is increased to a value higher than approximately 2.0 V, the internal reference voltage raises and the control operation is started.

### [3] The time constant setting method for timer latch type short-circuit protection circuit

Figure 3 shows the block diagram of the protection latch circuit. The comparator for short-circuit protection compares the output voltage of error amplifier  $V_{FB}$  with the reference voltage (1.85 V) at all the time. When the load conditions of DC-DC converter output is stabilized, there is no fluctuation of error amplifier output, and the short-circuit protection comparator also keeps the balance. At this moment, the switch SW1 will be in the off state, and the latch terminal voltage will be kept at approximately 0.9 V typical.

When the load conditions suddenly change, and high-level signal (1.85 V typical or higher) is inputted from the error amplifier to the noninverted input of the short-circuit protection comparator, the short-circuit protection comparator outputs the high-level signal. This signal turns on the switch SW1, and the charging to the capacitor  $C_S$  connected externally to the latch terminal is started with a current of 80  $\mu$ A typical.

When the external capacitor  $C_S$  is charged up to approximately 1.25 V typical, the latch circuit is set and the under-voltage lock-out circuit (U.V.L.O.) is enabled, thereby the output drive transistor is cut off and the dead-time is set to 100%.

Once the under-voltage lock-out circuit (U.V.L.O.) is enabled, the latch circuit will not be reset unless the power supply is switched off.

■ Application Notes (continued)

[3] The time constant setting method for timer latch type short-circuit protection circuit (continued)

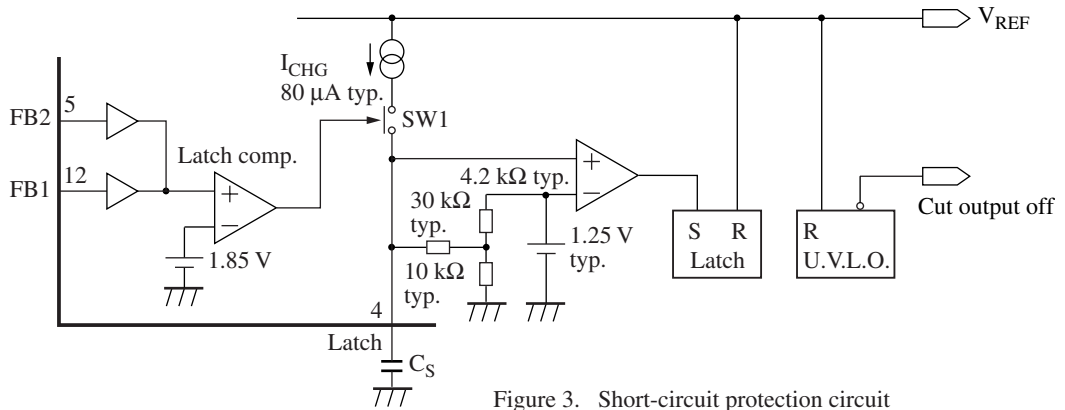

Figure 3. Short-circuit protection circuit

When the power supply is turned on, the output is considered to be short-circuited state, so that the error amplifier output becomes high-level, then SW1 becomes on state and the charging starts. It is necessary to set the external capacitor so as to start up the DC-DC converter output voltage before setting the latch circuit in the later stage.

Especially, pay attention to the delay of the start-up time when applying the soft-start.

[4] Explanation of unlatch protection circuit operation

Figure 4 shows the block diagram of the unlatch protection circuit. It is possible to suppress FB terminal, the error amplifier output terminal of the channel, to low by setting DTC terminal to 0.12 V or less through external signal. Consequently, by controlling the DTC terminal voltage, it is possible to operate only one channel, or to start and stop each channel in any required sequence.

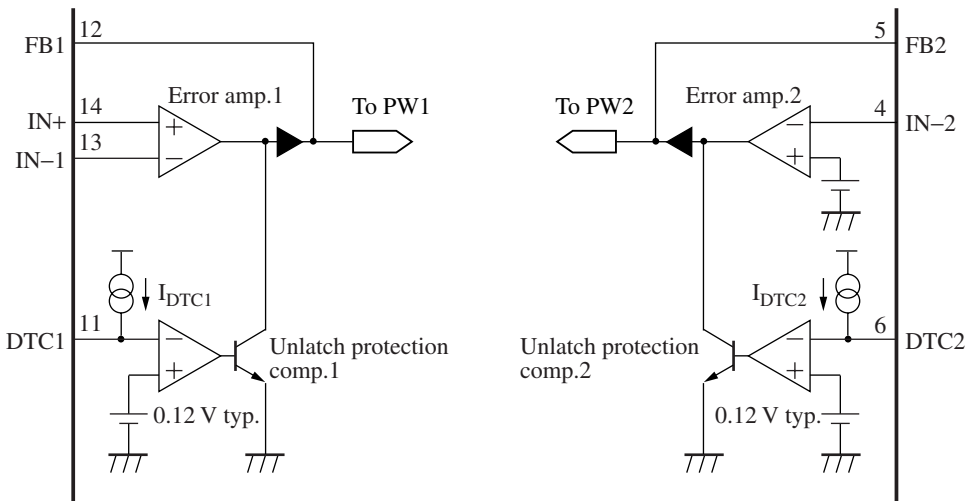

Figure 4. Unlatch protection circuit

■ Application Notes (continued)

[5] Triangular wave oscillation circuit

- Oscillation frequency setting method

The waveform of triangular wave oscillation is obtained by charging and discharging of the constant current  $I_O$  from the external timing capacitor  $C_T$  which is connected to CT terminal. The constant current is set by the externally attached timing resistor  $R_T$ .

The peak value of the wave  $V_{CTH}$  and the trough value of the wave  $V_{CTL}$  are fixed at approximately 1.4 V typical and 0.4 V typical respectively.

The oscillation frequency  $f_{OSC}$  is obtained by the following formula;

$$f_{OSC} \text{ (typ.)} = \frac{1}{t_1 + t_2} = \frac{I_O}{2 \times C_T \times (V_{CTH} - V_{CTL})}$$

Where  $I_O = 2 \times \frac{V_{RT}}{R_T} = 2 \times \frac{0.67}{R_T}$

Because  $V_{CTH} - V_{CTL} = 1 \text{ V}$

$$f_{OSC} \text{ (typ.)} = \frac{0.67}{C_T \times R_T} \text{ [Hz]}$$

The output frequency  $f_{OUT}$  is equal to  $f_{OSC}$  since it is PWM-controlled.

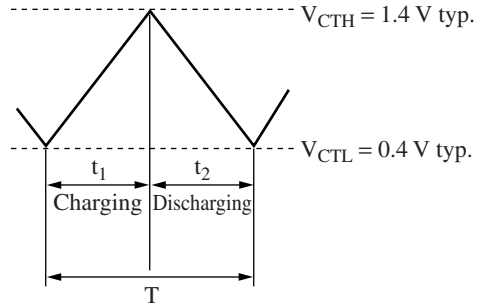

Figure 5. Triangular wave oscillation waveform

[6] Dead-time (maximum duty) setting method

The setting of the dead-time is conducted by adjusting the DTC terminal voltage  $V_{DTC}$  as shown in figure 6. Since the DTC terminal provides a constant current output through the resistor  $R_T$ ,  $V_{DTC}$  is adjusted by attaching the external resistor  $R_{DTC}$ .

The output duty ratio  $Du$  and the DTC terminal voltage  $V_{DTC}$  are expressed by the following formula. When the oscillation frequency  $f_{OSC}$  is 200 kHz, the output duty ratio is 0% at  $V_{DTC} = 0.42 \text{ V}$ , and 100% at  $V_{DTC} = 1.35 \text{ V}$ .

Pay attention to the peak value and the trough value of triangular wave because the overshoot and undershoot voltages depend on the frequency.

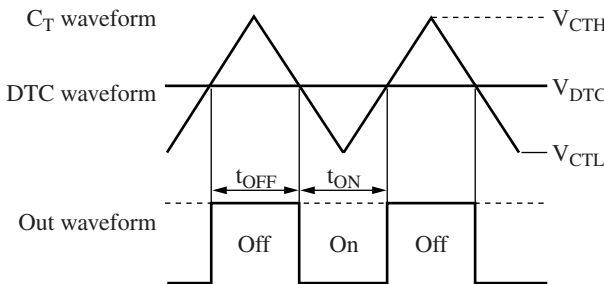

$$Du \text{ (typ.)} = \frac{t_{ON}}{t_{ON} + t_{OFF}} \times 100 \text{ [%]}$$

$$= \frac{V_{CTH} - V_{DTC}}{V_{CTH} - V_{CTL}} \times 100 \text{ [%]}$$

$$V_{DTC} \text{ (typ.)} = I_{DTC} \times R_{DTC}$$

$$= V_{RT} \times \frac{R_{DTC}}{R_T} \times 1.04 \text{ [V]}$$

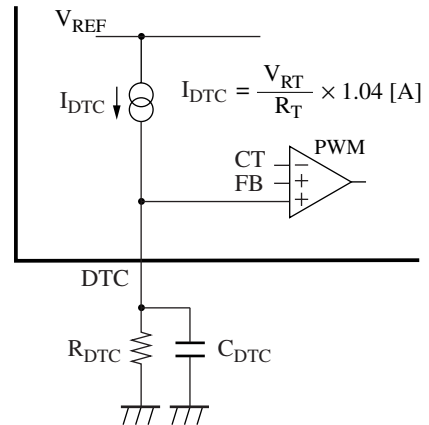

ex.) When  $f_{OSC} = 200 \text{ kHz}$  ( $R_T = 20 \text{ k}\Omega$ ,  $C_T = 150 \text{ pF}$ ),  
 $V_{CTH} \approx 1.4 \text{ V (typ.)}$   $V_{CTL} \approx 0.4 \text{ V (typ.)}$   
 $V_{RT} \approx 0.67 \text{ V (typ.)}$   $I_{DTC} \approx 35 \mu\text{A (typ.)}$

Figure 6. Dead-time setting method

When the capacitor  $C_{DTC}$  is added in parallel with the external resistor  $R_{DTC}$ , the soft start function gradually extends the on-period of the output pulse when the power supply is turned on. This prevents the overshoot of the DC-DC converter output.

■ Application Notes (continued)

[7] Timing chart

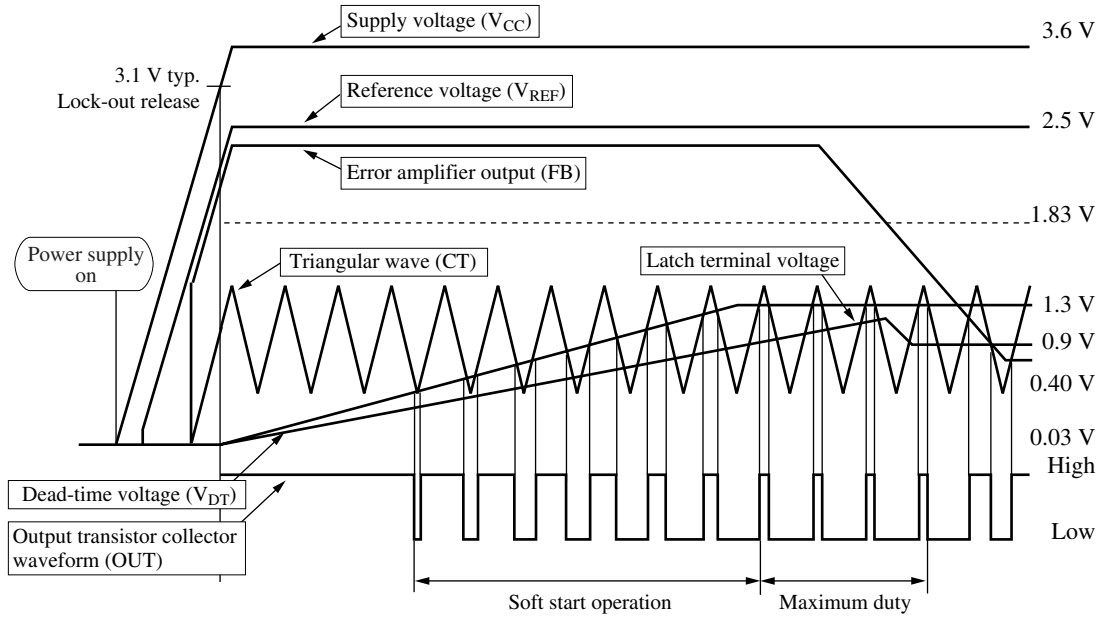

Figure 7. Operation waveform of PWM comparator

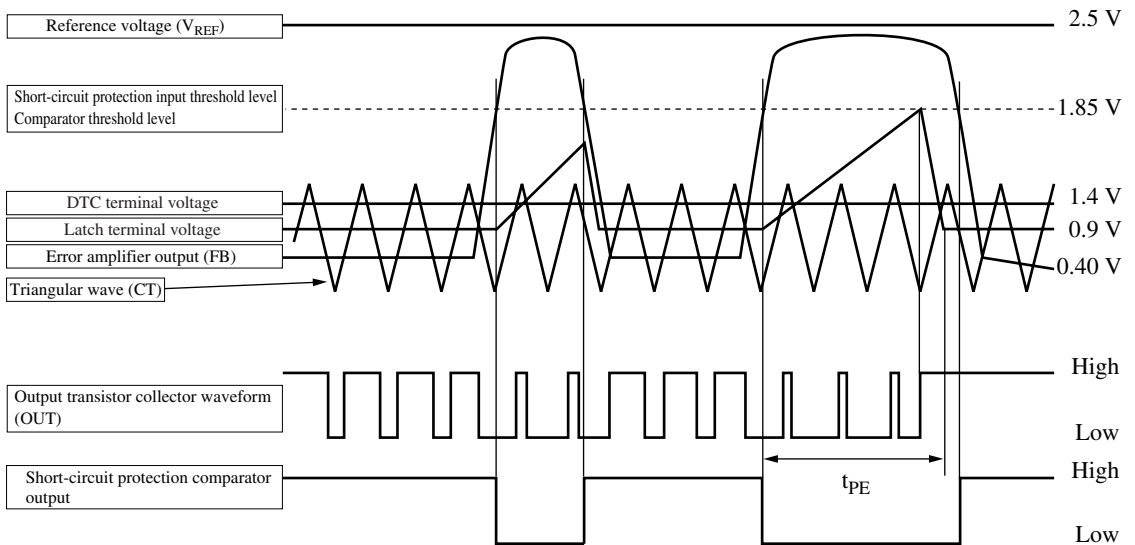
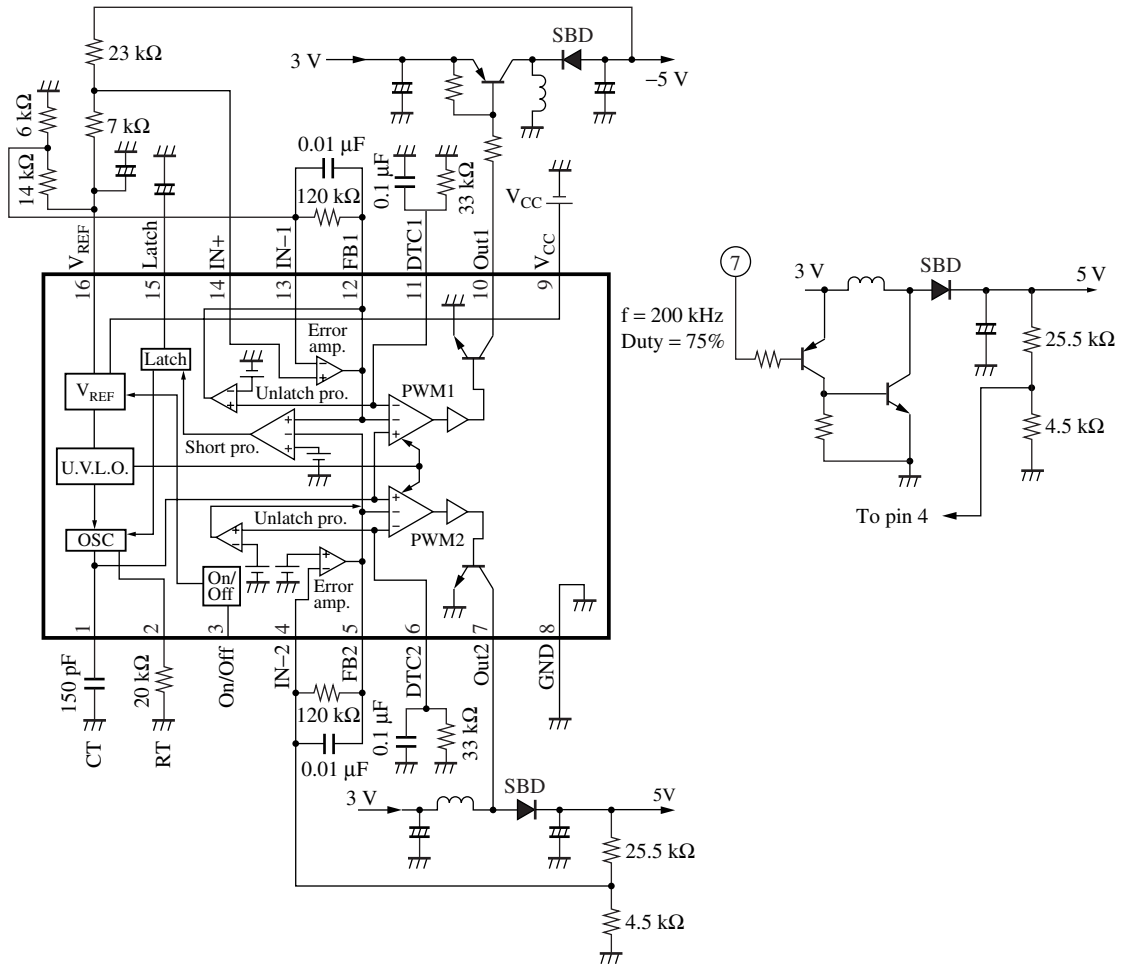

Figure 8. Operation waveform of short-circuit protection

■ Application Circuit Examples

- Application circuit example 1



■ Application Circuit Examples

- Application circuit example 2

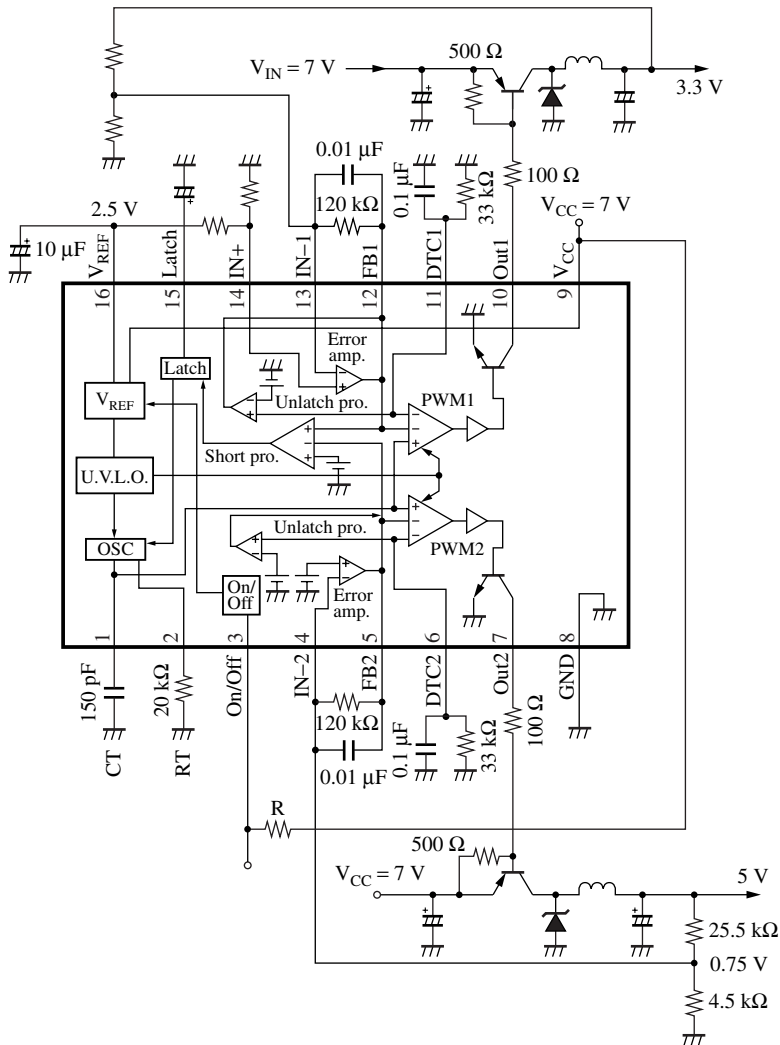

■ New Package Dimensions (Unit: mm)

- SOP016-P-0225E (Lead-free package)

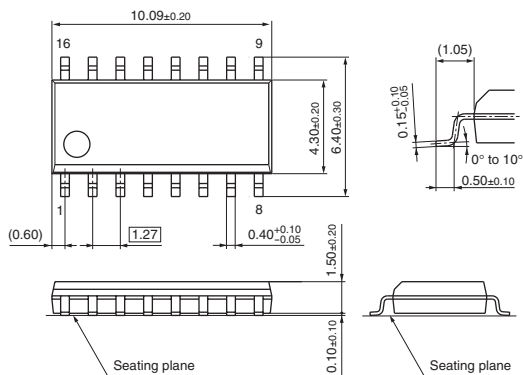

## Request for your special attention and precautions in using the technical information and semiconductors described in this material

- (1) An export permit needs to be obtained from the competent authorities of the Japanese Government if any of the products or technologies described in this material and controlled under the "Foreign Exchange and Foreign Trade Law" is to be exported or taken out of Japan.
- (2) The technical information described in this material is limited to showing representative characteristics and applied circuit examples of the products. It does not constitute the warranting of industrial property, the granting of relative rights, or the granting of any license.
- (3) The products described in this material are intended to be used for standard applications or general electronic equipment (such as office equipment, communications equipment, measuring instruments and household appliances).  
Consult our sales staff in advance for information on the following applications:
  - Special applications (such as for airplanes, aerospace, automobiles, traffic control equipment, combustion equipment, life support systems and safety devices) in which exceptional quality and reliability are required, or if the failure or malfunction of the products may directly jeopardize life or harm the human body.
  - Any applications other than the standard applications intended.
- (4) The products and product specifications described in this material are subject to change without notice for reasons of modification and/or improvement. At the final stage of your design, purchasing, or use of the products, therefore, ask for the most up-to-date Product Standards in advance to make sure that the latest specifications satisfy your requirements.
- (5) When designing your equipment, comply with the guaranteed values, in particular those of maximum rating, the range of operating power supply voltage and heat radiation characteristics. Otherwise, we will not be liable for any defect which may arise later in your equipment.  
Even when the products are used within the guaranteed values, redundant design is recommended, so that such equipment may not violate relevant laws or regulations because of the function of our products.
- (6) When using products for which dry packing is required, observe the conditions (including shelf life and after-unpacking standby time) agreed upon when specification sheets are individually exchanged.
- (7) No part of this material may be reprinted or reproduced by any means without written permission from our company.

## Please read the following notes before using the datasheets

- A. These materials are intended as a reference to assist customers with the selection of Panasonic semiconductor products best suited to their applications.  
Due to modification or other reasons, any information contained in this material, such as available product types, technical data, and so on, is subject to change without notice.  
Customers are advised to contact our semiconductor sales office and obtain the latest information before starting precise technical research and/or purchasing activities.
- B. Panasonic is endeavoring to continually improve the quality and reliability of these materials but there is always the possibility that further rectifications will be required in the future. Therefore, Panasonic will not assume any liability for any damages arising from any errors etc. that may appear in this material.
- C. These materials are solely intended for a customer's individual use.  
Therefore, without the prior written approval of Panasonic, any other use such as reproducing, selling, or distributing this material to a third party, via the Internet or in any other way, is prohibited.



LittleDiode supplies new, hard to find or obsolete electronic components and semiconductors all over the world.

With over two million different components listed you are sure to find the part you need.

Feel free to visit us today at our online store:

**[LittleDiode.com](http://LittleDiode.com)**

Looking forward to providing you with the best possible service.