

# AN7700, AN7700F, AN7700SP Series

## Low-dropout three-pin voltage regulator 1.2-A type

### ■ Overview

The AN7700, AN7700F, and AN7700SP series are stabilized constant-voltage power supplies with small difference between I/O voltages (0.5 V typ.). They are suitable for low-voltage, battery-driven equipment, and home appliances and industrial equipment with great fluctuation of the supply voltage.

The output voltage ranges:

For AN7700, AN7700F

3 V, 4 V, 5 V, 6 V, 7 V, 8 V, 9 V, 10 V, 12 V, 15 V,  
18 V, 20 V, and 24 V

For AN7700SP

3.3 V, 3.5 V, 5 V, 6 V, 7 V, 8 V, 9 V, 10 V, 12 V,  
and 15 V

### ■ Features

- Minimum I/O voltage difference: 0.5 V (typ.)
- On-chip overcurrent limiter
- On-chip thermal protection circuit
- On-chip inrush current protection circuit at the time of input voltage start-up
- On-chip input short-circuit protection circuit  
(When the input pin is short-circuited to the ground, the circuit between pins 1 and 3 is shut down to prevent current flow.)

### ■ Applications

- Power supply equipment

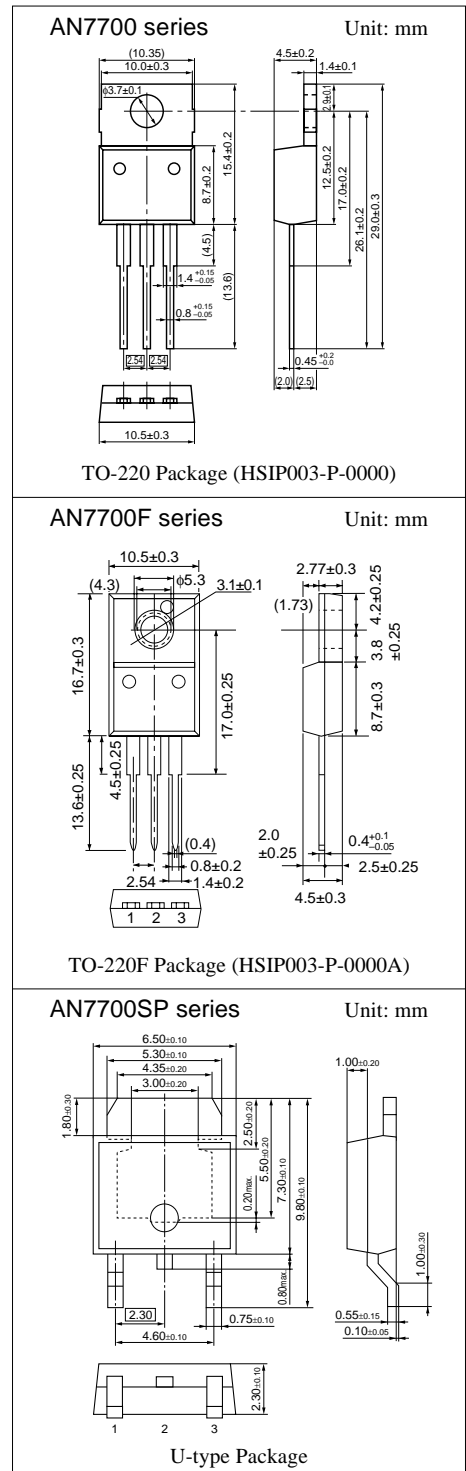

## ■ Block Diagram

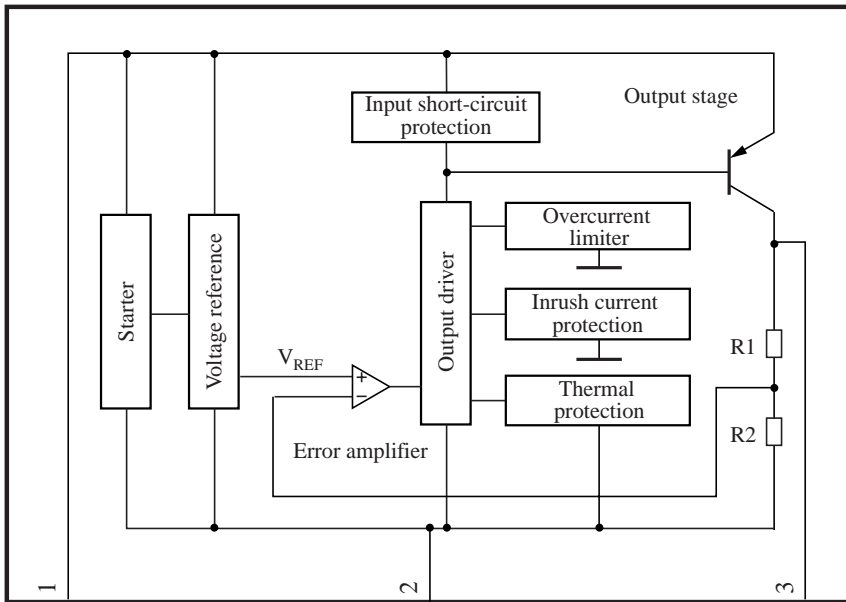

## ■ Pin Descriptions

Pin No.	Description
1	Input pin (In)
2	Ground pin (COM)
3	Output pin (Out)

## ■ Absolute Maximum Ratings at $T_a = 25^\circ\text{C}$

Parameter	Symbol	Rating	Unit
Supply voltage <sup>*2</sup>	$V_{IN}$	30	V
Supply current <sup>*3</sup>	$I_{IN}$	2.4	A
Power dissipation <sup>*4</sup>	AN7700 series	15	W
	AN7700F series	10.25	
	AN7700SP series	5.0	
Operating ambient temperature <sup>*1</sup>	$T_{opr}$	-30 to +85	$^\circ\text{C}$
Storage temperature <sup>*1</sup>	$T_{stg}$	-55 to +150	$^\circ\text{C}$

Note) \*1: Expect for the operating ambient temperature, and storage temperature, all ratings are for  $T_a = 25^\circ\text{C}$ .

\*2: At the application of  $V_{IN} = 30\text{ V}$ , the overvoltage protection may be operated by the ASO protection circuit, leading to the output shut down.

\*3: The current value does not exceed this criterion because of the on-chip current limiter.

\*4: The internal circuit shuts off the output when  $T_j \geq 150^\circ\text{C}$  (designed value). The relationship between the IC power dissipation and ambient temperature shall conform to the derating curve (■ Characteristic curve chart  $P_D - T_a$ ).

■ Recommended Operating Conditions at  $I_{OUT} = 500 \text{ mA}$ ,  $T_a = 25^\circ\text{C}$ 

Part No.	Output voltage	Operating supply voltage range ( $V_{IN}$ )	Unit
AN7703/F	3	4 to 14	V
AN77033SP	3.3	4.3 to 14	V
AN77035SP	3.5	4.5 to 14	V
AN7704/F	4	5 to 15	V
AN7705/F/SP	5	6 to 16	V
AN7706/F/SP	6	7 to 17	V
AN7707/F/SP	7	8 to 18	V
AN7708/F/SP	8	9 to 19	V
AN7709/F/SP	9	10 to 20	V
AN7710/F/SP	10	11 to 21	V
AN7712/F/SP	12	13 to 23	V
AN7715/F/SP	15	16.5 to 26.5	V
AN7718/F	18	19.5 to 29.5	V
AN7720/F	20	21.5 to 29.5	V
AN7724/F	24	25.5 to 29.5	V

■ Electrical Characteristics at  $T_a = 25^\circ\text{C}$

• AN7703/F (3-V type)

Parameter	Symbol	Conditions	Min	Typ	Max	Unit
Output voltage	$V_{\text{OUT}}$	$V_{\text{IN}} = 4 \text{ V}$ , $I_{\text{OUT}} = 500 \text{ mA}$ , $T_j = 25^\circ\text{C}$	2.91	3.00	3.09	V
Line regulation	$\text{REG}_{\text{IN}}$	$V_{\text{IN}} = 4 \text{ V to } 14 \text{ V}$ , $I_{\text{OUT}} = 500 \text{ mA}$ , $T_j = 25^\circ\text{C}$	—	3	30	mV
Load regulation	$\text{REG}_{\text{LOA}}$	$V_{\text{IN}} = 4 \text{ V}$ , $I_{\text{OUT}} = 0 \text{ mA to } 1\,200 \text{ mA}$ , $T_j = 25^\circ\text{C}$	—	15	60	mV
Input dependency of bias current	$\Delta I_{\text{Bias(IN)}}$	$V_{\text{IN}} = 4 \text{ V to } 14 \text{ V}$ , $I_{\text{OUT}} = 500 \text{ mA}$ , $T_j = 25^\circ\text{C}$	—	1	10	mA
Load dependency of bias current	$\Delta I_{\text{Bias(LOA)}}$	$V_{\text{IN}} = 4 \text{ V}$ , $I_{\text{OUT}} = 0 \text{ mA to } 1\,200 \text{ mA}$ , $T_j = 25^\circ\text{C}$	—	10	50	mA
Bias current at no load	$I_{\text{Bias}}$	$V_{\text{IN}} = 4 \text{ V}$ , $I_{\text{OUT}} = 0 \text{ mA}$	—	2.6	5.0	mA
Bias current before the regulation starts	$I_{\text{rush}}$	$V_{\text{IN}} = 2.7 \text{ V}$ , $I_{\text{OUT}} = 0 \text{ mA}$	—	3	5	mA
Minimum I/O voltage difference 1	$V_{\text{DIF(min)1}}$	$V_{\text{IN}} = 3.5 \text{ V}$ , $I_{\text{OUT}} = 500 \text{ mA}$ , $T_j = 25^\circ\text{C}$	—	0.4	0.6	V
Minimum I/O voltage difference 2	$V_{\text{DIF(min)2}}$	$V_{\text{IN}} = 3.5 \text{ V}$ , $I_{\text{OUT}} = 1\,200 \text{ mA}$ , $T_j = 25^\circ\text{C}$	—	0.5	1.0	V
Peak output current 1 *	$I_{\text{O(Peak)1}}$	$V_{\text{IN}} = 4 \text{ V}$ , $T_j = 25^\circ\text{C}$	1.2	1.8	2.4	A
Peak output current 2 *	$I_{\text{O(Peak)2}}$	$V_{\text{IN}} = 13 \text{ V}$ , $T_j = 25^\circ\text{C}$	1.0	1.5	2.0	A
Peak output current 3 *	$I_{\text{O(Peak)3}}$	$V_{\text{IN}} = 18 \text{ V}$ , $T_j = 25^\circ\text{C}$	0.5	1.0	1.5	A
Ripple rejection ratio	RR	$V_{\text{IN}} = 4 \text{ V to } 6 \text{ V}$ , $I_{\text{OUT}} = 100 \text{ mA}$ , $f = 120 \text{ Hz}$	54	74	—	dB

Note) \*: This current exceeds  $P_{\text{D(max)}}$  because it is a parameter during abnormal (overcurrent) operation. However, normally, it shall conform to the derating curve ( ■ Characteristic curve chart  $P_{\text{D}} - T_a$  ).

• Design reference data

Note) The characteristics listed below are theoretical values based on the IC design and are not guaranteed.

Parameter	Symbol	Conditions	Min	Typ	Max	Unit
Output short-circuit current	$I_{\text{O(Short)}}$	$V_{\text{IN}} = 30 \text{ V}$ , $T_j = 25^\circ\text{C}$ The load is shorted.	—	10	—	mA
Thermal protection operating temperature	$T_{\text{j(TH)}}$	$V_{\text{IN}} = 4 \text{ V}$	—	150	—	$^\circ\text{C}$
Output voltage temperature coefficient	a	$V_{\text{IN}} = 5 \text{ V}$ , $T_j = 25^\circ\text{C to } 125^\circ\text{C}$	—	-40	—	ppm/ $^\circ\text{C}$

■ Electrical Characteristics at  $T_a = 25^\circ\text{C}$  (continued)

• AN77033SP (3.3-V type)

Parameter	Symbol	Conditions	Min	Typ	Max	Unit
Output voltage	$V_{\text{OUT}}$	$V_{\text{IN}} = 4.3 \text{ V}$ , $I_{\text{OUT}} = 500 \text{ mA}$ , $T_j = 25^\circ\text{C}$	3.20	3.30	3.40	V
Line regulation	$\text{REG}_{\text{IN}}$	$V_{\text{IN}} = 4.3 \text{ V}$ to $14.3 \text{ V}$ , $I_{\text{OUT}} = 500 \text{ mA}$ , $T_j = 25^\circ\text{C}$	—	3	35	mV
Load regulation	$\text{REG}_{\text{LOA}}$	$V_{\text{IN}} = 4.3 \text{ V}$ , $I_{\text{OUT}} = 0 \text{ mA}$ to $1\,200 \text{ mA}$ , $T_j = 25^\circ\text{C}$	—	15	70	mV
Input dependency of bias current	$\Delta I_{\text{Bias(IN)}}$	$V_{\text{IN}} = 4.3 \text{ V}$ to $14.3 \text{ V}$ , $I_{\text{OUT}} = 500 \text{ mA}$ , $T_j = 25^\circ\text{C}$	—	1	10	mA
Load dependency of bias current	$\Delta I_{\text{Bias(LOA)}}$	$V_{\text{IN}} = 4.3 \text{ V}$ , $I_{\text{OUT}} = 0 \text{ mA}$ to $1\,200 \text{ mA}$ , $T_j = 25^\circ\text{C}$	—	10	50	mA
Bias current at no load	$I_{\text{Bias}}$	$V_{\text{IN}} = 4.3 \text{ V}$ , $I_{\text{OUT}} = 0 \text{ mA}$	—	2.6	5.0	mA
Bias current before the regulation starts	$I_{\text{rush}}$	$V_{\text{IN}} = 3.0 \text{ V}$ , $I_{\text{OUT}} = 0 \text{ mA}$	—	3	5	mA
Minimum I/O voltage difference 1	$V_{\text{DIF(min)1}}$	$V_{\text{IN}} = 3.7 \text{ V}$ , $I_{\text{OUT}} = 500 \text{ mA}$ , $T_j = 25^\circ\text{C}$	—	0.4	0.6	V
Minimum I/O voltage difference 2	$V_{\text{DIF(min)2}}$	$V_{\text{IN}} = 3.7 \text{ V}$ , $I_{\text{OUT}} = 1\,200 \text{ mA}$ , $T_j = 25^\circ\text{C}$	—	0.5	1.0	V
Peak output current 1 *	$I_{\text{O(Peak)1}}$	$V_{\text{IN}} = 4.3 \text{ V}$ , $T_j = 25^\circ\text{C}$	1.2	1.8	2.4	A
Ripple rejection ratio	RR	$V_{\text{IN}} = 4.3 \text{ V}$ to $8.0 \text{ V}$ , $I_{\text{OUT}} = 100 \text{ mA}$ , $f = 120 \text{ Hz}$	53	74	—	dB

Note) \*: This current exceeds  $P_{\text{D(max)}}$  because it is a parameter during abnormal (overcurrent) operation. However, normally, it shall conform to the derating curve ( ■ Characteristic curve chart  $P_{\text{D}} - T_a$  ).

• Design reference data

Note) The characteristics listed below are theoretical values based on the IC design and are not guaranteed.

Parameter	Symbol	Conditions	Min	Typ	Max	Unit
Peak output current 2 *	$I_{\text{O(Peak)2}}$	$V_{\text{IN}} = 13.3 \text{ V}$ , $T_j = 25^\circ\text{C}$	—	1.5	—	A
Peak output current 3 *	$I_{\text{O(Peak)3}}$	$V_{\text{IN}} = 18.3 \text{ V}$ , $T_j = 25^\circ\text{C}$	—	1.0	—	A
Output short-circuit current	$I_{\text{O(Short)}}$	$V_{\text{IN}} = 30 \text{ V}$ , $T_j = 25^\circ\text{C}$ The load is shorted.	—	10	—	mA
Thermal protection operating temperature	$T_{\text{j(TH)}}$	$V_{\text{IN}} = 4.3 \text{ V}$	—	150	—	$^\circ\text{C}$
Output voltage temperature coefficient	a	$V_{\text{IN}} = 4.3 \text{ V}$ , $T_j = 25^\circ\text{C}$ to $125^\circ\text{C}$	—	-40	—	ppm/ $^\circ\text{C}$

Note) \*: This current exceeds  $P_{\text{D(max)}}$  because it is a parameter during abnormal (overcurrent) operation. However, normally, it shall conform to the derating curve ( ■ Characteristic curve chart  $P_{\text{D}} - T_a$  ).

■ Electrical Characteristics at  $T_a = 25^\circ\text{C}$  (continued)

• AN77035SP (3.5-V type)

Parameter	Symbol	Conditions	Min	Typ	Max	Unit
Output voltage	$V_{\text{OUT}}$	$V_{\text{IN}} = 4.5\text{ V}$ , $I_{\text{OUT}} = 500\text{ mA}$ , $T_j = 25^\circ\text{C}$	3.39	3.50	3.61	V
Line regulation	$\text{REG}_{\text{IN}}$	$V_{\text{IN}} = 4.5\text{ V to } 14.5\text{ V}$ , $I_{\text{OUT}} = 500\text{ mA}$ , $T_j = 25^\circ\text{C}$	—	3	35	mV
Load regulation	$\text{REG}_{\text{LOA}}$	$V_{\text{IN}} = 4.5\text{ V}$ , $I_{\text{OUT}} = 0\text{ mA to } 1\ 200\text{ mA}$ , $T_j = 25^\circ\text{C}$	—	15	70	mV
Input dependency of bias current	$\Delta I_{\text{Bias(IN)}}$	$V_{\text{IN}} = 4.5\text{ V to } 14.5\text{ V}$ , $I_{\text{OUT}} = 500\text{ mA}$ , $T_j = 25^\circ\text{C}$	—	1	10	mA
Load dependency of bias current	$\Delta I_{\text{Bias(LOA)}}$	$V_{\text{IN}} = 4.5\text{ V}$ , $I_{\text{OUT}} = 0\text{ mA to } 1\ 200\text{ mA}$ , $T_j = 25^\circ\text{C}$	—	10	50	mA
Bias current at no load	$I_{\text{Bias}}$	$V_{\text{IN}} = 4.5\text{ V}$ , $I_{\text{OUT}} = 0\text{ mA}$	—	2.6	5.0	mA
Bias current before the regulation starts	$I_{\text{rush}}$	$V_{\text{IN}} = 3.2\text{ V}$ , $I_{\text{OUT}} = 0\text{ mA}$	—	3	5	mA
Minimum I/O voltage difference 1	$V_{\text{DIF(min)1}}$	$V_{\text{IN}} = 3.7\text{ V}$ , $I_{\text{OUT}} = 500\text{ mA}$ , $T_j = 25^\circ\text{C}$	—	0.4	0.6	V
Minimum I/O voltage difference 2	$V_{\text{DIF(min)2}}$	$V_{\text{IN}} = 3.7\text{ V}$ , $I_{\text{OUT}} = 1\ 200\text{ mA}$ , $T_j = 25^\circ\text{C}$	—	0.5	1.0	V
Peak output current 1 *	$I_{\text{O(Peak)1}}$	$V_{\text{IN}} = 4.5\text{ V}$ , $T_j = 25^\circ\text{C}$	1.2	1.8	2.4	A
Ripple rejection ratio	RR	$V_{\text{IN}} = 4.5\text{ V to } 8.0\text{ V}$ , $I_{\text{OUT}} = 100\text{ mA}$ , $f = 120\text{ Hz}$	53	74	—	dB

Note) \*: This current exceeds  $P_{\text{D(max)}}$  because it is a parameter during abnormal (overcurrent) operation. However, normally, it shall conform to the derating curve ( ■ Characteristic curve chart  $P_{\text{D}} - T_a$  ).

• Design reference data

Note) The characteristics listed below are theoretical values based on the IC design and are not guaranteed.

Parameter	Symbol	Conditions	Min	Typ	Max	Unit
Peak output current 2 *	$I_{\text{O(Peak)2}}$	$V_{\text{IN}} = 13.5\text{ V}$ , $T_j = 25^\circ\text{C}$	—	1.5	—	A
Peak output current 3 *	$I_{\text{O(Peak)3}}$	$V_{\text{IN}} = 18.5\text{ V}$ , $T_j = 25^\circ\text{C}$	—	1.0	—	A
Output short-circuit current	$I_{\text{O(Short)}}$	$V_{\text{IN}} = 30\text{ V}$ , $T_j = 25^\circ\text{C}$ The load is shorted.	—	10	—	mA
Thermal protection operating temperature	$T_{\text{j(TH)}}$	$V_{\text{IN}} = 4.5\text{ V}$	—	150	—	$^\circ\text{C}$
Output voltage temperature coefficient	a	$V_{\text{IN}} = 4.5\text{ V}$ , $T_j = 25^\circ\text{C to } 125^\circ\text{C}$	—	-40	—	ppm/ $^\circ\text{C}$

Note) \*: This current exceeds  $P_{\text{D(max)}}$  because it is a parameter during abnormal (overcurrent) operation. However, normally, it shall conform to the derating curve ( ■ Characteristic curve chart  $P_{\text{D}} - T_a$  ).

■ Electrical Characteristics at  $T_a = 25^\circ\text{C}$  (continued)

• AN7704/F (4-V type)

Parameter	Symbol	Conditions	Min	Typ	Max	Unit
Output voltage	$V_{\text{OUT}}$	$V_{\text{IN}} = 5\text{ V}$ , $I_{\text{OUT}} = 500\text{ mA}$ , $T_j = 25^\circ\text{C}$	3.88	4.00	4.12	V
Line regulation	$\text{REG}_{\text{IN}}$	$V_{\text{IN}} = 5\text{ V to } 15\text{ V}$ , $I_{\text{OUT}} = 500\text{ mA}$ , $T_j = 25^\circ\text{C}$	—	4	40	mV
Load regulation	$\text{REG}_{\text{LOA}}$	$V_{\text{IN}} = 5\text{ V}$ , $I_{\text{OUT}} = 0\text{ mA to } 1\ 200\text{ mA}$ , $T_j = 25^\circ\text{C}$	—	20	80	mV
Input dependency of bias current	$\Delta I_{\text{Bias(IN)}}$	$V_{\text{IN}} = 5\text{ V to } 15\text{ V}$ , $I_{\text{OUT}} = 500\text{ mA}$ , $T_j = 25^\circ\text{C}$	—	1.0	10	mA
Load dependency of bias current	$\Delta I_{\text{Bias(LOA)}}$	$V_{\text{IN}} = 5\text{ V}$ , $I_{\text{OUT}} = 0\text{ mA to } 1\ 200\text{ mA}$ , $T_j = 25^\circ\text{C}$	—	10	50	mA
Bias current at no load	$I_{\text{Bias}}$	$V_{\text{IN}} = 5\text{ V}$ , $I_{\text{OUT}} = 0\text{ mA}$	—	2.6	5.0	mA
Bias current before the regulation starts	$I_{\text{rush}}$	$V_{\text{IN}} = 3.6\text{ V}$ , $I_{\text{OUT}} = 0\text{ mA}$	—	3	5	mA
Minimum I/O voltage difference 1	$V_{\text{DIF(min)1}}$	$V_{\text{IN}} = 3.6\text{ V}$ , $I_{\text{OUT}} = 500\text{ mA}$ , $T_j = 25^\circ\text{C}$	—	0.4	0.6	V
Minimum I/O voltage difference 2	$V_{\text{DIF(min)2}}$	$V_{\text{IN}} = 3.6\text{ V}$ , $I_{\text{OUT}} = 1\ 200\text{ mA}$ , $T_j = 25^\circ\text{C}$	—	0.5	1.0	V
Peak output current 1 *	$I_{\text{O(Peak)1}}$	$V_{\text{IN}} = 5\text{ V}$ , $T_j = 25^\circ\text{C}$	1.2	1.8	2.4	A
Peak output current 2 *	$I_{\text{O(Peak)2}}$	$V_{\text{IN}} = 14\text{ V}$ , $T_j = 25^\circ\text{C}$	—	1.5	—	A
Peak output current 3 *	$I_{\text{O(Peak)3}}$	$V_{\text{IN}} = 19\text{ V}$ , $T_j = 25^\circ\text{C}$	—	1.0	—	A
Ripple rejection ratio	RR	$V_{\text{IN}} = 5\text{ V to } 7\text{ V}$ , $I_{\text{OUT}} = 100\text{ mA}$ , $f = 120\text{ Hz}$	52	72	—	dB

Note) \*: This current exceeds  $P_{\text{D(max)}}$  because it is a parameter during abnormal (overcurrent) operation. However, normally, it shall conform to the derating curve ( ■ Characteristic curve chart  $P_{\text{D}} - T_a$  ).

• Design reference data

Note) The characteristics listed below are theoretical values based on the IC design and are not guaranteed.

Parameter	Symbol	Conditions	Min	Typ	Max	Unit
Output short-circuit current	$I_{\text{O(Short)}}$	$V_{\text{IN}} = 30\text{ V}$ , $T_j = 25^\circ\text{C}$ The load is shorted.	—	10	—	mA
Thermal protection operating temperature	$T_{\text{j(TH)}}$	$V_{\text{IN}} = 5\text{ V}$	—	150	—	$^\circ\text{C}$
Output voltage temperature coefficient	a	$V_{\text{IN}} = 5\text{ V}$ , $T_j = 25^\circ\text{C to } 12^\circ\text{C}$	—	-40	—	ppm/ $^\circ\text{C}$

■ Electrical Characteristics at  $T_a = 25^\circ\text{C}$  (continued)

• AN7705/F/SP (5-V type)

Parameter	Symbol	Conditions	Min	Typ	Max	Unit
Output voltage	$V_{\text{OUT}}$	$V_{\text{IN}} = 6\text{ V}$ , $I_{\text{OUT}} = 500\text{ mA}$ , $T_j = 25^\circ\text{C}$	4.85	5.00	5.15	V
Line regulation	$\text{REG}_{\text{IN}}$	$V_{\text{IN}} = 6\text{ V to } 16\text{ V}$ , $I_{\text{OUT}} = 500\text{ mA}$ , $T_j = 25^\circ\text{C}$	—	5	50	mV
Load regulation	$\text{REG}_{\text{LOA}}$	$V_{\text{IN}} = 6\text{ V}$ , $I_{\text{OUT}} = 0\text{ mA to } 1\ 200\text{ mA}$ , $T_j = 25^\circ\text{C}$	—	25	100	mV
Input dependency of bias current	$\Delta I_{\text{Bias(IN)}}$	$V_{\text{IN}} = 6\text{ V to } 16\text{ V}$ , $I_{\text{OUT}} = 500\text{ mA}$ , $T_j = 25^\circ\text{C}$	—	1	10	mA
Load dependency of bias current	$\Delta I_{\text{Bias(LOA)}}$	$V_{\text{IN}} = 6\text{ V}$ , $I_{\text{OUT}} = 0\text{ mA to } 1\ 200\text{ mA}$ , $T_j = 25^\circ\text{C}$	—	10	50	mA
Bias current at no load	$I_{\text{Bias}}$	$V_{\text{IN}} = 6\text{ V}$ , $I_{\text{OUT}} = 0\text{ mA}$	—	2.6	5	mA
Bias current before the regulation starts	$I_{\text{rush}}$	$V_{\text{IN}} = 4.5\text{ V}$ , $I_{\text{OUT}} = 0\text{ mA}$	—	3	5	mA
Minimum I/O voltage difference 1	$V_{\text{DIF(min)1}}$	$V_{\text{IN}} = 4.5\text{ V}$ , $I_{\text{OUT}} = 500\text{ mA}$ , $T_j = 25^\circ\text{C}$	—	0.4	0.6	V
Minimum I/O voltage difference 2	$V_{\text{DIF(min)2}}$	$V_{\text{IN}} = 4.5\text{ V}$ , $I_{\text{OUT}} = 1\ 200\text{ mA}$ , $T_j = 25^\circ\text{C}$	—	0.5	1.0	V
Peak output current 1 *	$I_{\text{O(Peak)1}}$	$V_{\text{IN}} = 6\text{ V}$ , $T_j = 25^\circ\text{C}$	1.2	1.8	2.4	A
Peak output current 2 * (Excluding the SP type)	$I_{\text{O(Peak)2}}$	$V_{\text{IN}} = 15\text{ V}$ , $T_j = 25^\circ\text{C}$	1.0	1.5	2.0	A
Peak output current 3 * (Excluding the SP type)	$I_{\text{O(Peak)3}}$	$V_{\text{IN}} = 20\text{ V}$ , $T_j = 25^\circ\text{C}$	0.5	1.0	1.5	A
Ripple rejection ratio	RR	$V_{\text{IN}} = 6\text{ V to } 8\text{ V}$ , $I_{\text{OUT}} = 100\text{ mA}$ , $f = 120\text{ Hz}$	50	70	—	dB

Note) \*: This current exceeds  $P_{\text{D(max)}}$  because it is a parameter during abnormal (overcurrent) operation. However, normally, it shall conform to the derating curve ( ■ Characteristic curve chart  $P_{\text{D}} - T_a$  ).

• Design reference data

Note) The characteristics listed below are theoretical values based on the IC design and are not guaranteed.

Parameter	Symbol	Conditions	Min	Typ	Max	Unit
Peak output current 2 * (Only for the SP type)	$I_{\text{O(Peak)2}}$	$V_{\text{IN}} = 15\text{ V}$ , $T_j = 25^\circ\text{C}$	—	1.5	—	A
Peak output current 3 * (Only for the SP type)	$I_{\text{O(Peak)3}}$	$V_{\text{IN}} = 20\text{ V}$ , $T_j = 25^\circ\text{C}$	—	1.0	—	A
Output short-circuit current	$I_{\text{O(Short)}}$	$V_{\text{IN}} = 30\text{ V}$ , $T_j = 25^\circ\text{C}$ The load is shorted.	—	10	—	mA
Thermal protection operating temperature	$T_{\text{j(TH)}}$	$V_{\text{IN}} = 6\text{ V}$	—	150	—	$^\circ\text{C}$
Output voltage temperature coefficient	a	$V_{\text{IN}} = 6\text{ V}$ , $T_j = 25^\circ\text{C to } 125^\circ\text{C}$	—	-40	—	ppm/ $^\circ\text{C}$

Note) \*: This current exceeds  $P_{\text{D(max)}}$  because it is a parameter during abnormal (overcurrent) operation. However, normally, it shall conform to the derating curve ( ■ Characteristic curve chart  $P_{\text{D}} - T_a$  ).

■ Electrical Characteristics at  $T_a = 25^\circ\text{C}$  (continued)

• AN7706/F/SP (6-V type)

Parameter	Symbol	Conditions	Min	Typ	Max	Unit
Output voltage	$V_{\text{OUT}}$	$V_{\text{IN}} = 7\text{ V}$ , $I_{\text{OUT}} = 500\text{ mA}$ , $T_j = 25^\circ\text{C}$	5.82	6.00	6.18	V
Line regulation	$\text{REG}_{\text{IN}}$	$V_{\text{IN}} = 7\text{ V to } 17\text{ V}$ , $I_{\text{OUT}} = 500\text{ mA}$ , $T_j = 25^\circ\text{C}$	—	6	60	mV
Load regulation	$\text{REG}_{\text{LOA}}$	$V_{\text{IN}} = 7\text{ V}$ , $I_{\text{OUT}} = 0\text{ mA to } 1\ 200\text{ mA}$ , $T_j = 25^\circ\text{C}$	—	30	120	mV
Input dependency of bias current	$\Delta I_{\text{Bias(IN)}}$	$V_{\text{IN}} = 7\text{ V to } 17\text{ V}$ , $I_{\text{OUT}} = 500\text{ mA}$ , $T_j = 25^\circ\text{C}$	—	1	10	mA
Load dependency of bias current	$\Delta I_{\text{Bias(LOA)}}$	$V_{\text{IN}} = 7\text{ V}$ , $I_{\text{OUT}} = 0\text{ mA to } 1\ 200\text{ mA}$ , $T_j = 25^\circ\text{C}$	—	10	50	mA
Bias current at no load	$I_{\text{Bias}}$	$V_{\text{IN}} = 7\text{ V}$ , $I_{\text{OUT}} = 0\text{ mA}$	—	2.6	5.0	mA
Bias current before the regulation starts	$I_{\text{rush}}$	$V_{\text{IN}} = 5.4\text{ V}$ , $I_{\text{OUT}} = 0\text{ mA}$	—	3	5	mA
Minimum I/O voltage difference 1	$V_{\text{DIF(min)1}}$	$V_{\text{IN}} = 5.4\text{ V}$ , $I_{\text{OUT}} = 500\text{ mA}$ , $T_j = 25^\circ\text{C}$	—	0.4	0.6	V
Minimum I/O voltage difference 2	$V_{\text{DIF(min)2}}$	$V_{\text{IN}} = 5.4\text{ V}$ , $I_{\text{OUT}} = 1\ 200\text{ mA}$ , $T_j = 25^\circ\text{C}$	—	0.5	1.0	V
Peak output current 1 *	$I_{\text{O(Peak)1}}$	$V_{\text{IN}} = 7\text{ V}$ , $T_j = 25^\circ\text{C}$	1.2	1.8	2.4	A
Peak output current 2 * (Excluding the SP type)	$I_{\text{O(Peak)2}}$	$V_{\text{IN}} = 16\text{ V}$ , $T_j = 25^\circ\text{C}$	1.0	1.5	2.0	A
Peak output current 3 * (Excluding the SP type)	$I_{\text{O(Peak)3}}$	$V_{\text{IN}} = 21\text{ V}$ , $T_j = 25^\circ\text{C}$	0.5	1.0	1.5	A
Ripple rejection ratio	RR	$V_{\text{IN}} = 7\text{ V to } 9\text{ V}$ , $I_{\text{OUT}} = 100\text{ mA}$ , $f = 120\text{ Hz}$	48	68	—	dB

Note) \*: This current exceeds  $P_{\text{D(max)}}$  because it is a parameter during abnormal (overcurrent) operation. However, normally, it shall conform to the derating curve ( ■ Characteristic curve chart  $P_{\text{D}} - T_a$  ).

• Design reference data

Note) The characteristics listed below are theoretical values based on the IC design and are not guaranteed.

Parameter	Symbol	Conditions	Min	Typ	Max	Unit
Peak output current 2 * (Only for the SP type)	$I_{\text{O(Peak)2}}$	$V_{\text{IN}} = 16\text{ V}$ , $T_j = 25^\circ\text{C}$	—	1.5	—	A
Peak output current 3 * (Only for the SP type)	$I_{\text{O(Peak)3}}$	$V_{\text{IN}} = 21\text{ V}$ , $T_j = 25^\circ\text{C}$	—	1.0	—	A
Output short-circuit current	$I_{\text{O(Short)}}$	$V_{\text{IN}} = 30\text{ V}$ , $T_j = 25^\circ\text{C}$ The load is shorted.	—	10	—	mA
Thermal protection operating temperature	$T_{\text{j(TH)}}$	$V_{\text{IN}} = 7\text{ V}$	—	150	—	$^\circ\text{C}$
Output voltage temperature coefficient	a	$V_{\text{IN}} = 7\text{ V}$ , $T_j = 25^\circ\text{C to } 125^\circ\text{C}$	—	-40	—	ppm/ $^\circ\text{C}$

Note) \*: This current exceeds  $P_{\text{D(max)}}$  because it is a parameter during abnormal (overcurrent) operation. However, normally, it shall conform to the derating curve ( ■ Characteristic curve chart  $P_{\text{D}} - T_a$  ).

■ Electrical Characteristics at  $T_a = 25^\circ\text{C}$  (continued)

• AN7707/F/SP (7-V type)

Parameter	Symbol	Conditions	Min	Typ	Max	Unit
Output voltage	$V_{\text{OUT}}$	$V_{\text{IN}} = 8\text{ V}$ , $I_{\text{OUT}} = 500\text{ mA}$ , $T_j = 25^\circ\text{C}$	6.79	7.00	7.21	V
Line regulation	$\text{REG}_{\text{IN}}$	$V_{\text{IN}} = 8\text{ V to } 18\text{ V}$ , $I_{\text{OUT}} = 500\text{ mA}$ , $T_j = 25^\circ\text{C}$	—	7	70	mV
Load regulation	$\text{REG}_{\text{LOA}}$	$V_{\text{IN}} = 8\text{ V}$ , $I_{\text{OUT}} = 0\text{ mA to } 1\ 200\text{ mA}$ , $T_j = 25^\circ\text{C}$	—	35	140	mV
Input dependency of bias current	$\Delta I_{\text{Bias(IN)}}$	$V_{\text{IN}} = 8\text{ V to } 18\text{ V}$ , $I_{\text{OUT}} = 500\text{ mA}$ , $T_j = 25^\circ\text{C}$	—	1	10	mA
Load dependency of bias current	$\Delta I_{\text{Bias(LOA)}}$	$V_{\text{IN}} = 8\text{ V}$ , $I_{\text{OUT}} = 0\text{ mA to } 1\ 200\text{ mA}$ , $T_j = 25^\circ\text{C}$	—	10	50	mA
Bias current at no load	$I_{\text{Bias}}$	$V_{\text{IN}} = 8\text{ V}$ , $I_{\text{OUT}} = 0\text{ mA}$	—	2.6	5.0	mA
Bias current before the regulation starts	$I_{\text{rush}}$	$V_{\text{IN}} = 6.3\text{ V}$ , $I_{\text{OUT}} = 0\text{ mA}$	—	3	5	mA
Minimum I/O voltage difference 1	$V_{\text{DIF(min)1}}$	$V_{\text{IN}} = 6.3\text{ V}$ , $I_{\text{OUT}} = 500\text{ mA}$ , $T_j = 25^\circ\text{C}$	—	0.4	0.6	V
Minimum I/O voltage difference 2	$V_{\text{DIF(min)2}}$	$V_{\text{IN}} = 6.3\text{ V}$ , $I_{\text{OUT}} = 1\ 200\text{ mA}$ , $T_j = 25^\circ\text{C}$	—	0.5	1.0	V
Peak output current 1 *	$I_{\text{O(Peak)1}}$	$V_{\text{IN}} = 8\text{ V}$ , $T_j = 25^\circ\text{C}$	1.2	1.8	2.4	A
Peak output current 2 * (Excluding the SP type)	$I_{\text{O(Peak)2}}$	$V_{\text{IN}} = 17\text{ V}$ , $T_j = 25^\circ\text{C}$	1.0	1.5	2.0	A
Peak output current 3 * (Excluding the SP type)	$I_{\text{O(Peak)3}}$	$V_{\text{IN}} = 22\text{ V}$ , $T_j = 25^\circ\text{C}$	0.5	1.0	1.5	A
Ripple rejection ratio	RR	$V_{\text{IN}} = 8\text{ V to } 10\text{ V}$ , $I_{\text{OUT}} = 100\text{ mA}$ , $f = 120\text{ Hz}$	47	67	—	dB

Note) \*: This current exceeds  $P_{\text{D(max)}}$  because it is a parameter during abnormal (overcurrent) operation. However, normally, it shall conform to the derating curve ( ■ Characteristic curve chart  $P_{\text{D}} - T_a$  ).

• Design reference data

Note) The characteristics listed below are theoretical values based on the IC design and are not guaranteed.

Parameter	Symbol	Conditions	Min	Typ	Max	Unit
Peak output current 2 * (Only for the SP type)	$I_{\text{O(Peak)2}}$	$V_{\text{IN}} = 17\text{ V}$ , $T_j = 25^\circ\text{C}$	—	1.5	—	A
Peak output current 3 * (Only for the SP type)	$I_{\text{O(Peak)3}}$	$V_{\text{IN}} = 22\text{ V}$ , $T_j = 25^\circ\text{C}$	—	1.0	—	A
Output short-circuit current	$I_{\text{O(Short)}}$	$V_{\text{IN}} = 30\text{ V}$ , $T_j = 25^\circ\text{C}$ The load is shorted.	—	10	—	mA
Thermal protection operating temperature	$T_{\text{j(TH)}}$	$V_{\text{IN}} = 8\text{ V}$	—	150	—	$^\circ\text{C}$
Output voltage temperature coefficient	a	$V_{\text{IN}} = 8\text{ V}$ , $T_j = 25^\circ\text{C to } 125^\circ\text{C}$	—	-40	—	ppm/ $^\circ\text{C}$

Note) \*: This current exceeds  $P_{\text{D(max)}}$  because it is a parameter during abnormal (overcurrent) operation. However, normally, it shall conform to the derating curve ( ■ Characteristic curve chart  $P_{\text{D}} - T_a$  ).

■ Electrical Characteristics at  $T_a = 25^\circ\text{C}$  (continued)

• AN7708/F/SP (8-V type)

Parameter	Symbol	Conditions	Min	Typ	Max	Unit
Output voltage	$V_{\text{OUT}}$	$V_{\text{IN}} = 9\text{ V}$ , $I_{\text{OUT}} = 500\text{ mA}$ , $T_j = 25^\circ\text{C}$	7.76	8.00	8.24	V
Line regulation	$\text{REG}_{\text{IN}}$	$V_{\text{IN}} = 9\text{ V to } 19\text{ V}$ , $I_{\text{OUT}} = 500\text{ mA}$ , $T_j = 25^\circ\text{C}$	—	8	80	mV
Load regulation	$\text{REG}_{\text{LOA}}$	$V_{\text{IN}} = 9\text{ V}$ , $I_{\text{OUT}} = 0\text{ mA to } 1\ 200\text{ mA}$ , $T_j = 25^\circ\text{C}$	—	40	160	mV
Input dependency of bias current	$\Delta I_{\text{Bias(IN)}}$	$V_{\text{IN}} = 9\text{ V to } 19\text{ V}$ , $I_{\text{OUT}} = 500\text{ mA}$ , $T_j = 25^\circ\text{C}$	—	1	10	mA
Load dependency of bias current	$\Delta I_{\text{Bias(LOA)}}$	$V_{\text{IN}} = 9\text{ V}$ , $I_{\text{OUT}} = 0\text{ mA to } 1\ 200\text{ mA}$ , $T_j = 25^\circ\text{C}$	—	10	50	mA
Bias current at no load	$I_{\text{Bias}}$	$V_{\text{IN}} = 9\text{ V}$ , $I_{\text{OUT}} = 0\text{ mA}$	—	2.6	5.0	mA
Bias current before the regulation starts	$I_{\text{rush}}$	$V_{\text{IN}} = 7.2\text{ V}$ , $I_{\text{OUT}} = 0\text{ mA}$	—	3	5	mA
Minimum I/O voltage difference 1	$V_{\text{DIF(min)1}}$	$V_{\text{IN}} = 7.2\text{ V}$ , $I_{\text{OUT}} = 500\text{ mA}$ , $T_j = 25^\circ\text{C}$	—	0.4	0.6	V
Minimum I/O voltage difference 2	$V_{\text{DIF(min)2}}$	$V_{\text{IN}} = 7.2\text{ V}$ , $I_{\text{OUT}} = 1\ 200\text{ mA}$ , $T_j = 25^\circ\text{C}$	—	0.5	1.0	V
Peak output current 1 *	$I_{\text{O(Peak)1}}$	$V_{\text{IN}} = 9\text{ V}$ , $T_j = 25^\circ\text{C}$	1.2	1.8	2.4	A
Peak output current 2 * (Excluding the SP type)	$I_{\text{O(Peak)2}}$	$V_{\text{IN}} = 18\text{ V}$ , $T_j = 25^\circ\text{C}$	1.0	1.5	2.0	A
Peak output current 3 * (Excluding the SP type)	$I_{\text{O(Peak)3}}$	$V_{\text{IN}} = 23\text{ V}$ , $T_j = 25^\circ\text{C}$	0.5	1.0	1.5	A
Ripple rejection ratio	RR	$V_{\text{IN}} = 9\text{ V to } 11\text{ V}$ , $I_{\text{OUT}} = 100\text{ mA}$ , $f = 120\text{ Hz}$	46	66	—	dB

Note) \*: This current exceeds  $P_{\text{D(max)}}$  because it is a parameter during abnormal (overcurrent) operation. However, normally, it shall conform to the derating curve ( ■ Characteristic curve chart  $P_{\text{D}} - T_a$  ).

• Design reference data

Note) The characteristics listed below are theoretical values based on the IC design and are not guaranteed.

Parameter	Symbol	Conditions	Min	Typ	Max	Unit
Peak output current 2 * (Only for the SP type)	$I_{\text{O(Peak)2}}$	$V_{\text{IN}} = 18\text{ V}$ , $T_j = 25^\circ\text{C}$	—	1.5	—	A
Peak output current 3 * (Only for the SP type)	$I_{\text{O(Peak)3}}$	$V_{\text{IN}} = 23\text{ V}$ , $T_j = 25^\circ\text{C}$	—	1.0	—	A
Output short-circuit current	$I_{\text{O(Short)}}$	$V_{\text{IN}} = 30\text{ V}$ , $T_j = 25^\circ\text{C}$ The load is shorted.	—	10	—	mA
Thermal protection operating temperature	$T_{\text{j(TH)}}$	$V_{\text{IN}} = 9\text{ V}$	—	150	—	$^\circ\text{C}$
Output voltage temperature coefficient	a	$V_{\text{IN}} = 9\text{ V}$ , $T_j = 25^\circ\text{C to } 125^\circ\text{C}$	—	-40	—	ppm/ $^\circ\text{C}$

Note) \*: This current exceeds  $P_{\text{D(max)}}$  because it is a parameter during abnormal (overcurrent) operation. However, normally, it shall conform to the derating curve ( ■ Characteristic curve chart  $P_{\text{D}} - T_a$  ).

■ Electrical Characteristics at  $T_a = 25^\circ\text{C}$  (continued)

• AN7709/F/SP (9-V type)

Parameter	Symbol	Conditions	Min	Typ	Max	Unit
Output voltage	$V_{\text{OUT}}$	$V_{\text{IN}} = 10\text{ V}$ , $I_{\text{OUT}} = 500\text{ mA}$ , $T_j = 25^\circ\text{C}$	8.73	9.00	9.27	V
Line regulation	$\text{REG}_{\text{IN}}$	$V_{\text{IN}} = 10\text{ V to } 20\text{ V}$ , $I_{\text{OUT}} = 500\text{ mA}$ , $T_j = 25^\circ\text{C}$	—	9	90	mV
Load regulation	$\text{REG}_{\text{LOA}}$	$V_{\text{IN}} = 10\text{ V}$ , $I_{\text{OUT}} = 0\text{ mA to } 1\ 200\text{ mA}$ , $T_j = 25^\circ\text{C}$	—	45	180	mV
Input dependency of bias current	$\Delta I_{\text{Bias(IN)}}$	$V_{\text{IN}} = 10\text{ V to } 20\text{ V}$ , $I_{\text{OUT}} = 500\text{ mA}$ , $T_j = 25^\circ\text{C}$	—	1	10	mA
Load dependency of bias current	$\Delta I_{\text{Bias(LOA)}}$	$V_{\text{IN}} = 10\text{ V}$ , $I_{\text{OUT}} = 0\text{ mA to } 1\ 200\text{ mA}$ , $T_j = 25^\circ\text{C}$	—	10	50	mA
Bias current at no load	$I_{\text{Bias}}$	$V_{\text{IN}} = 10\text{ V}$ , $I_{\text{OUT}} = 0\text{ mA}$	—	2.6	5.0	mA
Bias current before the regulation starts	$I_{\text{rush}}$	$V_{\text{IN}} = 8.1\text{ V}$ , $I_{\text{OUT}} = 0\text{ mA}$	—	3	5	mA
Minimum I/O voltage difference 1	$V_{\text{DIF(min)1}}$	$V_{\text{IN}} = 8.1\text{ V}$ , $I_{\text{OUT}} = 500\text{ mA}$ , $T_j = 25^\circ\text{C}$	—	0.4	0.6	V
Minimum I/O voltage difference 2	$V_{\text{DIF(min)2}}$	$V_{\text{IN}} = 8.1\text{ V}$ , $I_{\text{OUT}} = 1\ 200\text{ mA}$ , $T_j = 25^\circ\text{C}$	—	0.5	1.0	V
Peak output current 1 *	$I_{\text{O(Peak)1}}$	$V_{\text{IN}} = 10\text{ V}$ , $T_j = 25^\circ\text{C}$	1.2	1.8	2.4	A
Peak output current 2 * (Excluding the SP type)	$I_{\text{O(Peak)2}}$	$V_{\text{IN}} = 19\text{ V}$ , $T_j = 25^\circ\text{C}$	1.0	1.5	2.0	A
Peak output current 3 * (Excluding the SP type)	$I_{\text{O(Peak)3}}$	$V_{\text{IN}} = 24\text{ V}$ , $T_j = 25^\circ\text{C}$	0.5	1.0	1.5	A
Ripple rejection ratio	RR	$V_{\text{IN}} = 10\text{ V to } 12\text{ V}$ , $I_{\text{OUT}} = 100\text{ mA}$ , $f = 120\text{ Hz}$	45	65	—	dB

Note) \*: This current exceeds  $P_{\text{D(max)}}$  because it is a parameter during abnormal (overcurrent) operation. However, normally, it shall conform to the derating curve ( ■ Characteristic curve chart  $P_{\text{D}} - T_a$  ).

• Design reference data

Note) The characteristics listed below are theoretical values based on the IC design and are not guaranteed.

Parameter	Symbol	Conditions	Min	Typ	Max	Unit
Peak output current 2 * (Only for the SP type)	$I_{\text{O(Peak)2}}$	$V_{\text{IN}} = 19\text{ V}$ , $T_j = 25^\circ\text{C}$	—	1.5	—	A
Peak output current 3 * (Only for the SP type)	$I_{\text{O(Peak)3}}$	$V_{\text{IN}} = 24\text{ V}$ , $T_j = 25^\circ\text{C}$	—	1.0	—	A
Output short-circuit current	$I_{\text{O(Short)}}$	$V_{\text{IN}} = 30\text{ V}$ , $T_j = 25^\circ\text{C}$ The load is shorted.	—	10	—	mA
Thermal protection operating temperature	$T_{\text{j(TH)}}$	$V_{\text{IN}} = 10\text{ V}$	—	150	—	$^\circ\text{C}$
Output voltage temperature coefficient	a	$V_{\text{IN}} = 10\text{ V}$ , $T_j = 25^\circ\text{C to } 125^\circ\text{C}$	—	-40	—	ppm/ $^\circ\text{C}$

Note) \*: This current exceeds  $P_{\text{D(max)}}$  because it is a parameter during abnormal (overcurrent) operation. However, normally, it shall conform to the derating curve ( ■ Characteristic curve chart  $P_{\text{D}} - T_a$  ).

■ Electrical Characteristics at  $T_a = 25^\circ\text{C}$  (continued)

• AN7710/F/SP (10-V type)

Parameter	Symbol	Conditions	Min	Typ	Max	Unit
Output voltage	$V_{\text{OUT}}$	$V_{\text{IN}} = 11\text{ V}$ , $I_{\text{OUT}} = 500\text{ mA}$ , $T_j = 25^\circ\text{C}$	9.7	10.0	10.3	V
Line regulation	$\text{REG}_{\text{IN}}$	$V_{\text{IN}} = 11\text{ V}$ to $21\text{ V}$ , $I_{\text{OUT}} = 500\text{ mA}$ , $T_j = 25^\circ\text{C}$	—	10	100	mV
Load regulation	$\text{REG}_{\text{LOA}}$	$V_{\text{IN}} = 11\text{ V}$ , $I_{\text{OUT}} = 0\text{ mA}$ to $1\ 200\text{ mA}$ , $T_j = 25^\circ\text{C}$	—	50	200	mV
Input dependency of bias current	$\Delta I_{\text{Bias(IN)}}$	$V_{\text{IN}} = 11\text{ V}$ to $21\text{ V}$ , $I_{\text{OUT}} = 500\text{ mA}$ , $T_j = 25^\circ\text{C}$	—	1	10	mA
Load dependency of bias current	$\Delta I_{\text{Bias(LOA)}}$	$V_{\text{IN}} = 11\text{ V}$ , $I_{\text{OUT}} = 0\text{ mA}$ to $1\ 200\text{ mA}$ , $T_j = 25^\circ\text{C}$	—	10	50	mA
Bias current at no load	$I_{\text{Bias}}$	$V_{\text{IN}} = 11\text{ V}$ , $I_{\text{OUT}} = 0\text{ mA}$	—	2.6	5.0	mA
Bias current before the regulation starts	$I_{\text{rush}}$	$V_{\text{IN}} = 9\text{ V}$ , $I_{\text{OUT}} = 0\text{ mA}$	—	3	5	mA
Minimum I/O voltage difference 1	$V_{\text{DIF(min)1}}$	$V_{\text{IN}} = 9\text{ V}$ , $I_{\text{OUT}} = 500\text{ mA}$ , $T_j = 25^\circ\text{C}$	—	0.4	0.6	V
Minimum I/O voltage difference 2	$V_{\text{DIF(min)2}}$	$V_{\text{IN}} = 9\text{ V}$ , $I_{\text{OUT}} = 1\ 200\text{ mA}$ , $T_j = 25^\circ\text{C}$	—	0.5	1.0	V
Peak output current 1 *	$I_{\text{O(Peak)1}}$	$V_{\text{IN}} = 11\text{ V}$ , $T_j = 25^\circ\text{C}$	1.2	1.8	2.4	A
Peak output current 2 * (Excluding the SP type)	$I_{\text{O(Peak)2}}$	$V_{\text{IN}} = 20\text{ V}$ , $T_j = 25^\circ\text{C}$	1.0	1.5	2.0	A
Peak output current 3 * (Excluding the SP type)	$I_{\text{O(Peak)3}}$	$V_{\text{IN}} = 25\text{ V}$ , $T_j = 25^\circ\text{C}$	0.5	1.0	1.5	A
Ripple rejection ratio	RR	$V_{\text{IN}} = 11\text{ V}$ to $13\text{ V}$ , $I_{\text{OUT}} = 100\text{ mA}$ , $f = 120\text{ Hz}$	44	64	—	dB

Note) \*: This current exceeds  $P_{\text{D(max)}}$  because it is a parameter during abnormal (overcurrent) operation. However, normally, it shall conform to the derating curve ( ■ Characteristic curve chart  $P_{\text{D}} - T_a$  ).

• Design reference data

Note) The characteristics listed below are theoretical values based on the IC design and are not guaranteed.

Parameter	Symbol	Conditions	Min	Typ	Max	Unit
Peak output current 2 * (Only for the SP type)	$I_{\text{O(Peak)2}}$	$V_{\text{IN}} = 20\text{ V}$ , $T_j = 25^\circ\text{C}$	—	1.5	—	A
Peak output current 3 * (Only for the SP type)	$I_{\text{O(Peak)3}}$	$V_{\text{IN}} = 25\text{ V}$ , $T_j = 25^\circ\text{C}$	—	1.0	—	A
Output short-circuit current	$I_{\text{O(Short)}}$	$V_{\text{IN}} = 30\text{ V}$ , $T_j = 25^\circ\text{C}$ The load is shorted.	—	10	—	mA
Thermal protection operating temperature	$T_{\text{j(TH)}}$	$V_{\text{IN}} = 11\text{ V}$	—	150	—	$^\circ\text{C}$
Output voltage temperature coefficient	a	$V_{\text{IN}} = 11\text{ V}$ , $T_j = 25^\circ\text{C}$ to $125^\circ\text{C}$	—	-40	—	ppm/ $^\circ\text{C}$

Note) \*: This current exceeds  $P_{\text{D(max)}}$  because it is a parameter during abnormal (overcurrent) operation. However, normally, it shall conform to the derating curve ( ■ Characteristic curve chart  $P_{\text{D}} - T_a$  ).

■ Electrical Characteristics at  $T_a = 25^\circ\text{C}$  (continued)

• AN7712/F/SP (12-V type)

Parameter	Symbol	Conditions	Min	Typ	Max	Unit
Output voltage	$V_{\text{OUT}}$	$V_{\text{IN}} = 13\text{ V}$ , $I_{\text{OUT}} = 500\text{ mA}$ , $T_j = 25^\circ\text{C}$	11.64	12.00	12.36	V
Line regulation	$\text{REG}_{\text{IN}}$	$V_{\text{IN}} = 13\text{ V to } 23\text{ V}$ , $I_{\text{OUT}} = 500\text{ mA}$ , $T_j = 25^\circ\text{C}$	—	12	120	mV
Load regulation	$\text{REG}_{\text{LOA}}$	$V_{\text{IN}} = 13\text{ V}$ , $I_{\text{OUT}} = 0\text{ mA to } 1\ 200\text{ mA}$ , $T_j = 25^\circ\text{C}$	—	60	240	mV
Input dependency of bias current	$\Delta I_{\text{Bias(IN)}}$	$V_{\text{IN}} = 13\text{ V to } 23\text{ V}$ , $I_{\text{OUT}} = 500\text{ mA}$ , $T_j = 25^\circ\text{C}$	—	1	10	mA
Load dependency of bias current	$\Delta I_{\text{Bias(LOA)}}$	$V_{\text{IN}} = 13\text{ V}$ , $I_{\text{OUT}} = 0\text{ mA to } 1\ 200\text{ mA}$ , $T_j = 25^\circ\text{C}$	—	10	50	mA
Bias current at no load	$I_{\text{Bias}}$	$V_{\text{IN}} = 13\text{ V}$ , $I_{\text{OUT}} = 0\text{ mA}$	—	2.6	5.0	mA
Bias current before the regulation starts	$I_{\text{rush}}$	$V_{\text{IN}} = 10.8\text{ V}$ , $I_{\text{OUT}} = 0\text{ mA}$	—	3	5	mA
Minimum I/O voltage difference 1	$V_{\text{DIF(min)1}}$	$V_{\text{IN}} = 10.8\text{ V}$ , $I_{\text{OUT}} = 500\text{ mA}$ , $T_j = 25^\circ\text{C}$	—	0.4	0.6	V
Minimum I/O voltage difference 2	$V_{\text{DIF(min)2}}$	$V_{\text{IN}} = 10.8\text{ V}$ , $I_{\text{OUT}} = 1\ 200\text{ mA}$ , $T_j = 25^\circ\text{C}$	—	0.5	1.0	V
Peak output current 1 *	$I_{\text{O(Peak)1}}$	$V_{\text{IN}} = 13\text{ V}$ , $T_j = 25^\circ\text{C}$	1.2	1.8	2.4	A
Peak output current 2 * (Excluding the SP type)	$I_{\text{O(Peak)2}}$	$V_{\text{IN}} = 22\text{ V}$ , $T_j = 25^\circ\text{C}$	1.0	1.5	2.0	A
Peak output current 3 * (Excluding the SP type)	$I_{\text{O(Peak)3}}$	$V_{\text{IN}} = 27\text{ V}$ , $T_j = 25^\circ\text{C}$	0.5	1.0	1.5	A
Ripple rejection ratio	RR	$V_{\text{IN}} = 13\text{ V to } 15\text{ V}$ , $I_{\text{OUT}} = 100\text{ mA}$ , $f = 120\text{ Hz}$	42	62	—	dB

Note) \*: This current exceeds  $P_{\text{D(max)}}$  because it is a parameter during abnormal (overcurrent) operation. However, normally, it shall conform to the derating curve ( ■ Characteristic curve chart  $P_{\text{D}} - T_a$  ).

• Design reference data

Note) The characteristics listed below are theoretical values based on the IC design and are not guaranteed.

Parameter	Symbol	Conditions	Min	Typ	Max	Unit
Peak output current 2 * (Only for the SP type)	$I_{\text{O(Peak)2}}$	$V_{\text{IN}} = 22\text{ V}$ , $T_j = 25^\circ\text{C}$	—	1.5	—	A
Peak output current 3 * (Only for the SP type)	$I_{\text{O(Peak)3}}$	$V_{\text{IN}} = 27\text{ V}$ , $T_j = 25^\circ\text{C}$	—	1.0	—	A
Output short-circuit current	$I_{\text{O(Short)}}$	$V_{\text{IN}} = 30\text{ V}$ , $T_j = 25^\circ\text{C}$ The load is shorted.	—	10	—	mA
Thermal protection operating temperature	$T_{\text{j(TH)}}$	$V_{\text{IN}} = 13\text{ V}$	—	150	—	$^\circ\text{C}$
Output voltage temperature coefficient	a	$V_{\text{IN}} = 13\text{ V}$ , $T_j = 25^\circ\text{C to } 125^\circ\text{C}$	—	-40	—	ppm/ $^\circ\text{C}$

Note) \*: This current exceeds  $P_{\text{D(max)}}$  because it is a parameter during abnormal (overcurrent) operation. However, normally, it shall conform to the derating curve ( ■ Characteristic curve chart  $P_{\text{D}} - T_a$  ).

■ Electrical Characteristics at  $T_a = 25^\circ\text{C}$  (continued)

• AN7715/F/SP (15-V type)

Parameter	Symbol	Conditions	Min	Typ	Max	Unit
Output voltage	$V_{\text{OUT}}$	$V_{\text{IN}} = 16.5 \text{ V}$ , $I_{\text{OUT}} = 500 \text{ mA}$ , $T_j = 25^\circ\text{C}$	14.55	15.00	15.45	V
Line regulation	$\text{REG}_{\text{IN}}$	$V_{\text{IN}} = 16.5 \text{ V}$ to $26.5 \text{ V}$ , $I_{\text{OUT}} = 500 \text{ mA}$ , $T_j = 25^\circ\text{C}$	—	15	150	mV
Load regulation	$\text{REG}_{\text{LOA}}$	$V_{\text{IN}} = 16.5 \text{ V}$ , $I_{\text{OUT}} = 0 \text{ mA}$ to $1\,200 \text{ mA}$ , $T_j = 25^\circ\text{C}$	—	75	300	mV
Input dependency of bias current	$\Delta I_{\text{Bias(IN)}}$	$V_{\text{IN}} = 16.5 \text{ V}$ to $26.5 \text{ V}$ , $I_{\text{OUT}} = 500 \text{ mA}$ , $T_j = 25^\circ\text{C}$	—	1	10	mA
Load dependency of bias current	$\Delta I_{\text{Bias(LOA)}}$	$V_{\text{IN}} = 16.5 \text{ V}$ , $I_{\text{OUT}} = 0 \text{ mA}$ to $1\,200 \text{ mA}$ , $T_j = 25^\circ\text{C}$	—	10	50	mA
Bias current at no load	$I_{\text{Bias}}$	$V_{\text{IN}} = 16.5 \text{ V}$ , $I_{\text{OUT}} = 0 \text{ mA}$	—	2.6	5	mA
Bias current before the regulation starts	$I_{\text{rush}}$	$V_{\text{IN}} = 13.5 \text{ V}$ , $I_{\text{OUT}} = 0 \text{ mA}$	—	3	5	mA
Minimum I/O voltage difference 1	$V_{\text{DIF(min)1}}$	$V_{\text{IN}} = 13.5 \text{ V}$ , $I_{\text{OUT}} = 500 \text{ mA}$ , $T_j = 25^\circ\text{C}$	—	0.4	0.6	V
Minimum I/O voltage difference 2	$V_{\text{DIF(min)2}}$	$V_{\text{IN}} = 13.5 \text{ V}$ , $I_{\text{OUT}} = 1\,200 \text{ mA}$ , $T_j = 25^\circ\text{C}$	—	0.5	1.0	V
Peak output current 1 *	$I_{\text{O(Peak)1}}$	$V_{\text{IN}} = 16.5 \text{ V}$ , $T_j = 25^\circ\text{C}$	1.2	1.8	2.4	A
Peak output current 2 * (Excluding the SP type)	$I_{\text{O(Peak)2}}$	$V_{\text{IN}} = 25 \text{ V}$ , $T_j = 25^\circ\text{C}$	1.0	1.5	2.0	A
Ripple rejection ratio	RR	$V_{\text{IN}} = 16.5 \text{ V}$ to $18.5 \text{ V}$ , $I_{\text{OUT}} = 100 \text{ mA}$ , $f = 120 \text{ Hz}$	40	60	—	dB

Note) \*: This current exceeds  $P_{\text{D(max)}}$  because it is a parameter during abnormal (overcurrent) operation. However, normally, it shall conform to the derating curve ( ■ Characteristic curve chart  $P_{\text{D}} - T_a$  ).

• Design reference data

Note) The characteristics listed below are theoretical values based on the IC design and are not guaranteed.

Parameter	Symbol	Conditions	Min	Typ	Max	Unit
Peak output current 2 * (Only for the SP type)	$I_{\text{O(Peak)2}}$	$V_{\text{IN}} = 25 \text{ V}$ , $T_j = 25^\circ\text{C}$	—	1.5	—	A
Output short-circuit current	$I_{\text{O(Short)}}$	$V_{\text{IN}} = 30 \text{ V}$ , $T_j = 25^\circ\text{C}$ The load is shorted.	—	10	—	mA
Thermal protection operating temperature	$T_{\text{j(TH)}}$	$V_{\text{IN}} = 16.5 \text{ V}$	—	150	—	$^\circ\text{C}$
Output voltage temperature coefficient	a	$V_{\text{IN}} = 16.5 \text{ V}$ , $T_j = 25^\circ\text{C}$ to $125^\circ\text{C}$	—	-40	—	ppm/ $^\circ\text{C}$

Note) \*: This current exceeds  $P_{\text{D(max)}}$  because it is a parameter during abnormal (overcurrent) operation. However, normally, it shall conform to the derating curve ( ■ Characteristic curve chart  $P_{\text{D}} - T_a$  ).

■ Electrical Characteristics at  $T_a = 25^\circ\text{C}$  (continued)

• AN7718/F (18-V type)

Parameter	Symbol	Conditions	Min	Typ	Max	Unit
Output voltage	$V_{\text{OUT}}$	$V_{\text{IN}} = 19.5\text{ V}$ , $I_{\text{OUT}} = 500\text{ mA}$ , $T_j = 25^\circ\text{C}$	17.46	18.00	18.54	V
Line regulation	$\text{REG}_{\text{IN}}$	$V_{\text{IN}} = 19.5\text{ V to } 29.5\text{ V}$ , $I_{\text{OUT}} = 500\text{ mA}$ , $T_j = 25^\circ\text{C}$	—	18	180	mV
Load regulation	$\text{REG}_{\text{LOA}}$	$V_{\text{IN}} = 19.5\text{ V}$ , $I_{\text{OUT}} = 0\text{ mA to } 1\ 200\text{ mA}$ , $T_j = 25^\circ\text{C}$	—	90	360	mV
Input dependency of bias current	$\Delta I_{\text{Bias(IN)}}$	$V_{\text{IN}} = 19.5\text{ V to } 29.5\text{ V}$ , $I_{\text{OUT}} = 500\text{ mA}$ , $T_j = 25^\circ\text{C}$	—	1	10	mA
Load dependency of bias current	$\Delta I_{\text{Bias(LOA)}}$	$V_{\text{IN}} = 19.5\text{ V}$ , $I_{\text{OUT}} = 0\text{ mA to } 1\ 200\text{ mA}$ , $T_j = 25^\circ\text{C}$	—	10	50	mA
Bias current at no load	$I_{\text{Bias}}$	$V_{\text{IN}} = 19.5\text{ V}$ , $I_{\text{OUT}} = 0\text{ mA}$	—	2.6	5.0	mA
Bias current before the regulation starts	$I_{\text{rush}}$	$V_{\text{IN}} = 16.2\text{ V}$ , $I_{\text{OUT}} = 0\text{ mA}$	—	3	5	mA
Minimum I/O voltage difference 1	$V_{\text{DIF(min)1}}$	$V_{\text{IN}} = 16.2\text{ V}$ , $I_{\text{OUT}} = 500\text{ mA}$ , $T_j = 25^\circ\text{C}$	—	0.4	0.6	V
Minimum I/O voltage difference 2	$V_{\text{DIF(min)2}}$	$V_{\text{IN}} = 16.2\text{ V}$ , $I_{\text{OUT}} = 1\ 200\text{ mA}$ , $T_j = 25^\circ\text{C}$	—	0.5	1.0	V
Peak output current 1 *	$I_{\text{O(Peak)1}}$	$V_{\text{IN}} = 19.5\text{ V}$ , $T_j = 25^\circ\text{C}$	1.2	1.8	2.4	A
Peak output current 2 *	$I_{\text{O(Peak)2}}$	$V_{\text{IN}} = 28\text{ V}$ , $T_j = 25^\circ\text{C}$	1.0	1.5	2.0	A
Ripple rejection ratio	RR	$V_{\text{IN}} = 19.5\text{ V to } 21.5\text{ V}$ , $I_{\text{OUT}} = 100\text{ mA}$ , $f = 120\text{ Hz}$	39	59	—	dB

Note) \*: This current exceeds  $P_{\text{D(max)}}$  because it is a parameter during abnormal (overcurrent) operation. However, normally, it shall conform to the derating curve ( ■ Characteristic curve chart  $P_{\text{D}} - T_a$  ).

• Design reference data

Note) The characteristics listed below are theoretical values based on the IC design and are not guaranteed.

Parameter	Symbol	Conditions	Min	Typ	Max	Unit
Output short-circuit current	$I_{\text{O(Short)}}$	$V_{\text{IN}} = 30\text{ V}$ , $T_j = 25^\circ\text{C}$ The load is shorted.	—	10	—	mA
Thermal protection operating temperature	$T_{\text{j(TH)}}$	$V_{\text{IN}} = 19.5\text{ V}$	—	150	—	$^\circ\text{C}$
Output voltage temperature coefficient	a	$V_{\text{IN}} = 19.5\text{ V}$ , $T_j = 25^\circ\text{C to } 125^\circ\text{C}$	—	-40	—	ppm/ $^\circ\text{C}$

■ Electrical Characteristics at  $T_a = 25^\circ\text{C}$  (continued)

• AN7720/F (20-V type)

Parameter	Symbol	Conditions	Min	Typ	Max	Unit
Output voltage	$V_{\text{OUT}}$	$V_{\text{IN}} = 21.5 \text{ V}$ , $I_{\text{OUT}} = 500 \text{ mA}$ , $T_j = 25^\circ\text{C}$	19.4	20.0	20.6	V
Line regulation	$\text{REG}_{\text{IN}}$	$V_{\text{IN}} = 21.5 \text{ V}$ to $29.5 \text{ V}$ , $I_{\text{OUT}} = 500 \text{ mA}$ , $T_j = 25^\circ\text{C}$	—	16	160	mV
Load regulation	$\text{REG}_{\text{LOA}}$	$V_{\text{IN}} = 21.5 \text{ V}$ , $I_{\text{OUT}} = 0 \text{ mA}$ to $1\,200 \text{ mA}$ , $T_j = 25^\circ\text{C}$	—	100	400	mV
Input dependency of bias current	$\Delta I_{\text{Bias(IN)}}$	$V_{\text{IN}} = 21.5 \text{ V}$ to $29.5 \text{ V}$ , $I_{\text{OUT}} = 500 \text{ mA}$ , $T_j = 25^\circ\text{C}$	—	1	10	mA
Load dependency of bias current	$\Delta I_{\text{Bias(LOA)}}$	$V_{\text{IN}} = 21.5 \text{ V}$ , $I_{\text{OUT}} = 0 \text{ mA}$ to $1\,200 \text{ mA}$ , $T_j = 25^\circ\text{C}$	—	10	50	mA
Bias current at no load	$I_{\text{Bias}}$	$V_{\text{IN}} = 21.5 \text{ V}$ , $I_{\text{OUT}} = 0 \text{ mA}$	—	2.6	5.0	mA
Bias current before the regulation starts	$I_{\text{rush}}$	$V_{\text{IN}} = 18 \text{ V}$ , $I_{\text{OUT}} = 0 \text{ mA}$	—	3	5	mA
Minimum I/O voltage difference 1	$V_{\text{DIF(min)1}}$	$V_{\text{IN}} = 18 \text{ V}$ , $I_{\text{OUT}} = 500 \text{ mA}$ , $T_j = 25^\circ\text{C}$	—	0.4	0.6	V
Minimum I/O voltage difference 2	$V_{\text{DIF(min)2}}$	$V_{\text{IN}} = 18 \text{ V}$ , $I_{\text{OUT}} = 1\,200 \text{ mA}$ , $T_j = 25^\circ\text{C}$	—	0.5	1.0	V
Peak output current *	$I_{\text{O(Peak)}}$	$V_{\text{IN}} = 21.5 \text{ V}$ , $T_j = 25^\circ\text{C}$	1.2	1.8	2.4	A
Ripple rejection ratio	RR	$V_{\text{IN}} = 21.5 \text{ V}$ to $23.5 \text{ V}$ , $I_{\text{OUT}} = 100 \text{ mA}$ , $f = 120 \text{ Hz}$	38	58	—	dB

Note) \*: This current exceeds  $P_{\text{D(max)}}$  because it is a parameter during abnormal (overcurrent) operation. However, normally, it shall conform to the derating curve ( ■ Characteristic curve chart  $P_{\text{D}} - T_a$  ).

• Design reference data

Note) The characteristics listed below are theoretical values based on the IC design and are not guaranteed.

Parameter	Symbol	Conditions	Min	Typ	Max	Unit
Output short-circuit current	$I_{\text{O(Short)}}$	$V_{\text{IN}} = 30 \text{ V}$ , $T_j = 25^\circ\text{C}$ The load is shorted.	—	10	—	mA
Thermal protection operating temperature	$T_{\text{j(TH)}}$	$V_{\text{IN}} = 21.5 \text{ V}$	—	150	—	$^\circ\text{C}$
Output voltage temperature coefficient	a	$V_{\text{IN}} = 21.5 \text{ V}$ , $T_j = 25^\circ\text{C}$ to $125^\circ\text{C}$	—	-40	—	ppm/ $^\circ\text{C}$

■ Electrical Characteristics at  $T_a = 25^\circ\text{C}$  (continued)

• AN7724/F (24-V type)

Parameter	Symbol	Conditions	Min	Typ	Max	Unit
Output voltage	$V_{\text{OUT}}$	$V_{\text{IN}} = 25.5 \text{ V}$ , $I_{\text{OUT}} = 500 \text{ mA}$ , $T_j = 25^\circ\text{C}$	23.28	24.00	24.72	V
Line regulation	$\text{REG}_{\text{IN}}$	$V_{\text{IN}} = 25.5 \text{ V}$ to $29.5 \text{ V}$ , $I_{\text{OUT}} = 500 \text{ mA}$ , $T_j = 25^\circ\text{C}$	—	9.6	96	mV
Load regulation	$\text{REG}_{\text{LOA}}$	$V_{\text{IN}} = 25.5 \text{ V}$ , $I_{\text{OUT}} = 0 \text{ mA}$ to $1\ 200 \text{ mA}$ , $T_j = 25^\circ\text{C}$	—	120	480	mV
Input dependency of bias current	$\Delta I_{\text{Bias(IN)}}$	$V_{\text{IN}} = 25.5 \text{ V}$ to $29.5 \text{ V}$ , $I_{\text{OUT}} = 500 \text{ mA}$ , $T_j = 25^\circ\text{C}$	—	1	10	mA
Load dependency of bias current	$\Delta I_{\text{Bias(LOA)}}$	$V_{\text{IN}} = 25.5 \text{ V}$ , $I_{\text{OUT}} = 0 \text{ mA}$ to $1\ 200 \text{ mA}$ , $T_j = 25^\circ\text{C}$	—	10	50	mA
Bias current at no load	$I_{\text{Bias}}$	$V_{\text{IN}} = 25.5 \text{ V}$ , $I_{\text{OUT}} = 0 \text{ mA}$	—	2.6	5.0	mA
Bias current before the regulation starts	$I_{\text{rush}}$	$V_{\text{IN}} = 21.6 \text{ V}$ , $I_{\text{OUT}} = 0 \text{ mA}$	—	3	5	mA
Minimum I/O voltage difference 1	$V_{\text{DIF(min)1}}$	$V_{\text{IN}} = 21.6 \text{ V}$ , $I_{\text{OUT}} = 500 \text{ mA}$ , $T_j = 25^\circ\text{C}$	—	0.4	0.6	V
Minimum I/O voltage difference 2	$V_{\text{DIF(min)2}}$	$V_{\text{IN}} = 21.6 \text{ V}$ , $I_{\text{OUT}} = 1\ 200 \text{ mA}$ , $T_j = 25^\circ\text{C}$	—	0.5	1.0	V
Peak output current *	$I_{\text{O(Peak)}}$	$V_{\text{IN}} = 25.5 \text{ V}$ , $T_j = 25^\circ\text{C}$	1.2	1.8	2.4	A
Ripple rejection ratio	RR	$V_{\text{IN}} = 25.5 \text{ V}$ to $27.5 \text{ V}$ , $I_{\text{OUT}} = 100 \text{ mA}$ , $f = 120 \text{ Hz}$	36	56	—	dB

Note) \*: This current exceeds  $P_{\text{D(max)}}$  because it is a parameter during abnormal (overcurrent) operation. However, normally, it shall conform to the derating curve ( ■ Characteristic curve chart  $P_{\text{D}} - T_a$  ).

• Design reference data

Note) The characteristics listed below are theoretical values based on the IC design and are not guaranteed.

Parameter	Symbol	Conditions	Min	Typ	Max	Unit
Output short-circuit current	$I_{\text{O(Short)}}$	$V_{\text{IN}} = 30 \text{ V}$ , $T_j = 25^\circ\text{C}$ The load is shorted.	—	10	—	mA
Thermal protection operating temperature	$T_{\text{j(TH)}}$	$V_{\text{IN}} = 25.5 \text{ V}$	—	150	—	$^\circ\text{C}$
Output voltage temperature coefficient	a	$V_{\text{IN}} = 25.5 \text{ V}$ , $T_j = 25^\circ\text{C}$ to $125^\circ\text{C}$	—	-40	—	ppm/ $^\circ\text{C}$

■ Usage Notes

1. Input short-circuit protection circuit

When the DC input pin (pin1) and the ground pin (pin2) of our conventional three-pin regulators (AN7800 series, etc.) were short-circuited at normal use conditions in some cases, the voltage of the output pin (pin3) becomes higher than that of the DC input pin and electrons charged in the output capacitor  $C_{OUT}$  flow into the input side, resulting in break of the element.

In those cases, it was necessary for you to connect a general silicon diode as shown in the figure on the right. In the AN7700/AN7700F/AN7700SP series, however, it is not necessary to connect the protection diode because these series have a built-in protection circuit to safeguard the element from discharge current.

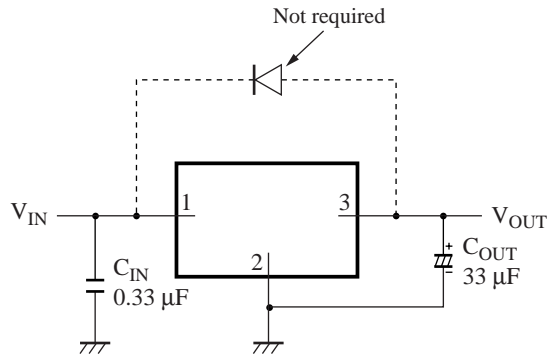

2. Capacitor for external compensation

To maintain the stability, insert a 33-mF capacitor as close to pin 3 and pin 2 as possible. In case of using at low temperature, decrease in capacity of the aluminum electrolytic capacitor and increase of ESR of this capacitor may lead to oscillation.

In the AN7700/AN7700F/AN7700SP series, for the output capacitor  $C_{OUT}$ , it is recommended to use an aluminum electrolytic capacitor or tantalum capacitor whose equivalent series resistance (ESR) has the temperature characteristic within the recommended area shown on the right.

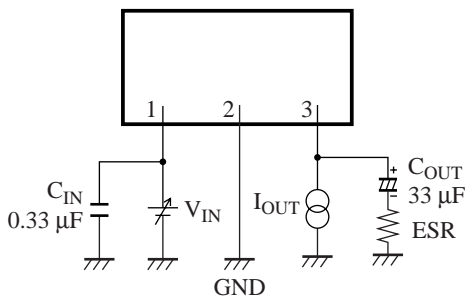

Output capacitor ESR  
(Equivalent series resistance)  $T_a = 25^\circ\text{C}$

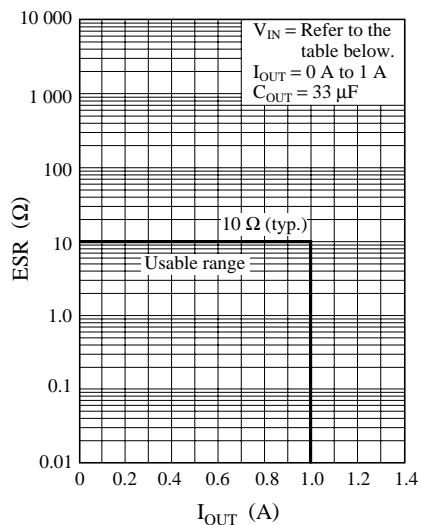

3. Others

Cautions for the input voltage that exceeds the operating supply voltage:

- 1) The overvoltage protection is activated with the ASO protection circuit when  $V_{IN} = 30\text{ V}$  is applied, and the output shuts down occasionally. (3-V type to 10-V type)
- 2) Please note that at  $I_{OUT} < 2\text{ mA}$ , the output voltage rises and may exceed the maximum of the operation range. (12-V type to 24-V type)

Part No.	$V_{IN}$
AN7703/F	4 V to 14 V
AN77033SP	4.3 V to 14 V
AN77035SP	4.5 V to 14 V
AN7704/F	5 V to 15 V
AN7705/F/SP	6 V to 16 V
AN7706/F/SP	7 V to 17 V
AN7707/F/SP	8 V to 18 V
AN7708/F/SP	9 V to 19 V
AN7709/F/SP	10 V to 20 V
AN7710/F/SP	11 V to 21 V
AN7712/F/SP	13 V to 23 V
AN7715/F/SP	16.5 V to 26.5 V
AN7718/F	19.5 V to 29.5 V
AN7720/F	21.5 V to 29.5 V
AN7724/F	25.5 V to 29.5 V

■ Characteristic Curve Chart

$P_D - T_a$  (AN7700 series)

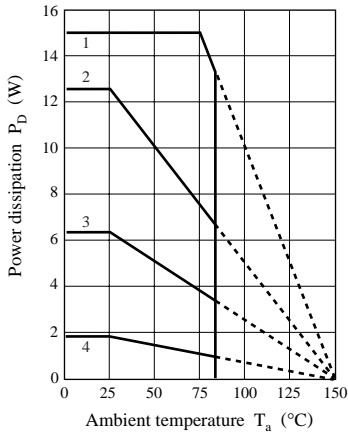

Installation conditions to heat sink  
Tightening torque 6 kg·cm  
Heat radiation compound used  
Thermal resistance value:  
 $R_{th(j-c)} = 5^\circ\text{C/W}$   
 $R_{th(j-a)} = 65^\circ\text{C/W}$

- 1) Infinite heat sink: 15000 mW
- 2) 5°C/W heat sink: 12500 mW
- 3) 15°C/W heat sink: 6300 mW
- 4) Without heat sink: 1923 mW

$P_D - T_a$  (AN7700F series)

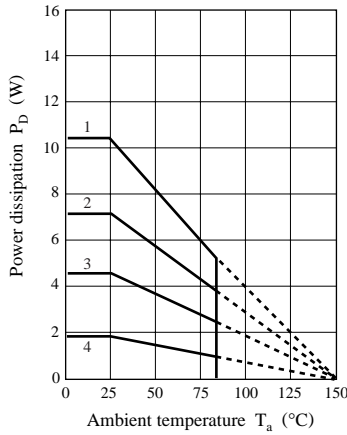

Installation conditions to heat sink  
Tightening torque 6 kg·cm  
Heat radiation compound used  
Thermal resistance value:  
 $R_{th(j-c)} = 12.2^\circ\text{C/W}$   
 $R_{th(j-a)} = 65^\circ\text{C/W}$

- 1) Infinite heat sink: 10250 mW
- 2) 5°C/W heat sink: 7300 mW
- 3) 15°C/W heat sink: 4500 mW
- 4) Without heat sink: 1923 mW

$P_D - T_a$  (AN7700SP series)

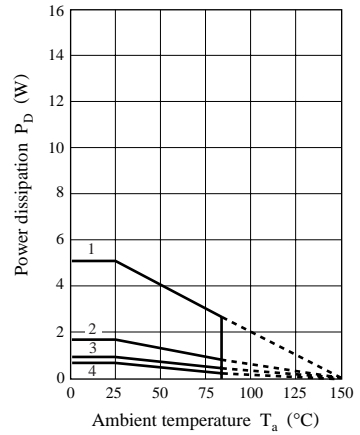

- 1) When AL board is mounted (Basic size : 50 × 50 × t2.0 mm<sup>3</sup>)  
 $R_{th(j-a)} = 25.0^\circ\text{C/W}$
- 2) When glass epoxy is mounted 2 (Basic size : 50 × 50 × t1.5 mm<sup>3</sup>)  
 $R_{th(j-a)} = 89.3^\circ\text{C/W}$
- 3) When glass epoxy is mounted 1 (Basic size : 50 × 50 × t1.7 mm<sup>3</sup>)  
 $R_{th(j-a)} = 147.0^\circ\text{C/W}$
- 4) Without heat sink  
 $R_{th(j-a)} = 178.0^\circ\text{C/W}$

$V_{OUT} - V_{IN}$

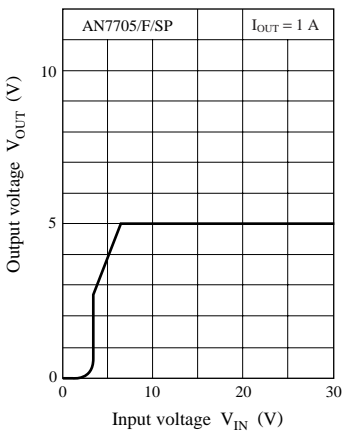

$I_{Bias} - V_{IN}$

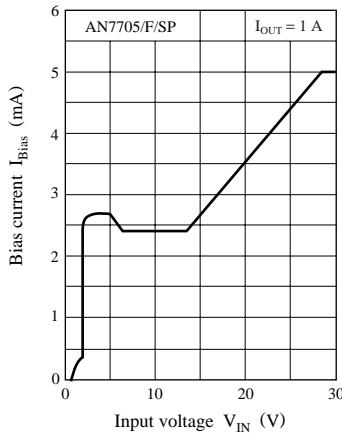

$V_{OUT} - I_{OUT}$

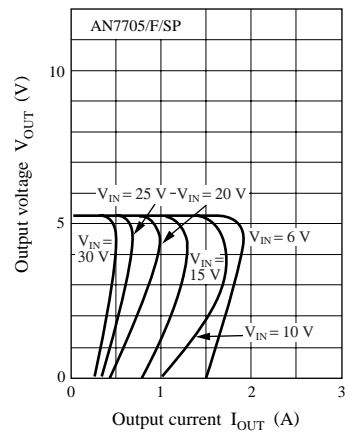

■ Characteristic Curve Chart (continued)

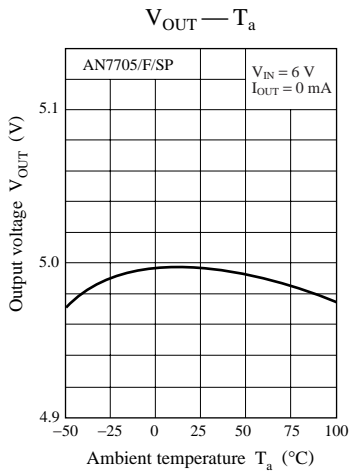
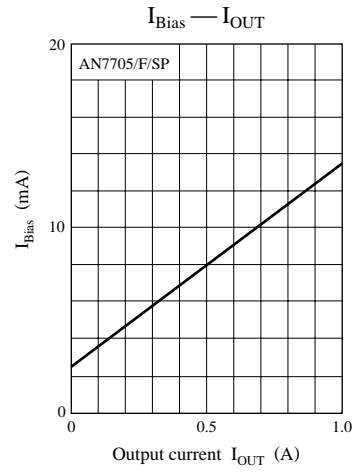
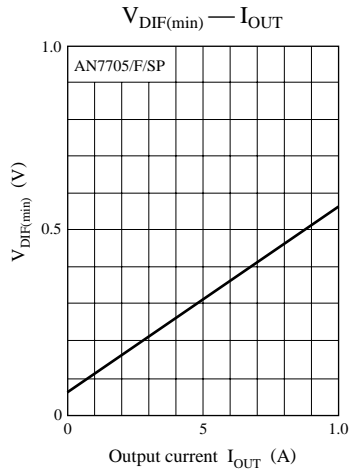
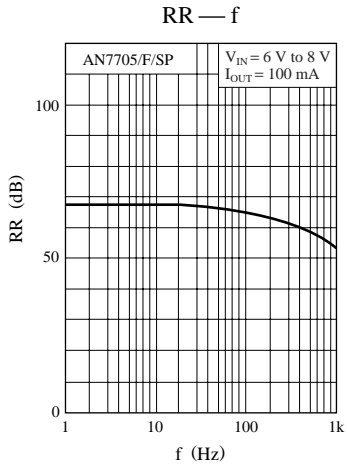



LittleDiode supplies new, hard to find or obsolete electronic components and semiconductors all over the world.

With over two million different components listed you are sure to find the part you need.

Feel free to visit us today at our online store:

[LittleDiode.com](http://LittleDiode.com)

Looking forward to providing you with the best possible service.