

AN7535NSA

Headphone amplifier IC for portable equipment

Overview

The AN7535NSA is an audio signal processing IC in which line amplifiers and beep circuit are built in the headphone amplifiers for use in portable equipment. Its headphone output block is using the center amplifier method which eliminates the need for coupling capacitor so that the circuit is most suitable for rationalization of audio circuit.

Features

- Output coupling capacitor is not required (Center amplifier method)
- Built-in line amplifiers
- Built-in headphone amplifier gain change-over circuit (8 dB/12 dB)
- Built-in mute circuit
- Built-in beep circuit
- Built-in circuit against a shock noise generated when power supply is momentary cut off.

Applications

- Potable CD and MD players, etc.

Block Diagram

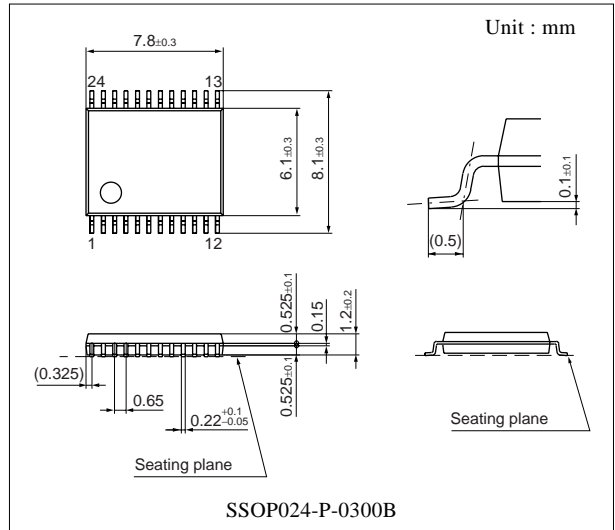
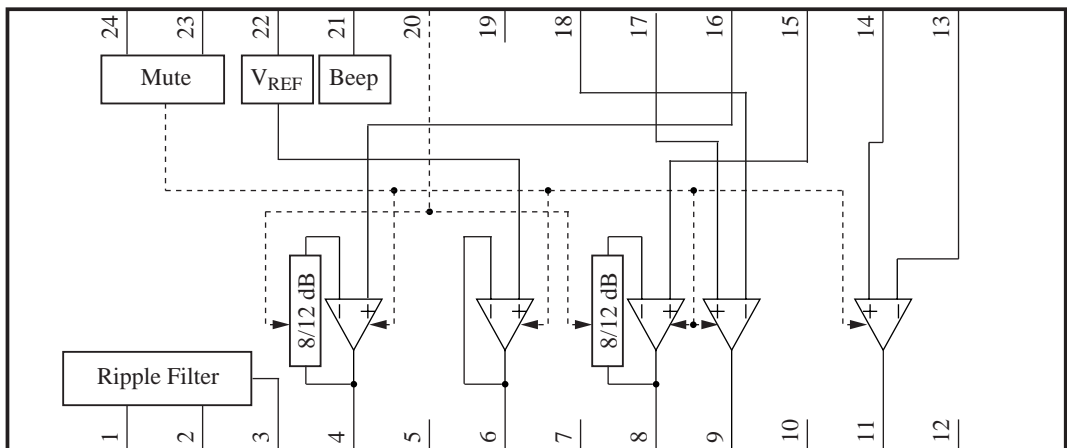

■ Pin Descriptions

Pin No.	Description	Pin No.	Description
1	V _{CC1}	13	Line amplifier ch.2 NF pin
2	Ripple filter	14	Line amplifier ch.2 input pin
3	Supply voltage	15	Headphone amplifier ch.2 input pin
4	Headphone amplifier ch.1 output pin	16	Headphone amplifier ch.1 input pin
5	N.C.	17	Line amplifier ch.1 input pin
6	Center amplifier output pin	18	Line amplifier ch.1 NF pin
7	Output GND	19	Input GND
8	Headphone amplifier ch.2 output pin	20	Headphone amplifier gain change-over pin
9	Line amplifier ch.1 output pin	21	Beep input pin
10	Line amplifier supply voltage	22	Internal reference voltage
11	Line amplifier ch.2 output pin	23	Mute pin
12	N.C.	24	Mute time-constant

■ Absolute maximum ratings

Parameter	Symbol	Rating	Unit
Supply voltage* ²	V _{CC}	7	V
Line amplifier supply voltage* ²	V _{CC-LINE}	7	V
Supply current	I _{CC}	200.0	mA
Line amplifier supply current	I _{CC-LINE}	20.0	mA
Power dissipation* ³	P _D	370	mW
Operating ambient temperature* ¹	T _{opr}	-20 to + 75	°C
Storage temperature* ¹	T _{stg}	-55 to + 150	°C

Notes) *1 : All items are at T_a = 25°C, except for the operating ambient temperature and storage temperature parameters .

*2 : Without signal

*3 : T_a = 75°C when mounted on the recommended printed circuit board (Glass epoxy board 50 mm × 50 mm × t0.8 mm)

*4 : Use under the condition of V_{CC-LINE} ≥ V_{CC}

■ Recommended Operating Range

Parameter	Symbol	Range	Unit
Supply voltage* ¹	V _{CC}	1.8 to 3.4	V
	V _{CC-LINE}	1.8 to 3.4 (V _{CC} to V _{CC} + 0.2)	V

■ Electrical Characteristics

Unless otherwise specially specified, $V_{CC} = 2.6 \text{ V}$, $V_{CC-LINE} = 2.8 \text{ V}$, $f = 1 \text{ kHz}$, $R_L = 16 \Omega$ (HP out), $R_L = 10 \text{ k}\Omega$ (line out), $T_a = 25^\circ\text{C}$

Parameter	Symbol	Conditions	Min	Typ	Max	Unit
Quiescent current 1	I_{CQM}	Mute-on	0.7	1.9	3.0	mA
Quiescent current 2	I_{CQ1}	Without input, pin 3 current, Mute-off	2.2	4.3	8.8	mA
Quiescent current 3	I_{CQ2}	Without input, pin 10 current, Mute-off	0.4	1.1	2.0	mA
HP amplifier						
Voltage gain 1	G_{V1}	$V_O = 0.35 \text{ V[rms]}$, $G_V = 12 \text{ dB}$	10.0	11.7	13.0	dB
Voltage gain 2	G_{V2}	$V_O = 0.35 \text{ V[rms]}$, $G_V = 8 \text{ dB}$	6.0	7.8	9.0	dB
Channel balance	CB	$V_O = 0.35 \text{ V[rms]}$, $G_V = 8 \text{ dB}$	-1	0	1	dB
Total harmonic distortion	THD	$V_O = 0.35 \text{ V[rms]}$, $G_V = 8 \text{ dB}$	—	0.05	0.2	%
Maximum output power	P_O	THD = 10%, $G_V = 8 \text{ dB}$	20	44	—	mW
Output noise voltage* ¹	V_{NO}	$R_g = 10 \text{ k}\Omega$, $G_V = 8 \text{ dB}$	—	-102	-93	dBm
Channel cross-talk* ²	CT	$V_O = 0.35 \text{ V[rms]}$, $G_V = 8 \text{ dB}$	40	45	—	dB
Ripple rejection	RR	$V_R = 0.1 \text{ V[rms]}$, $f_R = 100 \text{ Hz}$, $G_V = 8 \text{ dB}$	60	77	—	dB
Mute attenuation* ²	V_{MUTE}	$V_{IN} = -15 \text{ dBm}$, $G_V = 8 \text{ dB}$	70	98	—	dB
Beep sound output voltage* ³	V_{BEEP}	$V_{IN} = 2.2 \text{ dBm}$, $G_V = 8 \text{ dB}$	5	10	15	mV[p-p]
Line amplifier						
Voltage gain	G_{VL}	$V_{IN} = -6 \text{ dBm}$	5.0	6.0	7.0	dB
Total harmonic distortion	THD_L	$V_{IN} = -6 \text{ dBm}$	—	0.003	0.02	%
Channel cross-talk	CTL	$V_{IN} = -6 \text{ dBm}$	85	95	—	dB
Output noise voltage* ¹	V_{NOL}	$R_g = 10 \text{ k}\Omega$	—	-104	-98	dBm
Mute attenuation* ²	V_{MUTEL}	$V_{IN} = -15 \text{ dBm}$	70	80	—	dB
Mute operating voltage	V_{MON}	Pin 23 voltage for mute operation	—	—	0.5	V
Mute release voltage	V_{MOFF}	Pin 23 voltage for mute release	2.2	—	—	V
Gain change-over operating voltage	V_{GCON}	Pin 20 voltage for voltage gain 10.9 dB to 13.9 dB	—	—	0.5	V
Gain change-over Off voltage	V_{GCOFF}	Pin 20 voltage for voltage gain 6.9 dB to 9.9 dB	2.2	—	—	V

Note) *1 : Using A curve filter

*2 : Using 30 kHz LPF

*3 : The specifications are guaranteed under the both mute on/off conditions.

■ Electrical Characteristics (continued)

Unless otherwise specially specified, $V_{CC} = 2.6 \text{ V}$, $V_{CC-LINE} = 2.8 \text{ V}$, $f = 1 \text{ kHz}$, $R_L = 16 \Omega$ (HP out), $R_L = 10 \text{ k}\Omega$ (line out), $T_a = 25^\circ\text{C}$

• Design reference data

Note) The following characteristics are the reference values for design and not guaranteed values.

Parameter	Symbol	Conditions	Min	Typ	Max	Unit
Quiescent current 1	I_{CQM}	Mute-on	—	1.9	—	mA
Quiescent current 2	I_{CQ1}	Without input, pin 3 current, Mute-off	—	4.6	—	mA
Quiescent current 3	I_{CQ2}	Without input, pin10 current, Mute-off	—	1.1	—	mA
HP amplifier						
Voltage gain 1	G_{V1}	$V_O = 0.35 \text{ V[rms]}$, $G_V = 12 \text{ dB}$	—	11.7	—	dB
Voltage gain 2	G_{V2}	$V_O = 0.35 \text{ V[rms]}$, $G_V = 8 \text{ dB}$	—	7.8	—	dB
Channel balance	CB	$V_O = 0.35 \text{ V[rms]}$, $G_V = 8 \text{ dB}$	—	0	—	dB
Total harmonic distortion	THD	$V_O = 0.35 \text{ V[rms]}$, $G_V = 8 \text{ dB}$	—	0.05	—	%
Maximum output power	P_O	THD = 10%, $G_V = 8 \text{ dB}$	—	52	—	mW
Output noise voltage* ¹	V_{NO}	$R_g = 10 \text{ k}\Omega$, $G_V = 8 \text{ dB}$	—	-102	—	dBm
Channel cross-talk* ²	CT	$V_O = 0.35 \text{ V[rms]}$, $G_V = 8 \text{ dB}$	—	45	—	dB
Ripple rejection	RR	$V_R = 0.1 \text{ V[rms]}$, $f_R = 100 \text{ Hz}$, $G_V = 8 \text{ dB}$	—	77	—	dB
Mute attenuation* ²	V_{MUTE}	$V_{IN} = -15 \text{ dBm}$, $G_V = 8 \text{ dB}$	—	98	—	dB
Beep sound output voltage* ³	V_{BEEP}	$V_{IN} = 2.2 \text{ dBm}$, $G_V = 8 \text{ dB}$	—	10	—	mV[p-p]
Line amplifier						
Voltage gain	G_{VL}	$V_{IN} = -6 \text{ dBm}$	—	6.0	—	dB
Total harmonic distortion	THD_L	$V_{IN} = -6 \text{ dBm}$	—	0.003	—	%
Channel cross-talk	CTL	$V_{IN} = -6 \text{ dBm}$	—	95	—	dB
Output noise voltage* ¹	V_{NOL}	$R_g = 10 \text{ k}\Omega$	—	-104	—	dBm
Mute attenuation* ²	V_{MUTEL}	$V_{IN} = -15 \text{ dBm}$	—	80	—	dB

Notes) *1 : Using A curve filter

*2 : Using 30 kHz LPF

*3 : Under the both mute on and off conditions

■ Terminal Equivalent Circuits

Pin No.	Equivalent circuit	Description	DC (V)
1		V_{CC1} Internally stabilized power supply	2.4
2		Ripple filter Internally stabilized power supply	2.17
3	—	V_{CC} Headphone amplifier side supply voltage	2.6
4		Headphone amplifier ch.1 output pin	1.1
5	—	N.C.	—
6		Headphone amplifier center output pin	1.1
7	—	Output GND	0
8		Headphone amplifier ch.2 output pin	1.1

■ Terminal Equivalent Circuits (continued)

Pin No.	Equivalent circuit	Description	DC(V)
9		Line amplifier ch.1 output pin	1.4
10	—	Line amplifier supply voltage	2.8
11		Line amplifier ch.1 output pin	1.4
12	—	N.C.	—
13		Line amplifier ch.2 NF pin $R_{IN} = 100\text{ k}\Omega$	1.4
14		Line amplifier ch.2 input pin $R_{IN} = 100\text{ k}\Omega$	1.4
15		Headphone amplifier ch.2 input pin $R_{IN} = 14.4\text{ k}\Omega$	1.1
16		Headphone amplifier ch.1 input pin $R_{IN} = 14.4\text{ k}\Omega$	1.1

■ Terminal Equivalent Circuits (continued)

Pin No.	Equivalent circuit	Description	DC(V)
17		Line amplifier ch.1 input pin $R_{IN} = 100\text{ k}\Omega$	1.4
18		Line amplifier ch.1 NF pin $R_{IN} = 100\text{ k}\Omega$	1.4
19	—	Input GND	0
20		Headphone amplifier gain change-over pin $G_V = 8\text{ dB mode}$ $V_{20} > V_1 - 0.2\text{ V}$ $G_V = 12\text{ dB mode}$ $V_{20} < 0.5\text{ V}$ $R_{IN} = 100\text{ k}\Omega$	—
21		Beep input pin $R_{IN} = 100\text{ k}\Omega$ Beep circuit operation when $V_{21} < V_{CC} - V_{BE}$ Gain is fixed by internal circuit	—
22		Internal reference voltage $R_{IN} = 100\text{ k}\Omega$ Beep circuit operation when $V_{21} < V_{CC} - V_{BE}$ Gain is fixed by internal circuit	1.2
23		Mute pin Mute-on $V_{23} > V_1 - 0.2\text{ V}$ Mute-off $V_{23} < 0.5\text{ V}$ $R_{IN} = 100\text{ k}\Omega$	—
24		Mute time constant Mute-on/off threshold value Mute-on $V_{24} < V_{REFC} = 1.2\text{ V}$ Mute-off $V_{24} > V_{REFC} = 1.2\text{ V}$	When Mute-on 0 When Mute-off 2.0

■ Usage Notes

1. Use N.C. pin in open or grounded condition.
2. The output middle point of line amplifier is determined by the following equation ;
Depending on the values of V_{CC} and $V_{CC-LINE}$, the middle point of line amplifier may shift from $1/2V_{CC-LINE}$.
Use it by conducting a fine adjustment of R_1 and R_2 .

$$V_{O-DC} = V_{CC} \frac{25}{30} \cdot 1.1 \cdot \frac{R_1}{R_1 + R_2}$$

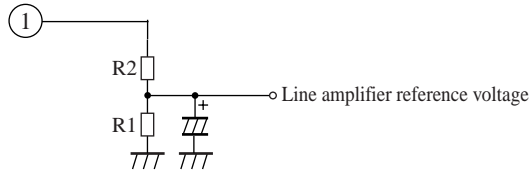

3. It is recommended that the V_{CC} (pin 3) should be used at the same potential of the $V_{CC-LINE}$ (pin 10), or 0.2 V lower than the potential of $V_{CC-LINE}$ (pin 10).

■ Technical Information

- $P_D - T_a$ curves of SSOP024-P-0300B

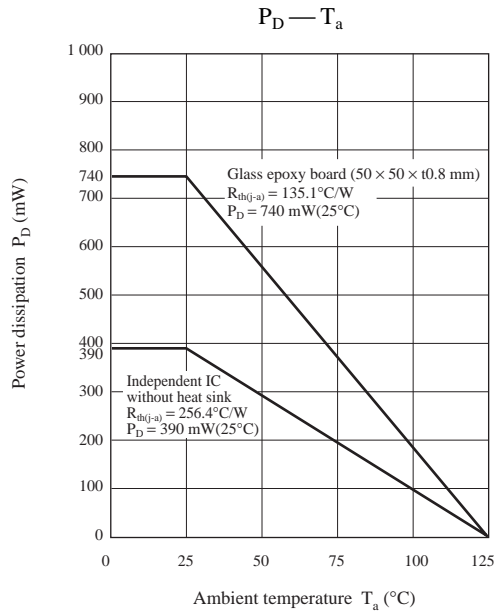



LittleDiode supplies new, hard to find or obsolete electronic components and semiconductors all over the world.

With over two million different components listed you are sure to find the part you need.

Feel free to visit us today at our online store:

LittleDiode.com

Looking forward to providing you with the best possible service.