

BTL Audio Power IC AN7510/7520 Series

■ Overview

The AN7510/7520 series is a 0.5W to 3W BTL audio power amplifier IC. Equipped with a standby function and mute or DC volume circuit, the series includes a lineup of single and dual output models. With simplified set design due to minimum external components, this IC has a wide variety of applications.

■ Features

- Operating power source voltage: 3.0V to 13.5V.
- Built-in standby function.
- Built-in mute or DC volume circuit.

■ Specifications

Parameters Product name	Output power	Vcc	Load resistance	Standby	Mute	Volume	Package
AN7510S	0.5W×2ch	5V	16Ω	○	○		SOP-16pin
AN7511S	0.5W×1ch	5V	16Ω	○	○		SOP-8pin
AN7512S	0.5W×2ch	5V	16Ω	○		○	SOP-16pin
AN7513S	0.5W×1ch	5V	16Ω	○		○	SOP-8pin
AN7510	1.0W×2ch	5V	8Ω	○	○		HDIP-16pin
AN7511	1.0W×1ch	5V	8Ω	○	○		DIP-8pin
AN7512	1.0W×2ch	5V	8Ω	○		○	HDIP-16pin
AN7513	1.0W×1ch	5V	8Ω	○		○	DIP-8pin
* AN7520	3.0W×2ch	8V	8Ω	○	○		HSIP-12pin
* AN7521	3.0W×1ch	8V	8Ω	○	○		HSIP-9pin
AN7522	3.0W×2ch	8V	8Ω	○		○	HSIP-12pin
AN7523	3.0W×1ch	8V	8Ω	○		○	HSIP-9pin

* : Planned

■ Applications

- TVs ● Audio equipment ● Personal computers ● Active speakers

† The products and specifications are subject to change without any notice. Please ask for the latest product standards to guarantee the satisfaction of your product requirements.

AN7510, AN7510S

Dual 0.5,1W BTL Audio Power Amplifier Circuit

■ Features

- AN7510: $V_{cc}=5V, Output=1W(8\Omega)$
- AN7510S: $V_{cc}=5V, Output=0.5W(16\Omega)$
- Built-in Standby function.
- Built-in Mute circuits.

■ Applications

- TVs, Audio equipment, Personal computers, Active speakers

■ Block Diagram

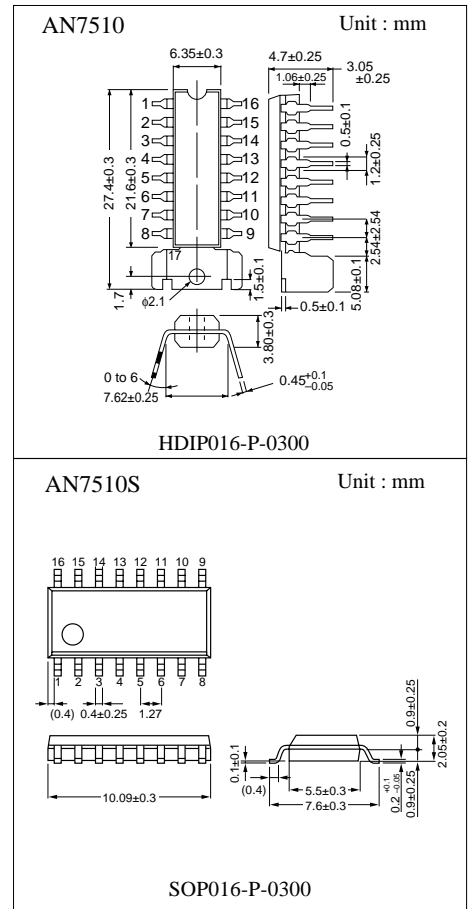
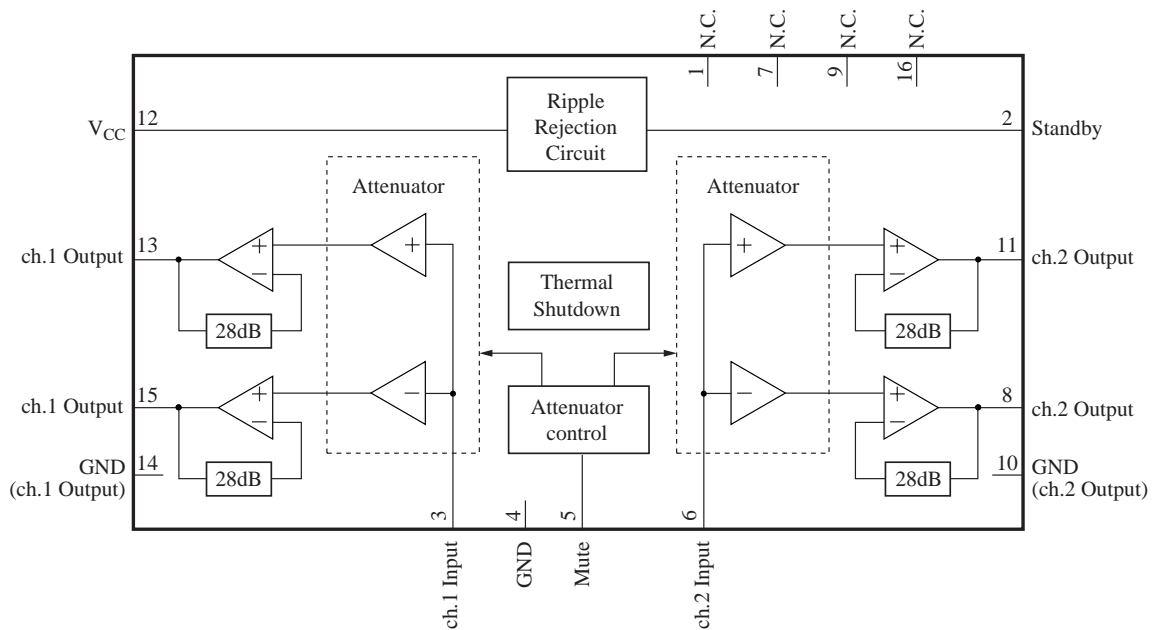

■ Pin Descriptions

Pin No.	Function	Pin No.	Function
1	N.C	9	N.C
2	Standby	10	GND(Output ch2)
3	ch1 Input	11	ch2 Output(+)
4	GND(Input)	12	Vcc
5	Mute	13	ch1 Output(+)
6	ch2 Input	14	GND(Output ch1)
7	N.C	15	ch1 Output(-)
8	ch2 Output(-)	16	N.C

■ Absolute Maximum Ratings

Parameter	Symbol	Ratio	Unit	Note
Storage temperature	T _{stg}	AN7510 -55 to +150	°C	1
		AN7510S -55 to +125		
Operating ambient temperature	T _{opr}	-25 to +70	°C	1
Supply voltage	V _{cc}	14	V	2
Supply current	I _{cc}	2.0	A	
Power dissipation	PD	AN7510 1127	mW	Ta=70°C
		AN7510S 236		

Note1) Ta=25°C except storage temperature and operating ambient temperature.

Note2) At no-signal.

■ Operating Supply Voltage Range

Operating supply voltage range	V _{cc}	3.5V to 13.5V
--------------------------------	-----------------	---------------

■ Electrical Characteristics ($V_{CC}=5.0V, R_L=8\Omega, \text{freq}=1\text{kHz}, T_a=25^\circ\text{C} \pm 2^\circ\text{C}$)

Parameter	Symbol	Condition	min.	typ.	max.	Unit	Note
Quiescent current	ICQ	$V_{IN}=0\text{mV}$	–	50	100	mA	
Standby current	ISTB	$V_{IN}=0\text{mV}$	–	1	10	μA	
Output noise voltage	VNO	$R_g=10\text{k}\Omega$	–	0.14	0.4	mVrms	1
Voltage gain	Gv	$P_o=0.25\text{W}$	32	34	36	dB	
Total harmonic distortion	THD	$P_o=0.25\text{W}$	–	0.05	0.5	%	
Maximum power output	Po	THD=10%	0.8	1.1	–	W	
Ripple rejection ratio	RR	$R_g=10\text{k}\Omega$ $V_r=1\text{Vrms}, f_r=120\text{Hz}$	30	50	–	dB	1
Output offset voltage	Voff	$R_g=10\text{k}\Omega$	-300	0	300	mV	
Muting effect	MT	$P_o=0.25\text{W}$	70	86	–	dB	1
Channel balance	CB	$P_o=0.25\text{W}$	-1	0	1	dB	
Channel crosstalk	CT	$P_o=0.25\text{W}$	55	65	–	dB	

Note1) For this measurement, use the filter <Bandwidth:15Hz to 30kHz(12dB/octave)>

■ Application Circuit

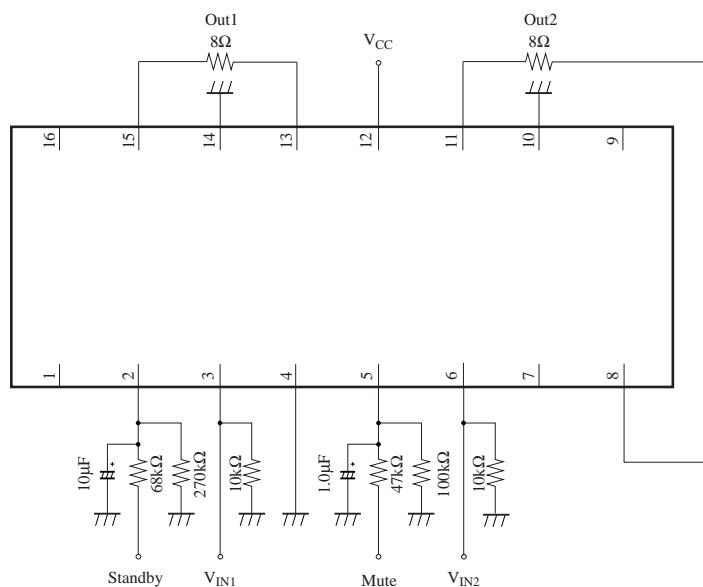

■ Characteristic Curve(AN7510)

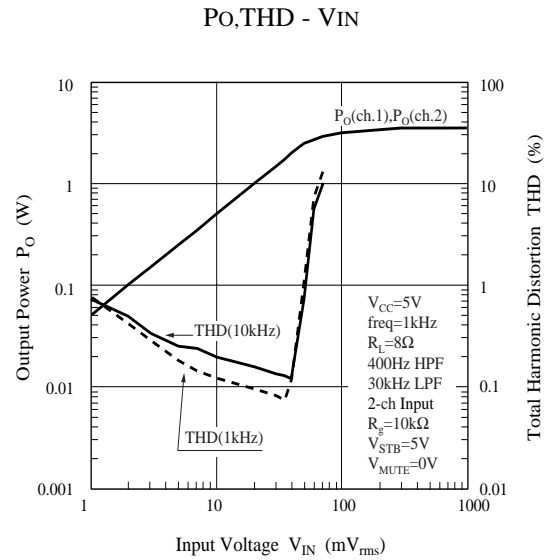
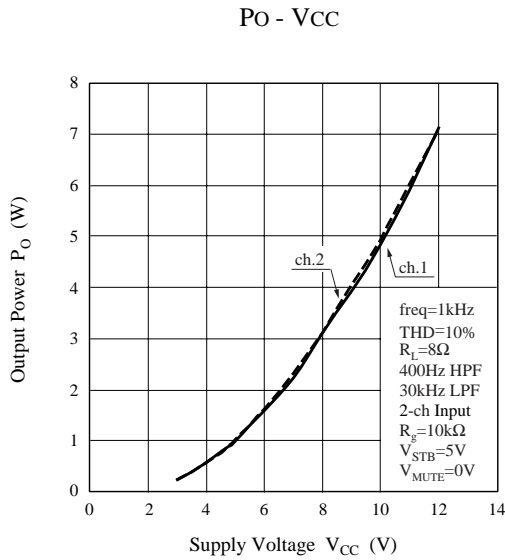

■ Package Power Dissipation

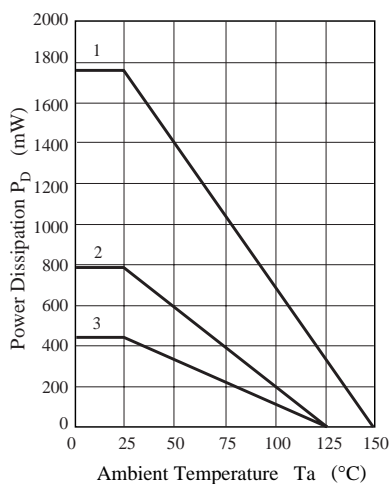

- 1) AN7510: $R_{thj-a}=71^\circ C/W, P_D=1761mW(25^\circ C)$
- 2) AN7510S: $R_{thj-a}=127^\circ C/W, P_D=787mW(25^\circ C)$
Glass epoxy PCB(75mm×75mm×0.8mm)
- 3) AN7510S: $R_{thj-a}=233^\circ C/W, P_D=429mW(25^\circ C)$

■ Printed Board Circuit Layout

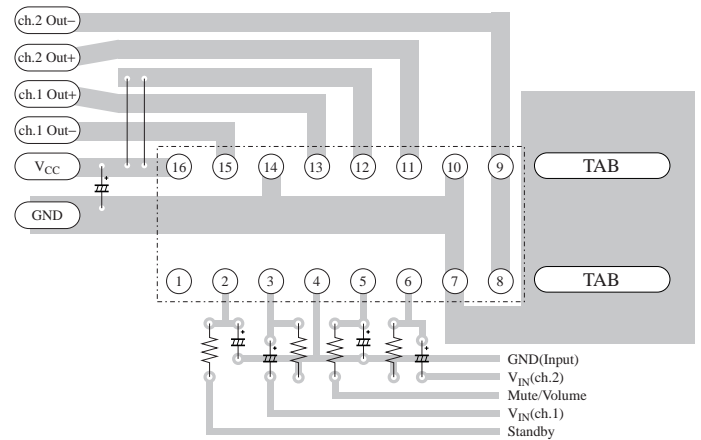

■ Pin Descriptions

Pin No.	Function
1	Standby
2	ch1 Input
3	GND(Input)
4	Mute
5	Vcc
6	ch1 Output(+)
7	GND(Output1)
8	ch1 Output(-)

■ Absolute Maximum Ratings

Parameter	Symbol	Ratio	Unit	Note
Storage temperature	T _{stg}	-55 to +150	°C	1
Operating ambient temperature	T _{opr}	-25 to +70	°C	1
Supply voltage	V _{cc}	14	V	2
Supply current	I _{cc}	1.0	A	
Power dissipation	PD	AN7511 541 AN7511S 245	mW	T _a =70°C

Note1) T_a=25°C except storage temperature and operating ambient temperature.

Note2) At no-signal.

■ Operating Supply Voltage Range

Operating supply voltage range	V _{cc}	3.5V to 13.5V
--------------------------------	-----------------	---------------

■ Electrical Characteristics ($V_{CC}=5.0V, R_L=8\Omega, \text{freq}=1\text{kHz}, T_a=25^\circ\text{C} \pm 2^\circ\text{C}$)

Parameter	Symbol	Condition	min.	typ.	max.	Unit	Note
Quiescent current	ICQ	$V_{IN}=0\text{mV}$	–	30	60	mA	
Standby current	ISTB	$V_{IN}=0\text{mV}$	–	1	10	μA	
Output noise voltage	VNO	$R_g=10\text{k}\Omega$	–	0.14	0.4	mVrms	1
Voltage gain	Gv	$P_o=0.25\text{W}$	32	34	36	dB	
Total harmonic distortion	THD	$P_o=0.25\text{W}$	–	0.05	0.5	%	
Maximum power output	PO	THD=10%	0.8	1.1	–	W	
Ripple rejection ratio	RR	$R_g=10\text{k}\Omega$ $V_r=1\text{Vrms}, f_r=120\text{Hz}$	30	50	–	dB	1
Output offset voltage	Voff	$R_g=10\text{k}\Omega$	-300	0	300	mV	
Muting effect	MT	$P_o=0.25\text{W}$	70	86	–	dB	1

Note1) For this measurement, use the filter <Bandwidth: 15Hz to 30kHz(12dB/octave)>

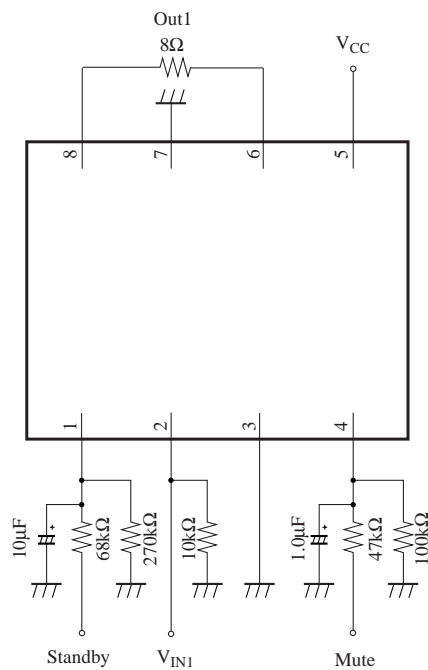
■ Application Circuit

■ Characteristic Curve(AN7511)

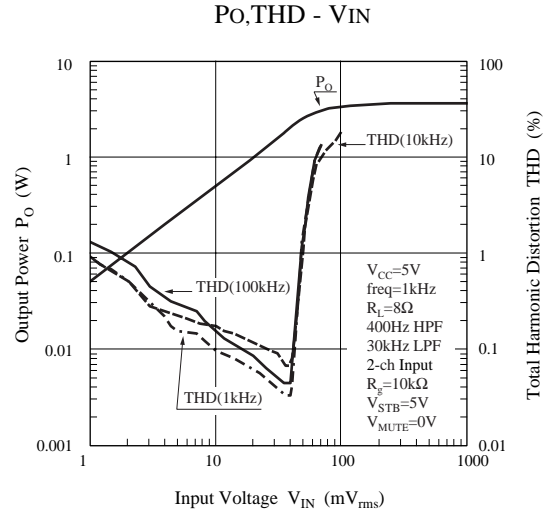
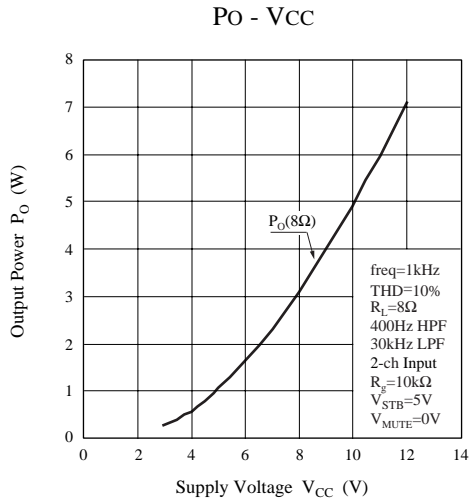

■ Package Power Dissipation

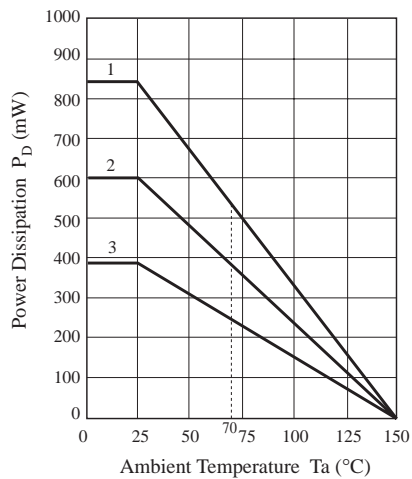

- 1) AN7511: $R_{thj-a}=148^\circ C/W, P_D=845mW(25^\circ C)$
- 2) AN7511S: $R_{thj-a}=209.3^\circ C/W, P_D=597mW(25^\circ C)$
Glass epoxy PCB(50mm×50mm×0.8mm)
- 3) AN7511S: $R_{thj-a}=326.6^\circ C/W, P_D=383mW(25^\circ C)$

■ Printed Board Circuit Layout

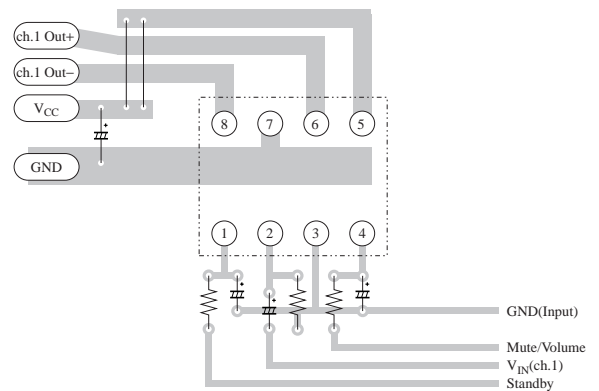

AN7512, AN7512S

Dual 0.5,1W BTL Audio Power Amplifier Circuit

■ Features

- AN7512: $V_{CC}=5V, Output=1W(8\Omega)$
- AN7512S: $V_{CC}=5V, Output=0.5W(16\Omega)$
- Built-in Standby function.
- Built-in DC volume circuits.

■ Applications

- TVs, Audio equipment, Personal computers, Active speakers

■ Block Diagram

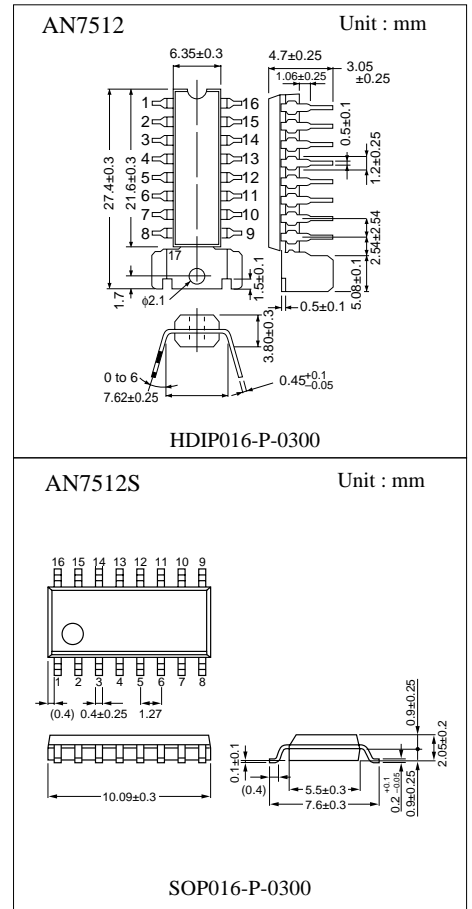
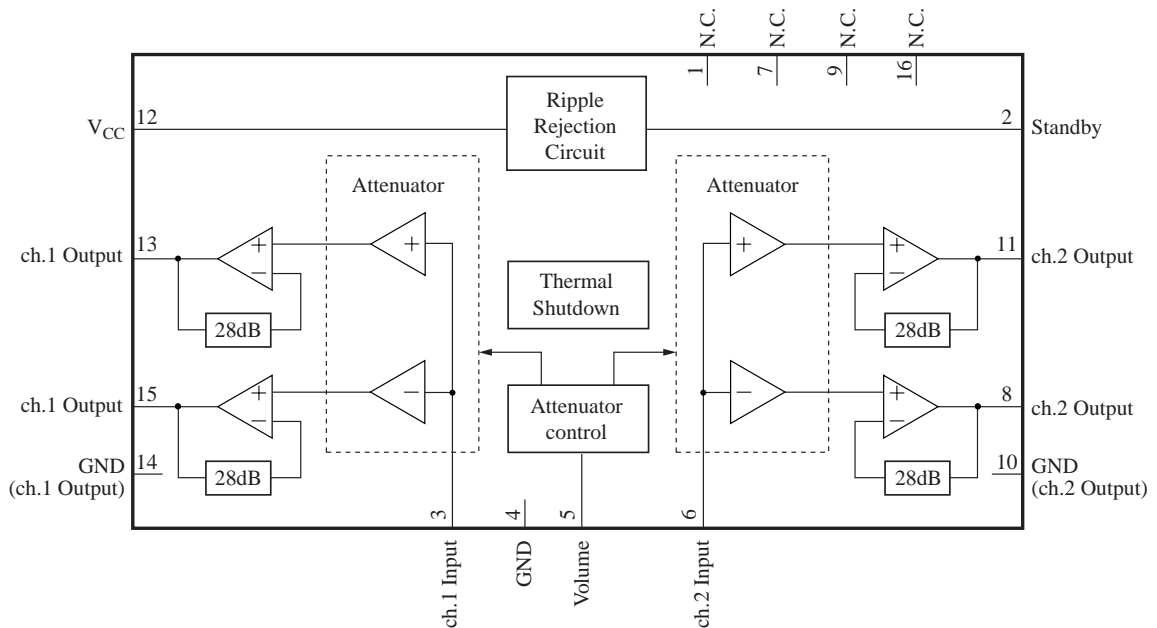

■ Pin Descriptions

Pin No.	Function	Pin No.	Function
1	N.C	9	N.C
2	Standby	10	GND(Output ch2)
3	ch1 Input	11	ch2 Output(+)
4	GND(Input)	12	Vcc
5	DC volume	13	ch1 Output(+)
6	ch2 Input	14	GND(Output ch1)
7	N.C	15	ch1 Output(-)
8	ch2 Output(-)	16	N.C

■ Absolute Maximum Ratings

Parameter	Symbol	Ratio	Unit	Note
Storage temperature	T _{stg}	AN7512 -55 to +150	°C	1
		AN7512S -55 to +125		
Operating ambient temperature	T _{opr}	-25 to +70	°C	1
Supply voltage	V _{cc}	14	V	2
Supply current	I _{cc}	2.0	A	
Power dissipation	P _D	AN7512 1127	mW	Ta=70°C
		AN7512S 236		

Note1) Ta=25°C except storage temperature and operating ambient temperature.

Note2) At no-signal.

■ Operating Supply Voltage Range

Operating supply voltage range	V _{cc}	3.5V to 13.5V
--------------------------------	-----------------	---------------

■ Electrical Characteristics ($V_{CC}=5.0V, R_L=8\Omega, \text{freq}=1\text{kHz}, T_a=25^\circ\text{C} \pm 2^\circ\text{C}$)

Parameter	Symbol	Condition	min.	typ.	max.	Unit	Note
Quiescent current	ICQ	$V_{IN}=0\text{mV}, \text{Vol.}=0\text{V}$	–	35	100	mA	
Standby current	ISTB	$V_{IN}=0\text{mV}, \text{Vol.}=0\text{V}$	–	1	10	μA	
Output noise voltage	VNO	$R_g=10\text{k}\Omega, \text{Vol.}=0\text{V}$	–	0.10	0.4	mVrms	1
Voltage gain	GV	$P_o=0.25\text{W}, \text{Vol.}=1.25\text{V}$	32	34	36	dB	
Total harmonic distortion	THD	$P_o=0.25\text{W}, \text{Vol.}=1.25\text{V}$	–	0.10	0.5	%	
Maximum power output	Po	$\text{THD}=10\%, \text{Vol.}=1.25\text{V}$	0.8	1.1	–	W	
Ripple rejection ratio	RR	$R_g=10\text{k}\Omega, \text{Vol.}=0\text{V}$ $V_r=0.5\text{Vrms}, \text{fr}=120\text{Hz}$	30	50	–	dB	1
Output offset voltage	V _{off}	$R_g=10\text{k}\Omega, \text{Vol.}=0\text{V}$	-250	0	250	mV	
Maximum attenuation	Att	$P_o=0.25\text{W}, \text{Vol.}=0\text{V}$	70	90	–	dB	1
Input impedance	ZI	$V_{IN}=\pm 0.3\text{VDC}$	24	30	36	$\text{k}\Omega$	
Channel balance1	CB1	$P_o=0.25\text{W}, \text{Vol.}=1.25\text{V}$	-1	0	1	dB	
Channel balance2	CB2	$P_o=0.25\text{W}, \text{Vol.}=0.6\text{V}$	-3	0	3	dB	
Center voltage gain	G _{VM}	$P_o=0.25\text{W}, \text{Vol.}=0.6\text{V}$	22	25	28	dB	
Channel crosstalk	CT	$P_o=0.25\text{W}, \text{Vol.}=1.25\text{V}$	40	55	–	dB	

Note1) For this measurement, use the filter <Bandwidth: 15Hz to 30kHz(12dB/octave)>

■ Application Circuit

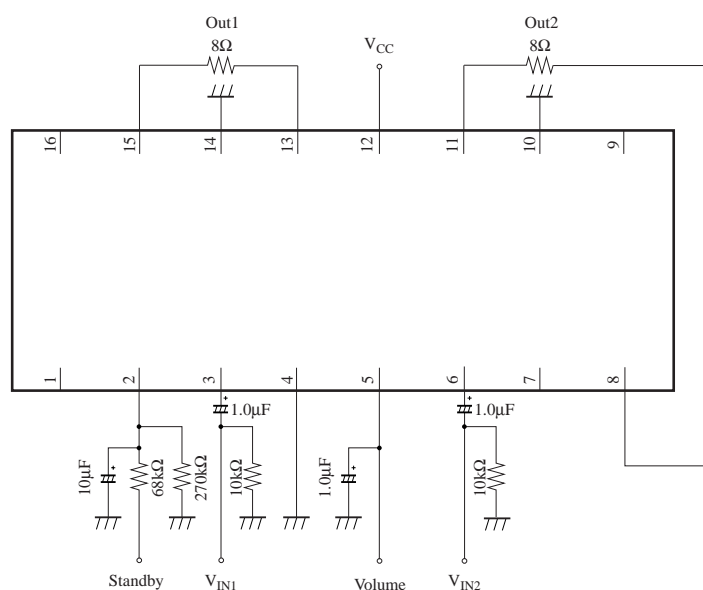

■ Package Power Dissipation

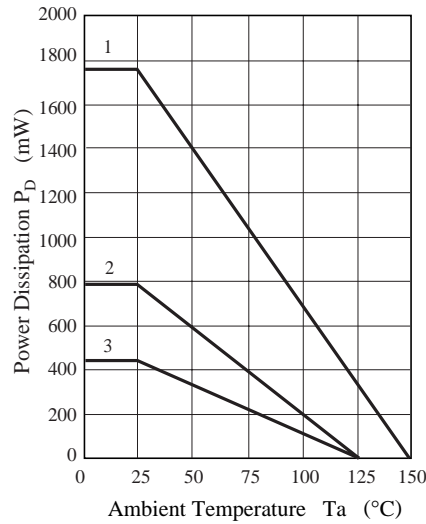

- 1) AN7512: $R_{thj-a}=71^{\circ}\text{C}/\text{W}, P_D=1761\text{mW}(25^{\circ}\text{C})$
- 2) AN7512S: $R_{thj-a}=127^{\circ}\text{C}/\text{W}, P_D=787\text{mW}(25^{\circ}\text{C})$
Glass epoxy PCB(75mm×75mm×0.8mm)
- 3) AN7512S: $R_{thj-a}=233^{\circ}\text{C}/\text{W}, P_D=429\text{mW}(25^{\circ}\text{C})$

■ Printed Board Circuit Layout

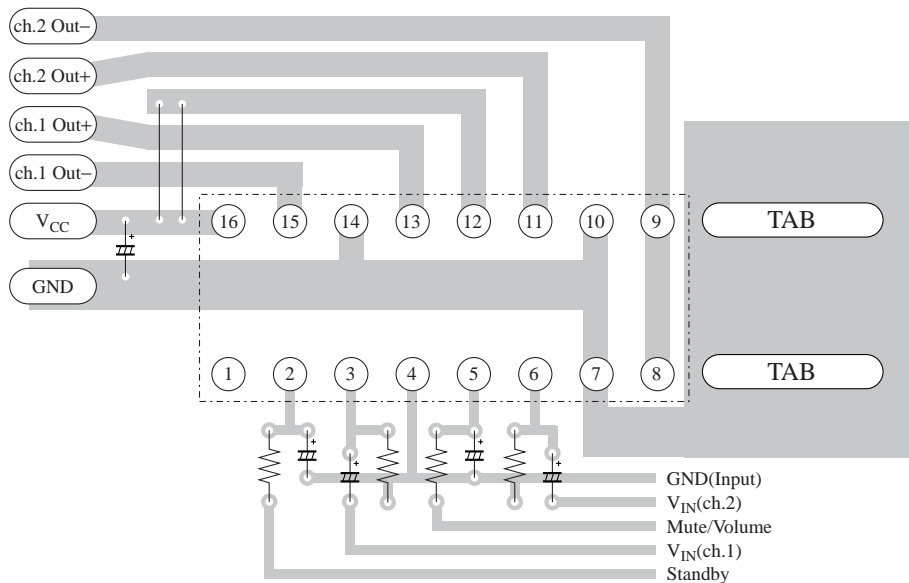

AN7513, AN7513S

0.5,1W BTL Audio Power Amplifier Circuit

■ Features

- AN7513: $V_{cc}=5V, Output=1W(8\Omega)$
- AN7513S: $V_{cc}=5V, Output=0.5W(16\Omega)$
- Built-in Standby function.
- Built-in DC volume circuits.

■ Applications

- TVs, Audio equipment, Personal computers

■ Block Diagram

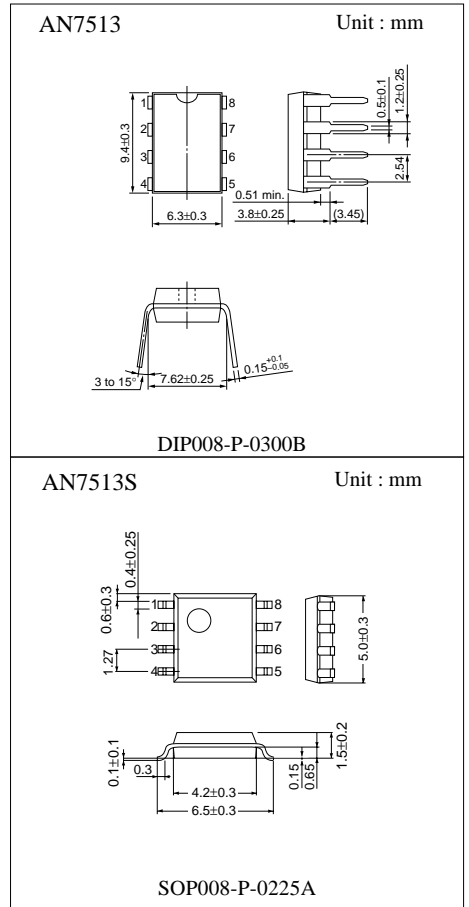
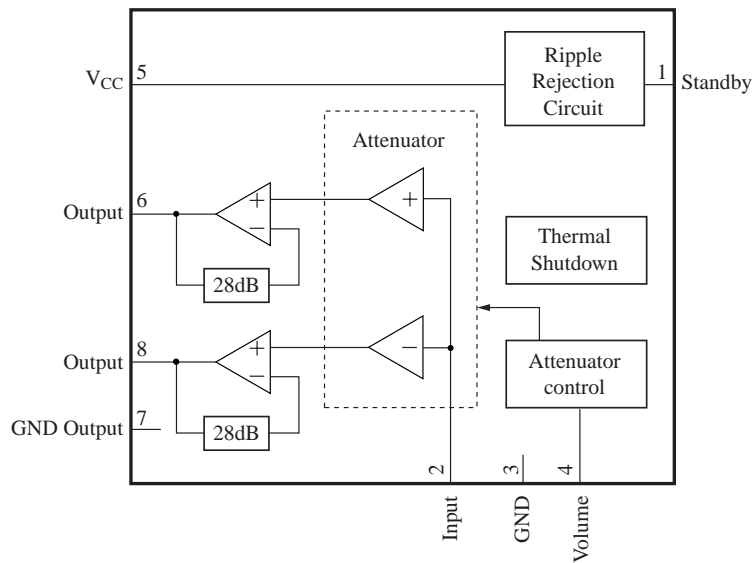

■ Pin Descriptions

Pin No.	Function
1	Standby
2	ch1 Input
3	GND(Input)
4	DC volume
5	Vcc
6	ch1 Output(+)
7	GND(Output1)
8	ch1 Output(-)

■ Absolute Maximum Ratings

Parameter	Symbol	Ratio	Unit	Note
Storage temperature	T _{stg}	-55 to +150	°C	1
Operating ambient temperature	T _{opr}	-25 to +70	°C	1
Supply voltage	V _{cc}	14	V	2
Supply current	I _{cc}	1.0	A	
Power dissipation	P _D	AN7513 541 AN7513S 245	mW	T _a =70°C

Note1) T_a=25°C except storage temperature and operating ambient temperature.

Note2) At no-signal.

■ Operating Supply Voltage Range

Operating supply voltage range	V _{cc}	3.5V to 13.5V
--------------------------------	-----------------	---------------

■ Electrical Characteristics ($V_{CC}=5.0V, R_L=8\Omega, \text{freq}=1\text{kHz}, T_a=25^\circ\text{C} \pm 2^\circ\text{C}$)

Parameter	Symbol	Condition	min.	typ.	max.	Unit	Note
Quiescent current	ICQ	$V_{IN}=0\text{mV}, \text{Vol.}=0\text{V}$	–	20	60	mA	
Standby current	ISTB	$V_{IN}=0\text{mV}, \text{Vol.}=0\text{V}$	–	1	10	μA	
Output noise voltage	VNO	$R_g=10\text{k}\Omega, \text{Vol.}=0\text{V}$	–	0.10	0.4	mVrms	1
Voltage gain	GV	$P_O=0.25\text{W}, \text{Vol.}=2.5\text{V}$	31	33	35	dB	
Total harmonic distortion	THD	$P_O=0.25\text{W}, \text{Vol.}=2.5\text{V}$	–	0.10	0.5	%	
Maximum power output	PO	$\text{THD}=10\%, \text{Vol.}=2.5\text{V}$	0.7	1.0	–	W	
Ripple rejection ratio	RR	$R_g=10\text{k}\Omega, \text{Vol.}=0\text{V}$ $V_r=1.0\text{Vrms}, f_r=120\text{Hz}$	30	50	–	dB	1
Output offset voltage	Voff	$R_g=10\text{k}\Omega, \text{Vol.}=0\text{V}$	-250	0	250	mV	
Maximum attenuation	Att	$P_O=0.25\text{W}, \text{Vol.}=0\text{V}$	70	85	–	dB	1
Center voltage gain	GVM	$P_O=0.25\text{W}, \text{Vol.}=0.1.25\text{V}$	20.5	23.5	26.5	dB	

Note1) For this measurement, use the filter <Bandwidth: 15Hz to 30kHz(12dB/octave)>

■ Application Circuit

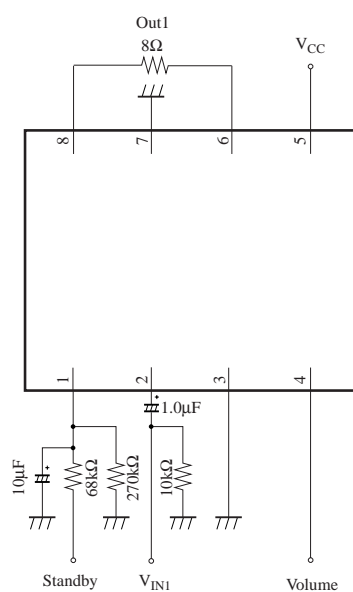

■ Package Power Dissipation

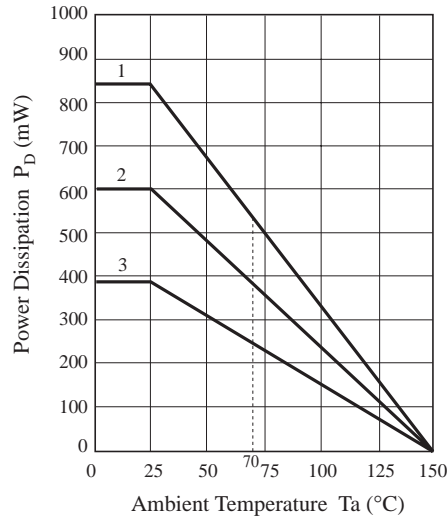

- 1) AN7513: $R_{thj-a}=148^{\circ}\text{C}/\text{W}, P_D=845\text{mW}(25^{\circ}\text{C})$
- 2) AN7513S: $R_{thj-a}=209.3^{\circ}\text{C}/\text{W}, P_D=597\text{mW}(25^{\circ}\text{C})$
Glass epoxy PCB(50mm×50mm×0.8mm)
- 3) AN7513S: $R_{thj-a}=326.6^{\circ}\text{C}/\text{W}, P_D=383\text{mW}(25^{\circ}\text{C})$

■ Printed Board Circuit Layout

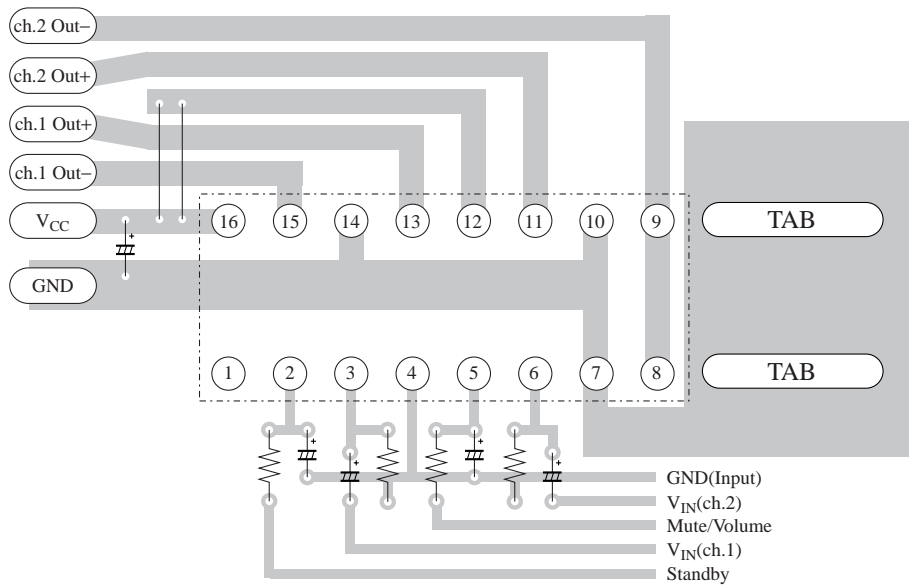

AN7522

Dual 3W BTL Audio Power Amplifier Circuit

■ Features

- $V_{cc}=8V$, Output=3W(8Ω)
- Built-in Standby function.
- Built-in DC volume circuits.

■ Applications

- TVs, Audio equipment, Personal computers, Active speakers

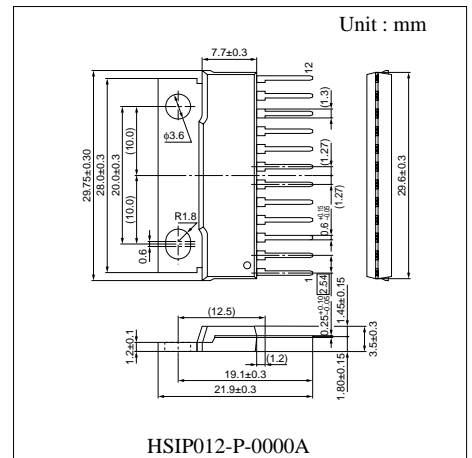

■ Block Diagram

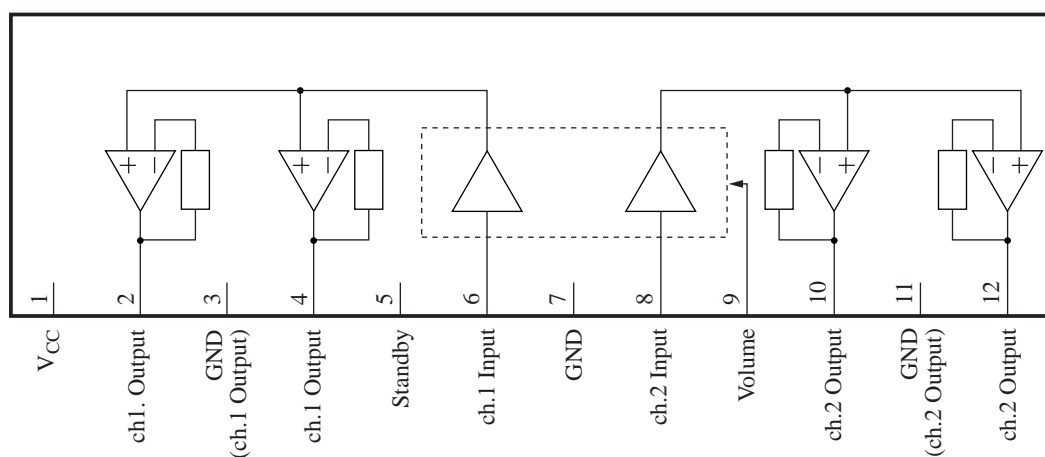

■ Pin Descriptions

Pin No.	Function	Pin No.	Function
1	Vcc	7	GND(Input)
2	ch1 Output(+)	8	ch2 Input
3	GND(Output ch1)	9	DC Volume
4	ch1 Output(-)	10	ch2 Output(-)
5	Standby	11	GND(Output ch2)
6	ch1 Input	12	ch2 Output(+)

■ Absolute Maximum Ratings

Parameter	Symbol	Ratio	Unit	Note
Storage temperature	T _{stg}	-55 to +150	°C	1
Operating ambient temperature	T _{opr}	-25 to +70	°C	1
Supply voltage	V _{cc}	14	V	2
Supply current	I _{cc}	2.0	A	
Power dissipation	PD	1920	mW	T _a =70°C

Note1) T_a=25°C except storage temperature and operating ambient temperature.

Note2) At no-signal.

■ Operating Supply Voltage Range

Operating supply voltage range	V _{cc}	3.5V to 13.5V
--------------------------------	-----------------	---------------

■ Electrical Characteristics ($V_{CC}=5.0V, R_L=8\Omega, \text{freq}=1\text{kHz}, T_a=25^\circ\text{C} \pm 2^\circ\text{C}$)

Parameter	Symbol	Condition	min.	typ.	max.	Unit	Note
Quiescent current	ICQ	$V_{IN}=0\text{mV}, \text{Vol.}=0\text{V}$	–	45	100	mA	
Standby current	ISTB	$V_{IN}=0\text{mV}, \text{Vol.}=0\text{V}$	–	1	10	μA	
Output noise voltage	VNO	$R_g=10\text{k}\Omega, \text{Vol.}=0\text{V}$	–	0.10	0.4	mVrms	1
Voltage gain	GV	$P_o=0.25\text{W}, \text{Vol.}=1.25\text{V}$	32	34	36	dB	
Total harmonic distortion	THD	$P_o=0.25\text{W}, \text{Vol.}=1.25\text{V}$	–	0.10	0.5	%	
Maximum power output	Po	$\text{THD}=10\%, \text{Vol.}=1.25\text{V}$	2.4	3.0	–	W	
Ripple rejection ratio	RR	$R_g=10\text{k}\Omega, \text{Vol.}=0\text{V}$ $V_r=0.5\text{Vrms}, f_r=120\text{Hz}$	30	50	–	dB	1
Output offset voltage	Voff	$R_g=10\text{k}\Omega, \text{Vol.}=0\text{V}$	-250	0	250	mV	
Maximum attenuation	Att	$P_o=0.25\text{W}, \text{Vol.}=0\text{V}$	70	90	–	dB	1
Input impedance	ZI	$V_{IN}=\pm 0.3\text{VDC}$	24	30	36	$\text{k}\Omega$	
Channel balance1	CB1	$P_o=0.25\text{W}, \text{Vol.}=1.25\text{V}$	-1	0	1	dB	
Channel balance2	CB2	$P_o=0.25\text{W}, \text{Vol.}=0.6\text{V}$	-3	0	3	dB	
Center voltage gain	GVM	$P_o=0.25\text{W}, \text{Vol.}=0.6\text{V}$	21	24	27	dB	
Channel crosstalk	CT	$P_o=0.25\text{W}, \text{Vol.}=1.25\text{V}$	44	55	–	dB	

Note1) For this measurement, use the filter <Bandwidth: 15Hz to 30kHz(12dB/octave)>

■ Application Circuit

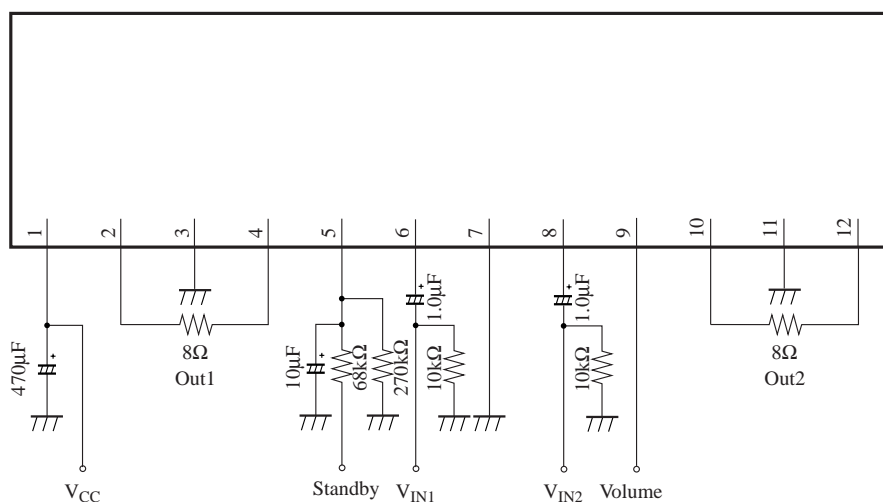

■ Characteristic Curve

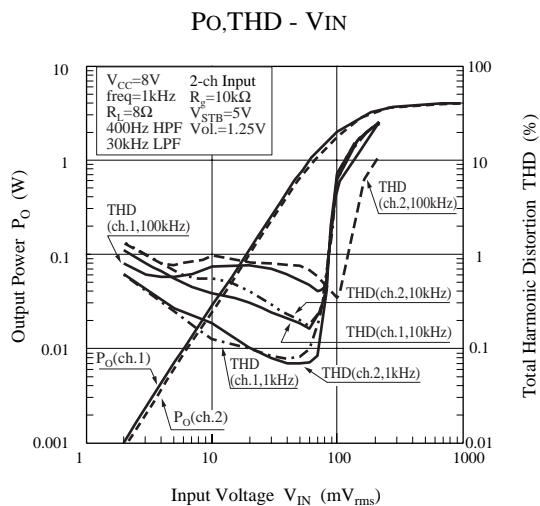
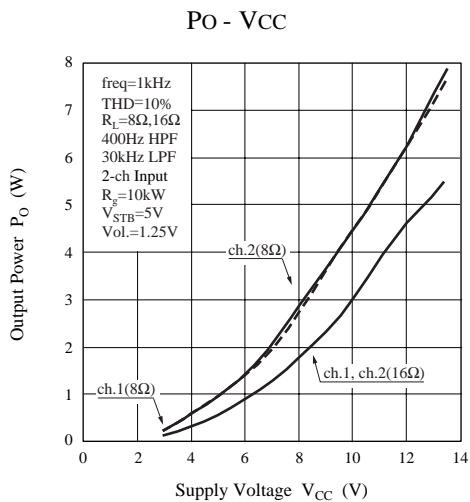

■ Package Power Dissipation

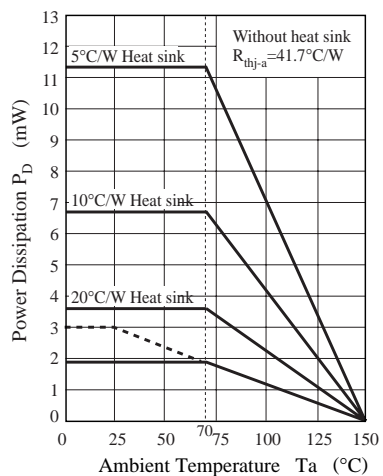

■ Printed Board Circuit Layout

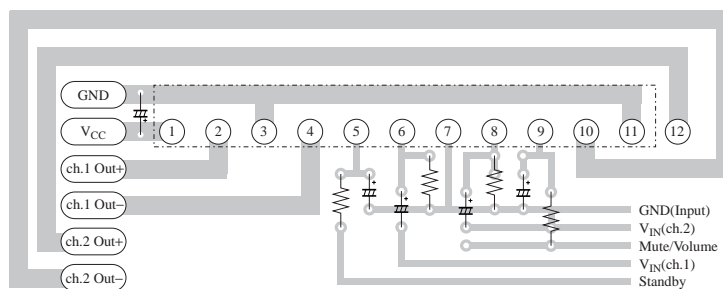

AN7523

3W BTL Audio Power Amplifier Circuit

■ Features

- $V_{CC}=8V, Output=3W(8\Omega)$
- Built-in Standby function.
- Built-in DC volume circuits.

■ Applications

- TVs, Audio equipment

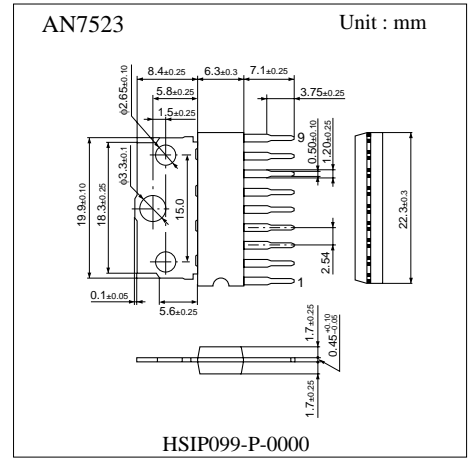

■ Block Diagram

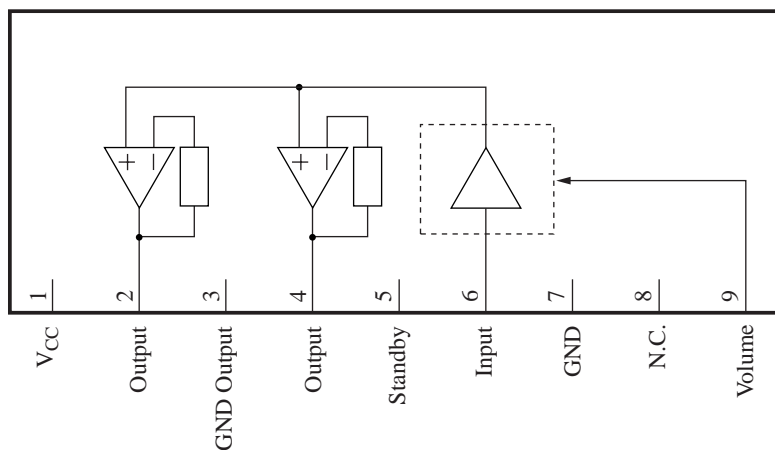

■ Pin Descriptions

Pin No.	Function
1	Vcc
2	ch1 Output(+)
3	GND(Output1)
4	ch1 Output(-)
5	Standby
6	ch1 Input
7	GND
8	N.C
9	DC volume

■ Absolute Maximum Ratings

Parameter	Symbol	Ratio	Unit	Note
Storage temperature	T _{stg}	-55 to +150	°C	1
Operating ambient temperature	T _{opr}	-25 to +70	°C	1
Supply voltage	V _{cc}	14	V	2
Supply current	I _{cc}	1.0	A	
Power dissipation	P _D	1220	mW	T _a =70°C

Note1) T_a=25°C except storage temperature and operating ambient temperature.

Note2) At no-signal.

■ Operating Supply Voltage Range

Operating supply voltage range	V _{cc}	3.5V to 13.5V
--------------------------------	-----------------	---------------

■ Electrical Characteristics ($V_{CC}=5.0V, R_L=8\Omega, \text{freq}=1\text{kHz}, T_a=25^\circ\text{C} \pm 2^\circ\text{C}$)

Parameter	Symbol	Condition	min.	typ.	max.	Unit	Note
Quiescent current	ICQ	$V_{IN}=0\text{mV}, V_{ol}=0\text{V}$	–	25	60	mA	
Standby current	ISTB	$V_{IN}=0\text{mV}, V_{ol}=0\text{V}$	–	1	10	μA	
Output noise voltage	VNO	$R_g=10\text{k}\Omega, V_{ol}=0\text{V}$	–	0.10	0.4	mVrms	1
Voltage gain	GV	$P_o=0.25\text{W}, V_{ol}=1.25\text{V}$	31	33	35	dB	
Total harmonic distortion	THD	$P_o=0.25\text{W}, V_{ol}=1.25\text{V}$	–	0.10	0.5	%	
Maximum power output	PO	$\text{THD}=10\%, V_{ol}=1.25\text{V}$	2.4	3.0	–	W	
Ripple rejection ratio	RR	$R_g=10\text{k}\Omega, V_{ol}=0\text{V}$ $V_r=0.5\text{Vrms}, f_r=120\text{Hz}$	30	50	–	dB	1
Output offset voltage	Voff	$R_g=10\text{k}\Omega, V_{ol}=0\text{V}$	-250	0	250	mV	
Maximum attenuation	Att	$P_o=0.5\text{W}, V_{ol}=0\text{V}$	70	85	–	dB	1
Center voltage gain	GVM	$P_o=0.5\text{W}, V_{ol}=0.6\text{V}$	20.5	23.5	26.5	dB	
Standby terminal current	ISTB	$V_{IN}=0\text{mV}, V_{STB}=3\text{V}$	–	–	25	μA	
Volume terminal current	Ivol	$V_{IN}=0\text{mV}, V_{ol}=0\text{V}$	-12	–	–	μA	

Note1) For this measurement, use the filter <Bandwidth: 15Hz to 30kHz(12dB/octave)>

■ Application Circuit

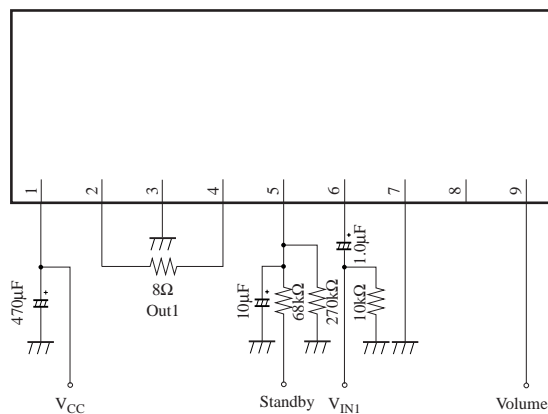

■ Characteristic Curve

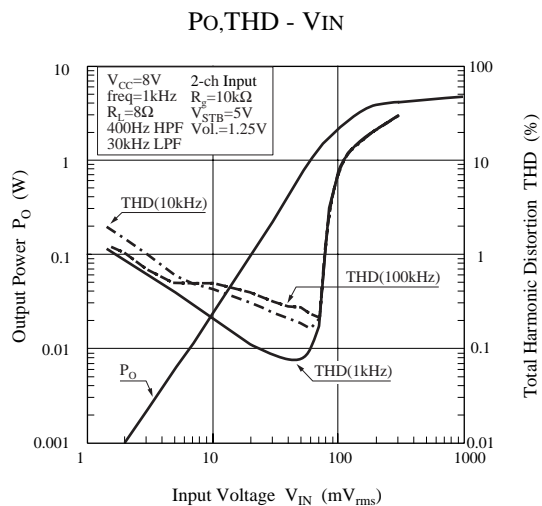
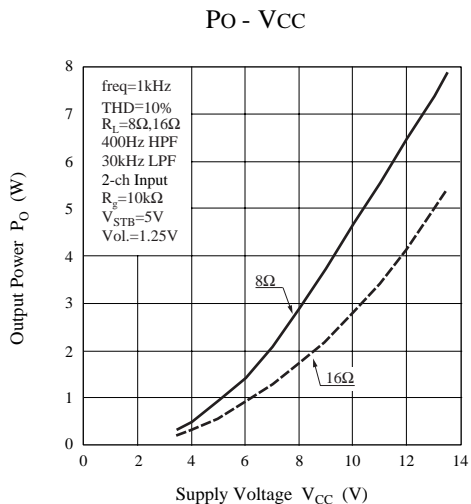

■ Package Power Dissipation

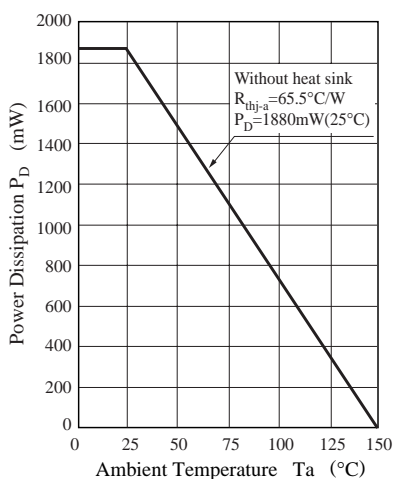

■ Printed Board Circuit Layout

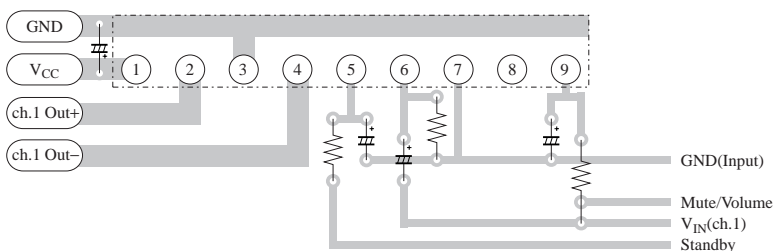



LittleDiode supplies new, hard to find or obsolete electronic components and semiconductors all over the world.

With over two million different components listed you are sure to find the part you need.

Feel free to visit us today at our online store:

LittleDiode.com

Looking forward to providing you with the best possible service.