

AN7504SB

Pre-amp. and power amp. IC for 1.5 V headphone stereo

■ Overview

The AN7504SB is a low voltage operation headphone amp. IC for headphone C-cassette stereo. It incorporates tape selector, pre-amp. , soft AGC bass-boost circuit, etc.

■ Features

- Low voltage operation (0.98 V to 2.0 V)
- Tape selector switch built-in
- Low frequency boost function with soft AGC

■ Applications

- Headphone stereo

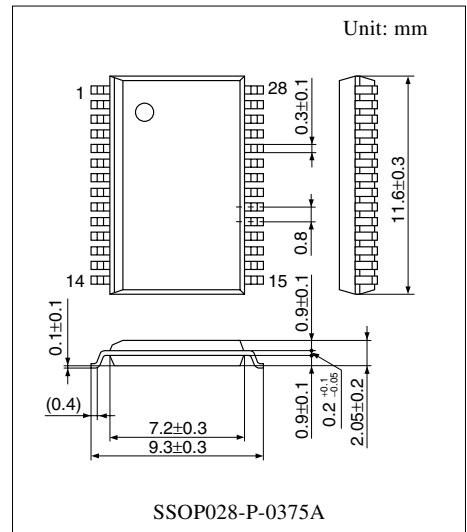

Note) The package of this product will be changed to lead-free type (SSOP028-P-0375E). See the new package dimensions section later of this datasheet.

■ Block Diagram

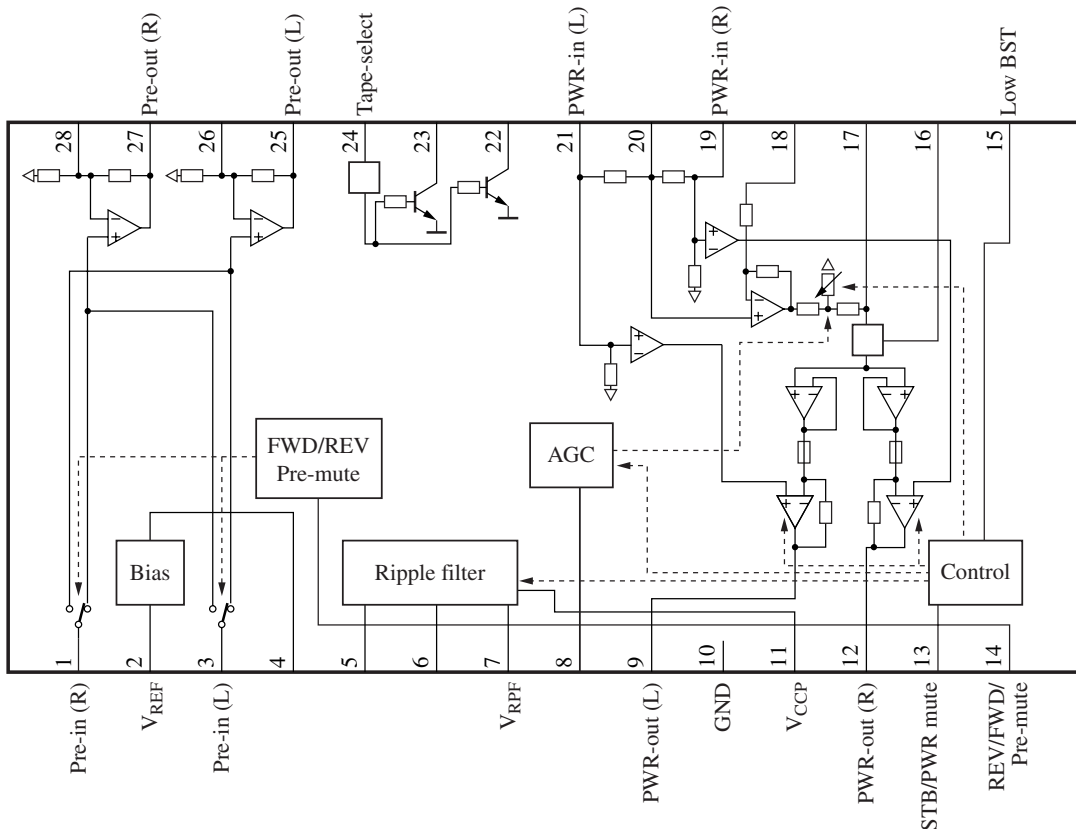

■ Absolute Maximum Ratings

Parameter	Symbol	Rating	Unit
Supply voltage	V_{CC}	2.1	V
Supply current	I_{CC}	20	mA
Power dissipation *2	P_D	42	mW
Operating ambient temperature *1	T_{opr}	-20 to +70	°C
Storage temperature *1	T_{stg}	-55 to +125	°C

Note) *1: Except for the operating ambient temperature and storage temperature, all ratings are for $T_a = 25^\circ\text{C}$.

Keep V_{CC} (0.95 V to 0.98 V) free from any abnormal operation such as oscillation.

*2: The power dissipation shown is the value for $T_a = 75^\circ\text{C}$. For the independent IC without a heat sink.

■ Recommended Operating Range

Parameter	Symbol	Range	Unit
Supply voltage	V_{CC}	0.98 to typ. 1.2 to 2.0	V

■ Electrical Characteristics at $V_{CC} = 1.2\text{ V}$, $f = 1\text{ kHz}$, $R_L = 32\ \Omega$, $T_a = 25^\circ\text{C}$

Parameter	Symbol	Conditions	Min	Typ	Max	Unit
Voltage gain	G_V	$V_O = -22.2\text{ dBV}$	54	57	60	dB
Circuit current 1	I_{CC1}	$V_{IN} = 0$, $R_G = 2.2\text{ k}\Omega$, LBST off	—	2.2	5.3	mA
Pre-amp. block						
Closed circuit voltage gain	$G_{VC(PB)}$	$V_O = -22.2\text{ dBV}$	32.5	34	35.5	dB
Max. output voltage	$V_{Omax(PB)}$	THD = 1%, 30 kHz LPF on	120	210	—	mV
Total harmonic distortion	THD _(PB)	$V_O = 22.2\text{ dBV}$, 30 kHz LPF on $G_{VC} = 35\text{ dB}$ (NAB)	—	0.2	0.6	%
Output noise voltage	$V_{NO(PB)}$	$R_G = 2.2\text{ k}\Omega$, 1HF-A	—	-90	-76	dBV
Mute attenuation	$G_{MUTE(PB)}$	Ratio as $V_O = -22.2\text{ dBV}$ Pre-mute on	—	-85	-70	dB
Boost low sound and power amp. block						
Voltage gain 1	$G_{V1(PW)}$	$V_O = -22.2\text{ dBV}$	21	23	25	dB
Voltage gain 2	$G_{V2(PW)}$	LBOOST on, $V_O = -22.2\text{ dBV}$	21.4	23.4	25.4	dB
Rating output power	P_{OUT}	THD = 10%, 30 kHz LPF on	2.5	4.5	—	mW
Total harmonic distortion	THD _(PW)	$P_{OUT} = 1\text{ mW}$, 30 kHz LPF on	—	0.35	1.3	%
Output noise voltage 1	$V_{NO1(PW)}$	$R_G = 0.1$, 1HF-A	—	-91	-86	dBV
Output noise voltage 2	$V_{NO2(PW)}$	LBOOST on, $R_G = 0$, 1HF-A	—	-86	-82	dBV
Channel balance	CB _(PW)	$V_O = -22.2\text{ dBV}$	-1.5	0	1.5	dB
Mute output voltage	$V_{MUTE(PW)}$	$V_{IN} = -32.2\text{ dBV}$	—	-96	-90	dBV
AGC level	V_{AGC}	$V_{IN} = -45.2\text{ dBV}$, $f = 100\text{ Hz}$ $R_L = 32\ \Omega$ AGC level: 32 Ω edge measure	-17.3	-14.7	-13.1	dBV

■ Electrical Characteristics at $V_{CC} = 1.2\text{ V}$, $f = 1\text{ kHz}$, $R_L = 32\ \Omega$, $T_a = 25^\circ\text{C}$ (continued)

Parameter	Symbol	Conditions	Min	Typ	Max	Unit
Ripple filter block						
Ripple rejection ratio	RR	$V_{CC} = 1.1\text{ V}$, $V_{RR} = -32.2\text{ dBV}$ $f_{RR} = 100\text{ Hz}$, $I_{RFO} = 15\text{ mA}$ BPF: 100 Hz, 1/4 OCT	24	30	—	dB
DC output voltage	V_{RPF}	$V_{CC} = 1.0\text{ V}$, $I_{RFO} = 15\text{ mA}$	0.89	0.94	—	V
Bias block						
DC output voltage	V_{REF}	$V_{CC} = 1.0\text{ V}$	0.68	0.76	0.83	V
Control block						
Threshold voltage at standby on	V_{STON}	Low: Power off	—	—	0.1	V
Threshold voltage at standby off	V_{STOFF}	Open: Power on (Power mute on) $V_{STOFF} = 1/2V_{CC} - V_{13}$	-0.2	—	0.2	V
Bias voltage at power mute off	V_{MTOFF}	Open: Power mute off $V_{MTOFF} = V_{CC} - V_{13}$	—	—	0.1	V
Low threshold at FWD/REV/pre-mute	V_{THIL}	Low: REV	—	—	0.1	V
High threshold at FWD/REV/pre-mute	V_{THIH}	High: Pre-mute on $V_{THIH} = V_{CC} - V_1$	—	—	0.1	V
Low threshold at low boost off	V_{LBOFF}	Low: LBOOST off	—	—	0.3	V
Low threshold at tape select off	V_{TPOFF}	Low: Tape-select off	—	—	0.3	V

• Design reference data

Note) The characteristics listed below are theoretical values based on the IC design and are not guaranteed.

Parameter	Symbol	Conditions	Min	Typ	Max	Unit
Circuit current 2	I_{CC2}	$P_{OUT} = 0.5\text{ mW}$, $\times 2\text{-ch.}$, $R_L = 32\ \Omega$	—	6.5	11.2	mA
Boost low sound and power amp. block						
Input resistance	$R_{IN(PW)}$	—	7.2	9.5	12	k Ω

■ Terminal Equivalent Circuits

Note) The values mentioned below are the typical ones and is subject to change due to application condition and dispersion of IC.

Pin No.	Equivalent circuit	Description	Waveform (typ.)
1		PB-in (R): Playback amp. input	 DC 0.78 V AC -66.2 dBV
2		V _{REF} : Reference voltage output	DC 0.78 V
3	Refer to pin 1	PB-in (L): Playback amp. input	Refer to pin 1
4	Refer to pin 2	V _{REF} -in: Reference voltage input	DC 0.78 V
5		RF-in: Ripple filter reference voltage input	DC 1.0 V
6		RF-base: Ripple filter	DC 0.47 V
7		V _{RPF} : Ripple filter reference voltage output	DC 1.13 V

■ Terminal Equivalent Circuits (continued)

Note) The values mentioned below are the typical ones and is subject to change due to application condition and dispersion of IC.

Pin No.	Equivalent circuit	Description	Waveform (typ.)
8		AGC-TAU: AGC time constant	—
9		PWR-out (L): Power amp. voltage output	 DC 0.6 V AC -8.8 dBV
10	—	GND: GND pin	0 V
11	—	V _{CC} : Power supply pin	1.2 V
12	Refer to pin 9	PWR-out (R): Power amp. voltage output	Refer to pin 9
13		STBY, PWR mute CNT: PWR-mute off Pin open: $V_{CC} - V_{13} < 0.1 \text{ V}$ PWR-mute on $-0.2 \text{ V} < 1/2V_{CC} - V_{13} < 0.2 \text{ V}$ STBY on $V_{13} < 0.1 \text{ V}$	—
14		FWD/REV/Pre-mute: FWD/REV/pre-mute control Pre-mute Voltage high: $V_{CC} - 0.1 < V_{14-19}$ FWD Pin open REV Voltage low: $V_{14-19} < 0.1$	—

■ Terminal Equivalent Circuits (continued)

Note) The values mentioned below are the typical ones and is subject to change due to application condition and dispersion of IC.

Pin No.	Equivalent circuit	Description	Waveform (typ.)
15		<p>L-BST CNT: Low boost on/off control</p> <p>L-BST on Pin open L-BST off Voltage low: $-0.3\text{ V} < V_{11-19} < 0.3\text{ V}$</p>	DC 0 V
16		<p>L-BST C: Low boost Capacitor pin</p>	<p>DC 0.78 V</p>
17		<p>LPF2-C: LPF2 Capacitor pin</p>	<p>DC 0.78 V</p>
18		<p>L-BST C1: Low boost Capacitor pin</p>	<p>DC 0.78 V</p>

■ Terminal Equivalent Circuits (continued)

Note) The values mentioned below are the typical ones and is subject to change due to application condition and dispersion of IC.

Pin No.	Equivalent circuit	Description	Waveform (typ.)
19		PWR-in (R): Power amp. input	 DC 0.78 V AC -32.2 dBV
20		LPF1-C: LPF C pin	DC 0.78 V
21		PWR-in (L): Power amp. input	Refer to pin 19
22		Tape-select on/off: Tape select driver	—
23		Tape-select on/off: Tape select driver	—
24		Tape-select on/off CNT: Tape select driver Driver on Voltage high Driver off $V_{24} < 0.3$ V	—
25	Refer to pin 1	PB-out (L): Playback amp. output	 DC 0.6 V AC -32.2 dBV

■ Terminal Equivalent Circuits (continued)

Note) The values mentioned below are the typical ones and is subject to change due to application condition and dispersion of IC.

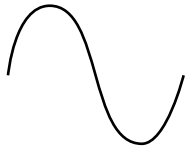
Pin No.	Equivalent circuit	Description	Waveform (typ.)
26	Refer to pin 1	PB-NF(L): Playback amp. negative feedback input	 DC 0.78 V
27	Refer to pin 1	PB-OUT(R): Playback amp. input	Refer to pin 25
28	Refer to pin 1	PB-NF(R): Playback amp. negative feedback input	Refer to pin 26

■ Application Notes

1. Operation logic of control pin

Pin 24	Low	High or Open
Tape select control	Off (Pins 22, 23 High)	On (Pins 22, 23 Low)

Pin 14	Low	Open	High
Pre-amp. system control	Reverse	Forward	Mute
	Input pin → Output pin	Input pin → Output pin	
	Pin 1 → Pin 25	Pin 1 → Pin 27	
	Pin 3 → Pin 27	Pin 3 → Pin 25	

Pin 13	Low 1	Low 2	High
Power amp. system control	Standby on	Standby off, Mute on	Mute on

Low 1: Short-circuit to GND

Low 2: 0.6 V application or short circuit to GND with 220 kΩ

■ Application Notes (continued)

2. Main characteristics

1. Pre-amp. output frequency characteristics

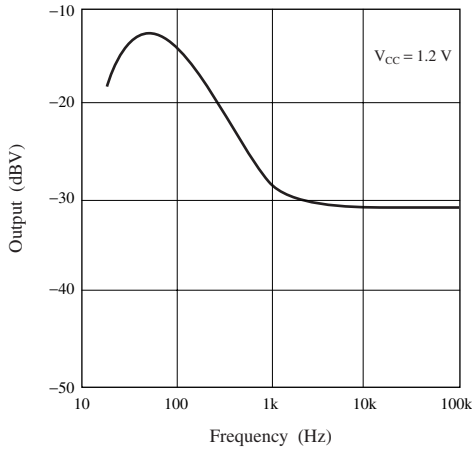

2. Distortion and amplitude at pre-amp. output

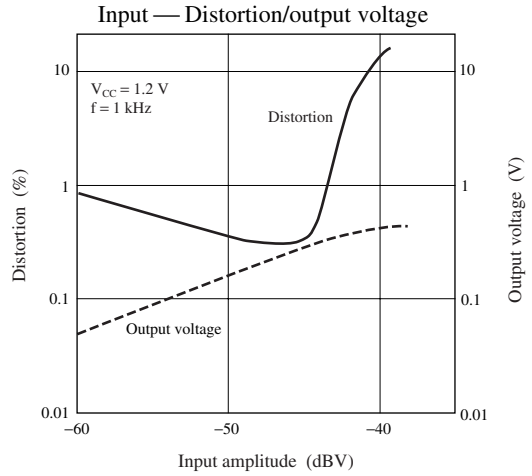

3. Distortion and amplitude characteristics of headphone amp.

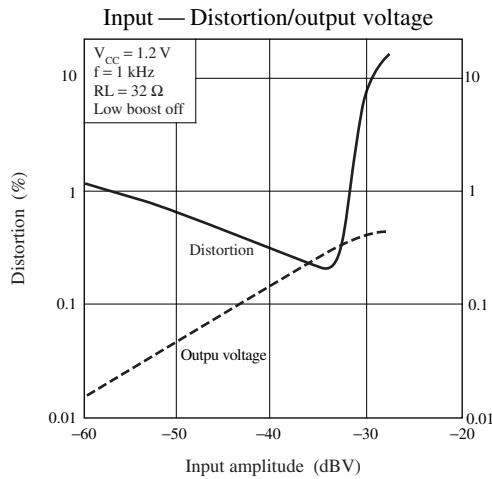

4. Headphone amp.

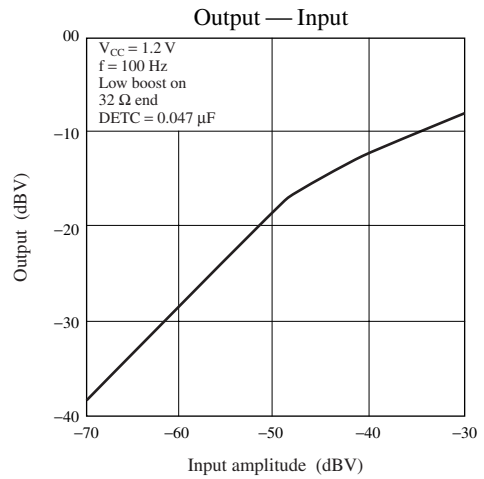

5. Headphone amp.

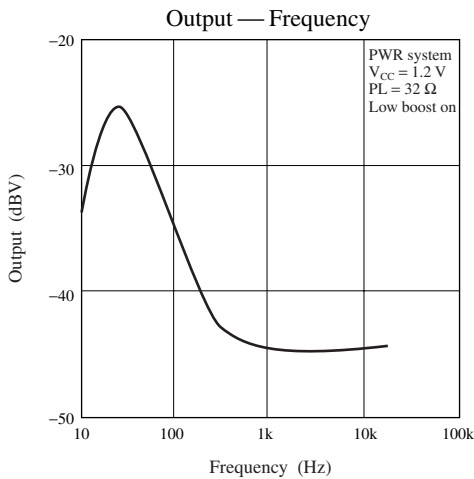

6. Distortion and amplitude at headphone amp. output

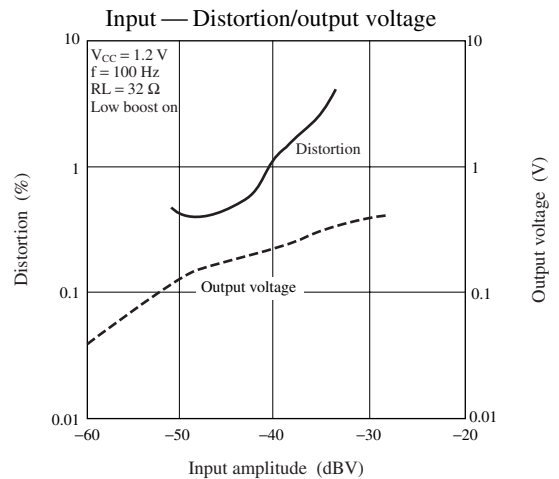

■ Application Notes (continued)

2. Main characteristics (continued)

7. Ripple filter output voltage (pin 7)

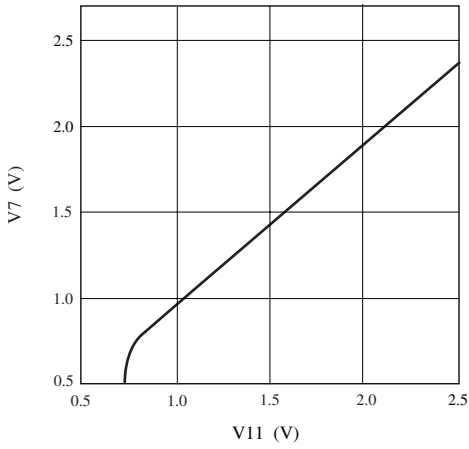

8. Ripple filter output voltage (Using at 15 mA of current)

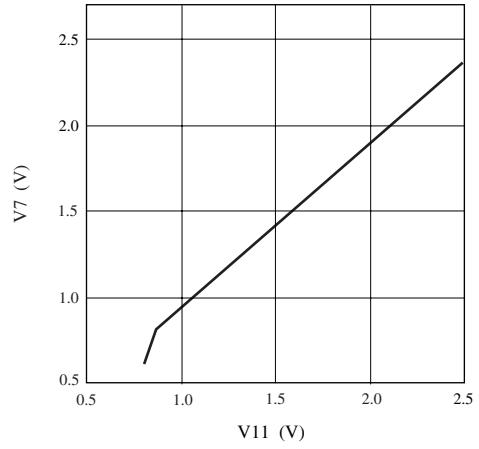

9. $V_{CC} - V_{REF}$

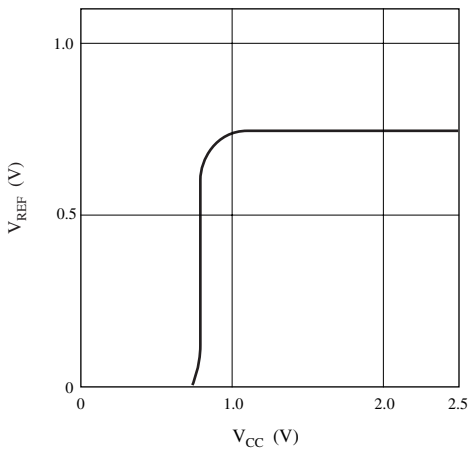

10. Pin 2 (V_{REF}) at standby on/off and voltage at pin 7 (Ripple filter)

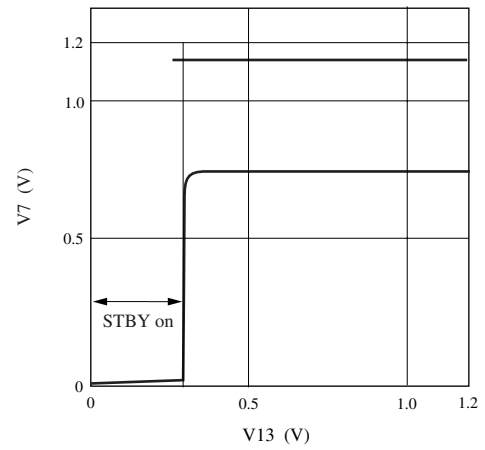

11. Headphone amp. at mute on/off (Pin 9) output voltage

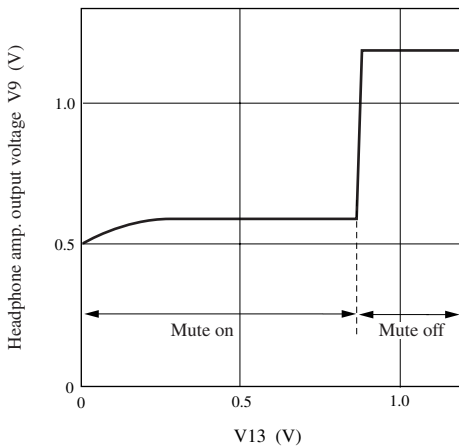

12. $V_{CC} - I_{total}$

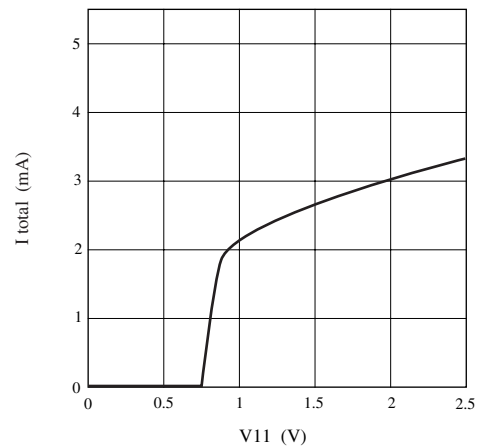

Application Circuit Examples

1. Application circuit example

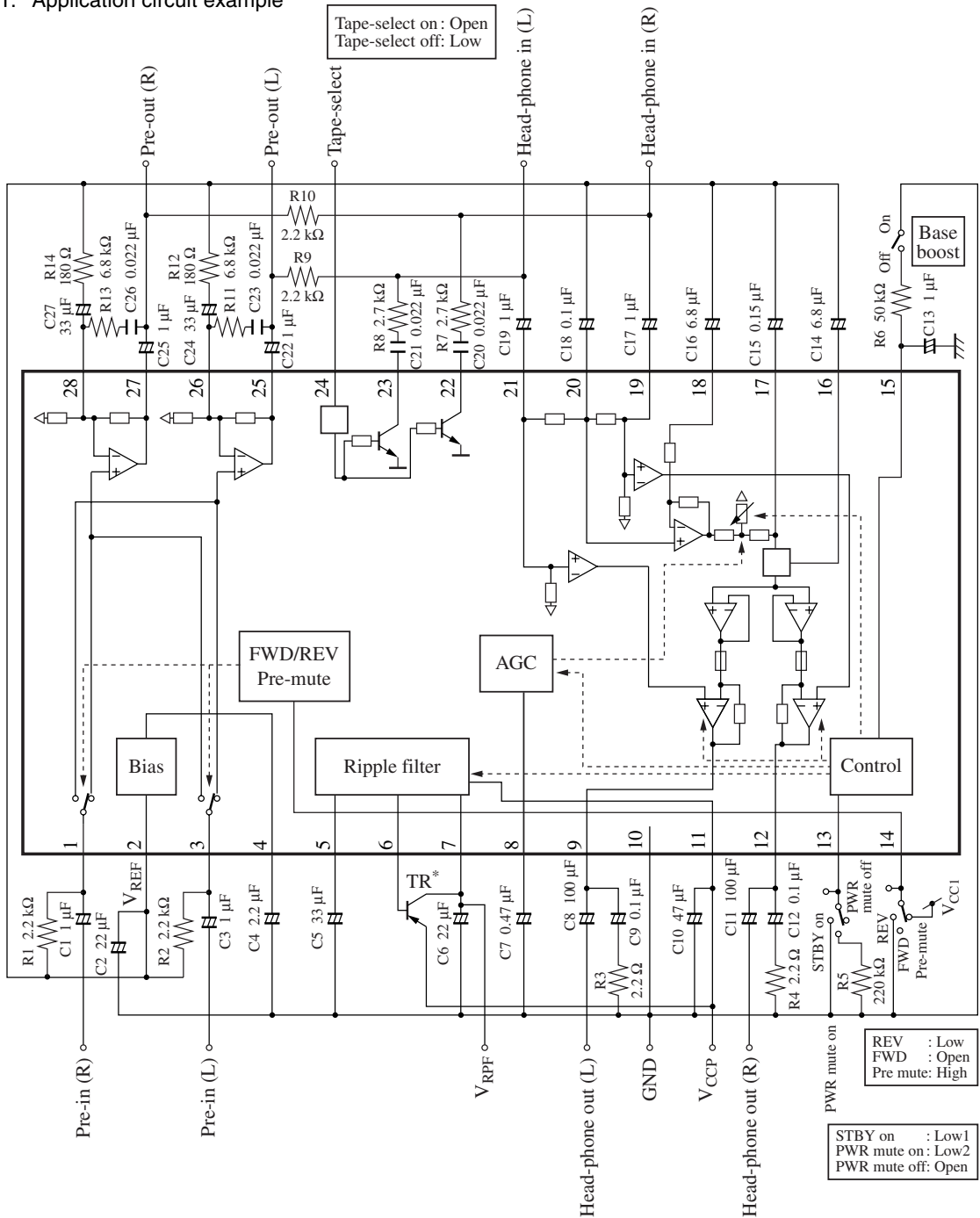

Note) *: The low $V_{CE(SAT)}$ PNP TR be used as TR.

■ Application Circuit Examples (continued)

2. Evaluation board

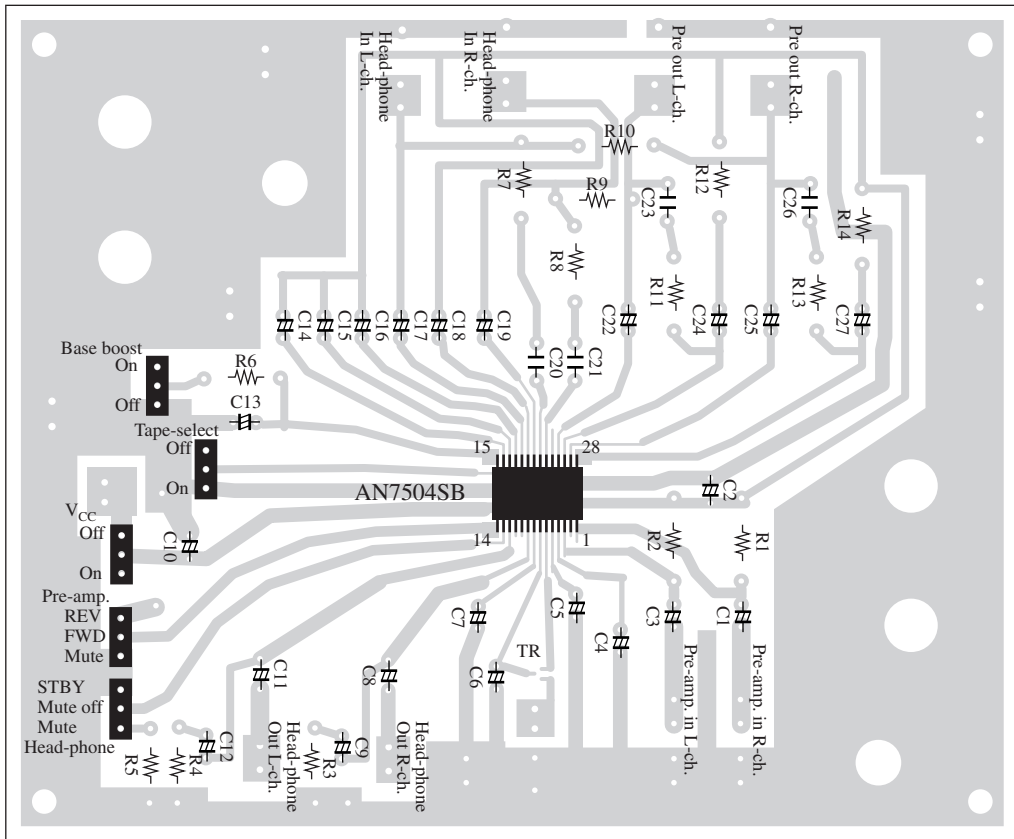

■ New Package Dimensions (Unit: mm)

- SSOP028-P-0375E (Lead-free package)

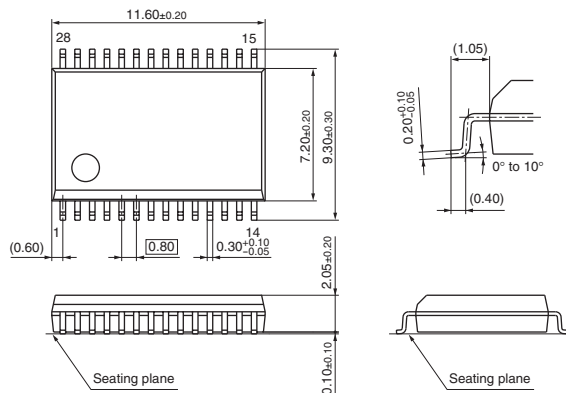

Request for your special attention and precautions in using the technical information and semiconductors described in this material

- (1) An export permit needs to be obtained from the competent authorities of the Japanese Government if any of the products or technologies described in this material and controlled under the "Foreign Exchange and Foreign Trade Law" is to be exported or taken out of Japan.
- (2) The technical information described in this material is limited to showing representative characteristics and applied circuit examples of the products. It does not constitute the warranting of industrial property, the granting of relative rights, or the granting of any license.
- (3) The products described in this material are intended to be used for standard applications or general electronic equipment (such as office equipment, communications equipment, measuring instruments and household appliances).
Consult our sales staff in advance for information on the following applications:
 - Special applications (such as for airplanes, aerospace, automobiles, traffic control equipment, combustion equipment, life support systems and safety devices) in which exceptional quality and reliability are required, or if the failure or malfunction of the products may directly jeopardize life or harm the human body.
 - Any applications other than the standard applications intended.
- (4) The products and product specifications described in this material are subject to change without notice for reasons of modification and/or improvement. At the final stage of your design, purchasing, or use of the products, therefore, ask for the most up-to-date Product Standards in advance to make sure that the latest specifications satisfy your requirements.
- (5) When designing your equipment, comply with the guaranteed values, in particular those of maximum rating, the range of operating power supply voltage and heat radiation characteristics. Otherwise, we will not be liable for any defect which may arise later in your equipment.
Even when the products are used within the guaranteed values, redundant design is recommended, so that such equipment may not violate relevant laws or regulations because of the function of our products.
- (6) When using products for which dry packing is required, observe the conditions (including shelf life and after-unpacking standby time) agreed upon when specification sheets are individually exchanged.
- (7) No part of this material may be reprinted or reproduced by any means without written permission from our company.

Please read the following notes before using the datasheets

- A. These materials are intended as a reference to assist customers with the selection of Panasonic semiconductor products best suited to their applications.
Due to modification or other reasons, any information contained in this material, such as available product types, technical data, and so on, is subject to change without notice.
Customers are advised to contact our semiconductor sales office and obtain the latest information before starting precise technical research and/or purchasing activities.
- B. Panasonic is endeavoring to continually improve the quality and reliability of these materials but there is always the possibility that further rectifications will be required in the future. Therefore, Panasonic will not assume any liability for any damages arising from any errors etc. that may appear in this material.
- C. These materials are solely intended for a customer's individual use.
Therefore, without the prior written approval of Panasonic, any other use such as reproducing, selling, or distributing this material to a third party, via the Internet or in any other way, is prohibited.



LittleDiode supplies new, hard to find or obsolete electronic components and semiconductors all over the world.

With over two million different components listed you are sure to find the part you need.

Feel free to visit us today at our online store:

LittleDiode.com

Looking forward to providing you with the best possible service.