



Dual N-Channel 20-V (D-S) MOSFET with Schottky Diode

PRODUCT SUMMARY			
	V _{DS} (V)	r _{DS(on)} (Ω)	I _D (A)
Channel-1	20	0.012 @ V _{GS} = 10 V	9.6
		0.0175 @ V _{GS} = 4.5 V	7.8
Channel-2		0.010 @ V _{GS} = 10 V	13.5
		0.0115 @ V _{GS} = 4.5 V	12.8

SCHOTTKY PRODUCT SUMMARY		
V _{DS} (V)	V _{SD} (V) Diode Forward Voltage	I _F (A)
20	0.53 V @ 3 A	2.0

FEATURES

- TrenchFET® Power MOSFET
- 100% R_g Tested

APPLICATIONS

- DC/DC Converters
 - Game Stations
 - Notebook PC Logic

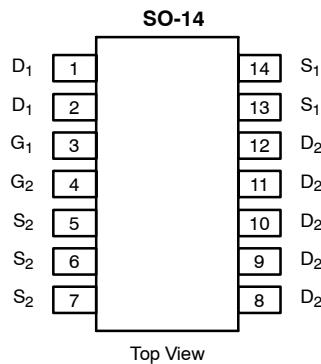

Ordering Information: Si4340DY
Si4340DY-T1 (with Tape and Reel)

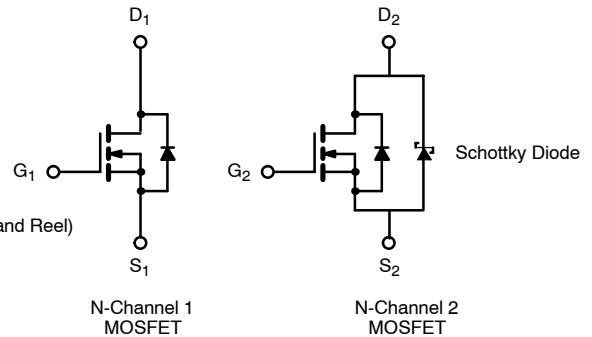

ABSOLUTE MAXIMUM RATINGS (T _A = 25 °C UNLESS OTHERWISE NOTED)							
Parameter	Symbol	Channel-1		Channel-2		Unit	
		10 secs	Steady State	10 secs	Steady State		
Drain-Source Voltage	V _{DS}	20				V	
Gate-Source Voltage	V _{GS}	± 20		± 16			
Continuous Drain Current (T _J = 150 °C) ^a	I _D	T _A = 25 °C	9.6	7.3	13.5	9.5	A
		T _A = 70 °C	7.7	5.8	10.8	7.5	
Pulsed Drain Current	I _{DM}	40		50		A	
Continuous Source Current (Diode Conduction) ^a	I _S	1.8	1.04	2.73	1.30		
Maximum Power Dissipation ^a	P _D	T _A = 25 °C	2.0	1.14	3.0	1.43	W
		T _A = 70 °C	1.28	0.73	1.9	0.91	
Operating Junction and Storage Temperature Range	T _J , T _{stg}	-55 to 150				°C	

THERMAL RESISTANCE RATINGS									
Parameter	Symbol	Channel-1		Channel-2		Schottky		Unit	
		Typ	Max	Typ	Max	Typ	Max		
Maximum Junction-to-Ambient ^a	R _{thJA}	t ≤ 10 sec	53	62.5	35	42	40	48	°C/W
		Steady-State	92	110	72	87	76	93	
Maximum Junction-to-Foot (Drain)	R _{thJF}	35	42	18	23	21	25		

Notes

a. Surface Mounted on 1" x 1" FR4 Board.

MOSFET SPECIFICATIONS ($T_J = 25^\circ\text{C}$ UNLESS OTHERWISE NOTED).							
Parameter	Symbol	Test Condition	Min	Typ ^a	Max	Unit	
Static							
Gate Threshold Voltage	$V_{GS(th)}$	$V_{DS} = V_{GS}, I_D = 250 \mu\text{A}$	Ch-1	0.8		2.00	V
			Ch-2	0.8		1.90	
Gate-Body Leakage	I_{GSS}	$V_{DS} = 0 \text{ V}, V_{GS} = \pm 20 \text{ V}$	Ch-1			100	nA
		$V_{DS} = 0 \text{ V}, V_{GS} = \pm 12 \text{ V}$	Ch-2			100	
Zero Gate Voltage Drain Current	I_{DSS}	$V_{DS} = 20 \text{ V}, V_{GS} = 0 \text{ V}$	Ch-1			1	μA
			Ch-2			100	
		$V_{DS} = 20 \text{ V}, V_{GS} = 0 \text{ V}, T_J = 85^\circ\text{C}$	Ch-1			15	
			Ch-2			4000	
On-State Drain Current ^b	$I_{D(on)}$	$V_{DS} = 5 \text{ V}, V_{GS} = 10 \text{ V}$	Ch-1	20			A
			Ch-2	30			
Drain-Source On-State Resistance ^b	$r_{DS(on)}$	$V_{GS} = 10 \text{ V}, I_D = 9.6 \text{ A}$	Ch-1		0.0095	0.012	Ω
		$V_{GS} = 10 \text{ V}, I_D = 13.5 \text{ A}$	Ch-2		0.007	0.010	
		$V_{GS} = 4.5 \text{ V}, I_D = 7.8 \text{ A}$	Ch-1		0.0135	0.0175	
		$V_{GS} = 4.5 \text{ V}, I_D = 12.8 \text{ A}$	Ch-2		0.0085	0.0115	
Forward Transconductance ^b	g_{fs}	$V_{DS} = 15 \text{ V}, I_D = 9.6 \text{ A}$	Ch-1		25		S
		$V_{DS} = 15 \text{ V}, I_D = 13.5 \text{ A}$	Ch-2		38		
Diode Forward Voltage ^b	V_{SD}	$I_S = 1.8 \text{ A}, V_{GS} = 0 \text{ V}$	Ch-1		0.74	1.1	V
		$I_S = 2.73 \text{ A}, V_{GS} = 0 \text{ V}$	Ch-2		0.485	0.53	
Dynamic^a							
Total Gate Charge	Q_g	Channel-1 $V_{DS} = 10 \text{ V}, V_{GS} = 4.5 \text{ V}, I_D = 9.6 \text{ A}$ Channel-2 $V_{DS} = 10 \text{ V}, V_{GS} = 4.5 \text{ V}, I_D = -13.5 \text{ A}$	Ch-1		10	15	nC
			Ch-2		17	25	
Gate-Source Charge	Q_{gs}		Ch-1		3.3		
			Ch-2		4.5		
Gate-Drain Charge	Q_{gd}		Ch-1		3.1		
			Ch-2		4.5		
Gate Resistance	R_g	$f = 1 \text{ MHz}$	Ch-1	0.45	0.9	1.35	Ω
			Ch-2	0.7	1.4	2.1	
Turn-On Delay Time	$t_{d(on)}$	Channel-1 $V_{DD} = 01 \text{ V}, R_L = 10 \Omega$ $I_D \cong 1 \text{ A}, V_{GEN} = 10 \text{ V}, R_G = 6 \Omega$ Channel-2 $V_{DD} = 01 \text{ V}, R_L = 15 \Omega$ $I_D \cong 1 \text{ A}, V_{GEN} = 10 \text{ V}, R_G = 6 \Omega$	Ch-1		15	25	ns
Rise Time	t_r		Ch-1		16	25	
			Ch-2		22	35	
Turn-Off Delay Time	$t_{d(off)}$		Ch-1		42	65	
			Ch-2		68	100	
Fall Time	t_f		Ch-1		16	25	
			Ch-2		19	30	
Source-Drain Reverse Recovery Time	t_{rr}		$I_F = 1.8 \text{ A}, di/dt = 100 \text{ A}/\mu\text{s}$	Ch-1		35	
		$I_F = 2.73 \text{ A}, di/dt = 100 \mu\text{A}/\mu\text{s}$	Ch-2		38	65	

Notes

- a. Guaranteed by design, not subject to production testing.
 b. Pulse test; pulse width $\leq 300 \mu\text{s}$, duty cycle $\leq 2\%$.

SCHOTTKY SPECIFICATIONS ($T_J = 25^\circ\text{C}$ UNLESS OTHERWISE NOTED)							
Parameter	Symbol	Test Condition	Min	Typ	Max	Unit	
Forward Voltage Drop	V_F	$I_F = 3 \text{ A}$		0.485	0.53	V	
		$I_F = 3 \text{ A}, T_J = 125^\circ\text{C}$		0.42	0.42		
Maximum Reverse Leakage Current	I_{rm}	$V_r = 20 \text{ V}$		0.008	0.100	mA	
		$V_r = 20 \text{ V}, T_J = 75^\circ\text{C}$		0.4	5		
		$V_r = -20 \text{ V}, T_J = 125^\circ\text{C}$		6.5	20		
Junction Capacitance	C_T	$V_r = 15 \text{ V}$		102		pF	



TYPICAL CHARACTERISTICS (25°C UNLESS NOTED)

CHANNEL-1

Output Characteristics

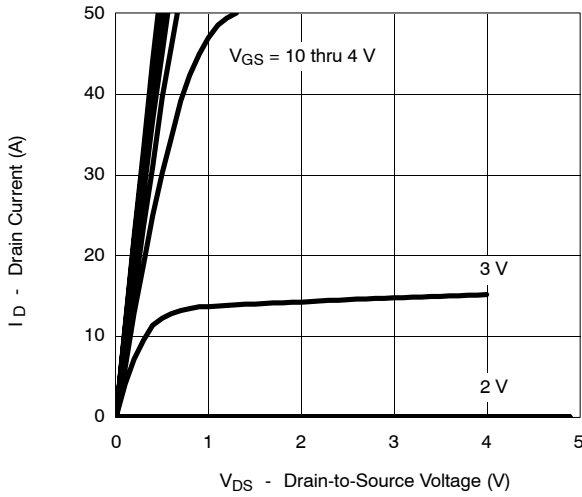

Transfer Characteristics

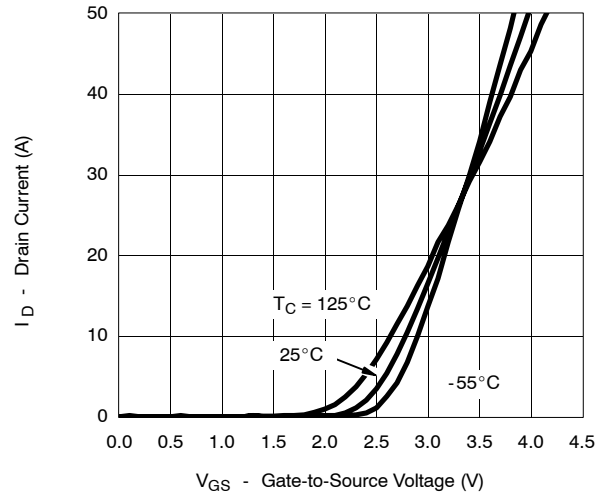

On-Resistance vs. Drain Current

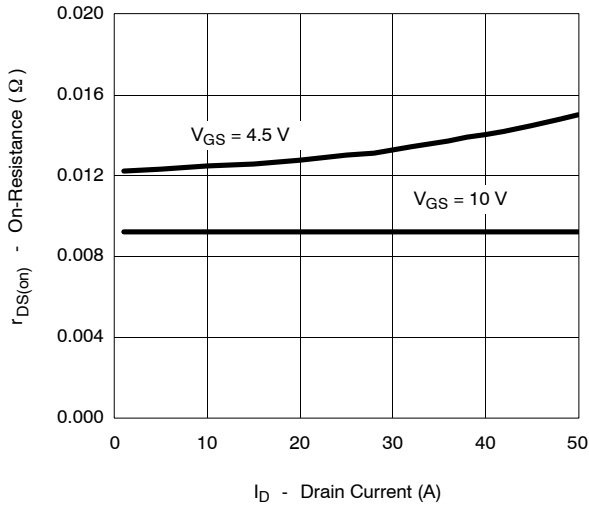

Capacitance

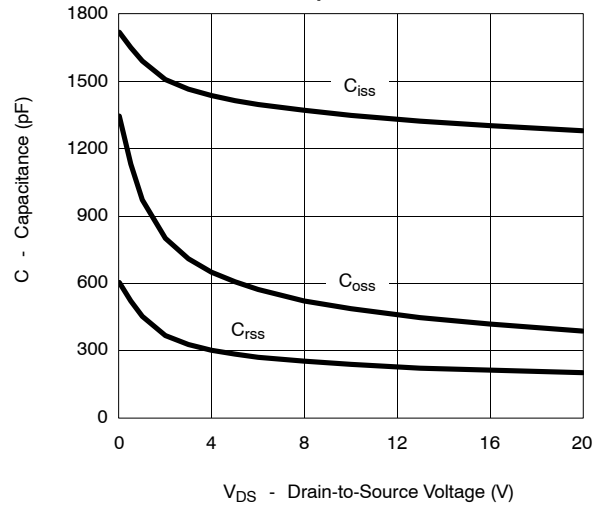

Gate Charge

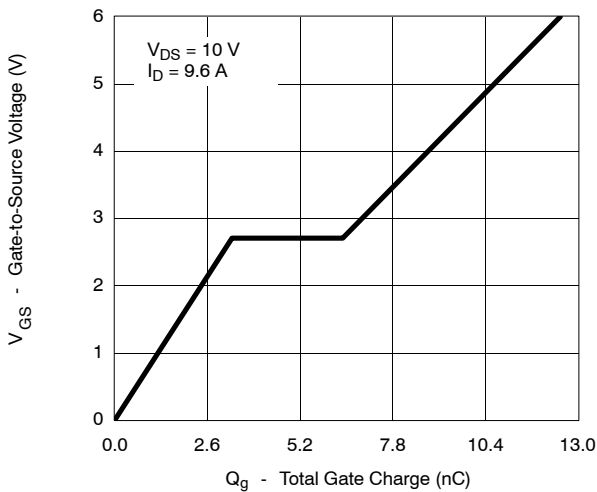

On-Resistance vs. Junction Temperature

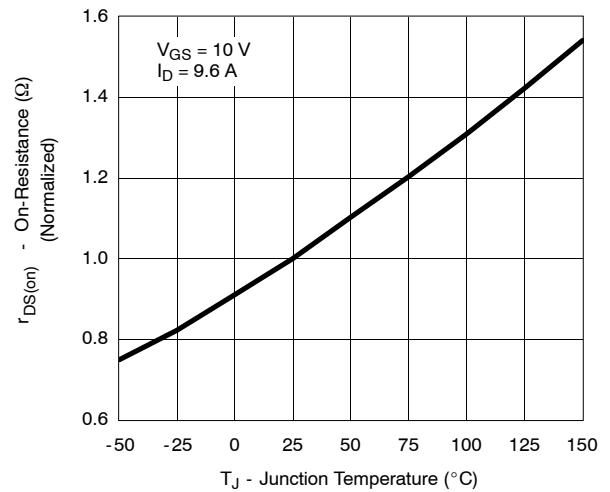

TYPICAL CHARACTERISTICS (25 °C UNLESS NOTED)

CHANNEL-1

Source-Drain Diode Forward Voltage

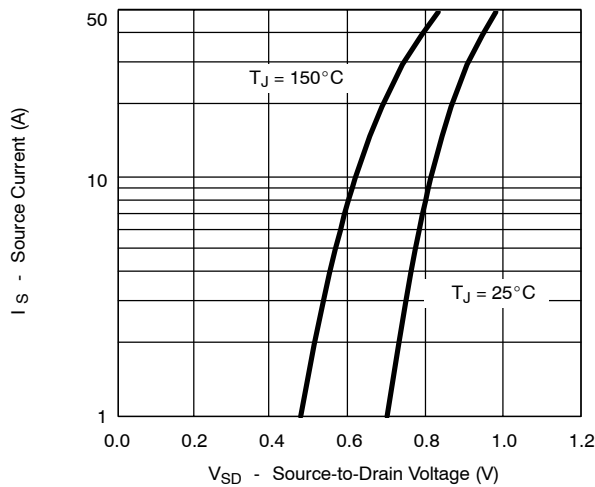

On-Resistance vs. Gate-to-Source Voltage

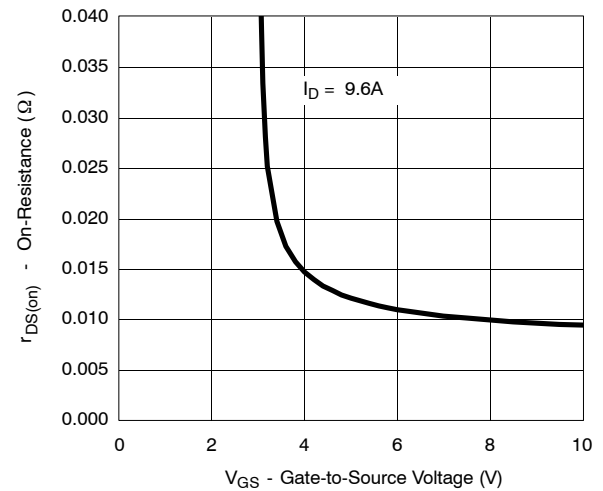

Threshold Voltage

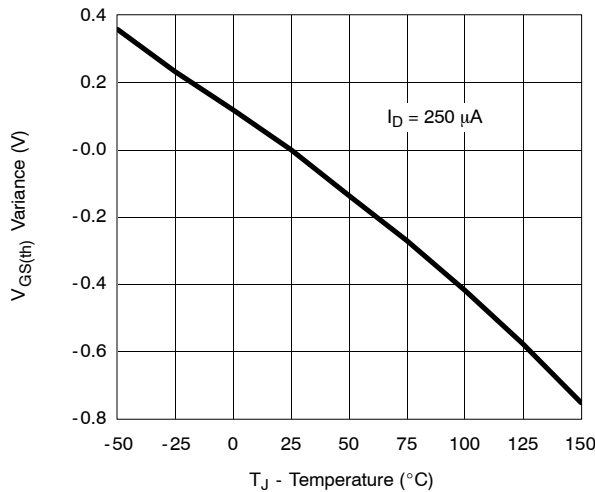

Single Pulse Power

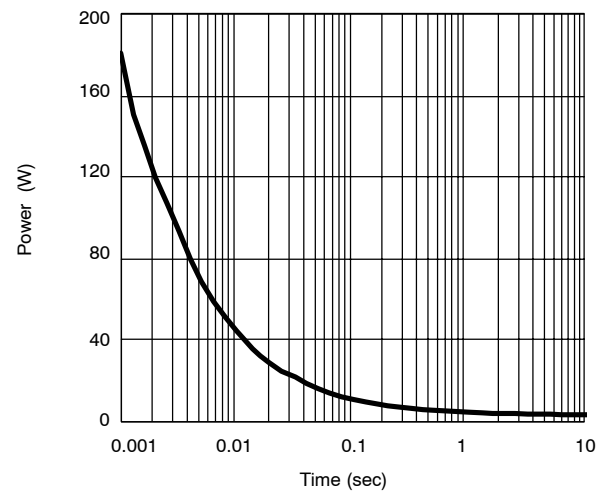

Safe Operating Area, Junction-to-Case

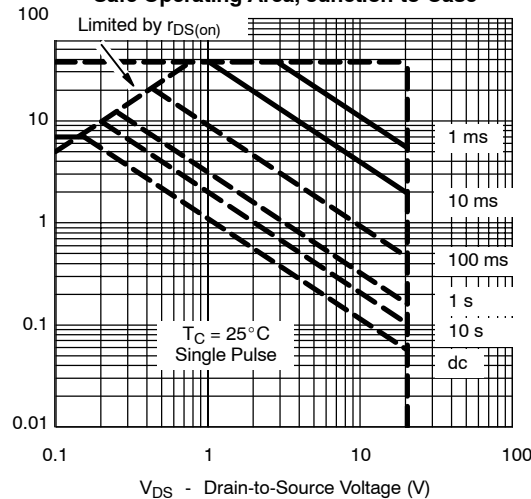



TYPICAL CHARACTERISTICS (25°C UNLESS NOTED) CHANNEL-1

Normalized Thermal Transient Impedance, Junction-to-Ambient

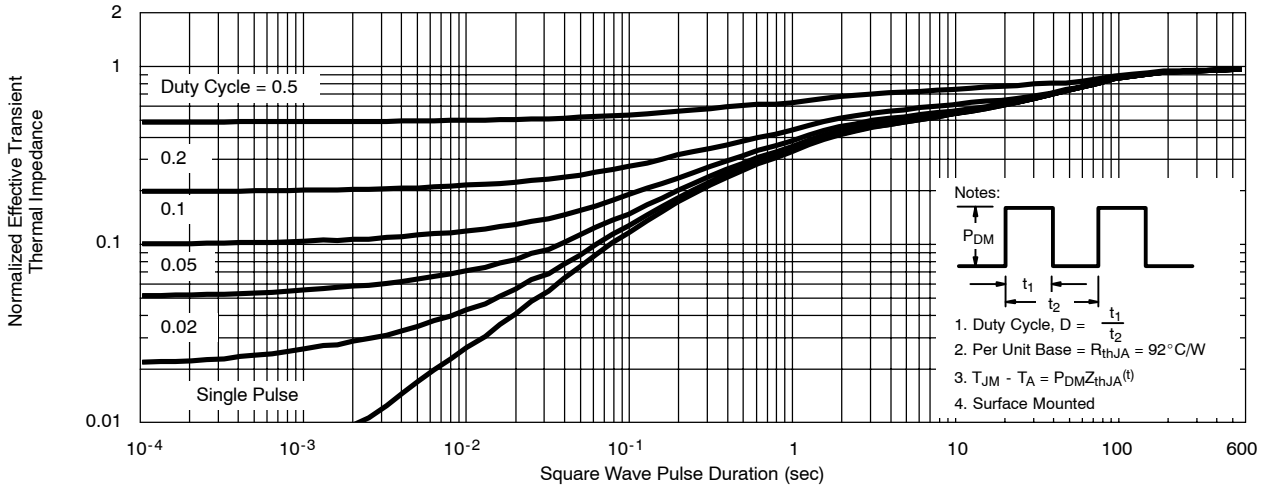

Normalized Thermal Transient Impedance, Junction-to-Foot

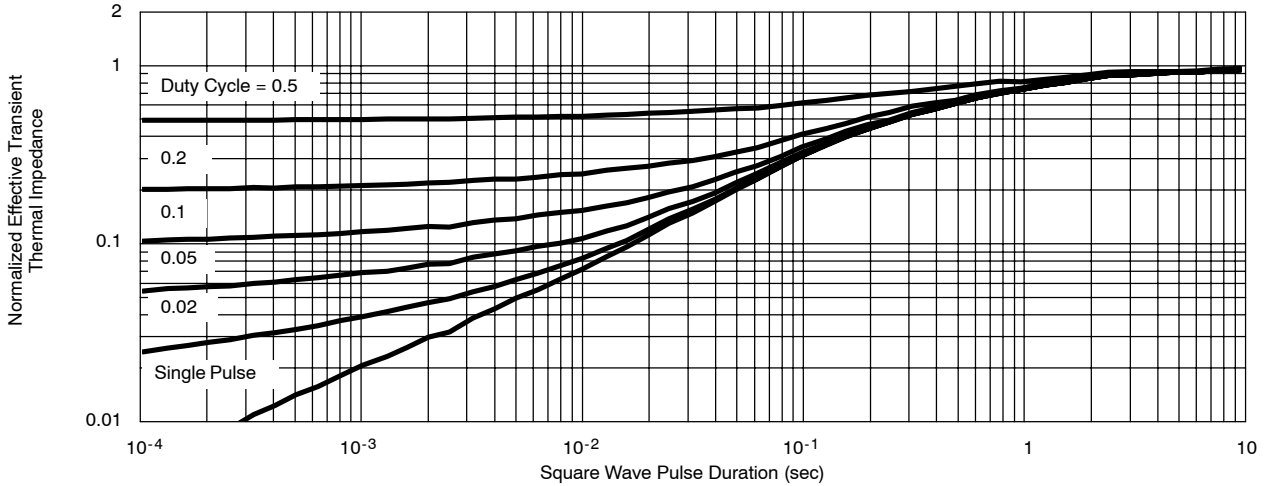



TYPICAL CHARACTERISTICS (25°C UNLESS NOTED)

CHANNEL-2

Output Characteristics

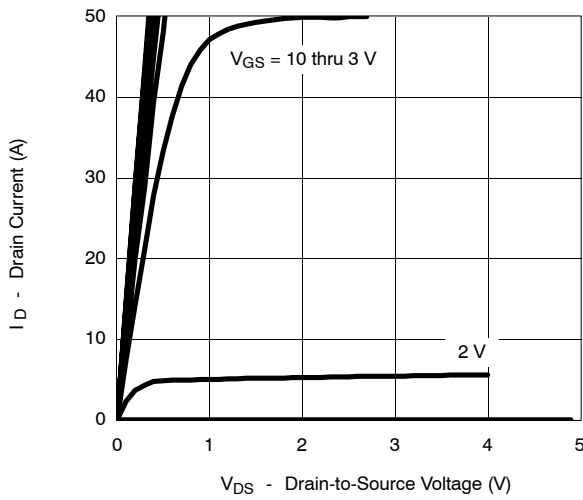

Transfer Characteristics

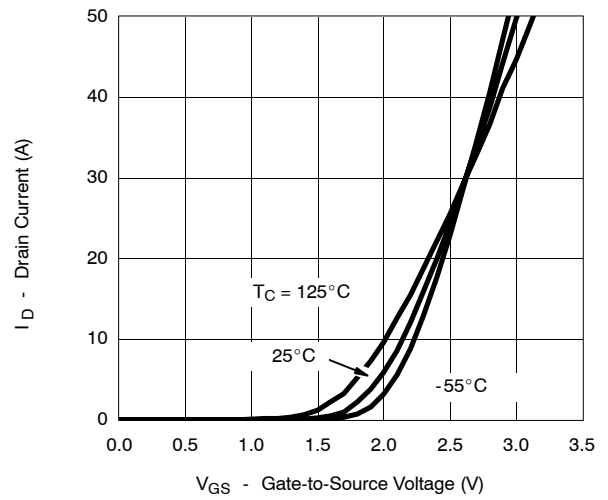

On-Resistance vs. Drain Current

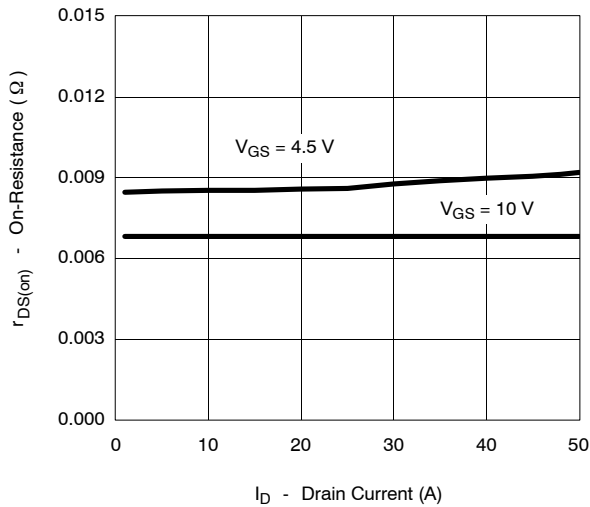

Capacitance

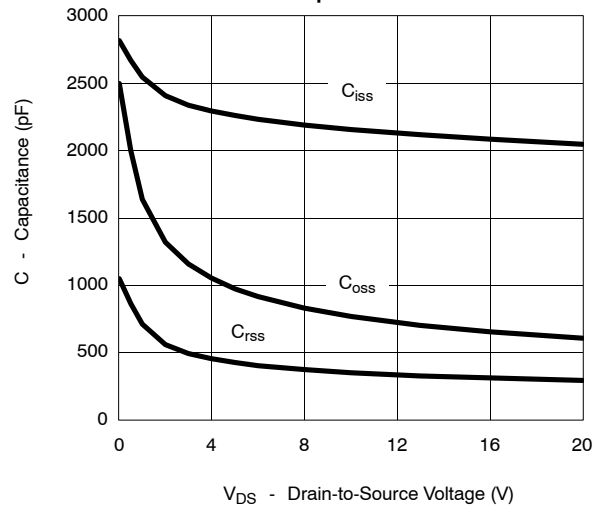

Gate Charge

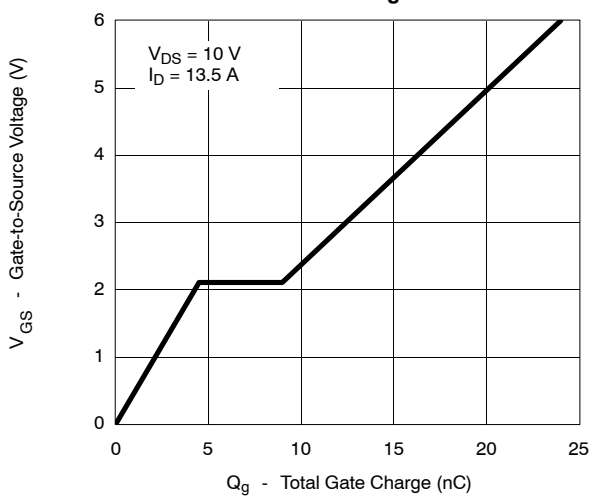

On-Resistance vs. Junction Temperature

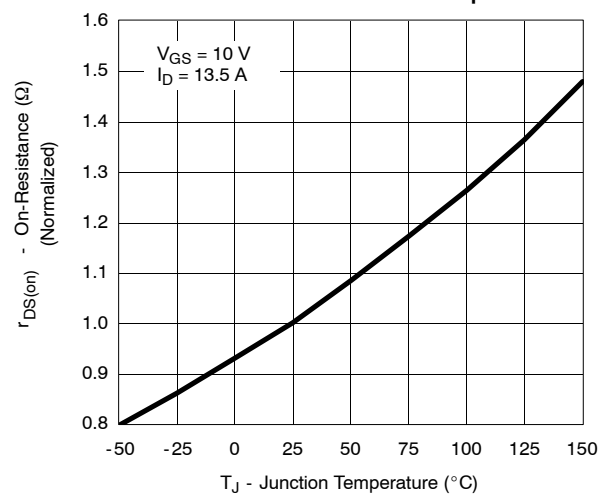



TYPICAL CHARACTERISTICS (25°C UNLESS NOTED) CHANNEL-2

Source-Drain Diode Forward Voltage

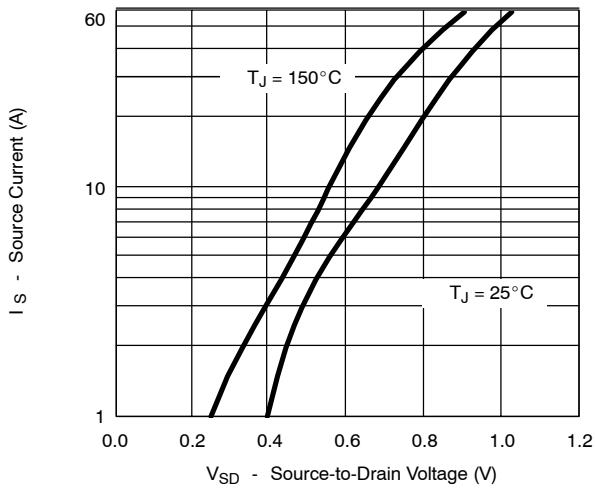

On-Resistance vs. Gate-to-Source Voltage

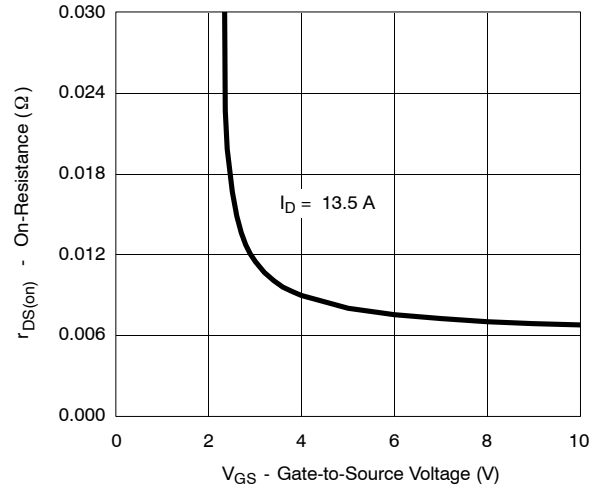

Reverse Current vs. Junction Temperature

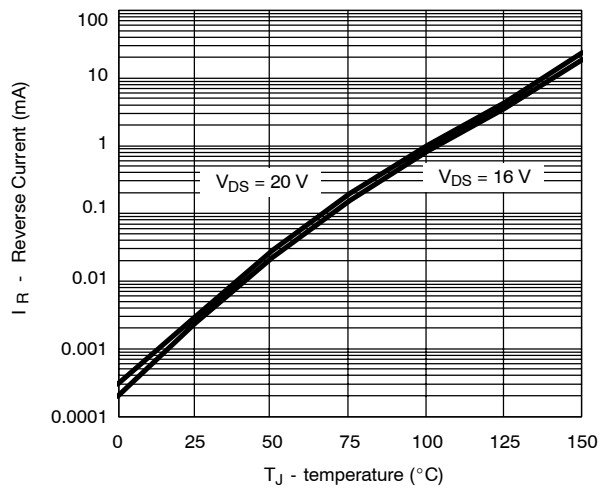

Single Pulse Power

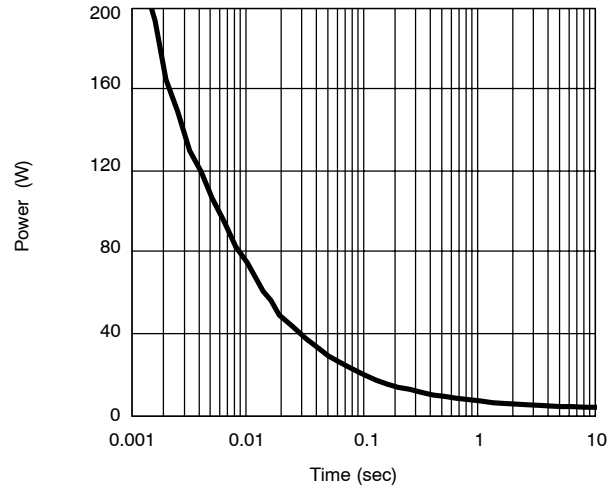

Safe Operating Area, Junction-to-Case

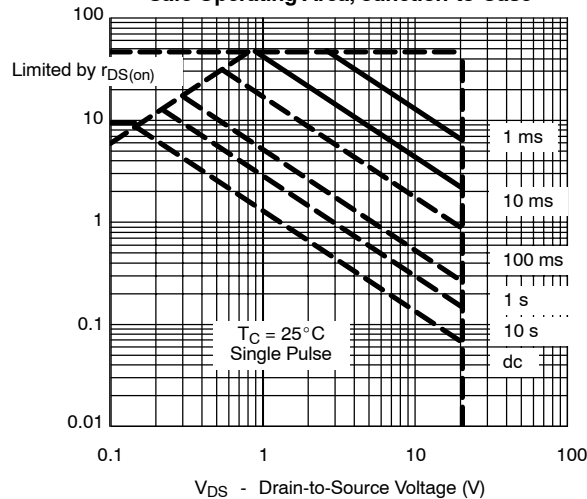

TYPICAL CHARACTERISTICS (25 °C UNLESS NOTED)

CHANNEL-2

Normalized Thermal Transient Impedance, Junction-to-Ambient

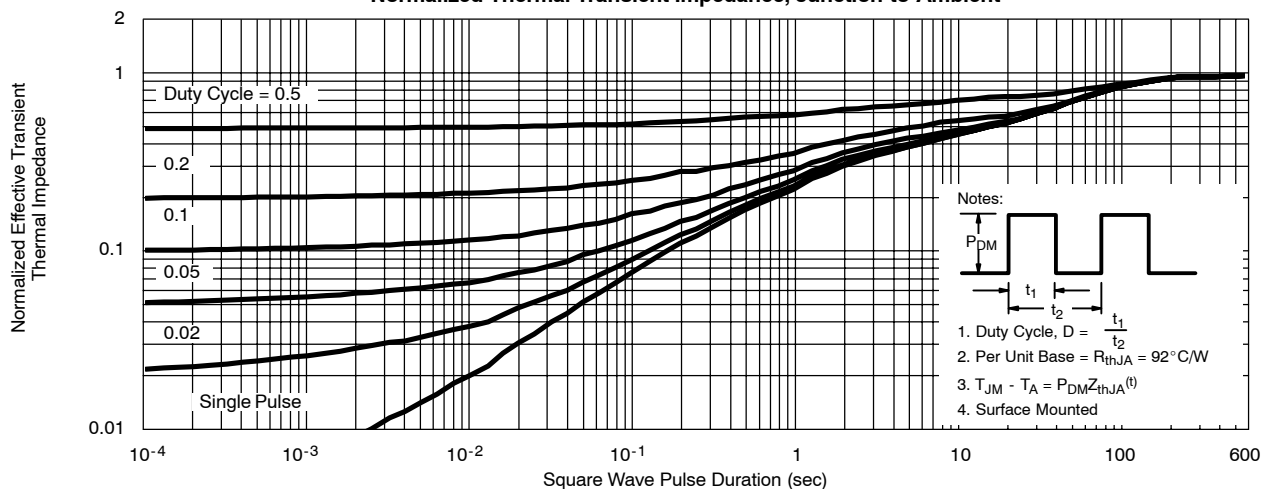

Normalized Thermal Transient Impedance, Junction-to-Foot

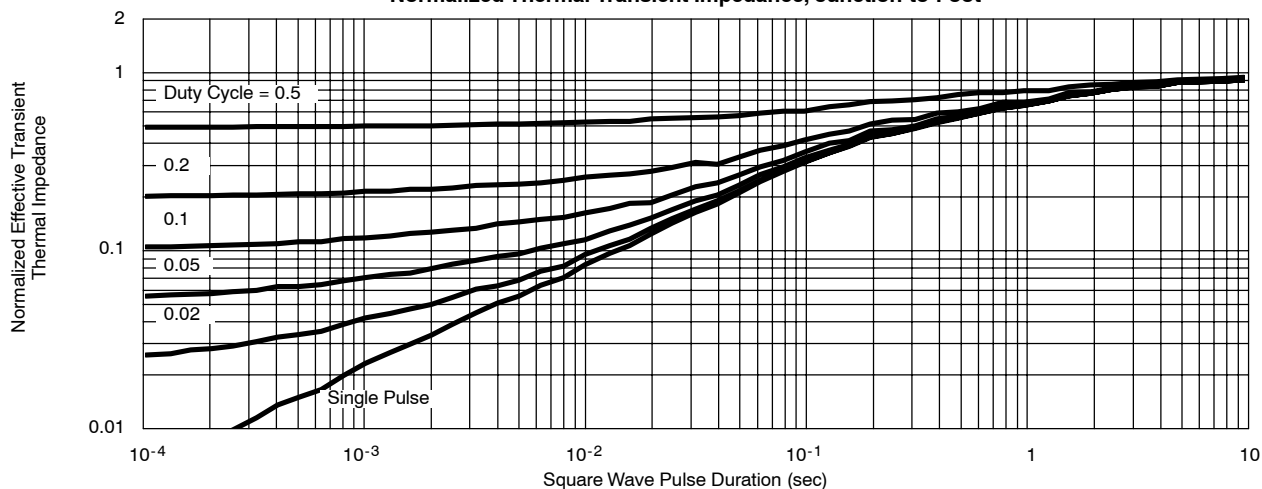

TYPICAL CHARACTERISTICS (25 °C UNLESS NOTED)

SCHOTTKY

Reverse Current vs. Junction Temperature

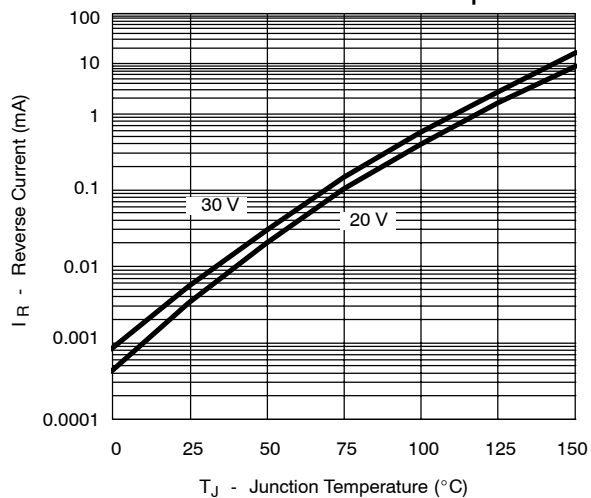

Forward Voltage Drop

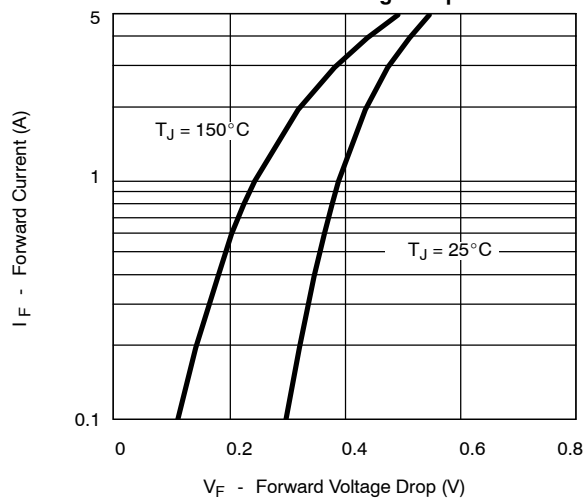



TYPICAL CHARACTERISTICS (25 °C UNLESS NOTED) **SCHOTTKY**

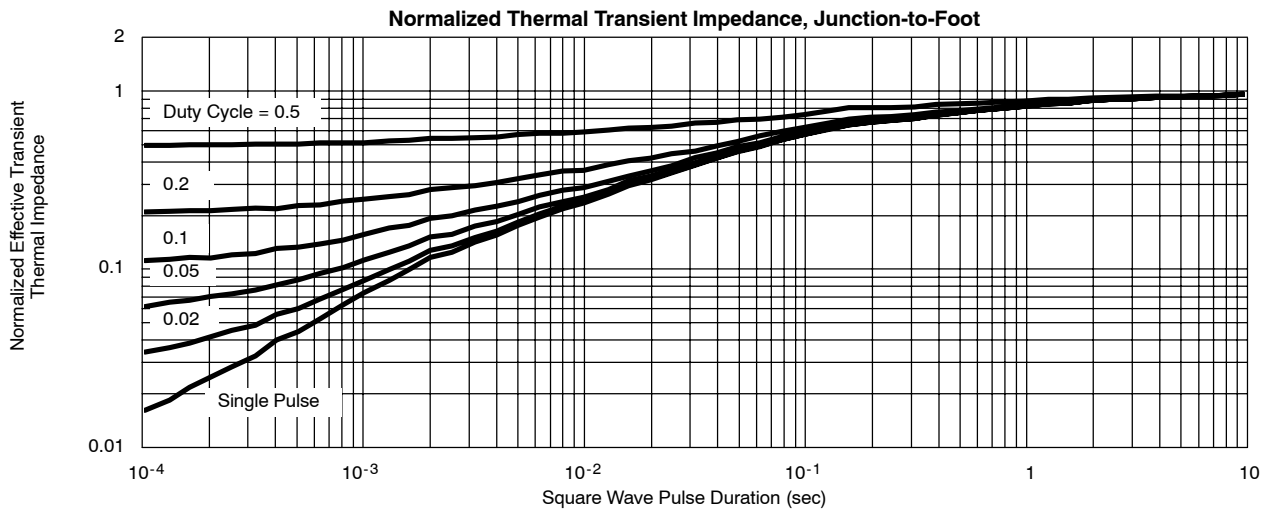
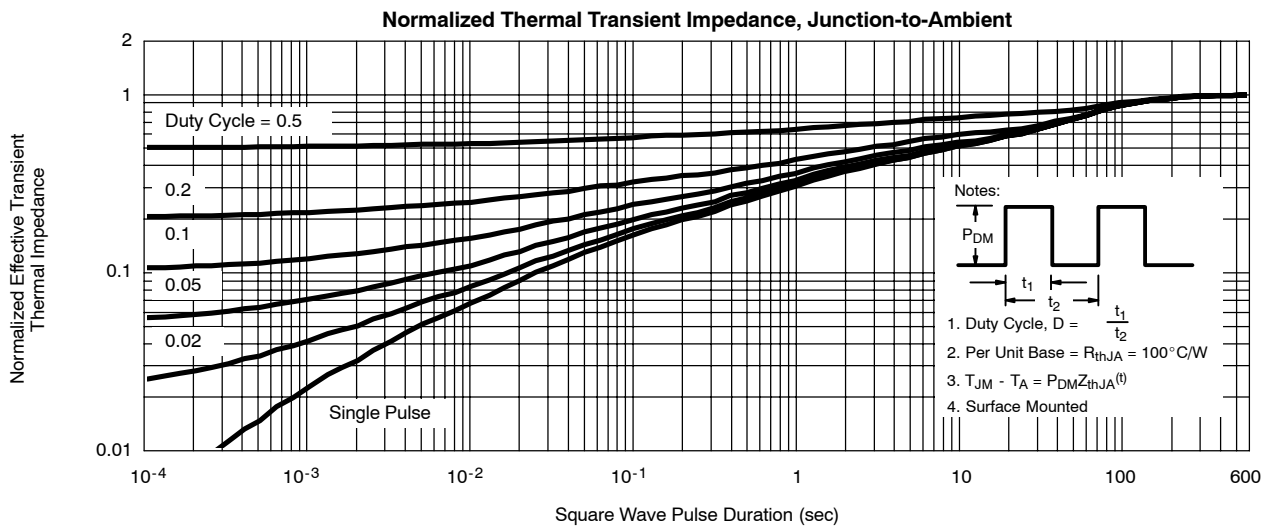
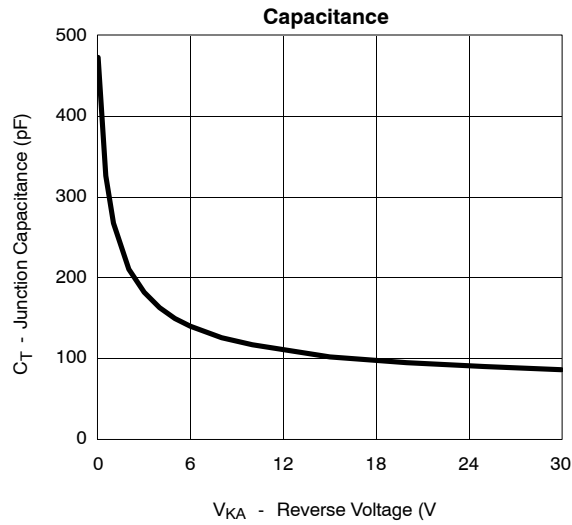



LittleDiode supplies new, hard to find or obsolete electronic components and semiconductors all over the world.

With over two million different components listed you are sure to find the part you need.

Feel free to visit us today at our online store:

LittleDiode.com

Looking forward to providing you with the best possible service.