

# AN7354SC

## Dolby\* B/C-type Noise Reduction

### ■ Overview

The AN7354SC is an IC for 2 ch. Dolby B/C-Type noise reduction process. It requires fewer external parts and incorporates the functions of line-output muting and level detection and the delay circuit.

### ■ Features

- Built-in spectral skewing circuit not requiring external parts
- Line-output muting circuit built-in
- PB input delay circuit built-in
- Built-in level detection circuit for automatic level adjustment and level meter
- ON/OFF of NR, B-/C-type, REC./PB, MPX and muting function, and Hi/Lo changeover of level detection gain, directly-controllable by microcomputer

\* Dolby symbols are the trademarks of Dolby Laboratory Licensing Corporation. The use of this products requires the approval of Dolby Laboratories Licensing Corporation in advance.

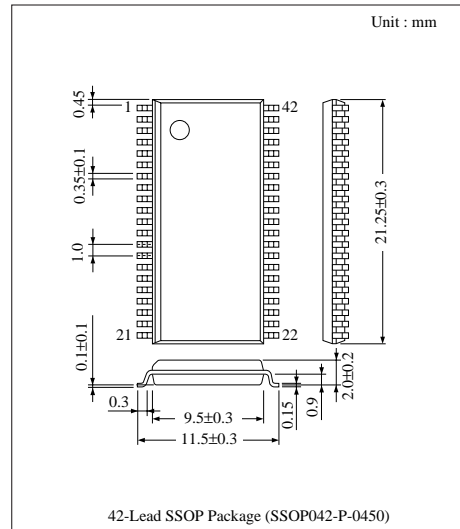

### ■ Block Diagram

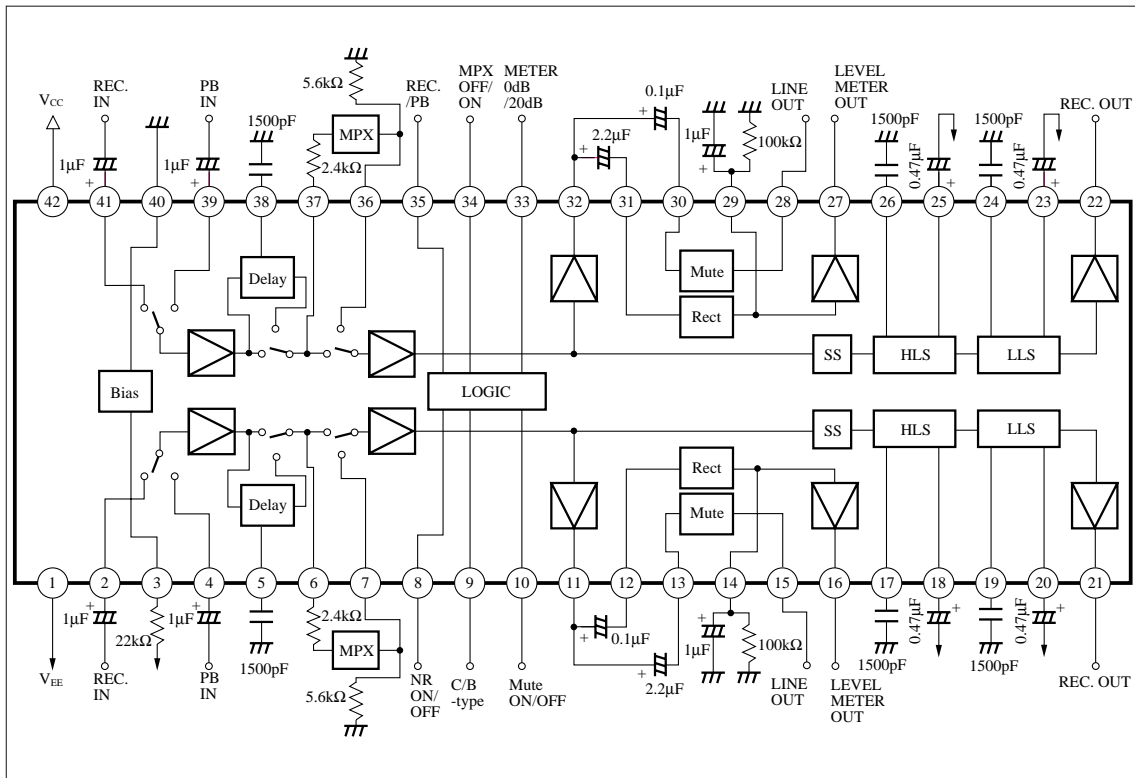

### ■ Absolute Maximum Ratings (Ta=25°C)

Parameter	Symbol	Rating	Unit
Supply Voltage	V <sub>CC</sub>	±6.7	V
Supply Current (Ta=75°C)	I <sub>CC</sub> (+)	+22	mA
	I <sub>CC</sub> (-)	-22	
Power Dissipation (Ta=75°C)	P <sub>D</sub>	295	mW
Operating Ambient Temperature	T <sub>opr</sub>	-20 ~ +75	°C
Storage Temperature	T <sub>stg</sub>	-55 ~ +125	°C

### ■ Recommended Operating Range (Ta=25°C)

Parameter	Symbol	Range
Operating Supply Voltage Range	V <sub>CC</sub>	±4.5V ~ ±6.5V

### ■ Electrical Characteristics (V<sub>CC</sub>=±6V, Ta=25°C ±2°C)

Parameter	Symbol	Condition	min.	typ.	max.	Unit
Total Circuit Current <sup>Note 1)</sup>	I <sub>CC</sub>	REC., OFF, No input signals	12	16	20	mA
REC. – IN to REC. – OUT I/O Gain <sup>Note 2)</sup>	G <sub>rin</sub>	REC., OFF, f = 1kHz REC. – OUT Level 388mV	17	19	21	dB
PB – IN to REC. – OUT I/O Gain <sup>Note 3)</sup>	G <sub>pin</sub>	PB, OFF, f = 1kHz REC. – OUT Level 388mV	22	24	26	dB
MPX ON/OFF Gain Difference	DG <sub>mpx</sub>	PB, OFF, f = 1kHz Gain difference from G <sub>pin</sub>	-1	0	1	dB
LINE – OUT Level	V <sub>lout</sub>	PB, OFF, f = 1kHz V <sub>in</sub> = 0dB	510	570	640	mVrms
B-type Encode Boost (1)	BR – 1	REC., B, f = 10kHz V <sub>in</sub> = -40dB	9.4	10.4	11.9	dB
B-type Encode Boost (2)	BR – 2	REC., B, f = 5kHz V <sub>in</sub> = -30dB	6.7	8.2	9.7	dB
B-type Encode Boost (3)	BR – 3	REC., B, f = 1kHz V <sub>in</sub> = -25dB	4.2	5.7	7.2	dB
B-type Encode Boost (4)	BR – 4	REC., B, f = 10kHz V <sub>in</sub> = 0dB	-1.1	0.4	1.9	dB
C-type Encode Boost (1)	CR – 1	REC., C, f = 1kHz V <sub>in</sub> = -60dB	18.1	19.6	21.6	dB
C-type Encode Boost (2)	CR – 2	REC., C, f = 5kHz V <sub>in</sub> = -40dB	11.5	13.5	15.5	dB
C-type Encode Boost (3)	CR – 3	REC., C, f = 300Hz V <sub>in</sub> = -30dB	8.7	10.7	12.7	dB
C-type Encode Boost (4)	CR – 4	REC., C, f = 5kHz V <sub>in</sub> = -25dB	3.5	5.5	7.5	dB
C-type Encode Boost (5)	CR – 5	REC., C, f = 15kHz V <sub>in</sub> = 0dB	-8.3	-6.3	-4.3	dB
Signal Handling	V <sub>Omax</sub>	REC., OFF, f = 1kHz V <sub>CC</sub> = ±4.5V THD = 1%	12	13	—	dB
Total Harmonics Distortion – off	THDO	REC., OFF, f = 1kHz V <sub>in</sub> = 0dB	—	0.02	0.15	%
Total Harmonics Distortion – C	THDC	REC., C, f = 1kHz V <sub>in</sub> = 0dB	—	0.13	0.3	%
Signal to Noise Ratio	S/N	REC., C, R <sub>g</sub> = 5.1kΩ CCIR/ARM Weighted	60.0	62.5	—	dB
Mode Switch Offset	V <sub>ofs</sub> – R	REC., OFF, → C switch, REC. – OUT potential fluctuation	-70	0	70	mV

Note 1) REC., OFF in the condition description, expresses that MODE is REC. and NR is OFF. The same for the following.

Note 2) Obtain the input voltage of REC. – IN when the output voltage of REC. – OUT becomes 388mVrms. For this input voltage, the reference level in REC. is assumed 0dB.

Note 3) Obtain the input voltage of PB. – IN when the output voltage of REC. – OUT becomes 388mVrms. For this input voltage, the reference level in PB is assumed 0dB.

**■ Electrical Characteristics (Cont.)** ( $V_{CC} = \pm 6V$ ,  $T_a = 25^\circ C \pm 2^\circ C$ )

Parameter	Symbol	Condition	min.	typ.	max.	Unit
Channel Balance	CB	Gain difference between channels, $G_{in}$ and $G_{pin}$	-1	0	1	dB
Total Harmonics Distortion Line Out	THDP	PB, OFF, $f = 1kHz$ $V_{in} = 0dB$ , LINE - OUT	—	0.02	0.15	%
Line Mute Attenuation	$G_{mut}$	PB, OFF, Mute ON $f = 1kHz$ , $V_{in} = 0dB$	—	-85	-75	dB
Line Mute Offset	Vofs - M	Mute OFF → ON switching, LINE - OUT potential fluctuation	-20	0	20	mV
Level Meter Output (1) <sup>Note 4)</sup>	VDC (1)	PB, OFF, LMG Normal $f = 1kHz$ , $V_{in} = -3dB$	0.9	1.0	1.1	V
Level Meter Output (2)	VDC (2)	PB, OFF, LMG Normal $f = 1kHz$ , $V_{in} = +9dB$	3.6	4.0	4.4	V
Level Meter Output (3)	VDC (3)	PB, OFF, LMG High $f = 1kHz$ , $V_{in} = -18dB$	0.9	1.0	1.1	V
Level Meter Output Offset	Vofs - L	PB, OFF, LMG Normal No Input	-15	0	15	mV
Delay Output (1)	VPS (1)	$V_{in} = -0.2V$ S30 → C PB MPX off Piny and Pin#7 DC Potential	2	3	4	V
Delay Output (2)	VPS (2)	$V_{in} = +0.2V$ S30 → C PB MPX off Difference from VPS (1)	4	6	8	V
Delay Output (3)	VPS (3)	$V_{in} = -0.2V$ S30 → B PB MPX off Piny and Pin#7 DC Potential	-0.1	0	0.1	V
Delay Output (4)	VPS (4)	$V_{in} = +0.2V$ S30 → B PB MPX off Difference from VPS (3)	-0.2	0	0.2	V
Delay Output (5)	VPS (5)	$V_{in} = -0.2V$ S30 → A PB MPX off Piny and Pin#7 DC Potential	-4	-3	-2	V
Delay Output (6)	VPS (6)	$V_{in} = +0.2V$ S30 → A PB MPX off Difference from VPS (5)	4	6	8	V

Note 4) LMG in the condition description is an abbreviation of Level Meter Gain.

### ■ Electrical Characteristics (Ta=25°C±2°C) [Design Reference Values]

The following characteristic values are reference values for design but not guaranteed values.

Parameter	Symbol	Condition	min.	typ.	max.	Unit
Decreased Voltage Mute (1)	$V_{mut(1)}$	PB, OFF, Mute OFF, f=1kHz, $V_{in} = 0dB$ Voltage between Pins1 and 42 when mute functions	4.4	6.4	8.4	V
Crosstalk, REC.- IN to LINE- OUT	CT- RP	PB, OFF, f= 1kHz $V_{in} = 0dB$ (At REC)	—	-80	-70	dB
Crosstalk, PB- IN to REC.- OUT	CT- PR	PB, OFF, f= 1kHz $V_{in} = 0dB$ (At PB)	—	-80	-70	dB
Crosstalk, Cannel to Cannel	CT- CC	PB, OFF, f= 1kHz $V_{in} = 0dB$	—	-80	-70	dB
PB/REC. Control Voltage PB	$V_{cPB}$	Pin35 applied DC voltage when PB, MPX are OFF	+2.5	—	+6	V
PB/REC. Control Voltage REC.	$V_{cREC.}$	Pin35 applied DC voltage when PB, MPX are ON	-1.5	—	+1.5	V
MPX Control Voltage ON	$V_{cMon}$	Pin34 applied DC voltage when PB, MPX are ON	-1.5	—	+1.5	V
MPX Control Voltage OFF	$V_{cMoff}$	Pin34 applied DC voltage when PB, MPX are OFF	+2.5	—	+6	V
Meter Control Voltage Normal	$V_{cMnor}$	Pin33 applied DC voltage when Meter becomes Normal	+2.5	—	+6	V
Meter Control Voltage Hi	$V_{cMhi}$	Pin33 applied DC voltage when Meter becomes Hi	-1.5	—	+1.5	V
NR Control Voltage ON	$V_{cON}$	Pin8 applied DC voltage when NR is ON	+2.5	—	+6	V
NR Control Voltage OFF	$V_{cOFF}$	Pin8 applied DC voltage when NR is OFF	-1.5	—	+1.5	V
B/C Control Voltage C	$V_{cC}$	Pin9 applied DC voltage for C-type NR	+2.5	—	+6	V
B/C Control Voltage B	$V_{cB}$	Pin9 applied DC voltage for B-type NR	-1.5	—	+1.5	V
Mute Control Voltage ON	$V_{cMUon}$	Pin10 applied DC voltage when Mute is ON	+2.5	—	+6	V
Mute Control Voltage OFF	$V_{cMUof}$	Pin10 applied DC voltage when Mute is OFF	-1.5	—	+1.5	V
REC.- IN Input Resistance	$R_{in} - RI$		56.4	64	75.6	k $\Omega$
PB - IN Input Resistance	$R_{in} - PI$		28.05	33	37.95	k $\Omega$

■ Characteristics Curve

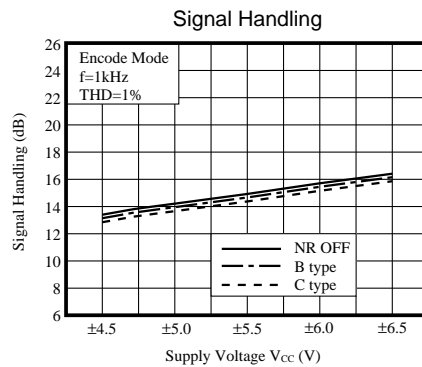
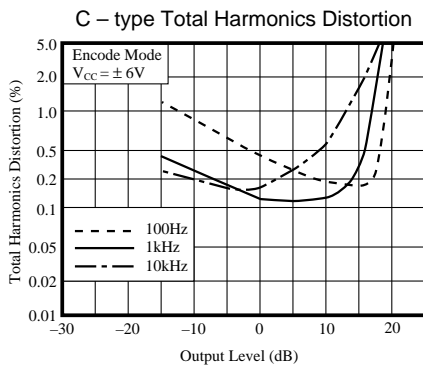
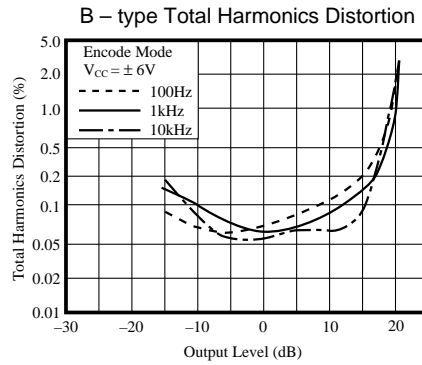
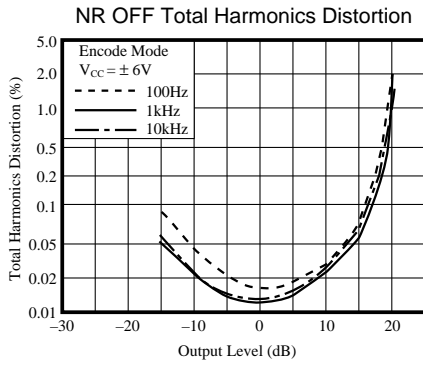
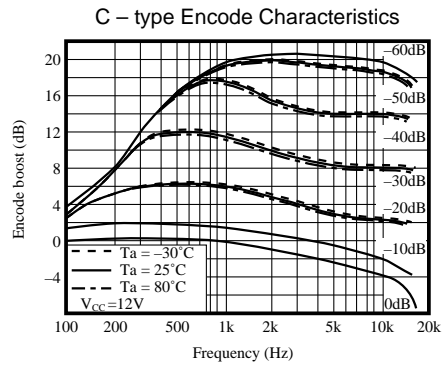
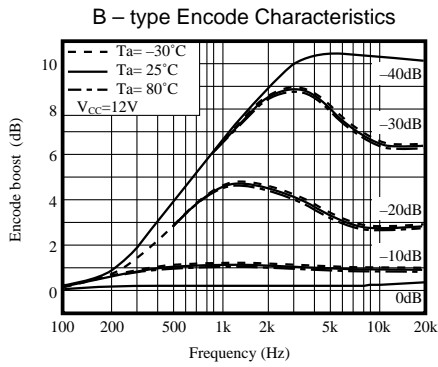
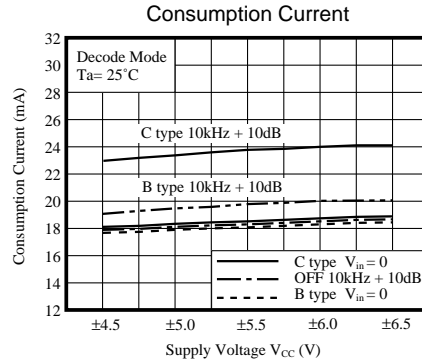
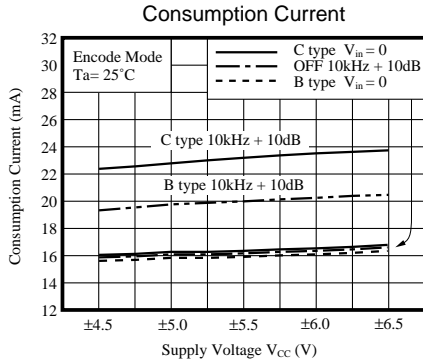

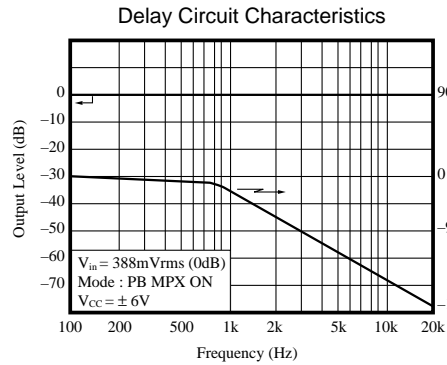
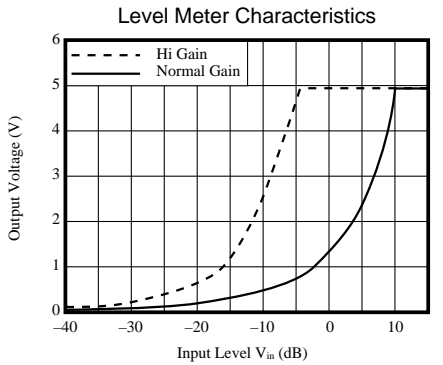
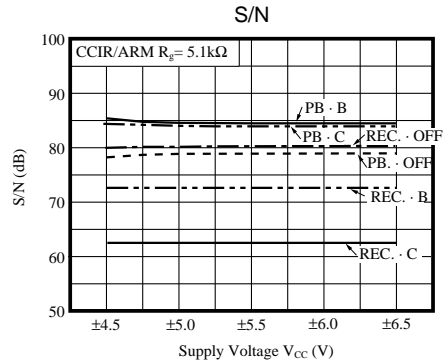
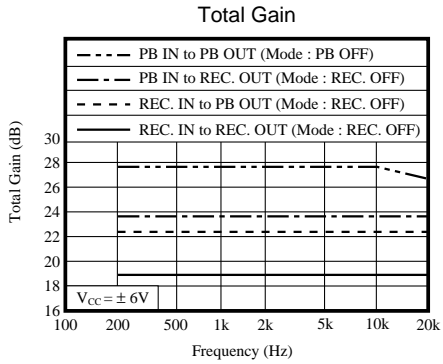
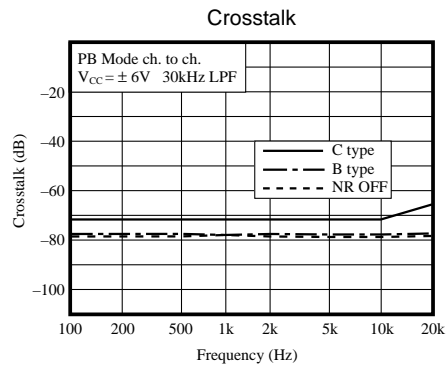
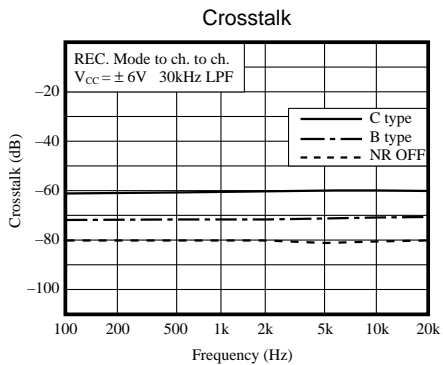
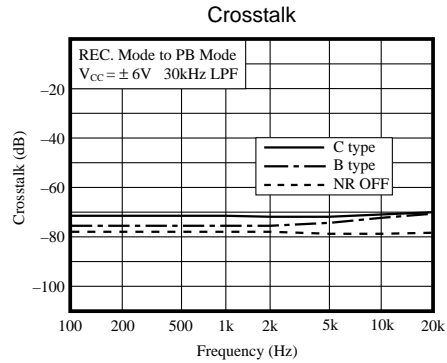
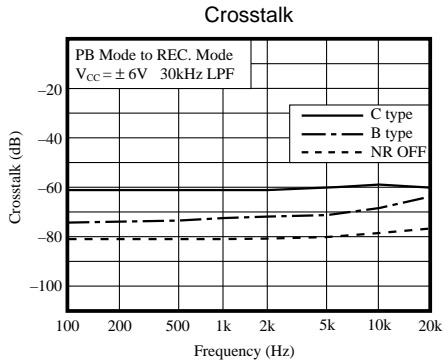

■ Pin Description

Pin No.	Pin Name	Input Impedance Pin Voltage	Pin Description	Equivalent Circuit
1	V <sub>EE</sub>	-6V	Supply voltage (-)	_____
42	V <sub>CC</sub>	6V	Supply voltage (+)	_____
40	GND	0V	Ground neutral GND	_____
33	METER Nor/Hi	100kΩ 3.1V	Level meter Normal/Hi changeover switch pin	
34	MPX OFF/ON	100kΩ 3.1V	MPX OFF/ON changeover switch pin	
35	PB/REC.	100kΩ 3.1V	PB -Mode/ REC.-Mode changeover switch pin	

■ Pin Description (Cont.)

Pin No.	Pin Name	Input Impedance Pin Voltage	Pin Description	Equivalent Circuit
2 41	REC. IN	66kΩ neutral GND	Record input pin	
3	I <sub>REF</sub>	7∞ -5V	Internal resistor error calibration pin	
4 39	PB - IN	33kΩ neutral GND	Playback input pin	
5 38	Delay	22kΩ neutral GND	Delay circuit control pin	
6 37	MPX OUT	70Ω -45mV	MPX drive amp. output pin	

■ Pin Description (Cont.)

Pin No.	Pin Name	Input Impedance Pin Voltage	Pin Description	Equivalent Circuit
7 36	MPX IN	500Ω -30mV	MPX gain aux. amp. input pin	
8	NR ON/OFF	100kΩ3.1V	NR ON/OFF changeover switch pin	
9	C/B-type	100kΩ3.1V	C/B type changeover switch pin	
10	Mute ON/OFF	100kΩ 3.1V	Mute ON/OFF changeover switch pin	
11 32	LINE OUT	43Ω neutral GND	Playback output pin	

■ Pin Description (Cont.)

Pin No.	Pin Name	Input Impedance Pin Voltage	Pin Description	Equivalent Circuit
12 31	METER IN	20kΩ neutral GND	Level meter input pin	
13 30	MUTE - IN	20kΩ neutral GND	Mute input pin	
14 29	LEVEL	1kΩ neutral GND	Level meter control pin	
15 28	LINE MUTE OUT	63kΩ neutral GND	Playback mute output pin	
16 27	METER OUT	1kΩ neutral GND	Level meter output pin	

■ Pin Description (Cont.)

Pin No.	Pin Name	Input Impedance Pin Voltage	Pin Description	Equivalent Circuit
17 26	VCR H	Neutral GND	HLS side chain control resistor pin	
18 25	RECT H	-5.45V	HLS control signal smoothing pin	
19 24	VCR L	Neutral GND	LLS side chain control resistor pin	
20 23	RECT-L	-5.45V	LLS control signal smoothing pin	
21 22	REC. OUT	56Ω neutral GND	Record output pin	

**■ Precautions on Product Handling and Mounting**

The AN7354SC Package is dry-sealed, because thermal stress at solder mounting may adversely affect the product reliability due to the moisture absorption in the resin.

Take into consideration the following instructions for its use :

1. After unpacking the dry sealing package, in order to reduce absorption of the resin, store the product under temperature of 30°C or lower and RH65% or less, and perform its mounting within 5 days following the unpacking, except when only lead section is heated by such as hand soldering. In addition, after unpacking, put the remainder back into the laminate bag and seal the bag with tapes or similars. Unless the silica gel in the bag discolors (blue to pink), its quality is guaranteed within 10 days.
2. If the product is stored under the conditions more than the above, pre-bake it (for 6 hours or more under 125°C, or for 48 hours more under 70°C) before mounting.
3. About soldering method
  - (1) Solder dip method

Solder dip must be performed under as low temperature as possible not exceeding 260°C and for as short time as possible not exceeding 5s.
  - (2) Reflow method

((Remarks)) 1 Peak temperature : 230°C or lower  
2 Peak time : 10s or shorter  
3 Do not sharply rise the temperature from pre-heat temperature (150°C or lower) to peak temperature (230°C).  
4 Reflow process must be performed only once.
  - (3) Hand soldering method

When only leads are simultaneously heated, soldering must be performed under as low temperature as possible not exceeding 300°C and for as short time as possible not exceeding 20s.
  - (4) For any soldering method, do not use the chlorine flux. If the chlorine flux is used, residual chlorine may adversely affect the product reliability.

Thoroughly clean the IC after mounting. Any flux remaining after mounting results in lead corrosion, degrading the product reliability. In addition, if supersonic waves are used for cleaning, particular care must be taken, because resonance may occur depending on the size of IC and printed board.

## Request for your special attention and precautions in using the technical information and semiconductors described in this material

- (1) An export permit needs to be obtained from the competent authorities of the Japanese Government if any of the products or technologies described in this material and controlled under the "Foreign Exchange and Foreign Trade Law" is to be exported or taken out of Japan.
- (2) The technical information described in this material is limited to showing representative characteristics and applied circuit examples of the products. It does not constitute the warranting of industrial property, the granting of relative rights, or the granting of any license.
- (3) The products described in this material are intended to be used for standard applications or general electronic equipment (such as office equipment, communications equipment, measuring instruments and household appliances).  
Consult our sales staff in advance for information on the following applications:
  - Special applications (such as for airplanes, aerospace, automobiles, traffic control equipment, combustion equipment, life support systems and safety devices) in which exceptional quality and reliability are required, or if the failure or malfunction of the products may directly jeopardize life or harm the human body.
  - Any applications other than the standard applications intended.
- (4) The products and product specifications described in this material are subject to change without notice for reasons of modification and/or improvement. At the final stage of your design, purchasing, or use of the products, therefore, ask for the most up-to-date Product Standards in advance to make sure that the latest specifications satisfy your requirements.
- (5) When designing your equipment, comply with the guaranteed values, in particular those of maximum rating, the range of operating power supply voltage and heat radiation characteristics. Otherwise, we will not be liable for any defect which may arise later in your equipment.  
Even when the products are used within the guaranteed values, redundant design is recommended, so that such equipment may not violate relevant laws or regulations because of the function of our products.
- (6) When using products for which dry packing is required, observe the conditions (including shelf life and after-unpacking standby time) agreed upon when specification sheets are individually exchanged.
- (7) No part of this material may be reprinted or reproduced by any means without written permission from our company.

## Please read the following notes before using the datasheets

- A. These materials are intended as a reference to assist customers with the selection of Panasonic semiconductor products best suited to their applications.  
Due to modification or other reasons, any information contained in this material, such as available product types, technical data, and so on, is subject to change without notice.  
Customers are advised to contact our semiconductor sales office and obtain the latest information before starting precise technical research and/or purchasing activities.
- B. Panasonic is endeavoring to continually improve the quality and reliability of these materials but there is always the possibility that further rectifications will be required in the future. Therefore, Panasonic will not assume any liability for any damages arising from any errors etc. that may appear in this material.
- C. These materials are solely intended for a customer's individual use.  
Therefore, without the prior written approval of Panasonic, any other use such as reproducing, selling, or distributing this material to a third party, via the Internet or in any other way, is prohibited.



LittleDiode supplies new, hard to find or obsolete electronic components and semiconductors all over the world.

With over two million different components listed you are sure to find the part you need.

Feel free to visit us today at our online store:

[LittleDiode.com](http://LittleDiode.com)

Looking forward to providing you with the best possible service.