

AN7337NS

7-element graphic equalizer IC for Hi-Fi audio equipment

■ Overview

The AN7337NS is a graphic equalizer IC for high performance Hi-Fi audio equipment developed for deck. It incorporates an output buffer circuit and 7 resonance buffer circuits, and can set resonance frequency by external capacitor.

■ Features

- Low distortion (max.: 0.03%)
- Low noise voltage (input short circuit: max.: 30 $\mu\text{V[rms]}$)
- High output voltage (typ. 9.5 V)

■ Applications

- Mini-component stereo, system component stereo

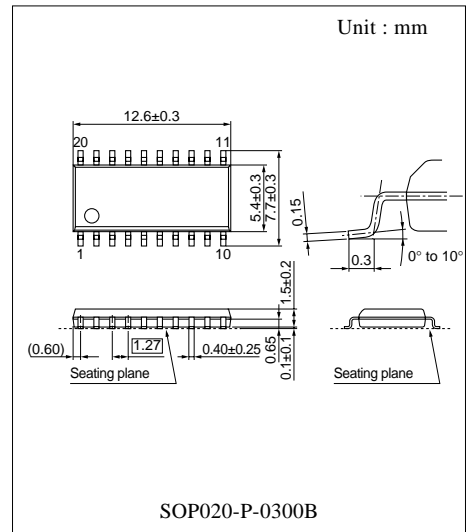

■ Block Diagram

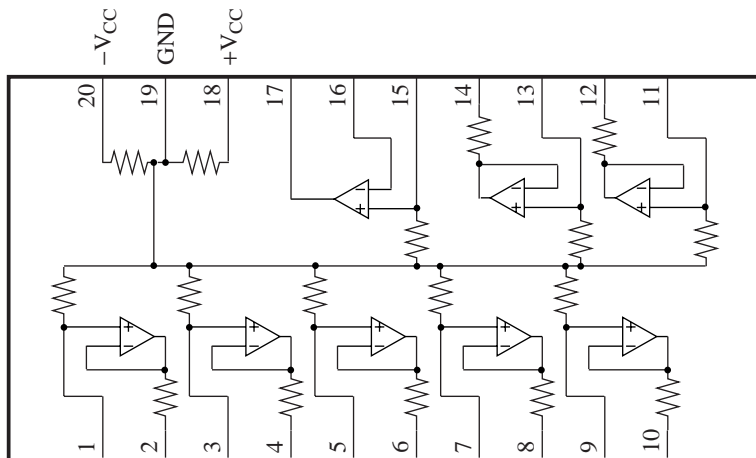

■ Pin Descriptions

Pin No.	Description	Pin No.	Description
1	In 1	11	In 6
2	NF 1	12	NF 6
3	In 2	13	In 7
4	NF 2	14	NF 7
5	In 3	15	Non-inverting input
6	NF 3	16	Inverting input
7	In 4	17	Output
8	NF 4	18	+ V _{CC}
9	In 5	19	GND
10	NF 5	20	- V _{CC}

■ Absolute Maximum Ratings

Parameter	Symbol	Rating	Unit
Supply voltage	V _{CC}	± 18	V
Supply current	I _{CC}	± 50	mA
Power dissipation *2	P _D	230	mW
Operating ambient temperature *1	T _{opr}	-20 to +75	°C
Storage temperature *1	T _{stg}	-55 to +125	°C

Note) *1 : All items are at T_a = 25°C, except for the operating ambient temperature and storage temperature.

*2 : Referring to "■ Technical Information" for power dissipation at T_a = 75°C, use the circuit under the conditions of the V_{CC} × I_{CC} is not exceeding the P_Dmax.

■ Recommended Operating Range

Parameter	Symbol	Range	Unit
Supply voltage	V _{CC}	± 4.0 to ± 18.0	V

■ Electrical Characteristics at V_{CC} = ±15 V, T_a = 25°C

Parameter	Symbol	Conditions	Min	Typ	Max	Unit
Total circuit current	I _{CC}	V _{IN} = 0 mV	8	12	16	mA
Voltage gain FLAT	G _{V(FLAT)}	f = 1 kHz, V _{IN} = -10 dBm	-0.6	-0.3	0	dB
Voltage gain BOOST	G _{V (BOOST)}	FLAT V _O = 0 dB, V _{IN} = -10 dBm	10.4	12.0	14.0	dB
Voltage gain CUT	G _{V(CUT)}	FLAT V _O = 0 dB, V _{IN} = -10 dBm	-14.0	-12.0	-10.4	dB
Total harmonic distortion	THD	f = 1 kHz, V _O = 1 V[rms]	-	0.002	0.03	%
Max. output voltage	V _{OM}	f = 1 kHz, THD = 0.1%	8.0	9.5	-	V[rms]
Output noise voltage	V _{NO}	Input short circuit DIN AUDIO	-	4	30	μV[rms]
Output noise voltage	V _{NOM}	Input short circuit DIN AUDIO All Boost	-	31	100	μV[rms]

■ Electrical Characteristics at $V_{CC} = \pm 15\text{ V}$, $T_a = 25^\circ\text{C}$ (continued)

• Design reference data

Note) The following characteristics are the reference values for design and not guaranteed values.

Parameter	Symbol	Conditions	Min	Typ	Max	Unit
Resonance frequency	f_{O1}	$V_{IN} = -10\text{ dBm}$, $V_O = G_V\text{ PEAK}$	47.3	57	73.6	Hz
Resonance frequency	f_{O2}	$V_{IN} = -10\text{ dBm}$, $V_O = G_V\text{ PEAK}$	93.3	113	145	Hz
Resonance frequency	f_{O3}	$V_{IN} = -10\text{ dBm}$, $V_O = G_V\text{ PEAK}$	285	347	444	Hz
Resonance frequency	f_{O4}	$V_{IN} = -10\text{ dBm}$, $V_O = G_V\text{ PEAK}$	0.851	1.04	1.32	kHz
Resonance frequency	f_{O5}	$V_{IN} = -10\text{ dBm}$, $V_O = G_V\text{ PEAK}$	1.98	2.41	3.08	kHz
Resonance frequency	f_{O6}	$V_{IN} = -10\text{ dBm}$, $V_O = G_V\text{ PEAK}$	5.23	6.37	8.14	kHz
Resonance frequency	f_{O7}	$V_{IN} = -10\text{ dBm}$, $V_O = G_V\text{ PEAK}$	12.4	15.1	19.3	kHz

■ Technical Information

• $P_D - T_a$ curves of SOP020-P-0300B

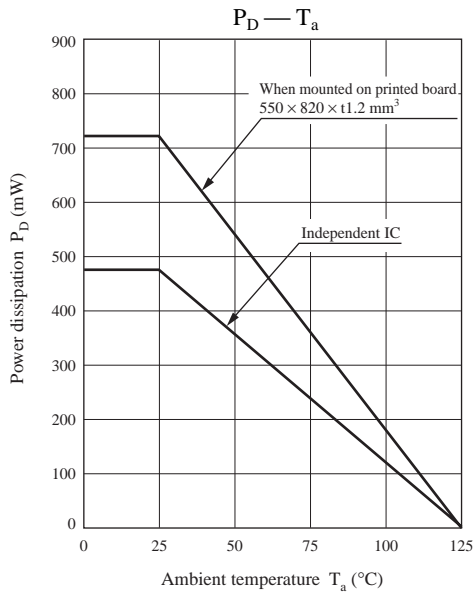



LittleDiode supplies new, hard to find or obsolete electronic components and semiconductors all over the world.

With over two million different components listed you are sure to find the part you need.

Feel free to visit us today at our online store:

LittleDiode.com

Looking forward to providing you with the best possible service.