

# AN7293NFBQ

## FM-IF, NC, MPX IC for Car Radio

### Overview

The AN7293NFBQ is an IC having FM-IF, NC and MPX function for car radio. A tuner block of car radio can be constructed by this IC and the AN7289NFBQ/NSC.

### Features

- A less number of external components is required (8 components reduction compared with our conventional IC)
- Neighboring-station interference characteristics improvement by band-ATC function
- Band-mute on/off function
- DIL package product (the AN7293NSC) is also available

### Applications

- Car radios

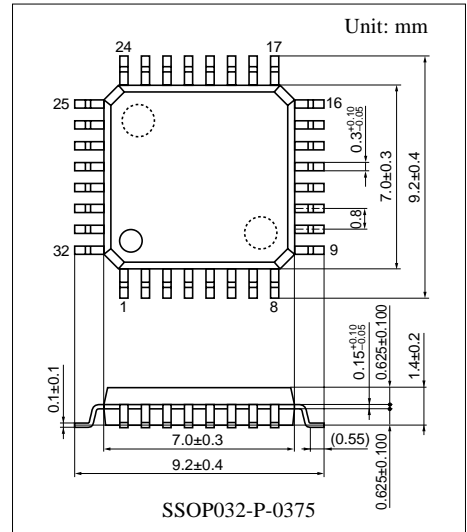

### Block Diagram

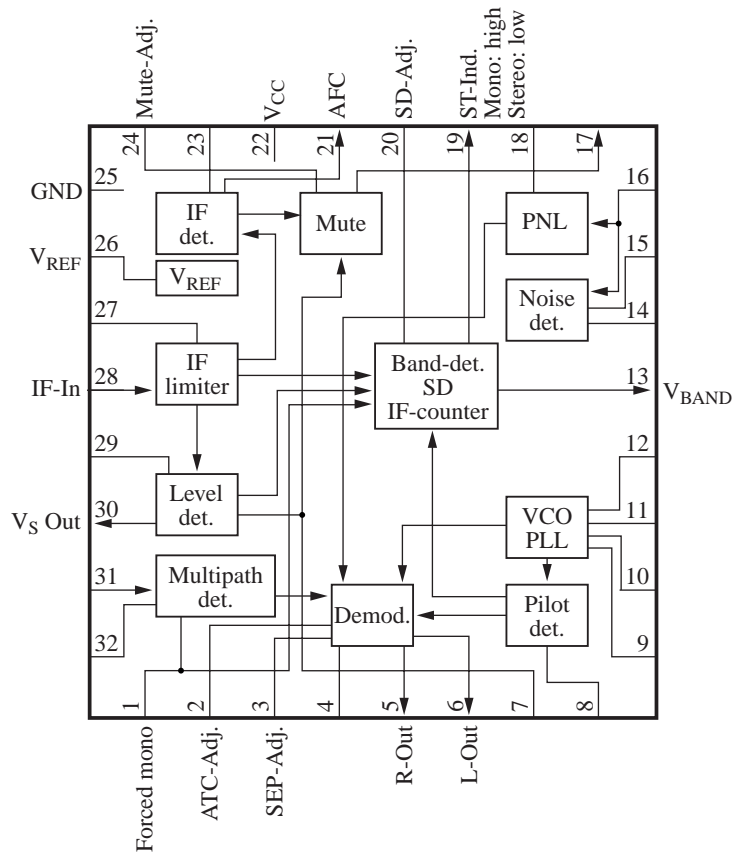

### ■ Pin Description

Pin No.	Description	Pin No.	Description
1	ASC adjustment/forced monaural	17	Detection output
2	ATC adjustment	18	PNL output hold
3	Separation adjustment	19	SD/FM-IF counter output/stereo indicator
4	ATC low-pass filter	20	SD sensitivity adjustment
5	R-ch. output	21	AFC voltage
6	L-ch. output	22	V <sub>CC</sub>
7	Mute voltage	23	FM detection
8	Pilot detection low-pass filter	24	Soft mute adjustment
9	PLL low-pass filter	25	GND
10	PLL low-pass filter	26	V <sub>REF</sub>
11	VCO	27	IF bypass
12	Pilot cancel control low-pass filter	28	IF input
13	Band signal output/band mute SW	29	Control voltage adjustment
14	PNL low-pass filter	30	Control voltage
15	PNL AGC	31	Multi-path noise input
16	PNL input	32	Multi-path detection

### ■ Absolute Maximum Ratings

Parameter	Symbol	Rating	Unit
Supply voltage	V <sub>CC</sub>	9.1	V
Supply current	I <sub>CC</sub>	45	mA
Power dissipation *2	P <sub>D</sub>	343.3	mW
Operating ambient temperature *1	T <sub>opr</sub>	-30 to +80	°C
Storage temperature *1	T <sub>stg</sub>	-55 to +125	°C

Note) \*1: Except for the power dissipation, operating ambient temperature, and storage temperature, all ratings are for T<sub>a</sub> = 25°C.

\*2: T<sub>a</sub> = 80°C

### ■ Recommended Operating Range

Parameter	Symbol	Range	Unit
Supply voltage	V <sub>CC</sub>	7.2 to 9.0	V

### ■ Electrical Characteristics at $T_a = 25^\circ\text{C}$

Unless otherwise specified,  $V_{CC} = 8\text{V}$ ,  $V_{IN1}$  is  $f = 10.70\text{ MHz}$ , Mod. =  $1\text{ kHz}$ , 30%

FM modulation stereo input is  $L + R = 90\%$   $V_P = 10\%$

Parameter	Symbol	Conditions	Min	Typ	Max	Unit
Control voltage (1)	$V_{C1}$	Without signal input, pin 30 DC voltage	0.0	0.3	0.9	V
Control voltage (2)	$V_{C2}$	$V_{IN1} = 40\text{ dB}\mu$ , pin 30 DC voltage	0.6	1.3	1.6	V
Control voltage (3)	$V_{C3}$	$V_{IN1} = 70\text{ dB}\mu$ , pin 30 DC voltage	2.4	3.1	3.8	V
Control voltage (4)	$V_{C4}$	$V_{IN1} = 100\text{ dB}\mu$ , pin 30 DC voltage	4.5	5.3	5.8	V
Control voltage (5)	$V_{C5}$	$V_{C5} = V_{C3} - V_{C2}$	1.8	2.0	2.2	V
Control voltage (6)	$V_{C6}$	$V_{C6} = V_{C4} - V_{C3}$	1.85	2.05	2.25	V
Output level L-channel	$V_{OL}$	$V_{IN1} = 70\text{ dB}\mu$ , pin 6 AC voltage	85	105	125	mV[rms]
Output level R-channel	$V_{OR}$	$V_{IN1} = 70\text{ dB}\mu$ , pin 5 AC voltage	85	105	125	mV[rms]
Channel balance	CB	$CB = 20 \cdot \log(V_{OL}/V_{OR})$	-1.0	0	1.0	dB
Residual pilot voltage	$V_{PC}$	$V_P = 10\%$ modulation, $V_{IN1} = 70\text{ dB}\mu$ , pin 18 output voltage	—	4	14	mV[rms]
Stereo lamp light up level	LAMP <sub>ON</sub>	19 kHz modulation, Modulation factor at which pin 19 becomes under 1 V	1.3	4.0	6.3	%
Separation L-channel	Sep <sub>L</sub>	L+R = 90%, $V_P = 10\%$ Larger separation value after changing over pin 3 external resistor	25	33	—	dB
Separation R-channel	Sep <sub>R</sub>		25	33	—	dB
Capture range	CR	Modulation at $V_P = 6.5\%$ Referred to 19 kHz	$\pm 0.4$	$\pm 0.7$	—	%
Counter output level (1)	VIF <sub>1</sub>	$V_{IN1} = 100\text{ dB}\mu$ , $V_{20} = 2\text{ V}$ pin 19 output voltage	135	155	175	mV[rms]
Counter output level (2)	VIF <sub>2</sub>	$V_{IN1} = 100\text{ dB}\mu$ , $V_{20} = 5\text{ V}$ pin 19 output voltage	0	2	5	mV[rms]
Monaural THD (L)	THD <sub>L</sub>	$V_{IN2}$ monaural input, 500 mV[0-p] 1 kHz, L-ch. output distortion factor	—	0.1	0.3	%
Monaural THD (R)	THD <sub>R</sub>	$V_{IN2}$ monaural input, 500 mV[0-p] 1 kHz, R-ch. output distortion factor	—	0.1	0.3	%
Stereo THD (L)	THD <sub>STL</sub>	$V_{IN2}$ stereo input, 500 mV[0-p] 1 kHz, L-ch. output distortion factor	—	0.1	0.3	%
Stereo THD (R)	THD <sub>STR</sub>	$V_{IN2}$ stereo input, 500 mV[0-p] 1 kHz, R-ch. output distortion factor	—	0.1	0.3	%
PNL-AGC voltage (1)	$V_{AGC1}$	$V_{IN2} =$ Without input pin 15 DC voltage	1.2	1.4	1.7	V
PNL-AGC voltage (2)	$V_{AGC2}$	$V_{IN2} = 100\text{ mV}$ , $f = 100\text{ kHz}$ input Difference from $V_{AGC1}$	0.1	0.35	0.60	V
Residual noise voltage	$V_{NR}$	$V_{IN2} =$ (pulse width 10 $\mu\text{s}$ , 1 V[p-p] 1 kHz) L-ch. output	0.0	0.2	0.7	mV[rms]

### ■ Electrical Characteristics at $T_a = 25^\circ\text{C}$ (continued)

Unless otherwise specified,  $V_{CC} = 8\text{V}$ ,  $V_{IN1}$  is  $f = 10.70\text{ MHz}$ , Mod. =  $1\text{ kHz}$ , 30%

FM modulation stereo input is L + R = 90%  $V_p = 10\%$

Parameter	Symbol	Conditions	Min	Typ	Max	Unit
SD sensitivity	$SD_S$	$V_{IN1}$ when $V_{20} = 2\text{ V}$ , $V_{19} > 2\text{ V}$	70	80	90	$\text{dB}\mu$
SD bandwidth	$SD_W$	$V_{IN}$ bandwidth when $V_{24} = 2\text{ V}$ , and $V_{19} > 2\text{ V}$ , $V_{IN1} = 100\text{ dB}\mu$	100	130	160	kHz
Supply current	$I_{TOT}$	Without input	30	37	44	mA
Limiting sensitivity	$V_{LIM}$	$V_{IN1}$ input level when pin 5 AC voltage drops by 3 dB	24	32	38	$\text{dB}\mu$
ATC	$V_{ATC}$	L-ch. output ratio when $V_2 = 2\text{ V}$ and $0\text{ V}$	7	11	15	dB
Gate pulse width	PW	$V_{IN2} = (\text{pulse width } 1\ \mu\text{s}, 0.3\text{ V}[\text{p-p}] 1\text{ kHz})$ pin 18 output pulse width	16	23	30	$\mu\text{s}$

### • Design reference data

Note) The following characteristics are the reference values for design and not guaranteed values.

Parameter	Symbol	Conditions	Min	Typ	Max	Unit
Stereo lamp turn off level	$LAMP_{OFF}$	Ratio between the modulation factor when pin 19 becomes 2 V or more and $LAMP_{ON}$	2.0	6.0	10.0	dB
AFC offset voltage	$V_{AFC}$	Without signal input, DC potential difference between pin 21 and pin 26.	-0.1	0.0	0.1	V

■ Application circuit Example

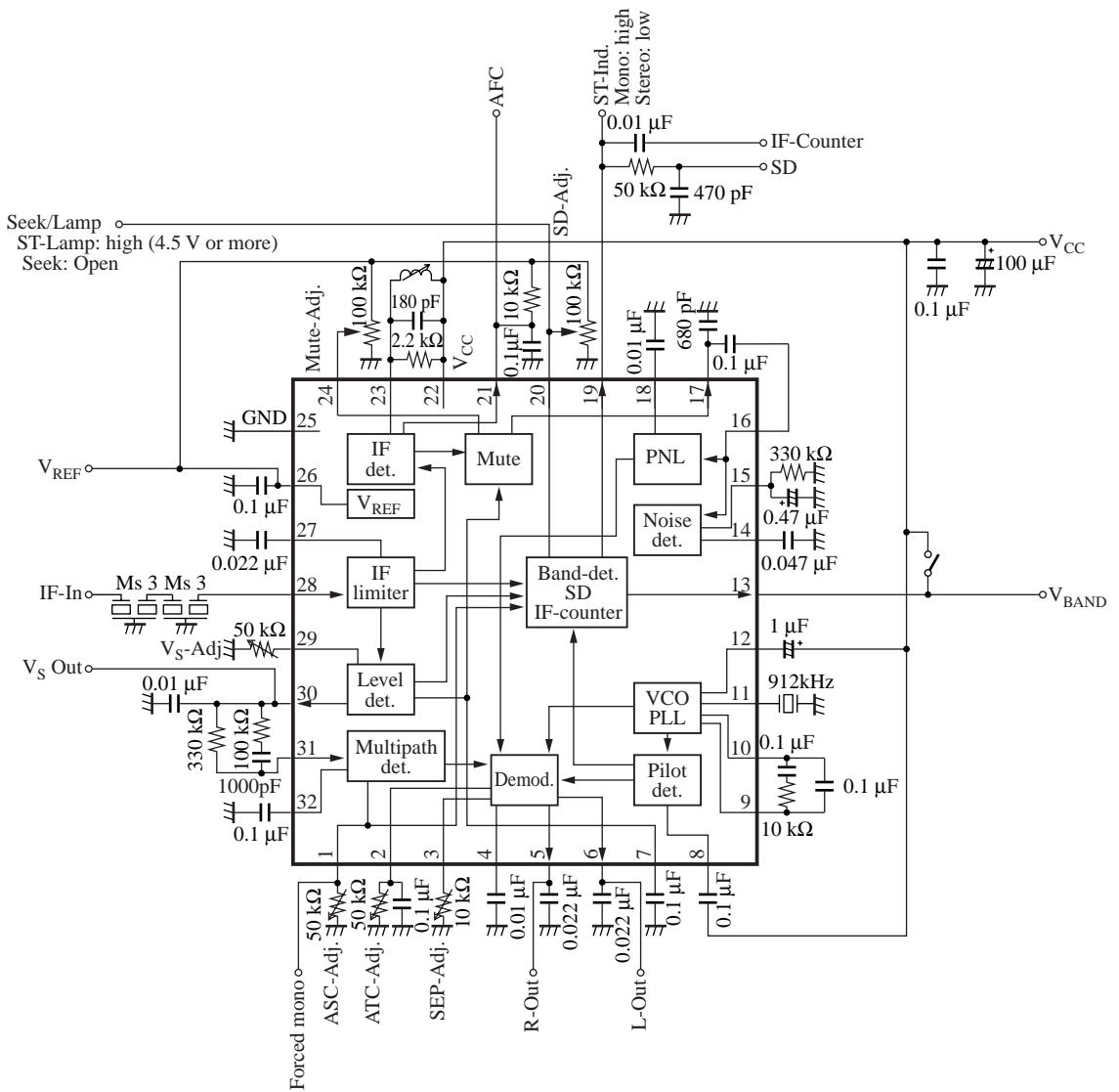



LittleDiode supplies new, hard to find or obsolete electronic components and semiconductors all over the world.

With over two million different components listed you are sure to find the part you need.

Feel free to visit us today at our online store:

**[LittleDiode.com](http://LittleDiode.com)**

Looking forward to providing you with the best possible service.