

Designing with the Si9976DY N-Channel Half-Bridge Driver and LITTLE FOOT® Dual MOSFETs

Wharton McDaniel

INTRODUCTION

The Si9976DY is a fully integrated half-bridge driver IC which was designed to work with the LITTLE FOOT family of power MOSFET products in 20- to 40-V systems. The Si9976DY provides the gate drive for both the low- and high-side MOSFETs while the Si9945 (SO-8, 3.3 A) or Si4946EY (SO-8, 4.5 A) dual n-channel LITTLE FOOT MOSFETs provide power handling capability without the need of a heatsink. All of these devices are supplied in surface-mount packages. The combination of the Si9976DY and one of the dual n-channel MOSFETs creates a powerful and flexible solution for power switching in dc motor drives.

SI9976DY OVERVIEW

The Si9976DY is an integrated driver for an n-channel MOSFET half-bridge (see Figure 1). Schmitt trigger inputs

provide logic signal compatibility and hysteresis for noise immunity. Low impedance outputs are provided to drive both the low- and high-side MOSFETs of the half-bridge. The addition of a bootstrap capacitor allows the internal circuitry to level shift both the power supply and the logic signals that are required for the high-side n-channel MOSFET gate drive. A charge pump has been included to replace the leakage current in the high-side driver, which allows static (dc) operation.

A separate voltage input, V_{CC} , powers the FAULT output to allow easy interfacing to the user's system. Protection circuits include an undervoltage lockout to assure safe gate-drive levels, timing delays to prevent cross-conduction, and a monitor for short circuits on the half-bridge output (S1). An internal voltage regulator drops the input voltage ($V+$) to a nominal 16 V for the low-side circuitry, which allows the Si9976DY to operate over an input voltage range of 20 to 40 V. The device is specified over the industrial temperature range (-40° to $+85^{\circ}\text{C}$).

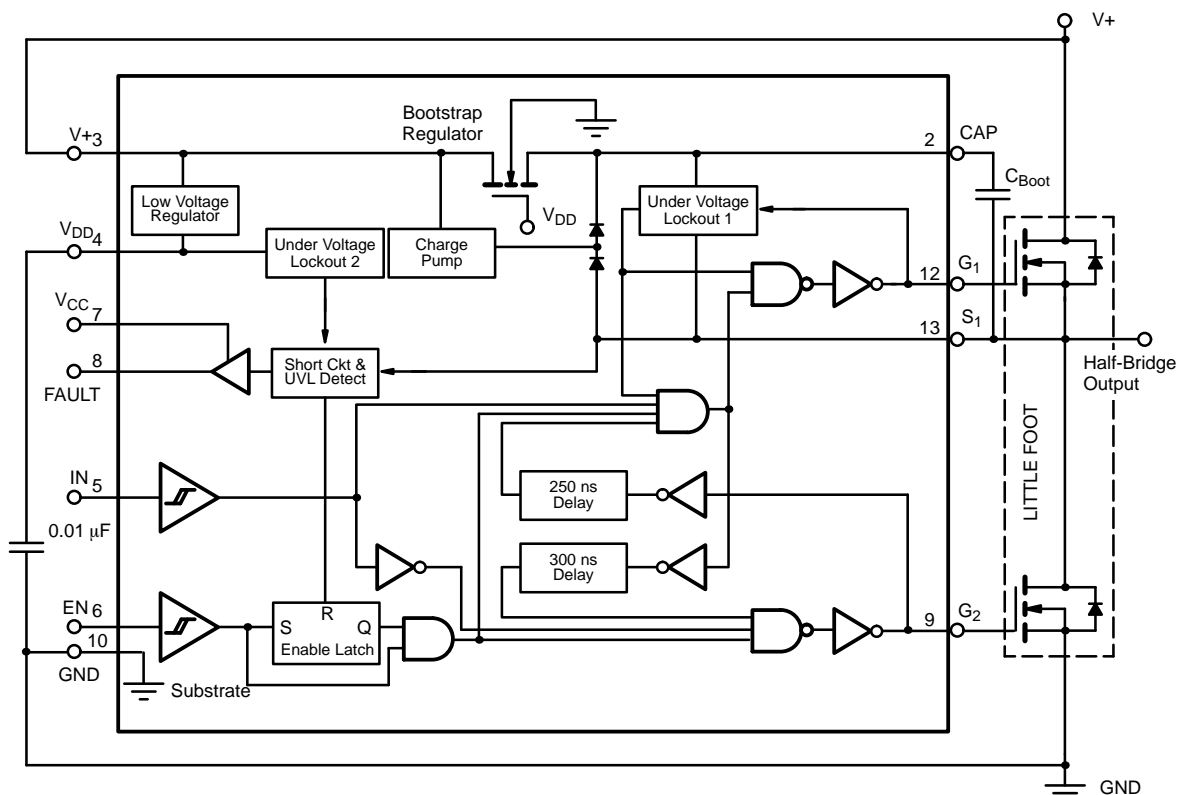

Figure 1. Si9976DY Functional Block Diagram

TABLE 1: RECOMMENDED VALUES

Part Number	$r_{DS(on)}$	$Q_g @ V_{GS} = 10\text{ V}$ (nC)	Minimum Recommended C_{BOOT} (μF)
Si4946EY	0.055	30	0.039
Si9945	0.10	15	0.018

Table 1 shows the selected bootstrap capacitor for each MOSFET was selected using the method described, with a switching frequency of 20 kHz.

If a shorter recharge time is required, an external signal diode can be added from V_{DD} to the positive side of the bootstrap capacitor (CAP). This increases the charging current, especially at the lower values of V_+ . Also, the value of the capacitor on V_{DD} should be increased, since this is the source of the additional charging current.

The low-side drive circuitry operates directly from V_{DD} and does not have recharge requirements. The capacitor connected to V_{DD} supplies the charge required to turn on the low-side MOSFET. It must be sized to ensure that V_{DD} does not drop below 14 V, which would trigger an undervoltage condition. As in the case of the bootstrap capacitor, the V_{DD} bypass capacitor should be sized such that it will hold 10 times the charge required by the MOSFET at a $V_{GS} = 10\text{ V}$ ($C = 10 \times Q_g / V_{GS}$). The Si9945 requires a 15-nC charge for turn on with $V_{GS} = 10\text{ V}$. Therefore, a 0.018 μF capacitor will work well. Since the requirements for value selection are the same as for the bootstrap capacitor, the recommended values in Table 1 also apply to the V_{DD} bypass capacitor. If an external bootstrap diode is used to reduce the bootstrap capacitor recharge time, the value of the V_{DD} bypass capacitor should be doubled. This compensates for the additional load of recharging the bootstrap capacitor and prevents the occurrence of an undervoltage condition.

CROSS CONDUCTION PROTECTION

Turn-on delays have been incorporated to prevent cross conduction of the half-bridge MOSFETs (Figure 3). The high-side MOSFET can be turned on only after a 250-ns time delay, which is initiated by the low-side output, G_2 , switching to ground. The low-side MOSFET can be turned on only after a 300-ns delay which is initiated by the high-side control logic. These delays prevent one half-bridge MOSFET from turning on before the other is completely turned off. The difference in the method of generating the delays occurs because the high-side output, G_1 , is level shifted with respect to S_1 .

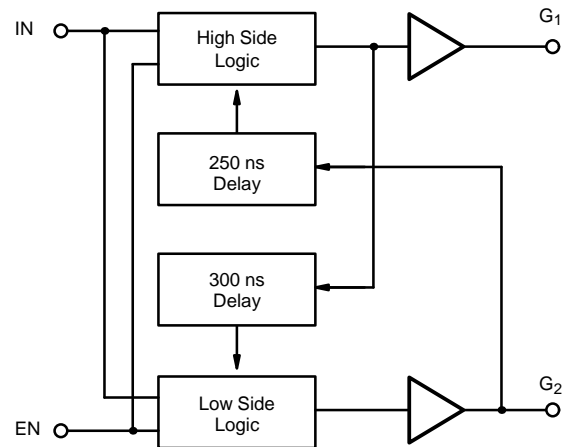
Figure 3. Cross Conduction Protection

UNDERVOLTAGE LOCKOUT

During power up, both MOSFETs are held off until the internal power supply, V_{DD} , is within approximately 0.7 V of the final value, which is nominally 16 V. After power up, the low-side undervoltage lockout circuitry, UVL2, continues to monitor V_{DD} . If an undervoltage condition occurs, both the high-side and the low-side MOSFETs will be turned off, and the FAULT output will be high. When the undervoltage condition no longer exists, the FAULT output will be cleared and normal function will resume.

A separate undervoltage lockout circuit, UVL1, monitors the bootstrap voltage. If an undervoltage condition exists when the IN line is switched high, this circuit will prevent the high-side MOSFET from turning on. In addition, one of the following conditions will exist. If S_1 is high (as the result of inductive flyback current through the high-side MOSFET's body-drain diode or a short from S_1 to V_+), the high-side MOSFET will be allowed to turn on as soon as the undervoltage condition has been removed. If S_1 is low, the high-side MOSFET will be allowed to turn on only after the undervoltage condition has been removed and the IN line has been toggled low and back to high.

SHORT CIRCUIT PROTECTION

If the load voltage, S_1 , does not make the intended transition through $\frac{1}{2} V_{DD}$ to either ground or V_+ before a specified time, the Si9976DY sees this as an output short circuit (Figure 4). The transition should take place in less than 300 ns for a transition to V_+ , and 200 ns for a transition to ground. Detection of a short circuit condition latches both outputs off and the fault line high. The outputs are re-enabled by a rising edge on the enable line, EN.

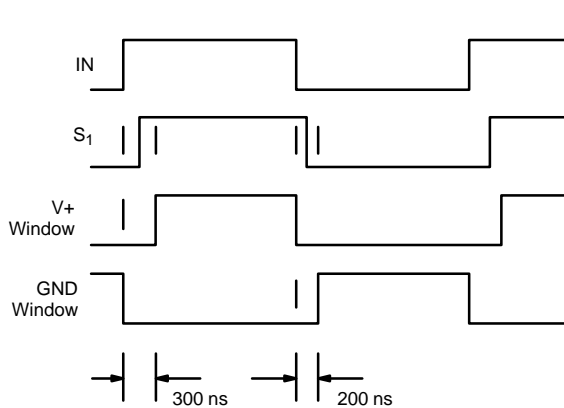
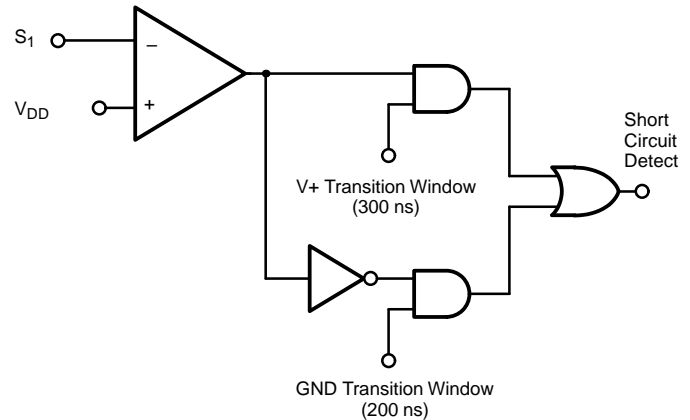

Figure 4. Short Circuit Protection



FAULT OUTPUT

The FAULT output goes high whenever the Si9976DY detects an output short circuit or a V_{DD} undervoltage condition. The detection of the short circuit inhibits operation and sets a fault latch which is cleared by a rising edge on the enable line, EN. The V_{DD} undervoltage condition inhibits operation and indicates a fault but is nonlatching.

TABLE 2: FAULT OUTPUT TRUTH TABLE					
EN	IN	Condition	FAULT Output	G1 Out	G2 Out
1	0	Normal Operation	0	Low	High
1	1	Normal Operation	0	High	Low
0	X	Disabled	X	Low	Low
1	0	Load Shorted to V+	1	Low	Low
1	1	Load Shorted to Ground	1	Low	Low
1	1	Undervoltage on C_{BOOT}	0	Low	Low
1	0	Undervoltage on C_{BOOT}	0	Low	High
X	X	Undervoltage on V_{DD}	1	Low	Low

The system-logic supply voltage of 4.5 to 16.5 V can be applied to V_{CC} to facilitate interfacing of the FAULT output to the user's system. If V_{CC} is not supplied, there will be no signal on the FAULT output. However, the fault protection circuitry will continue to function as described.

PWM CIRCUITS IN H-BRIDGES

Anti-Phase Control

The Si9976 was designed to be used in an anti-phase control strategy. This approach is unique in that the PWM signal controls both speed and direction with duty cycle alone. Zero

to 50% duty cycle defines zero to full speed in one direction, 50% duty cycle is zero speed, and 50% to 100% duty cycle defines zero to full speed in the opposite direction. This approach ensures that the bootstrap capacitor is always charged, since the H-bridge is continuously switching.

The basic hook-up of an anti-phase H-bridge is very simple. One half-bridge is driven directly with the PWM signal, and the other half-bridge is driven with the inverse of the PWM signal (see Figure 5).

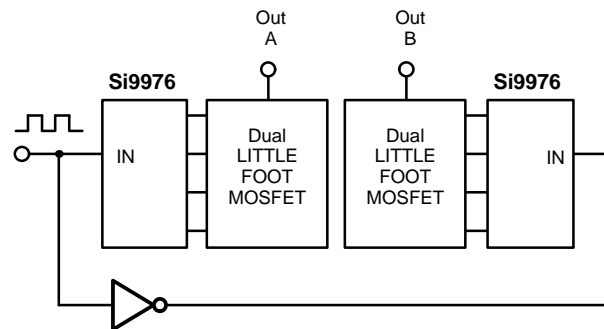
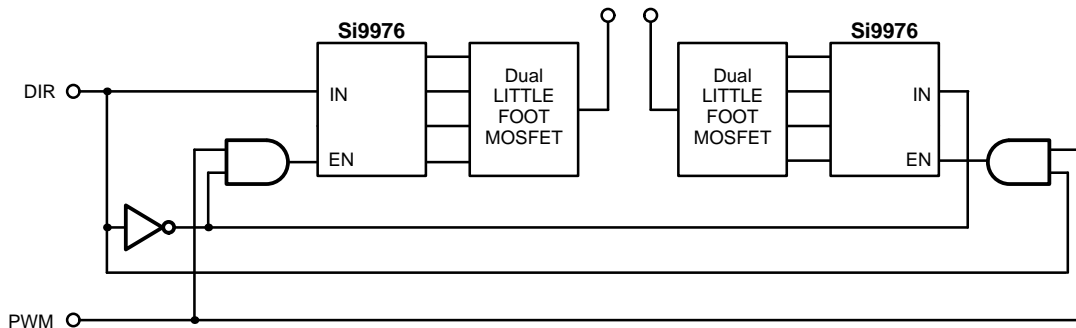
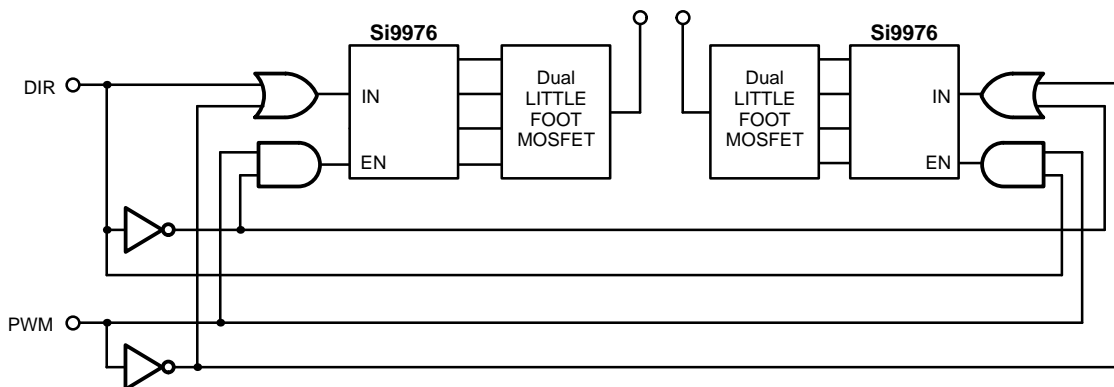

Figure 5. Anti-Phase Control

Sign-Magnitude Control

As a secondary function, the Si9976 can be used in sign-magnitude controls. In this approach, direction of rotation is determined by the diagonal pair of MOSFETs that are turned on, and speed is controlled by pulse width modulation of the active diagonal pair.

The logic required to control the H-bridge is more complex due to the need to steer the pulse width modulation signal to the active MOSFET pair. The circuit in Figure 7a applies the PWM signal only to the low-side active MOSFET.

Figure 7a. Sign-Magnitude Control

Figure 7b. Sign-Magnitude Control for Low-Side MOSFET PWM

There are a couple of things to be aware of in this mode of operation. Application of the PWM signal to the EN input when the IN input is held low will create an erroneous Fault signal which is the inverse of the PWM signal. This can be eliminated by applying the inverse of the PWM signal to the IN input as shown in Figure 7b. Secondly, care must be taken to ensure that the bootstrap capacitor has been charged prior to a high-side turn on. As low-side on-times decrease, this becomes of greater concern. Minimum low-side on-times must be observed to ensure that the high-side will turn on. Remember that this minimum time can be reduced by adding an external bootstrap diode (see Figure 8). When this is done, it increases the load on V_{DD} and therefore on the decoupling capacitor. The value of the V_{DD} decoupling capacitor should be doubled to prevent an undervoltage condition from occurring.

BRAKING

Braking is accomplished by turning on both upper or both lower MOSFETs in the H-bridge so the motor windings are shorted together. If the upper MOSFETs are used for this function, be certain that the bootstrap capacitors are charged prior to turning them on.

CURRENT SENSING

If current sensing is required, a fractional Ω resistor can be inserted in between the low-side MOSFET source connection and ground. External op amps or comparators can then be used to implement current limit or some other current control. A Schottky diode must be connected from the half-bridge output to ground to protect output from negative voltage spikes. In addition to causing potential damage to the Si9976, negative spikes can cause an erroneous latching FAULT. The sensing resistor provides a small amount of isolation of the MOSFET decoupling capacitors from ground. Make sure that decoupling capacitors on MOSFETs are connected directly across the MOSFET pair, high-side drain to low-side source to maximize their effectiveness at reducing noise (see Figure 7).

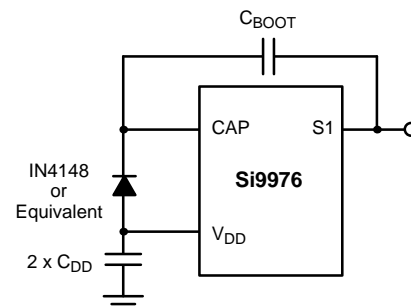
Figure 6. External Bootstrap Diode

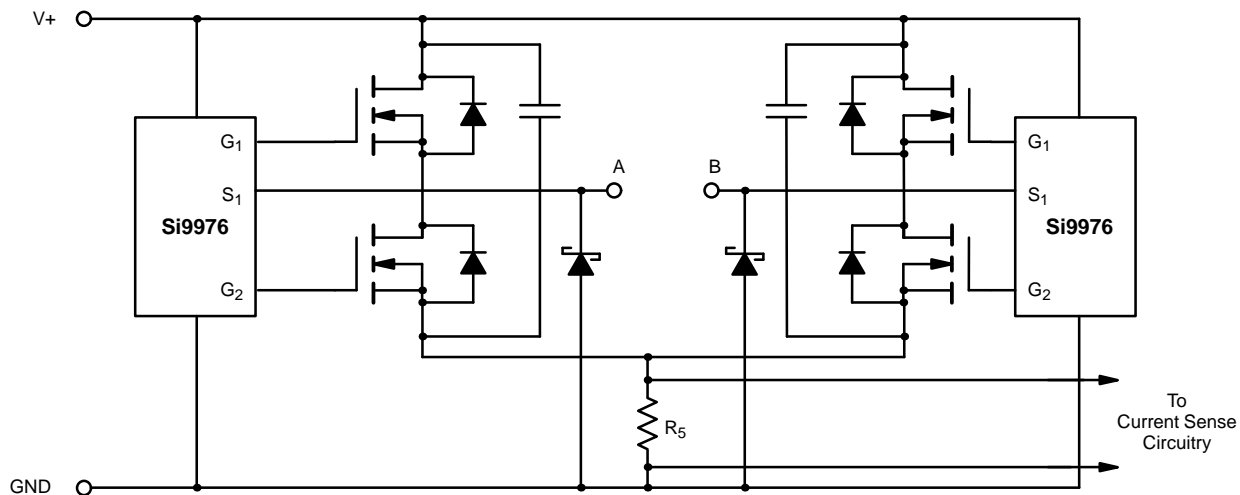

Figure 7. Current Sensing

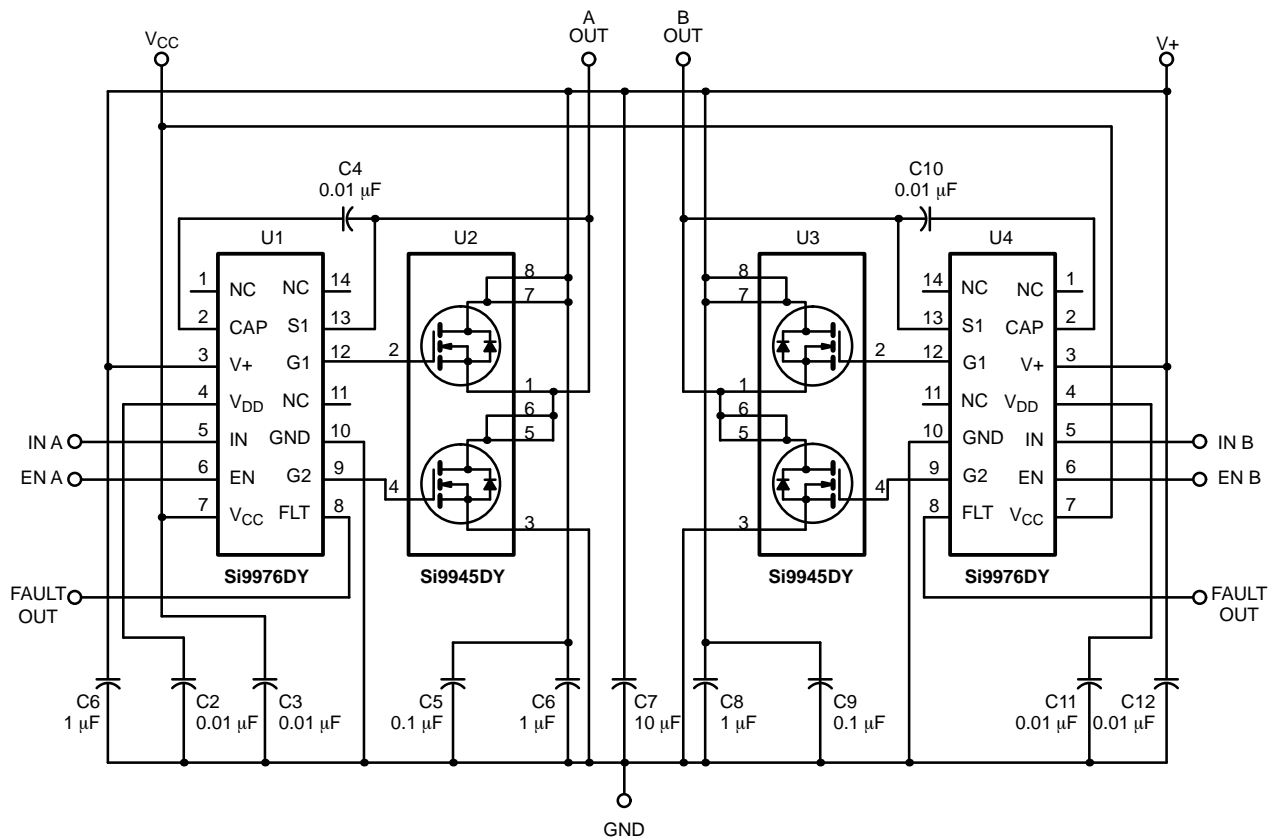

Figure 8 Full-Bridge Configuration with the Si9976DY and the Si9945DY

A FULL-BRIDGE APPLICATION

Figure 8 shows a basic implementation of the Si9976DY and Si9945DY in a full-bridge configuration. Each half-bridge is made up of one Si9976DY driver IC, one Si9945DY LITTLE FOOT dual n-channel MOSFET, a bootstrap capacitor, a filter capacitor for V_{DD} , and decoupling capacitors for each IC. This configuration yields a full-bridge circuit with a continuous current rating of 3 A without heatsinking. Use of the Si9945DY or the Si4946EY yields current ratings of 3.7 A or 4.5 A, respectively.

Any circuit which generates signals with fast rise and fall times can generate noise. This noise, if not dealt with, can affect the operation of the circuit. Proper PC board layout techniques and device decoupling will take care of these problems. The signal ground trace from the Si9976DY and the trace from the low-side MOSFET source should be run separately to the common ground point. This prevents the noise generated by fast MOSFET transitions from modulating the signal ground of the Si9976DY. Similarly, the trace to the $V+$ input of the Si9976DY and the trace to the drain of the high-side MOSFET should be connected separately to the supply bypass capacitor.

In addition to layout considerations, decoupling capacitors are required to deal with noise. Adding capacitors across the power supply lines, $V+$, V_{DD} , and V_{CC} , provides a low impedance to ground for switching noise and serves as a local energy reservoir when there is a demand for surge current. The V_{DD} capacitor provides the surge current required to turn on the low-side MOSFET.

In addition to basic decoupling, the capacitors added across the half-bridge itself minimize the surge current in the power supply traces, and therefore reduce the generated noise. Although a single capacitor, typically 0.01 μF , works well to decouple a single pin, it is advisable to apply several decades of capacitance across the input power, $V+$ to GND, to handle the broad spectrum of noise that can be present. The high-frequency (lower value) capacitors should be located as close as possible to the device being decoupled, while the

larger capacitors ($> 1 \mu\text{F}$) can be located farther away and bypass only the power supply.

Figure 9 shows a typical layout for a Si9976DY with LITTLE FOOT dual n-channel MOSFETs. The use of surface-mount packages allows automated assembly of the entire motor drive circuit, without the need for a separate heatsink and its associated material and assembly costs.

SUMMARY

The Si9976DY provides both low- and high-side gate drive, high-side level shifting, a bootstrap/charge pump high-side power supply, and protection for undervoltage and short circuit conditions in a single surface-mount IC. The Si4946EY, Si9945DY, are Si9945DY are surface-mount MOSFETs for power switching over a broad current range (2 to 5 A) and require no heatsinking. The use of surface-mount packages allows automated assembly of the entire drive system while minimizing use of PC board space. The Si9976DY, when used with one of the dual n-channel LITTLE FOOT power MOSFETs, provides a very flexible approach to power switching in dc motor drives.

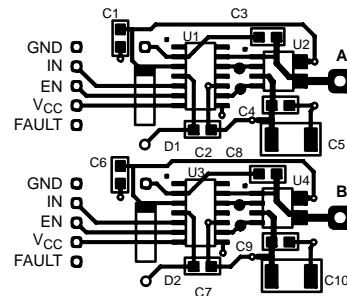

Figure 9 Typical PC Board Layout (Scale 1:1)



LittleDiode supplies new, hard to find or obsolete electronic components and semiconductors all over the world.

With over two million different components listed you are sure to find the part you need.

Feel free to visit us today at our online store:

LittleDiode.com

Looking forward to providing you with the best possible service.