

AN7017S, AN7017SB

FM/TV Front-end ICs for 1.5V Headphone Stereo, Radio Cassette Recorder

■ Overview

The AN7017S and the AN7017SB are the ICs incorporating FM/TV front-end most suitable for headphone stereo.

Sealed in a 16-pin flat package, the chip operates stably at TV band (170MHz ~ 222MHz) FM band (76MHz ~ 108MHz).

RF amplifiers and oscillations are provided in FM/TV band individually, and are designed most suitably. So both characteristics of FM/TV band are satisfied.

■ Features

- Low current consumption
- Band switching circuit built-in
- A single chip integrating FM/TV band
- IF amp. built-in

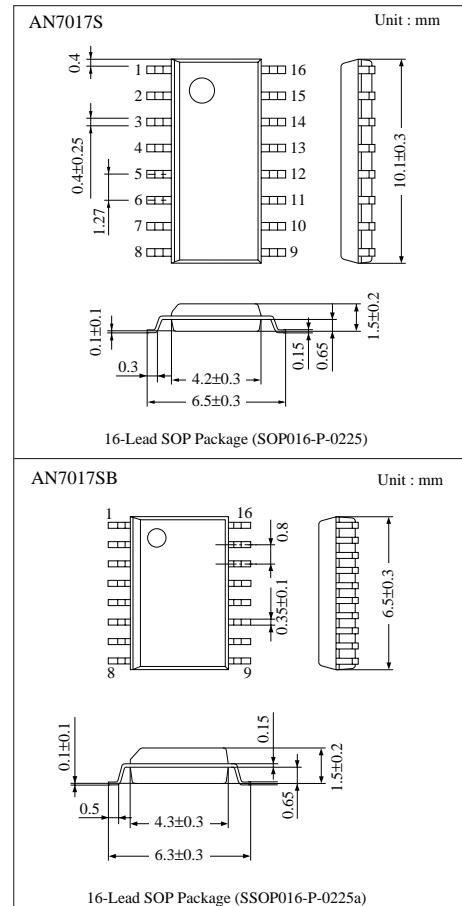

■ Block Diagram

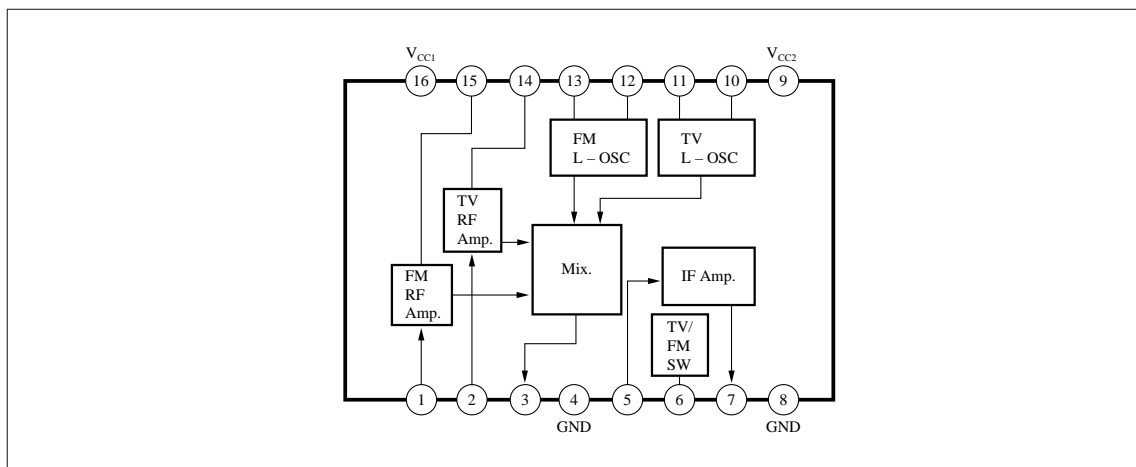

■ Absolute Maximum Ratings (Ta=25°C)

Parameter	Symbol	Rating	Unit
Supply Voltage	V _{CC}	2.5	V
Supply Current	I _{CC}	10	mA
Power Dissipation	P _D	30	mW
Operating Ambient Temperature	T _{opr}	-22 ~ + 75	°C
Storage Temperature	T _{stg}	-55 ~ + 125	°C

■ Recommended Operating Range (Ta=25°C)

Parameter	Symbol	Range
Operating Supply Voltage Range	V _{CC}	1V ~ 2V

■ Electrical Characteristics (V_{CC}=1.2V, Ta = 25°C)

Parameter		Symbol	Condition	min.	typ.	max.	Unit
FM	No Signal Current	I _{tot} (FM)	Note) V _{CC} =1V V _{in} = 60dBμ	—	2.5	—	mA
	Conversion Gain	G _{conv} (FM)		—	31	—	dB
	Oscillation Voltage	V _{osc} (FM)		—	73	—	mV
	S/N	S/N (FM)		—	55	—	dB
TV	No Signal Current	I _{tot} (TV)	Note) V _{CC} =1V V _{in} =60dBμ	—	3.2	—	mA
	Conversion Gain	G _{conv} (TV)		—	27	—	dB
	Oscillation Voltage	V _{osc} (TV)		—	57	—	mV
	S/N	S/N (TV)		—	53	—	dB

Note) Conversion Gain= 20log (ΔV_(μV) ÷ 100)
 ΔV is output difference at 40dBμ and 46dBμ.

■ Characteristics Curve

Supply Voltage Characteristics (FM)–
 Oscillation Frequency Deviation
 S/N, S/N Sensitivity, Limiter Sensitivity, I_{tot}

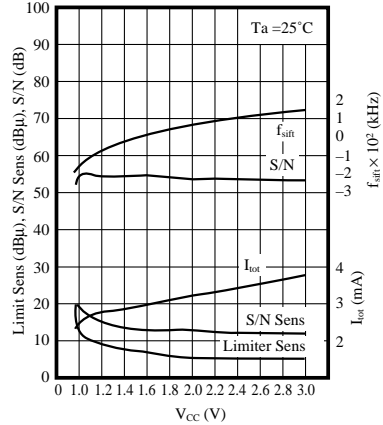

Input/Output Characteristics –
 S/N, V_{out}

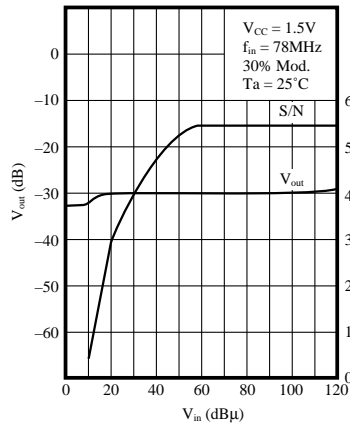

Frequency Characteristics (FM) –V_{osc}, S/N Sensitivity,
 Limiter Sensitivity

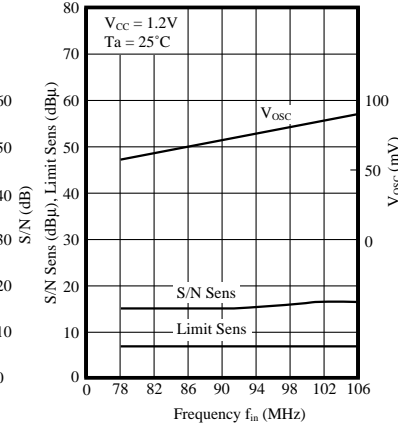

■ Pin Descriptions

Pin No.	Pin Name	Typ.Waveform	Description	Equivalent Circuit
1	FM RF Input	FM signal	FM RF input pin	
15	FM RF Output	FM signal	FM RF output pin	
4	GND	DC 0V	GND pin Used for RF amp. /Mixer.	—
3	Mix. Output	10.7MHz IF signal	Mix. output pin Ceramic Filter connect to output.	
5	IF Input	10.7MHz IF signal	IF input pin	
6	TV/FM switch	—	TV/FM switching At FM, stop the current source of TV circuit by connecting Pin6 to V _{CC} , and at TV, stop the current source of FM circuit by opening this.	
7	IF Output	10.7MHz IF signal	IF output pin	
8	GND	—	GND pin Used for IF amp. /oscillation circuit current source	—

■ Pin Descriptions (Cont.)

Pin No.	Pin Name	Typ.Waveform	Description	Equivalent Circuit
9	V _{CC2}	DC 1.5V	Supply voltage pin Used for IF amp. /oscillation circuit current source	—————
10 · 11	TV OSC	160MHz ~ 216MHz oscillation	TV OSC pin	
12 · 13	FM OSC	65MHz ~ 96MHz oscillation	FM OSC pin	
2	TV RF Input	TV signal	TV RF input pin	
14	TV RF Output	TV signal	TV RF output pin	
16	V _{CC1}	DC 1.5V	Supply voltage pin Used for RF amp., mixer	—————



LittleDiode supplies new, hard to find or obsolete electronic components and semiconductors all over the world.

With over two million different components listed you are sure to find the part you need.

Feel free to visit us today at our online store:

LittleDiode.com

Looking forward to providing you with the best possible service.