

AN6857N

High Speed 8-bit AD Converter

■ Outline

The AN6857N is an A/D-converting parallel 8-bit monolithic bipolar IC with a high speed and low power consumption. It is suitable for A/D conversion of video band signals.

■ Features

- 8-bit resolution (with overflow)
- High speed : maximum conversion speed 35 MSPS
- Sample & hold circuits not necessary
- Input dynamic range : $2V_{P-P}$
- Low power dissipation : 780mW typ.
- Digital inputs and outputs ECL compatible
- 8-bit parallel output (pure binary)

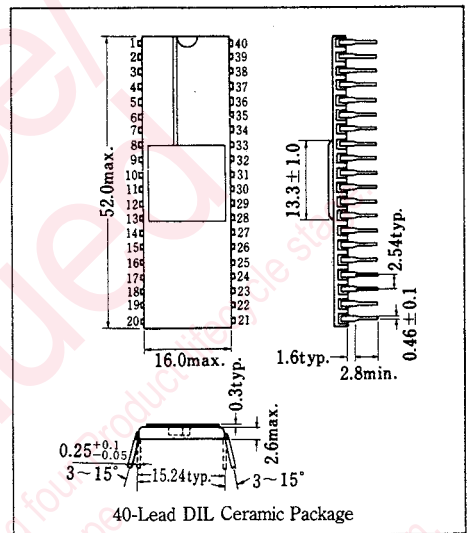

■ Quick Reference Data ($V_{EE} = -5.2V$, $T_a = 0 \sim 70^\circ C$)

Item	Symbol	Condition	Value	Unit
Resolution	RES		8	bit
Input dynamic range	$V_{in(max)}$		2	V
Linearity error	LE	$V_i = 2V_{P-P}$	$\pm \frac{1}{2}$	LSB
Max. conversion speed	$f_{MSPS(max)}$		35	MSPS
Quantization noise	S/N	$f_s = 14.32 \text{ MHz}, f_{IN} = 1 \text{ MHz}$	48	dB
		$f_s = 14.32 \text{ MHz}, f_{IN} = 4 \text{ MHz}$	40	dB
Differential gain	DG	IRE Standard 15kHz Sawtooth, 40% subcarrier	1	%
Differential phase	DP	$f_s = 14.32 \text{ MHz non-lock}$	0.5	deg

■ Block Diagram

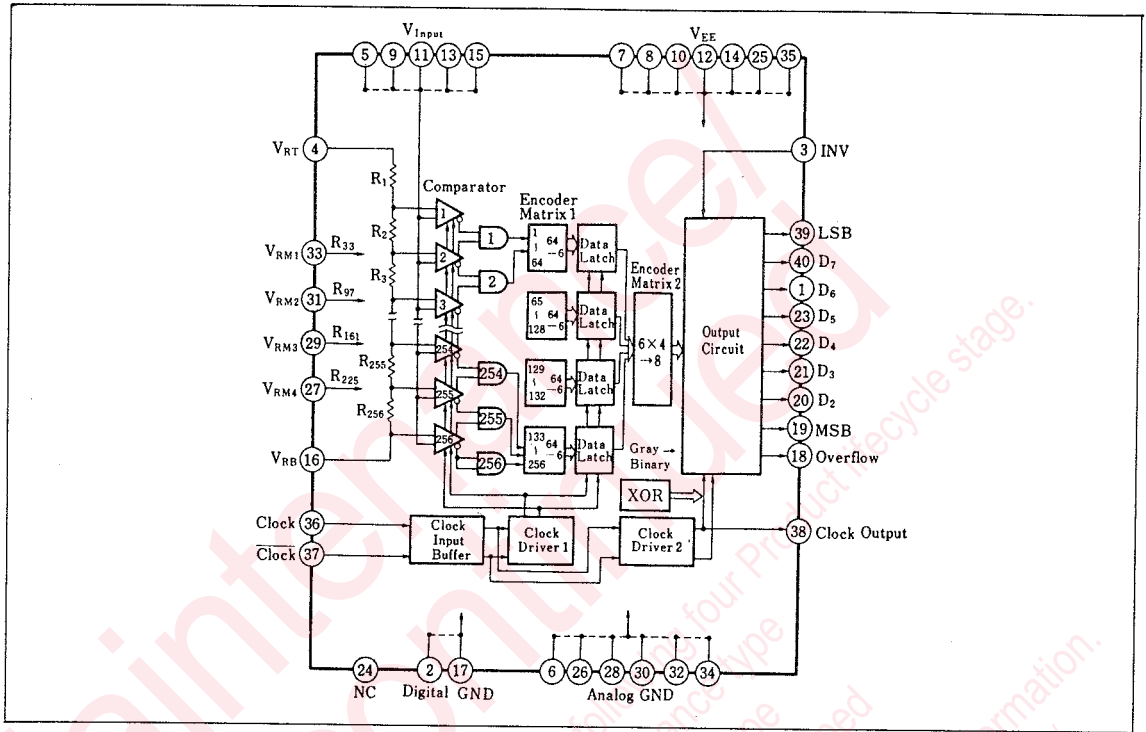

■ Pin

Pin No.	Pin Name	Pin No.	Pin Name
1	6th bit	21	3rd bit
2	Digital GND	22	4th bit
3	Output Inversion	23	5th bit
4	Ref. High Level	24	NC
5	Analog Input	25	VEE
6	Analog GND	26	Analog GND
7	VEE	27	Linearity Control
8	VEE	28	Analog GND
9	Analog Input	29	Linearity Control
10	VEE	30	Analog GND
11	Analog Input	31	Linearity Control
12	VEE	32	Analog GND
13	Analog Input	33	Linearity Control
14	VEE	34	Analog GND
15	Analog Input	35	VEE
16	Ref. Low Level	36	Clock Input (Positive)
17	Digital GND	37	Clock Input (Negative)
18	Over Flow	38	Clock Output
19	1st bit (MSB)	39	8th bit (LSB)
20	2nd bit	40	7th bit

■ Absolute Maximum Ratings (Ta=25°C)

Item	Symbol	Rating	Unit
Supply voltage	V _{EE}	-7 ~ +0.5	V
Analog input voltage	V _{ia}	V _{EE} ~ +0.5	V
Digital input voltage	V _{id}	V _{EE} ~ +0.5	V
Reference voltage	V _{REF}	V _{EE} ~ +0.5	V
Power consumption	P _D	1.2	W
Operating ambient temperature	T _{opr}	0 ~ +70	°C
Storage temperature	T _{stg}	-50 ~ +150	°C

■ Recommended Operating Conditions

Item	Symbol	min.	typ.	max.	Unit
Supply voltage	V _{EE}	-5.4	-5.2	-5.0	V
Reference voltage	V _{RT}	-0.1	0	+0.1	V
	V _{RB}	-2.1	-2.0	-1.9	V
Analog input voltage	V _i	-2.1		+0.1	V
Digital input voltage	V _{φH}	-1.105			V
	V _{φL}			-1.475	V
Digital output current	I _{OH}	-1	-2	-5	mA
Clock input pulse width (CLOCK IN)	τ _H	10			ns
	τ _L	20			ns

* INV terminal also acceptable even when V_{IH}=0V, V_{IL}=Open

■ Electrical Characteristics (V_{EE}=-5.2V, Ta=25°C)

Item	Symbol	Test Circuit	Condition	min.	typ.	max.	Unit
Supply current	I _{EE}		V _{EE} =-5.2V	-200	-150		mA
Reference resistance current	I _{RT}		V _{RT} =0V, V _{RB} =-2V		+25	+40	mA
	I _{RB}			-40	-25		mA
Equivalent input resistance	R _i *1		V _{EE} =-5.2V	10			kΩ
Input capacitance	C _i *1		Total of analog input end		100	150	pF
Input bias current	I _{Bias} *1		V _{EE} =-5.2V		125	250	μA
Clock input current	I _{φH}		I ₃₆ when V ₃₆ =-5.2V, I ₃₆ when V ₃₆ =0V			+0.6	mA
	I _{φL}		I ₃₇ when V ₃₇ =-5.2V, I ₃₇ when V ₃₇ =0V	-0.01			mA
Digital output voltage	V _{OH}		V _{EE} =-5.2V, I _{OH} =-2mA,	-0.96			V
	V _{OL}		I _{OL} =-2mA			-1.65	V
Digital output delay time	τ _d				10	15	ns
Linearity error	LE	1				± 1/2	LSB

*1 Design specification

Test Circuit 1 (LE)

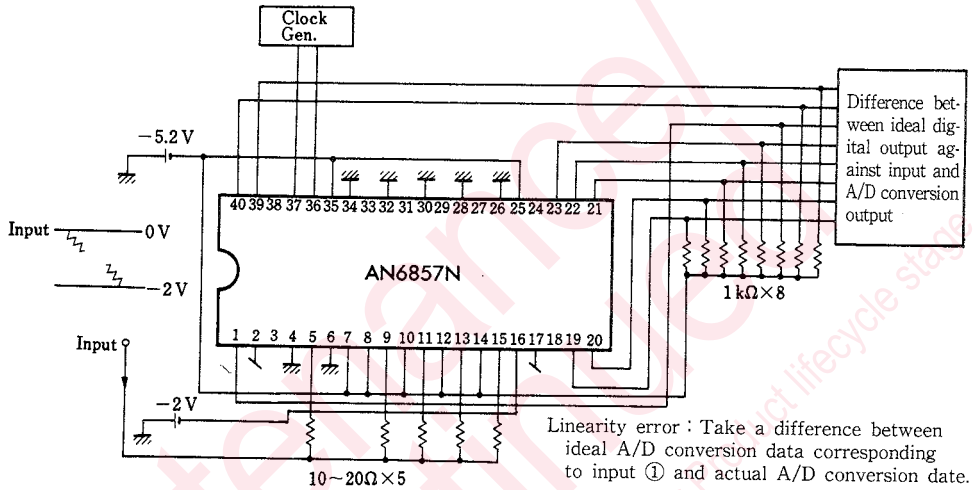

■ Sampling Diagram

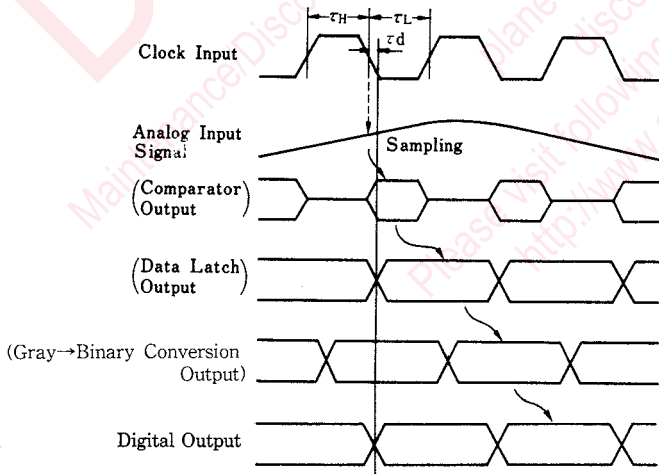

Note) Those in parentheses have no external terminal, because they are internal signals.

■ Output Cord Table

Comparator No.	Comparator Threshold Voltage		Digital Output																								
	Input 2.0000 VFS 7.8125 mV _{STEP}	Input 2.0480 VFS 8.0000 mV _{STEP}	INV. Terminal "L" Over M Flow 1 2 3 4 5 6 7 8							INV. Terminal "H" Over M Flow 1 2 3 4 5 6 7 8																	
001	-0.00781V	-0.0080V	0	0	0	0	0	0	0	0	0	0	0	0	0	1	1	1	1	1	1	1	1	1	1	1	1
002	-0.01562	-0.0160	0	0	0	0	0	0	0	0	0	0	0	0	0	1	1	1	1	1	1	1	1	1	1	1	1
⋮	⋮	⋮	⋮	⋮	⋮	⋮	⋮	⋮	⋮	⋮	⋮	⋮	⋮	⋮	⋮	⋮	⋮	⋮	⋮	⋮	⋮	⋮	⋮	⋮	⋮	⋮	⋮
127	-0.99218	-1.0160	0	0	1	1	1	1	1	1	1	1	1	1	0	1	1	0	0	0	0	0	0	0	0	0	0
128	-1.00000	-1.0240	0	0	1	1	1	1	1	1	1	1	1	1	0	1	1	0	0	0	0	0	0	0	0	0	0
129	-1.00781	-1.0320	0	1	0	0	0	0	0	0	0	0	0	0	1	0	1	1	1	1	1	1	1	1	1	1	1
⋮	⋮	⋮	⋮	⋮	⋮	⋮	⋮	⋮	⋮	⋮	⋮	⋮	⋮	⋮	⋮	⋮	⋮	⋮	⋮	⋮	⋮	⋮	⋮	⋮	⋮	⋮	⋮
255	-1.99218	-2.0400	0	1	1	1	1	1	1	1	1	1	1	1	1	0	0	0	0	0	0	0	0	0	0	0	0
256	-2.00000	-2.0480	1	1	1	1	1	1	1	1	1	1	1	1	1	0	0	0	0	0	0	0	0	0	0	0	0

■ External Connection Diagram

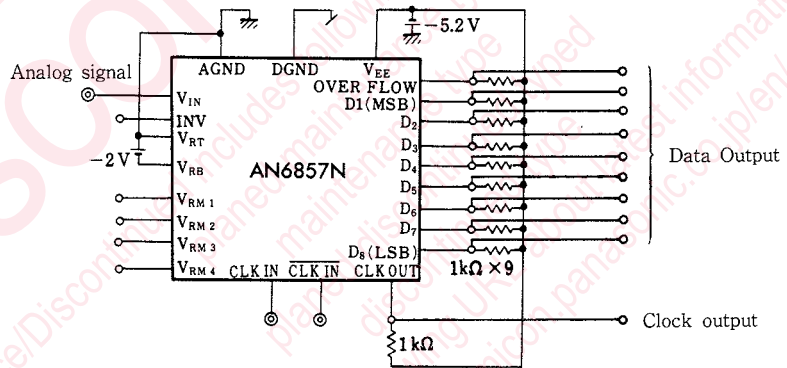

Request for your special attention and precautions in using the technical information and semiconductors described in this book

- (1) If any of the products or technical information described in this book is to be exported or provided to non-residents, the laws and regulations of the exporting country, especially, those with regard to security export control, must be observed.
- (2) The technical information described in this book is intended only to show the main characteristics and application circuit examples of the products. No license is granted in and to any intellectual property right or other right owned by Panasonic Corporation or any other company. Therefore, no responsibility is assumed by our company as to the infringement upon any such right owned by any other company which may arise as a result of the use of technical information described in this book.
- (3) The products described in this book are intended to be used for standard applications or general electronic equipment (such as office equipment, communications equipment, measuring instruments and household appliances).
Consult our sales staff in advance for information on the following applications:
 - Special applications (such as for airplanes, aerospace, automobiles, traffic control equipment, combustion equipment, life support systems and safety devices) in which exceptional quality and reliability are required, or if the failure or malfunction of the products may directly jeopardize life or harm the human body.
 - Any applications other than the standard applications intended.
- (4) The products and product specifications described in this book are subject to change without notice for modification and/or improvement. At the final stage of your design, purchasing, or use of the products, therefore, ask for the most up-to-date Product Standards in advance to make sure that the latest specifications satisfy your requirements.
- (5) When designing your equipment, comply with the range of absolute maximum rating and the guaranteed operating conditions (operating power supply voltage and operating environment etc.). Especially, please be careful not to exceed the range of absolute maximum rating on the transient state, such as power-on, power-off and mode-switching. Otherwise, we will not be liable for any defect which may arise later in your equipment.
 - Even when the products are used within the guaranteed values, take into the consideration of incidence of break down and failure mode, possible to occur to semiconductor products. Measures on the systems such as redundant design, arresting the spread of fire or preventing glitch are recommended in order to prevent physical injury, fire, social damages, for example, by using the products.
- (6) Comply with the instructions for use in order to prevent breakdown and characteristics change due to external factors (ESD, EOS, thermal stress and mechanical stress) at the time of handling, mounting or at customer's process. When using products for which damp-proof packing is required, satisfy the conditions, such as shelf life and the elapsed time since first opening the packages.
- (7) This book may be not reprinted or reproduced whether wholly or partially, without the prior written permission of our company.



LittleDiode supplies new, hard to find or obsolete electronic components and semiconductors all over the world.

With over two million different components listed you are sure to find the part you need.

Feel free to visit us today at our online store:

LittleDiode.com

Looking forward to providing you with the best possible service.