

L3235 WITH EXTERNAL RINGING

by L. Vergani, W Rossi

This application note shows an easy way, adding few external components, to adapt the L3235 SLIC to operate together with electromechanical ringing relay and to perform RING/TRIP function.

INTRODUCTION

The SGS-THOMSON SLIC kit L3234/L3235 designed for PABX application and providing also the ringing generation function (L3234), can be easily used also in system where a standard ringing generator is already present and there are difficulties in providing the 100V positive supply for the L3234 ringing injector.

CIRCUIT IMPLEMENTATION

Here below you can find a detailed description of the RING TRIP circuitry behavior and its dimensioning.

For all other characteristics like DC, AC performance, voice path, control interface and other details, the application is the same as the L3234/L3235 KIT therefore please refer to the L3234/L3235 datasheet for more informations.

Figure 1.

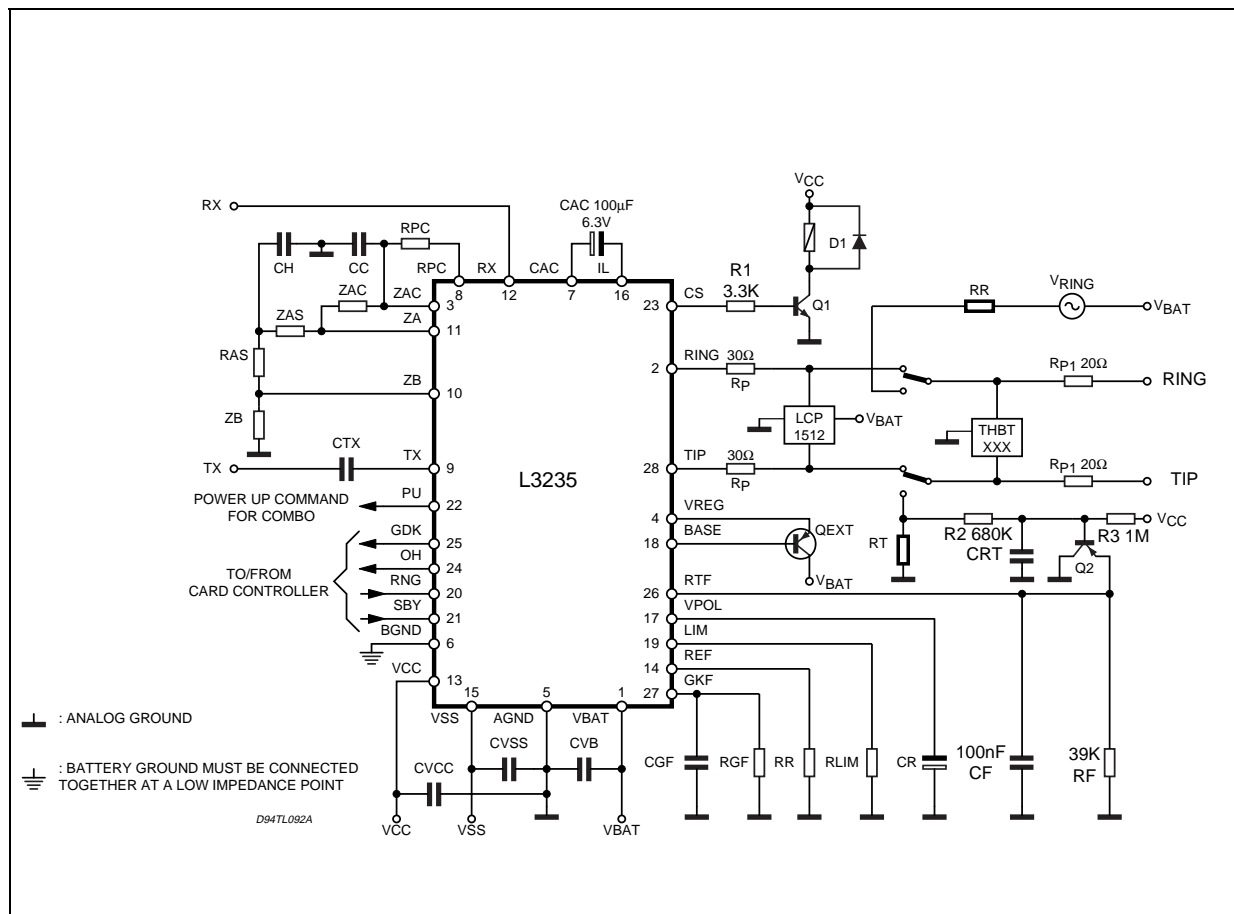

APPLICATION NOTE

The different operating modes of the L3235 can be programmed through the digital interface based on two input pins SBY and RNG.

When ringing mode is selected, through RNG and SBY control pins, the L3235 set CS pin to 1 activating, the relay, with 1mA base current into Q1 (max. CS current).

In this condition the relay is activated and the ringing signal is connected to the line through RR and terminated to GND by RT resistor.

Dimensioning opportunely the resistors R2 and R3 and the capacitor CRT, connected to the base of the transistor Q2, it is possible to fix a DC level that will keep the transistor T2 in OFF condition when no DC current is flowing into the line (telephone in ON-HOOK condition).

When the phone goes OFF-HOOK the negative voltage across ringing resistor force rapidly in conduction the transistor connected to the RTF pin, producing an OFF-HOOK DETECTION.

Once OFF-HOOK is detected, the CS pin is automatically driven low by L3235, disconnecting the ring relay and therefore performing an AUTO RING TRIP function.

The key component for good Ring Trip performances is the CRT capacitor.

It must have a proper value to reduce the ringing signal that appears on the resistor RT and therefore on the base of Q2.

In particular it is important to avoid that the ripple on the Q2 base produces an false Ring Trip detection when an high ringing signal is used (90Vrms) and five phone are connected in parallel (5REN) with 0Ω line resistor and in particular when the value of RR and RT is 400Ω (2X400).

These are the worst condition that can produce an high ripple level on Q2 base, this effect can be prevented choosing an high value CRT.

At the same time this capacitor can't have a too high value otherwise the Ring Trip Detection Time will be too long in particular for long loops.

In this application the CRT capacitor has been optimized in order to keep the Ring Trip Time always lower than 100ms even with line resistor greater than 2KΩ.

The components value shown in fig.1 have been chosen in order to obtain the best compromise with the constraints above explained.

In the table below it is possible to observe the minimum value that the capacitor CRT must assume versus frequency for different RR/RT resistor and VRING up to 90Vrms.

	16Hz	25Hz	40Hz	50Hz	68Hz	RR/RT
CRT≥	270nF	220nF	170nF	150nF	150nF	2x400
CRT≥	150nF	150nF	120nF	100nF	82nF	2x200

Information furnished is believed to be accurate and reliable. However, SGS-THOMSON Microelectronics assumes no responsibility for the consequences of use of such information nor for any infringement of patents or other rights of third parties which may result from its use. No license is granted by implication or otherwise under any patent or patent rights of SGS-THOMSON Microelectronics. Specifications mentioned in this publication are subject to change without notice. This publication supersedes and replaces all information previously supplied. SGS-THOMSON Microelectronics products are not authorized for use as critical components in life support devices or systems without express written approval of SGS-THOMSON Microelectronics.

© 1995 SGS-THOMSON Microelectronics - All Rights Reserved

SGS-THOMSON Microelectronics GROUP OF COMPANIES

Australia - Brazil - France - Germany - Hong Kong - Italy - Japan - Korea - Malaysia - Malta - Morocco - The Netherlands - Singapore - Spain - Sweden - Switzerland - Taiwan - Thailand - United Kingdom - U.S.A.



LittleDiode supplies new, hard to find or obsolete electronic components and semiconductors all over the world.

With over two million different components listed you are sure to find the part you need.

Feel free to visit us today at our online store:

LittleDiode.com

Looking forward to providing you with the best possible service.