

## Reducing Current Consumption at 32kHz with ST62

C. PILON, L. PERIER

### INTRODUCTION

In many cases a 32kHz crystal is chosen for the oscillator of the ST62 microcontroller in order to achieve the minimum current consumption in the application.

This note provides a technique for minimising the current consumption when using a crystal oscillator at this frequency.

The note should be read in conjunction with Application Note AN670 - Oscillator Selection for the ST62.

### 1 CIRCUIT MODIFICATION

A standard oscillator circuit is shown in Figure 1. This circuit is suitable for higher frequency oscillations up to the maximum oscillation frequency of the ST62.

The current consumption of the oscillator of the ST62 can be reduced effectively when a resistor is added in the circuit as shown in Figure 2.

Figure 1. Standard Circuit.

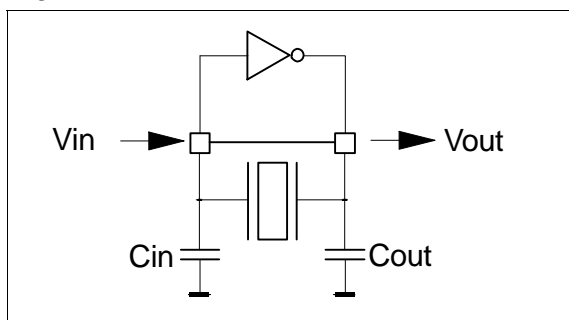
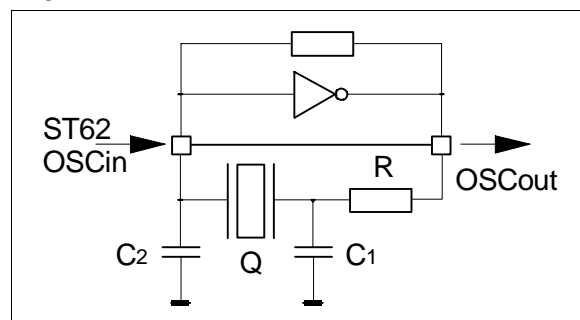

Figure 2. Modified Circuit.



The Resistor (R) limits the power dissipation through the crystal, resulting in a lower load for the inverter circuit and a minimum power consumption.

Note that the resistor adds a phase shift to the Capacitor and oscillator network. This shift must not be excessive such that it affects the loop functionality.

Recommended values are:

R = 330K

C1 = 33 pF

C2 = 33 pF

Q = 32.8kHz crystal

## 2 RESULTS

The current consumption in WAIT mode measures the oscillator consumption as long as there is no additional consumption in the I/O pins with their associated external circuits.

The following table indicates the typical potential current saving in the WAIT mode of the ST62E2x microcontroller at a temperature of 25 C.

*Typical current saving (32kHz crystal)*

	<b>Standard oscillator</b>	<b>Modified oscillator</b>
<b>5V</b>	900 $\mu$ A	450 $\mu$ A
<b>3V</b>	50 $\mu$ A	35 $\mu$ A

The oscillator start-up time is also increased and ranges from 300 to 500 ms. This is due to the R, C1 time constant and the normal start-up time of the 32kHz crystal (typically around 250ms).

The use of this additional resistor is made possible by the high gain of the inverter in the ST62 oscillator circuit when working at 32kHz and the characteristics of a standard 32kHz crystal

Information furnished is believed to be accurate and reliable. However, SGS-THOMSON Microelectronics assumes no responsibility for the consequences of use of such information nor for any infringement of patents or other rights of third parties which may result from its use. No license is granted by implication or otherwise under any patent or patent rights of SGS-THOMSON Microelectronics. Specifications mentioned in this publication are subject to change without notice. This publication supersedes and replaces all information previously supplied. SGS-THOMSON Microelectronics products are not authorized for use as critical components in life support devices or systems without the express written approval of SGS-THOMSON Microelectronics.

© 1994 SGS-THOMSON Microelectronics - All Rights Reserved

Purchase of I<sup>2</sup>C Components by SGS-THOMSON Microelectronics, conveys a license under the Philips I<sup>2</sup>C Patent. Rights to use these components in an I<sup>2</sup>C system, is granted provided that the system conforms to the I<sup>2</sup>C Standard Specifications as defined by Philips.

SGS-THOMSON Microelectronics GROUP OF COMPANIES

Australia - Brazil - France - Germany - Hong Kong - Italy - Japan - Korea - Malaysia - Malta - Morocco  
The Netherlands - Singapore - Spain - Sweden - Switzerland - Taiwan - Thailand - United Kingdom -  
U.S.A.



LittleDiode supplies new, hard to find or obsolete electronic components and semiconductors all over the world.

With over two million different components listed you are sure to find the part you need.

Feel free to visit us today at our online store:

[LittleDiode.com](http://LittleDiode.com)

Looking forward to providing you with the best possible service.