

# AN6718N

## Microwave Oven Inverter Control IC

### Overview

The AN6718N is an IC for resonance type inverter control of microwave oven. It can directly control the IGBT (Insulated Gate Bipolar Transistor) and incorporates the various protective functions.

### Features

- Resonance type inverter control by synchronous oscillator and pulse width modulator
- Shunt regulator built-in the power supply block
- Soft start function built-in
- Abnormality detection function built-in
- Output circuit directly driving the IGBT

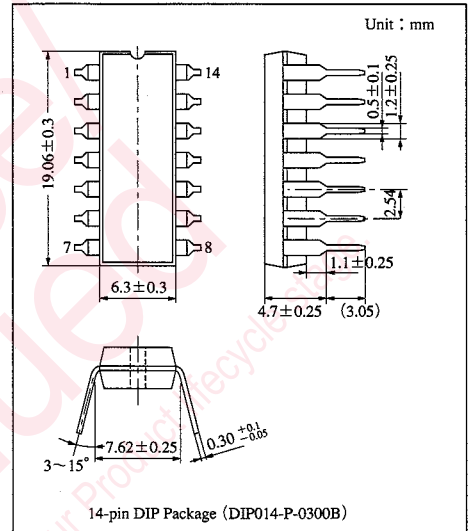

### Block Diagram

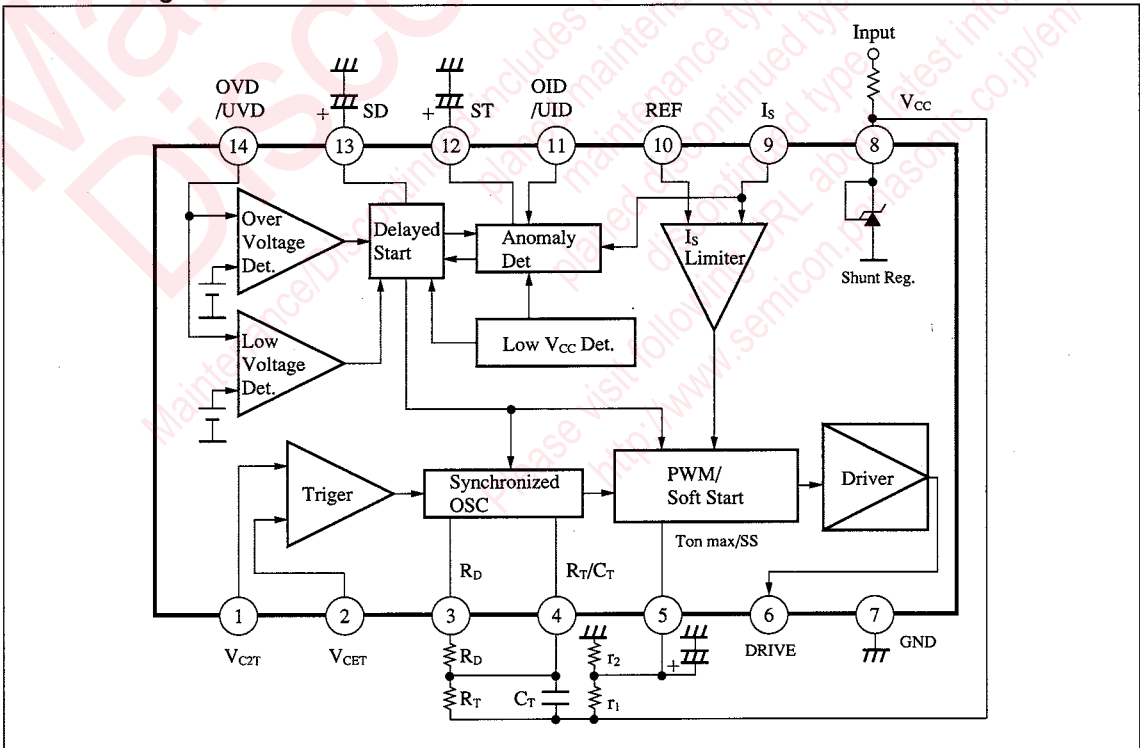

Others

### ■ Absolute Maximum Rating (Ta=25°C)

Parameter	Symbol	Rating	Unit
Supply voltage <sup>Note 1)</sup>	V <sub>CC</sub>	—	V
Supply current	I <sub>CC</sub>	40	mA
Power dissipation	P <sub>D</sub>	430 (Ta=85°C)	mW
Operating ambient temperature	T <sub>opr</sub>	-20 to +85	°C
Storage temperature	T <sub>stg</sub>	-55 to +150	°C

Note 1) The supply voltage value is limited by shunt regulator.

Note 2) Do not use the load larger than 8200 pF for the pulse output terminal.

### ■ Electrical Characteristics (Ta=25±2°C)

Parameter	Symbol	Condition	min	typ	max	Unit
Supply voltage	V <sub>CC</sub>		13.1	14.1	15.1	V
Supply current	I <sub>CC</sub>		21.5	29.0	36.8	mA
Constant current source (1)	I <sub>13</sub>		-280	-195	-125	μA
Constant current source (2)	I <sub>12</sub> <sup>H</sup>		-405	-280	-180	μA
Constant current source (3)	I <sub>12</sub> <sup>L</sup>		-12.0	-8.3	-5.4	μA
Low voltage detection threshold	V <sub>14-7</sub> (1)	Set it with Pin ⑭ detection condition.	3.4	4.2	5.0	V
Overvoltage detection threshold	V <sub>14-7</sub> (2)	Set it with Pin ⑭ detection condition.	5.8	7.3	8.7	V
Power control operation	V <sub>9-7</sub>	Set it with Pin ⑨ detection condition.	5.5	6.0	6.5	V
Low V <sub>CC</sub> detection threshold	V <sub>8-7</sub>	Set it with Pin ⑧ detection condition.	7.7	9.1	10.5	V
Abnormality voltage detection threshold (1)	V <sub>9-7</sub> <sup>H</sup>	Set it with Pin ⑨ detection condition.	8.9	9.3	9.7	V
Abnormality voltage detection threshold (2)	V <sub>9-7</sub> <sup>L</sup>	Set it with Pin ⑨ detection condition.	5.7	6.2	6.7	V
PWM circuit minimum pulse width	T <sub>6-M</sub>	V <sub>B</sub> =20V	1.35	1.9	2.45	μs
PWM circuit central pulse duty	D <sub>6-C</sub>	V <sub>B</sub> =20V	25.5	32.0	38.5	%
Oscillation circuit self-excitation cycle	T <sub>6</sub>	V <sub>B</sub> =20V	54	68	82	μs
Trigger circuit delay time	T <sub>D2-6</sub>	V <sub>B</sub> =20V	3.6	4.5	5.4	μs
Safety timer operation time (1)	T <sub>12</sub> (1)	V <sub>B</sub> =13.1V	5.0	9.0	13.0	ms
Safety timer operation time (2)	T <sub>12</sub> (2)	V <sub>B</sub> =13.1V	0.65	1.2	1.75	ms
Maximum output voltage (1)	V <sub>6-7</sub>		—	110	200	mV
Maximum output voltage (2)	V <sub>8-7</sub>		0.8	1.2	1.6	V
Source current peak value	I <sub>r</sub>	V <sub>B</sub> =20V	0.1	0.45	—	A
Sink current peak value	I <sub>f</sub>	V <sub>B</sub> =20V	0.2	0.55	—	A
Output pulse rise time	t <sub>r</sub>	V <sub>B</sub> =20V	0.1	0.2	0.4	μs
Output pulse fall time	t <sub>f</sub>	V <sub>B</sub> =20V	0.05	0.15	0.3	μs

■ Pin Name

Pin No.	Pin name	Pin No.	Pin name
1	Trigger input (A)	8	V <sub>CC</sub>
2	Trigger input (B)	9	IS limiter input
3	Oscillation circuit time constant (A) setting	10	Power control reference voltage
4	Oscillation circuit time constant (B) setting	11	Abnormality detection level setting
5	Pulse width maximum value and soft start time constant setting	12	Abnormality detection timer C
6	Pulse output	13	Start delay C
7	GND	14	Low voltage detection input and overvoltage detection input

■ Package Power Dissipation

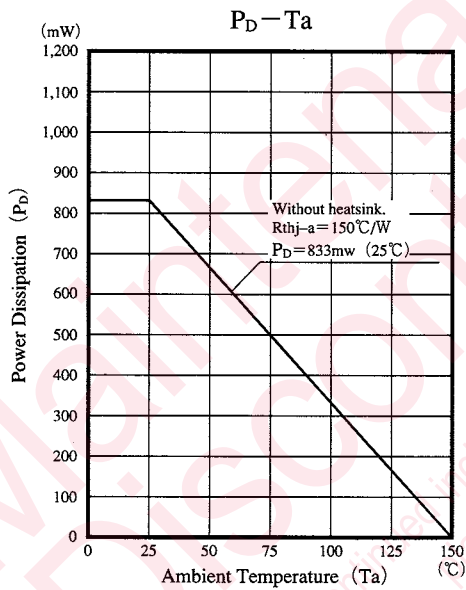

■ Application Circuit

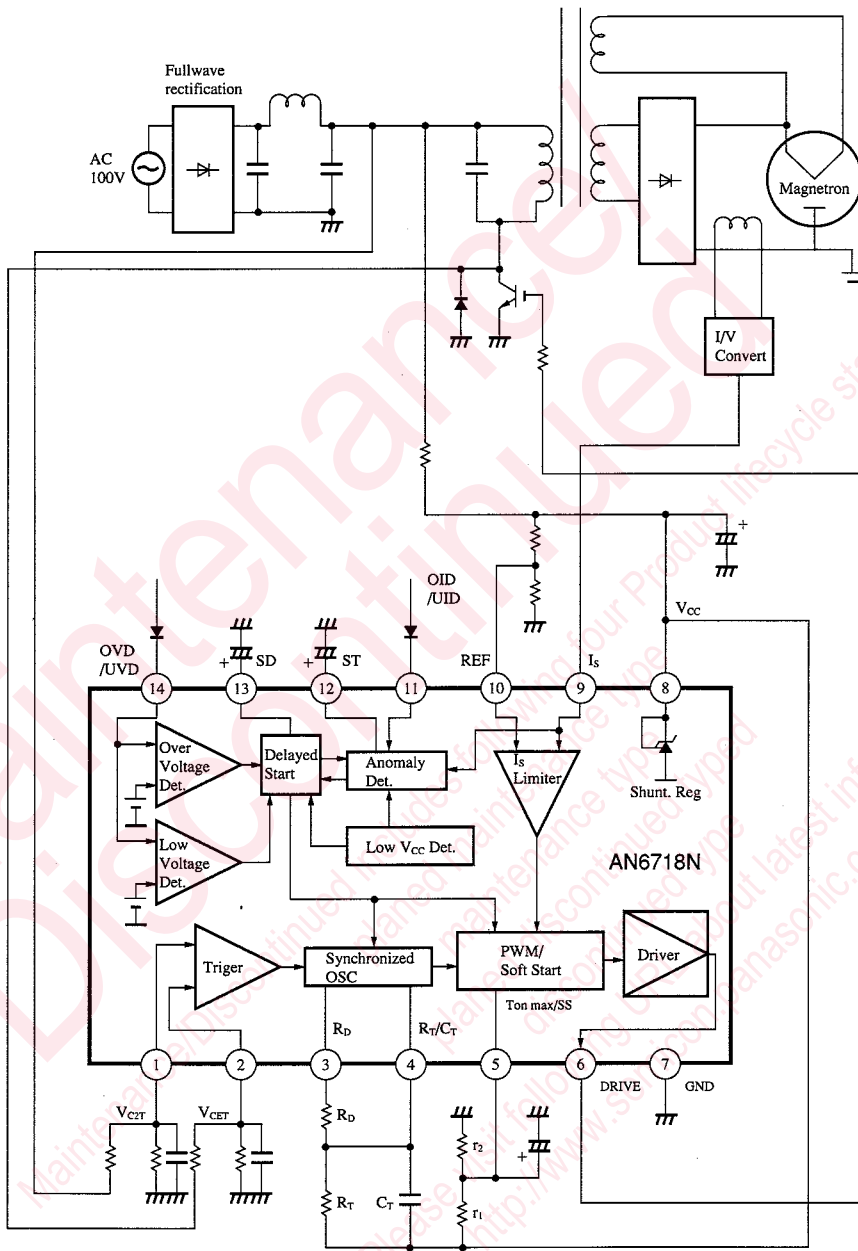

**Pin Descriptions**

Pin No.	Symbol	I/O	Pin description	Equivalent circuit
1	V <sub>CT2</sub>	I	<p>&lt;Trigger input&gt; It sets the pulse output drive to "Low" after delay time T<sub>D</sub> elapses from the voltage cross point where V<sub>CET</sub> &gt; V<sub>CT2</sub> is replaced with V<sub>CET</sub> &lt; V<sub>CT2</sub>.</p>	<p>140V full-wave rectification</p>
2	V <sub>CET</sub>	I		
3	R <sub>D</sub>	O	<p>&lt;Oscillation circuit time constant&gt; It determines the self-excitation oscillation cycle (maximum cycle) T<sub>O</sub> and delay time T<sub>D</sub>. T<sub>D</sub> ∝ R<sub>T</sub>C<sub>T</sub> T<sub>D</sub> ∝ (R<sub>T</sub>/R<sub>D</sub>)C<sub>T</sub></p>	
4	R <sub>T</sub> /C <sub>T</sub>	I	<p>&lt;Pulse width maximum value and soft start time constant&gt; It determines the pulse width maximum value and the soft start time. The pulse width maximum value is determined by R<sub>T</sub>C<sub>T</sub>, the voltage dividing ratio between R<sub>1</sub> and R<sub>2</sub>. Soft start time is proportional to (R<sub>1</sub>/R<sub>2</sub>)C<sub>SS</sub></p>	
5	T <sub>ONmax/ss</sub>	I		
6	DRIVE	O	<p>&lt;Pulse output&gt; It controls the gate signal of the inverter controlled IGBT.</p>	
7	GND	I	<p>&lt;Ground terminal&gt;</p>	
8	V <sub>CC</sub>	I	<p>&lt;Power supply terminal&gt; The shunt regulator of 14V output is built in.</p>	

Others

Pin Descriptions (cont.)

Pin No.	Symbol	I/O	Pin description	Equivalent circuit
9	I <sub>s</sub>	I	<p>&lt;I<sub>s</sub> limiter&gt; &lt;Abnormality detection&gt;                      It controls the pulse width of pulse output drive so that the I<sub>s</sub> voltage could be equal to REF voltage. It stops the inverter when the I<sub>s</sub> voltage deviates from the range of OID/UID voltage +2V<sub>D</sub>/-3V<sub>D</sub>.                      (It is not automatically reset. It is reset by restart of power supply or low V<sub>CC</sub> detection circuit.)</p>	
10	REF	I		
11	OID/UID	O		
12	ST	I	<p>&lt;Abnormality detection timer C&gt;                      It determines the delay time from the time when the I<sub>s</sub> voltage decreases under the OID/UID voltage - 3V<sub>D</sub> to the time when the inverter stops,  <math>T_{OID} \propto C_{ST}/I_1</math>                      It determines the delay time from the time when the I<sub>s</sub> voltage increases over the OID/UID voltage +2V<sub>D</sub> to the time when the inverter stops,  <math>T_{UID} \propto C_{ST}/I_1 + I_2</math></p>	
13	SD	I	<p>&lt;C for start delay&gt;                      It determines the start delay time,  <math>T_{SD} \propto C_{SP}</math></p>	
14	OVD/UVD	I	<p>&lt;Low voltage detection input and overvoltage detection input&gt;                      It stops the inverter when the OVD/UVD voltage becomes smaller than the V<sub>OVD</sub> or when it becomes larger than the V<sub>UVD</sub>.</p>	

## Request for your special attention and precautions in using the technical information and semiconductors described in this book

- (1) If any of the products or technical information described in this book is to be exported or provided to non-residents, the laws and regulations of the exporting country, especially, those with regard to security export control, must be observed.
- (2) The technical information described in this book is intended only to show the main characteristics and application circuit examples of the products. No license is granted in and to any intellectual property right or other right owned by Panasonic Corporation or any other company. Therefore, no responsibility is assumed by our company as to the infringement upon any such right owned by any other company which may arise as a result of the use of technical information described in this book.
- (3) The products described in this book are intended to be used for standard applications or general electronic equipment (such as office equipment, communications equipment, measuring instruments and household appliances).  
Consult our sales staff in advance for information on the following applications:
  - Special applications (such as for airplanes, aerospace, automobiles, traffic control equipment, combustion equipment, life support systems and safety devices) in which exceptional quality and reliability are required, or if the failure or malfunction of the products may directly jeopardize life or harm the human body.
  - Any applications other than the standard applications intended.
- (4) The products and product specifications described in this book are subject to change without notice for modification and/or improvement. At the final stage of your design, purchasing, or use of the products, therefore, ask for the most up-to-date Product Standards in advance to make sure that the latest specifications satisfy your requirements.
- (5) When designing your equipment, comply with the range of absolute maximum rating and the guaranteed operating conditions (operating power supply voltage and operating environment etc.). Especially, please be careful not to exceed the range of absolute maximum rating on the transient state, such as power-on, power-off and mode-switching. Otherwise, we will not be liable for any defect which may arise later in your equipment.
  - Even when the products are used within the guaranteed values, take into the consideration of incidence of break down and failure mode, possible to occur to semiconductor products. Measures on the systems such as redundant design, arresting the spread of fire or preventing glitch are recommended in order to prevent physical injury, fire, social damages, for example, by using the products.
- (6) Comply with the instructions for use in order to prevent breakdown and characteristics change due to external factors (ESD, EOS, thermal stress and mechanical stress) at the time of handling, mounting or at customer's process. When using products for which damp-proof packing is required, satisfy the conditions, such as shelf life and the elapsed time since first opening the packages.
- (7) This book may be not reprinted or reproduced whether wholly or partially, without the prior written permission of our company.



LittleDiode supplies new, hard to find or obsolete electronic components and semiconductors all over the world.

With over two million different components listed you are sure to find the part you need.

Feel free to visit us today at our online store:

**[LittleDiode.com](http://LittleDiode.com)**

Looking forward to providing you with the best possible service.