

Oscillator Selection for ST62

C. PILON, L. PERIER

INTRODUCTION

The purpose of this note is to give indications on how to choose a resonator or a quartz crystal in order to achieve reliable oscillation with the ST62 Microcontroller. This document provides first the major resonator parameters useful for a design. It then proposes measurement methods to ensure a safe oscillation.

1 OSCILLATION FREQUENCY

The resonator can be modelised by a serial/parallel oscillator circuit as described in Figure 1.

The additional capacitances C_{ext} are usually connected to the oscillator pins in order to define a stable oscillating frequency. The value of these capacitances is usually given by the manufacturer of the resonator.

The oscillation frequency is the resonant frequency of the equivalent circuit given in Figure 2. The resonator is inductive in the oscillation frequency range.

Figure 1. Resonator model.

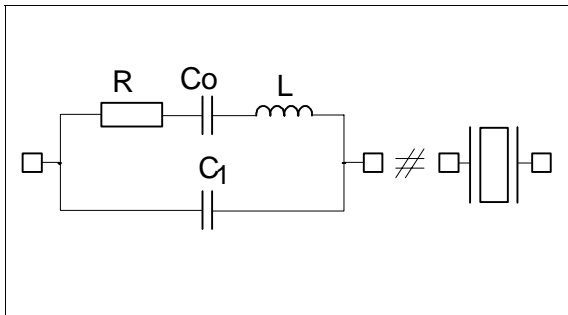
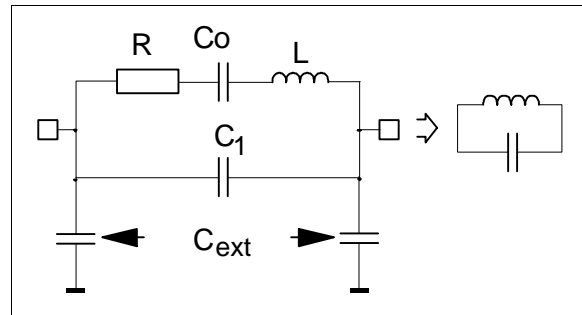

Figure 2. Equivalent circuit.



2 OSCILLATION CONDITIONS

The proposed method is based on the Barkhausen criteria. This leads to a safe result providing that the oscillator fulfills these criteria. Three points have to be analysed: oscillator start-up, frequency stability and the start-up time.

2.1 The Barkhausen criteria:

An oscillator can be modeled as defined Figure 3. B is the resonator gain and G the amplifier/inverter gain. The value of $B \times G$ defines the oscillator behaviour:

- $B \times G \gg 1$: square waveform, start-up OK
- $B \times G > 1$: waveform with harmonic distortion, start-up OK
- $B \times G = 1$: sine waveform, start-up critical
- $B \times G < 1$: no oscillation

Figure 3: Oscillator model

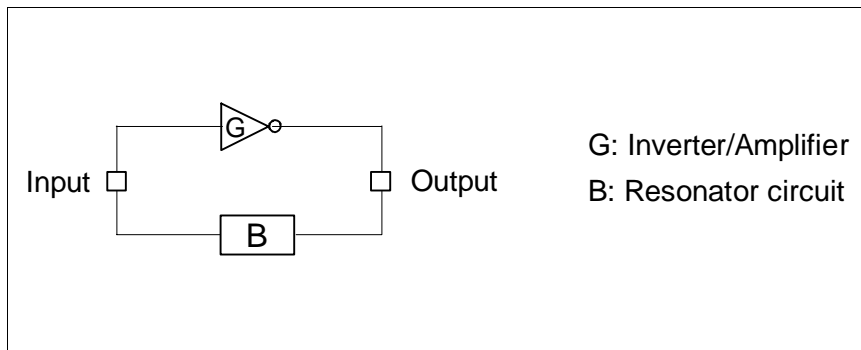

2.2 Start-up

The oscillator can start if the gain $B \times G$ is above 1. The amplifier gain must compensate for the resonator circuit attenuation and provide a sufficient gain margin ($>3\text{dB}$).

In addition, the resonator circuit B must introduce a 180° phase delay if the G amplifier is an inverter and no rotation if it is a non inverting amplifier.

With classical circuits such as a Pierce type oscillator (Figure 4), the 180° phase rotation is due to capacitances (C_{out} and C_{in}).

Figure 4. Pierce type oscillator.

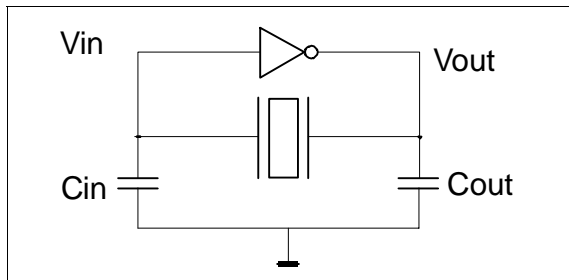
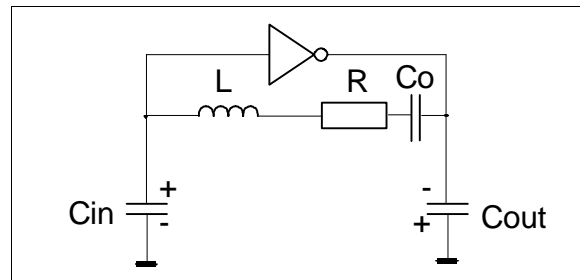

Figure 5. Equivalent schematic at the resonant frequency



At the resonance frequency (serial mode), the circuit can be modeled as described in Figure 5. The resonator voltage is balanced between the two capacitances. So the phase of the voltages V_{in} and V_{out} is delayed by 180° . Depending on the capacitance values, V_{in} is either higher ($C_{\text{out}} > C_{\text{in}}$), smaller ($C_{\text{out}} < C_{\text{in}}$) or equal to V_{out} .

The trade offs in the choice of C_{in} and C_{out} are:

- $C_{\text{out}} = C_{\text{in}} : V_{\text{in}} = V_{\text{out}}$

This is the typical case and is to be used as often as possible.

- $C_{\text{out}} > C_{\text{in}} : V_{\text{in}} > V_{\text{out}}$

The loop gain is increased but there is a risk that the oscillation occurs at a harmonic of the resonator frequency.

- $C_{\text{out}} < C_{\text{in}} : V_{\text{in}} < V_{\text{out}}$

The output voltage is increased. The risk of oscillation at a harmonic of the resonator frequency is low. V_{in} must be high enough to satisfy the condition $B \times G > 1$.

2.3 Measurement of the loop gain (open loop)

The measurement is based on the schematic shown in Figure 6. The method is the following:

- Open the loop as described in Figure 6.
- Place an oscillator probe on points 1 and 2. Note that the real C value for the calculation is $C_{\text{probe}} + C_{\text{in}}$.
- Inject a voltage S with a signal generator. This signal must be adjusted in frequency to maximize the voltage V_2 .
- Adjust S to a value small enough to avoid saturation of the amplifier (around 200mV on V_1).
- Calculate the ratio V_1/V_2 . This value has to be between +3 and +10dB (1.5 to 3).

If the ratio is above +3dB, the oscillator start is safe. If it is below, C_{in} should be decreased.

Figure 6. Gain loop measurement schematic.

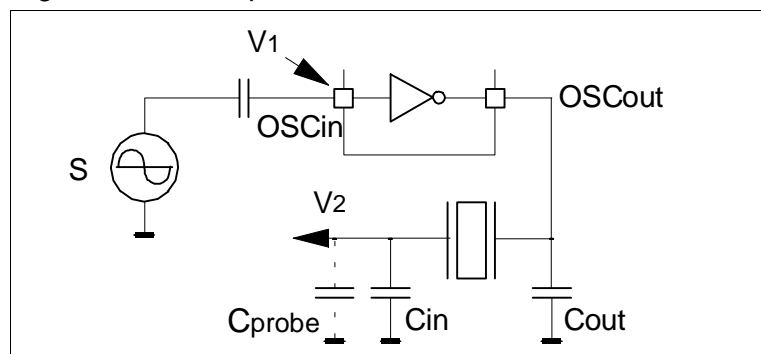

2.4 Frequency stability

The stability is first defined by the resonator characteristics. Nevertheless, if the open loop gain exceeds +10dB, the oscillation could occur on a harmonic of the resonator frequency. In such cases, the value of C_{in} should be increased to reduce the loop gain or a filter rejecting this harmonic must be added.

2.5 Start-up time

The start-up time depends on the amplifier polarisation time and on the circuit transients. The polarisation of the amplifier can be accelerated by dividing the C_{in} capacitance in two as described in Figure 7.

Figure 7. Amplifier polarisation acceleration

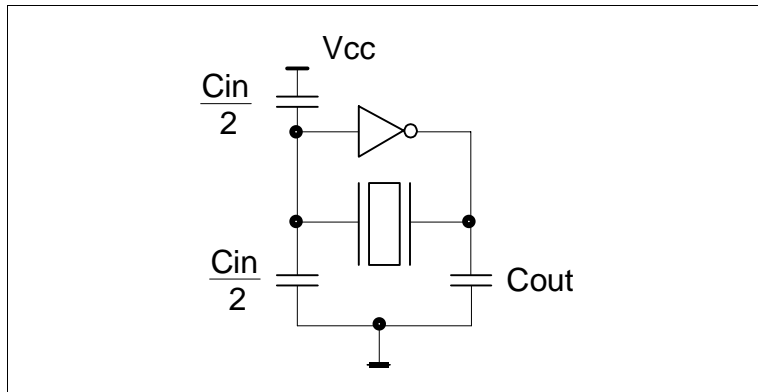

The start-up time is also longer when C_{in} and C_{out} are increased. As a result, for very low start-up time (i.e. low frequency quartz crystal), these capacitances values should be as small as possible. Generally, the higher the crystal Q factor and lower the crystal frequency, the longer the start-up time.

3 CONCLUSION

This note describes a method to choose oscillator network capacitances adapted to standard resonators and quartz crystals (i.e. $r_s < 60\text{ohms}$ and $\text{gain} > 500$). Since several network values can be chosen, the capacitances values should be minimized in order not to affect the resonance frequency and reduce the start-up time.

Appendix 1: Test of a CSA Murata crystal resonator with an ST6210

1. Choice of the network capacitances

Resonator equivalent values:

$$L = 385 \mu\text{H}$$

$$C_0 = 4.4 \text{ pF}$$

$$C_1 = 36.3 \text{ pF}$$

$$r_s = 8.7 \text{ ohm}$$

$$Q = 1134$$

The oscillation mode is the fundamental mode.

The recommended load capacitances for 4MHz oscillation frequency are $2 \times 30\text{pF}$.

The corresponding oscillation frequency as calculated from the formula given in Appendix 2 is 4.03MHz.

2. Pseudo closed loop measurement

In the worst case ($T_{\text{ambient}} \text{ max}$, $V_{\text{supply}} \text{ min}$) the gain $V_{\text{out}}/V_{\text{in}}$ is 4.8. So the safety margin is +13.6dB.

3. Start-up time

The start-up time is measured in closed loop. In the worst conditions ($T_{\text{ambient}} \text{ max}$, $V_{\text{supply}} \text{ min}$), it is less than 1ms.

4. Conclusion

The selected ceramic resonator matches with the ST6210 oscillator.

Appendix 2: Calculation of the resonant frequency of ceramic resonator

1. Equivalent circuit at the resonance frequency

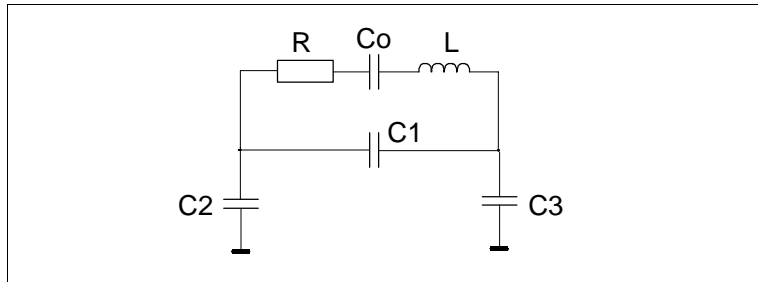

2. Transformation for simple calculation

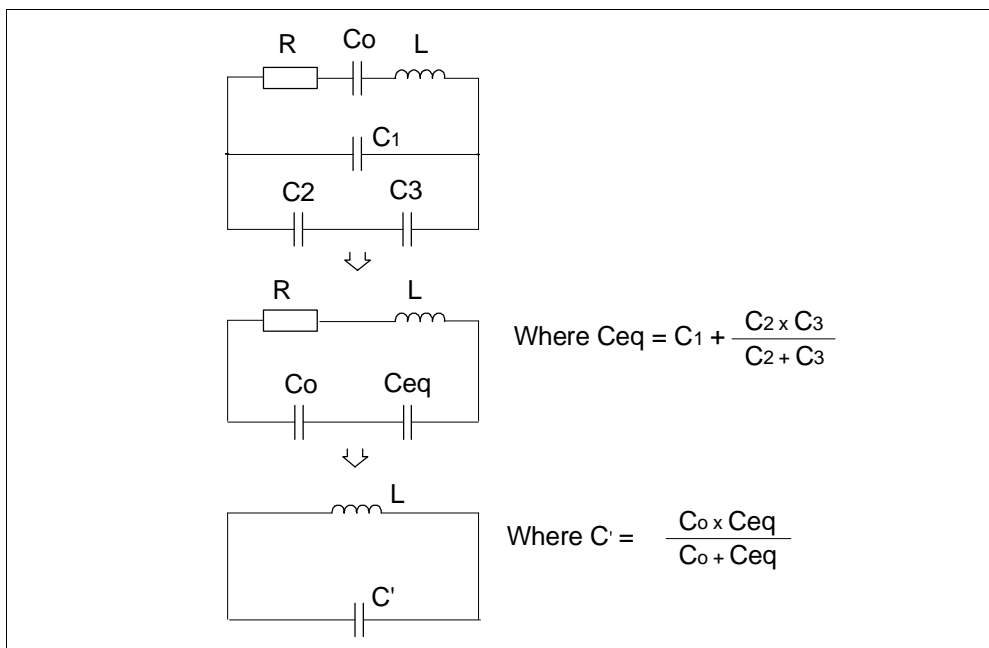

3. Resonant frequency

$$f = \frac{1}{2\pi\sqrt{L \times C'}}$$

4. Note

When using a ceramic resonator, the oscillation frequency is usually between the parallel and the series resonances. So both C_1 and C_o have to be included in the calculation. The resonance frequency of a crystal resonator is very near to the serial frequency. So only C_o has to be used for the frequency calculation.

NOTES:

Information furnished is believed to be accurate and reliable. However, SGS-THOMSON Microelectronics assumes no responsibility for the consequences of use of such information nor for any infringement of patents or other rights of third parties which may result from its use. No license is granted by implication or otherwise under any patent or patent rights of SGS-THOMSON Microelectronics. Specifications mentioned in this publication are subject to change without notice. This publication supersedes and replaces all information previously supplied. SGS-THOMSON Microelectronics products are not authorized for use as critical components in life support devices or systems without the express written approval of SGS-THOMSON Microelectronics.

© 1994 SGS-THOMSON Microelectronics - All Rights Reserved

Purchase of I²C Components by SGS-THOMSON Microelectronics, conveys a license under the Philips I²C Patent. Rights to use these components in an I²C system, is granted provided that the system conforms to the I²C Standard Specifications as defined by Philips.

SGS-THOMSON Microelectronics GROUP OF COMPANIES

Australia - Brazil - France - Germany - Hong Kong - Italy - Japan - Korea - Malaysia - Malta - Morocco
The Netherlands - Singapore - Spain - Sweden - Switzerland - Taiwan - Thailand - United Kingdom -
U.S.A.



LittleDiode supplies new, hard to find or obsolete electronic components and semiconductors all over the world.

With over two million different components listed you are sure to find the part you need.

Feel free to visit us today at our online store:

LittleDiode.com

Looking forward to providing you with the best possible service.