

AN6567, AN6568, AN6568S

Dual High Output Current Operational Amplifiers

Overview

The AN6567, the AN6568, and the AN6568S are high output current dual operational amplifiers which allows single power supply operation, realizing low current consumption, high slew rate and high output current.

Features

- Single supply operating
- High output current: $I_o=70\text{mA}$ min.
- Low supply current: $I_{cc}=5\text{mA}$ typ.
- High slew rate: $SR=1.0\text{V}/\mu\text{s}$ typ.
- Built-in input circuit protection
- Built-in phase compensation circuit

Block Diagram

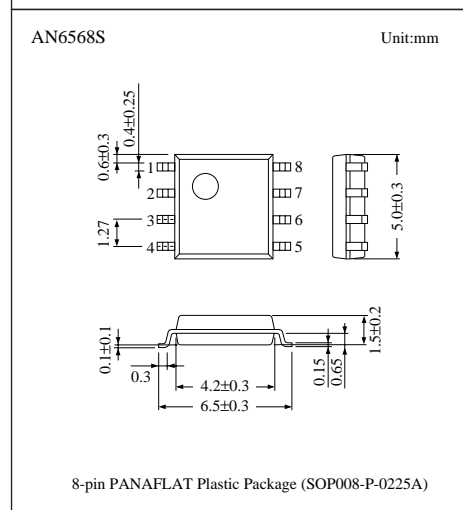
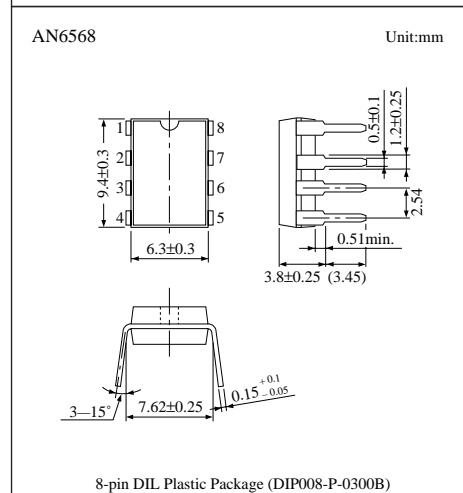
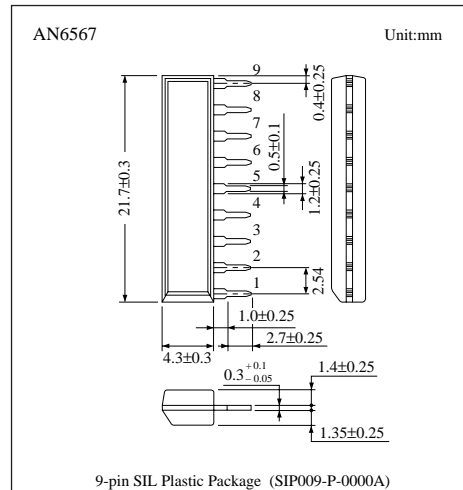
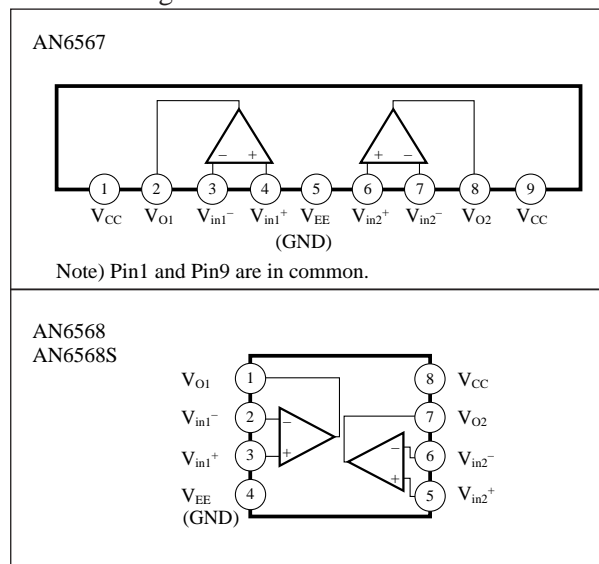

■ Pin Descriptions

〈AN6567〉

Pin No.	Pin name
1	V _{CC}
2	Ch.1 output
3	Ch.1 inverting input
4	Ch.1 non inverting input
5	V _{EE} (GND)
6	Ch.2 non inverting input
7	Ch.2 inverting input
8	Ch.2 output
9	V _{CC}

〈AN6568, AN6568S〉

Pin No.	Pin name
1	Ch.1 output
2	Ch.1 inverting input
3	Ch.1 non inverting input
4	V _{EE} (GND)
5	Ch.2 non inverting input
6	Ch.2 inverting input
7	Ch.2 output
8	V _{CC}

■ Absolute Maximum Ratings (Ta=25°C)

Parameter		Symbol	Rating	Unit
Voltage	Supply voltage	V _{CC}	18 (±9)	V
	Differential input voltage	V _{ID}	18	V
	Common-mode input voltage	V _{ICM}	-0.3 to +18	V
Power dissipation	AN6567, AN6568	P _D	500	mW
	AN6568S		360	
Operating ambient temperature		T _{opr}	-20 to +75	°C
Storage temperature	AN6567, AN6568	T _{stg}	-55 to +150	°C
	AN6568S		-55 to +125	

■ Electrical Characteristics (V_{CC}=15V, Ta=25°C)

Parameter	Symbol	Condition	min	typ	max	Unit
Input offset voltage	V _{I (offset)}	R _S ≤ 50Ω	—	2	5	mV
Input offset current	I _{IO}	R _S ≤ 50Ω	—	30	100	nA
Input bias current	I _{Bias}	R _S ≤ 50Ω	—	100	500	nA
Voltage gain	G _V	R _L = 2kΩ	88	100	—	dB
Maximum output voltage I	V _{O (max.)}	R _L ≥ 2kΩ, V _{CC} = 5V	3.3	—	—	V
Maximum output voltage II	V _{O (max.)}	I _O = 70mA, V _{CC} = 5V	3.0	—	—	V
Common-mode input voltage width	V _{CM}		V _{CC} - 2	—	—	V
Common-mode rejection ratio	CMR		80	90	—	dB
Supply voltage rejection ratio	SVR		80	90	—	dB
Supply current	I _{CC}	R _L = ∞, V _{CC} = 8.3V	—	5	—	mA
Slew rate	SR	R _L ≥ 2kΩ, A _V = 1	—	1.0	—	V/μs
Zero-cross frequency	f _(T)		—	1.3	—	MHz

■ Characteristics Curve

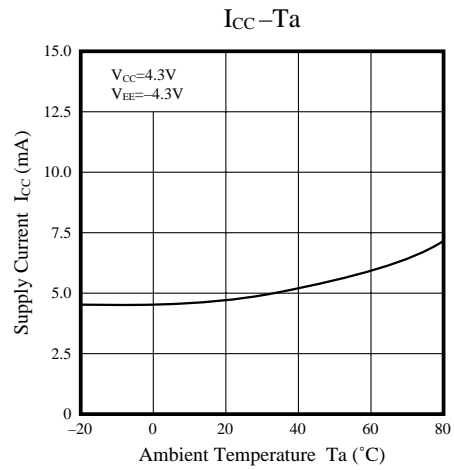
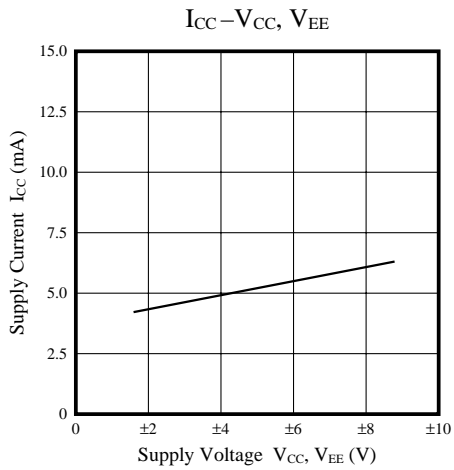
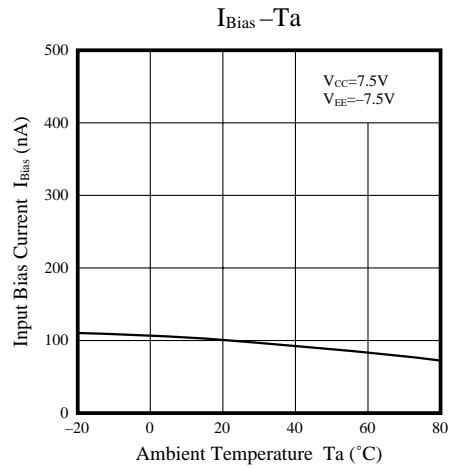
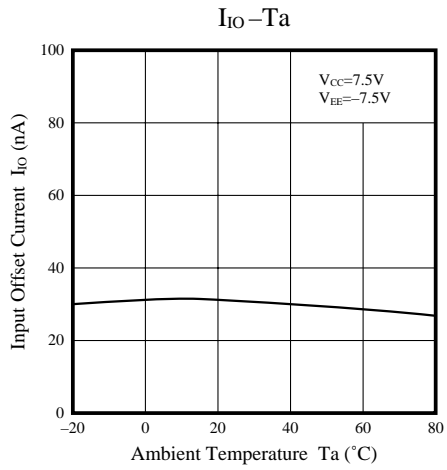
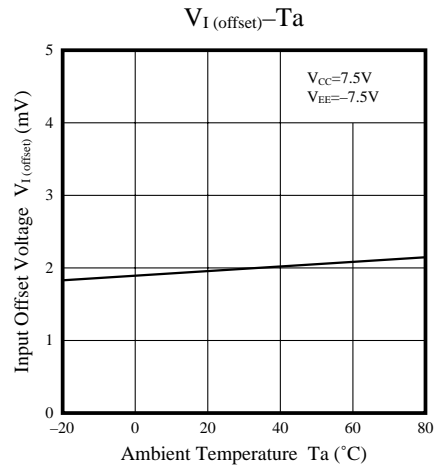
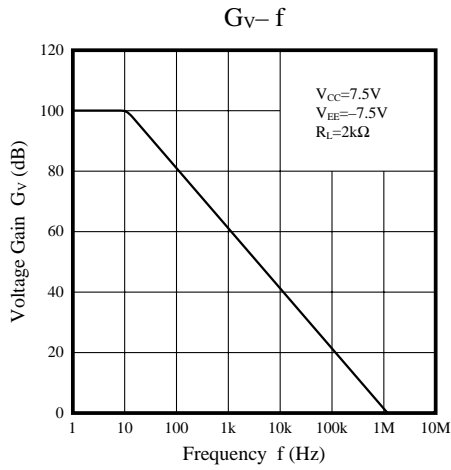

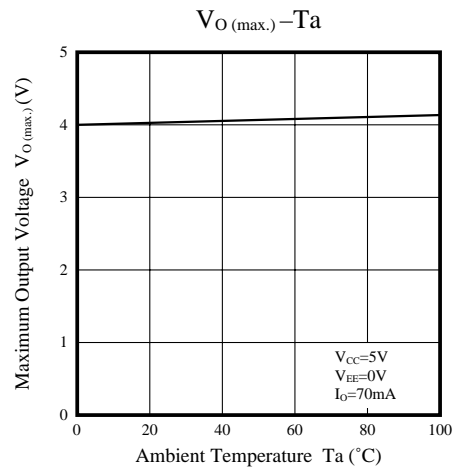
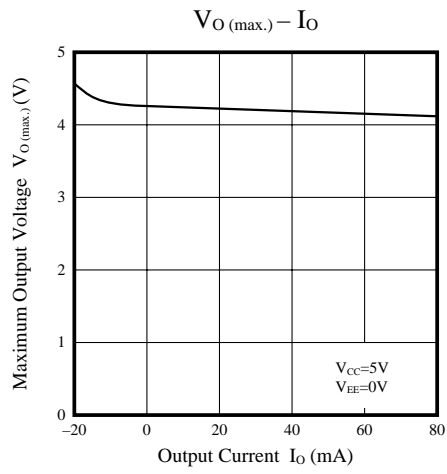



LittleDiode supplies new, hard to find or obsolete electronic components and semiconductors all over the world.

With over two million different components listed you are sure to find the part you need.

Feel free to visit us today at our online store:

LittleDiode.com

Looking forward to providing you with the best possible service.