

AN6553

Dual Operational Amplifiers

■ Overview

The AN6553 is a dual operational amplifier with phase compensation circuits built-in.

It is suitable for application to various electronic circuits such as active filters audio pre-amplifiers.

■ Features

- Phase compensation circuit built-in
- High gain, low noise
- Output short-circuit protection
- Slew rate: 2.0V/μs typ.

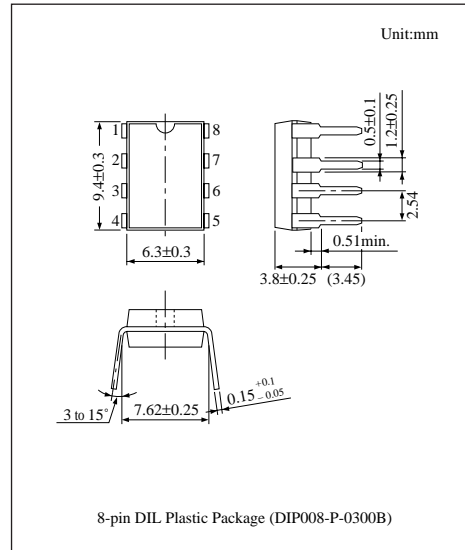

■ Block Diagram

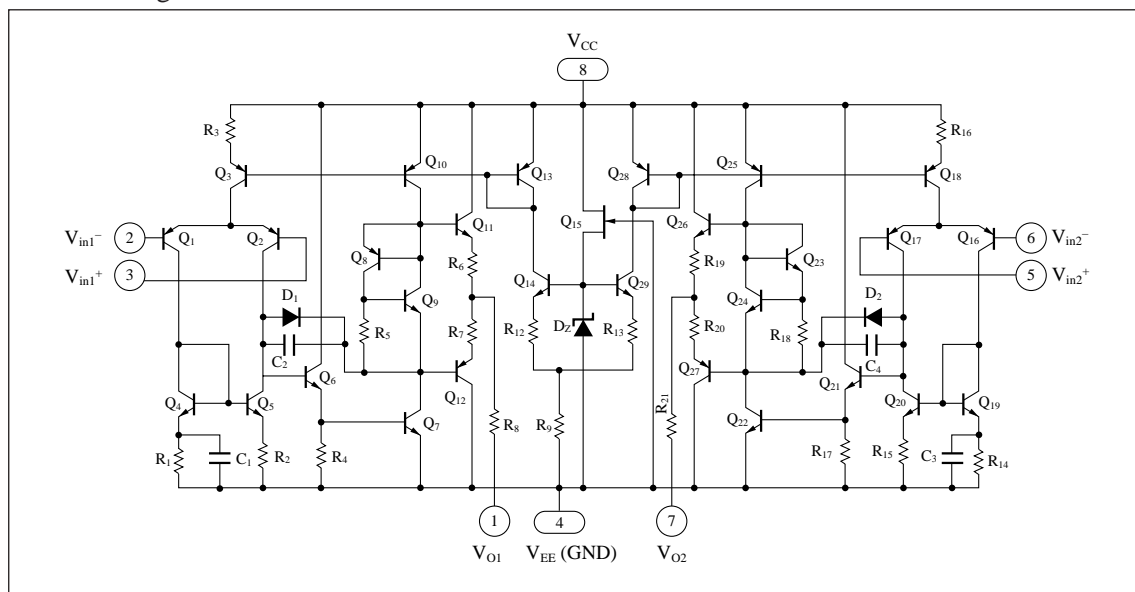

■ Absolute Maximum Ratings (Ta=25°C)

Parameter		Symbol	Rating	Unit
Voltage	Supply voltage	V_{CC}	± 18	V
	Differential input voltage	V_{ID}	± 30	V
	Common-mode input voltage	V_{ICM}	± 15	V
Power dissipation		P_D	500	mW
Temperature	Operating ambient temperature	T_{opr}	-20 to +75	°C
	Storage temperature	T_{stg}	-55 to +150	°C

■ Electrical Characteristics (V_{CC}=15V, V_{EE}=-15V, Ta=25°C)

Parameter	Symbol	Condition	min	typ	max	Unit
Input offset voltage	$V_{I(offset)}$	$R_S \leq 10k\Omega$	—	0.5	6	mV
Input offset current	I_{IO}		—	5	200	nA
Input bias current	I_{Bias}		—	—	500	nA
Voltage gain	G_V	$R_L \geq 2k\Omega, V_O = \pm 10V$	86	100	—	dB
Maximum output voltage	$V_{O(max)}$	$R_L \geq 10k\Omega$	± 12	± 14	—	V
		$R_L \geq 2k\Omega$	± 10	± 13	—	V
Common-mode input voltage width	V_{CM}		± 12	± 14	—	V
Common-mode rejection ratio	CMR		70	90	—	dB
Supply voltage rejection ratio	SVR		—	30	150	$\mu V/V$
Power consumption	P_C	$R_L = \infty$	—	90	170	mW
Slew rate	SR	$R_L \geq 2k\Omega$	—	2.0	—	V/ μs
Equivalent input noise voltage	V_{ni}	$R_S = 1k\Omega, B = 10Hz \text{ to } 30kHz$	—	2.5	—	μV_{rms}

■ Block Diagram

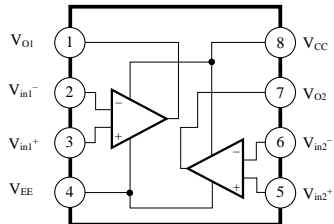

■ Pin Descriptions

Pin No.	Pin name
1	Ch.1 output
2	Ch.1 inverting input
3	Ch.1 non inverting input
4	V _{EE}
5	Ch.2 non inverting input
6	Ch.2 inverting input
7	Ch.2 output
8	V _{CC}

■ Characteristics Curve

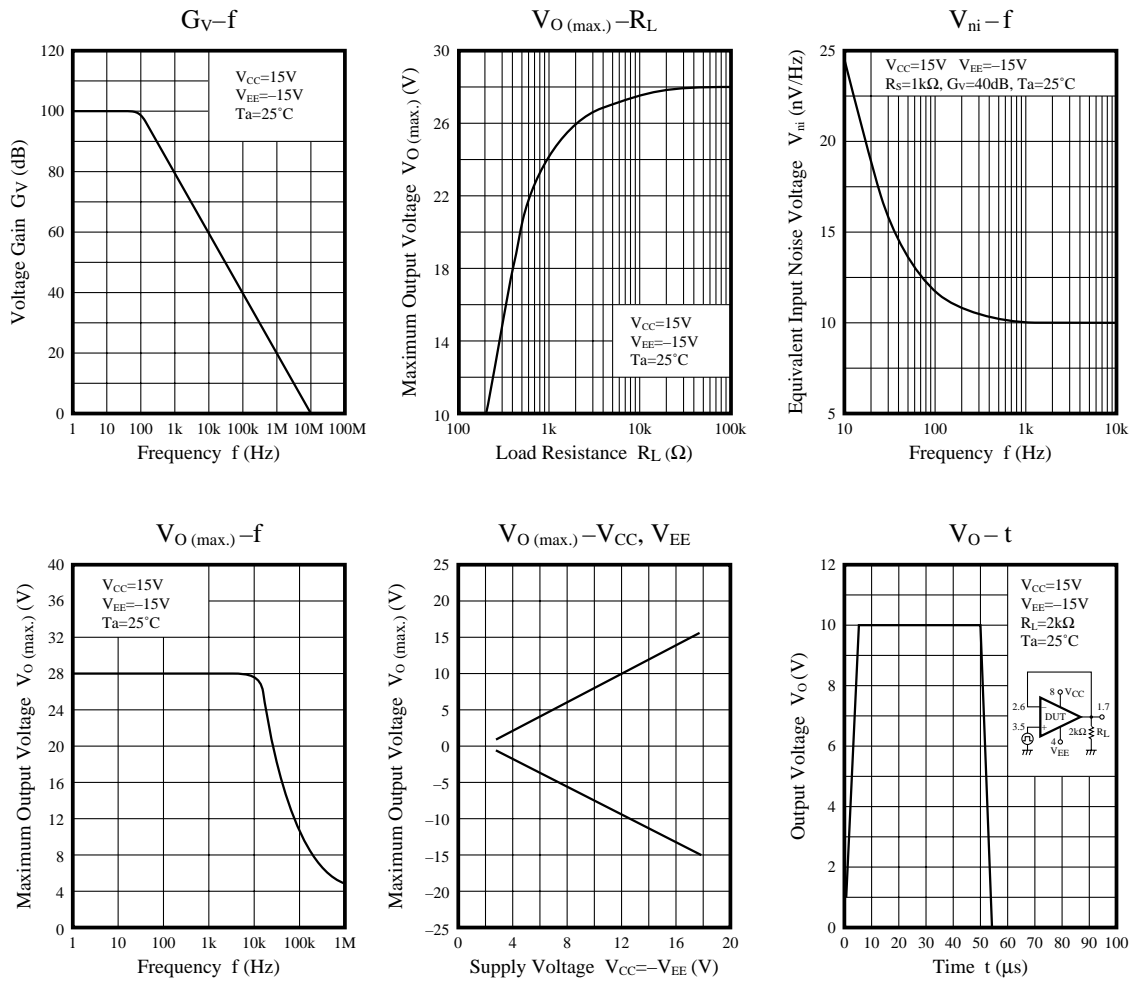

■ Application Circuit

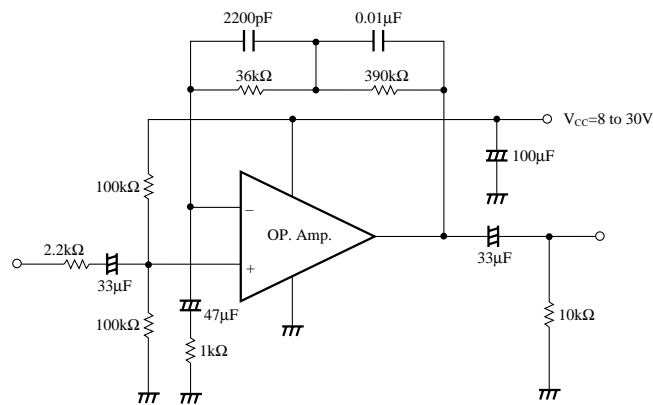

RIAA Pre-amp. (Single voltage operation)



LittleDiode supplies new, hard to find or obsolete electronic components and semiconductors all over the world.

With over two million different components listed you are sure to find the part you need.

Feel free to visit us today at our online store:

LittleDiode.com

Looking forward to providing you with the best possible service.