

AN6454SH

Pager Direct Conversion FSK Demodulator Mixer IC

■ Overview

The AN6454SH supports direct conversion FSK demodulation for pagers, and incorporates two mixers.

■ Features

- Low current consumption : 1mA
- Incorporates two mixers. 450MHz input frequency.
- Small surface-mount package with 0.5mm pitch.

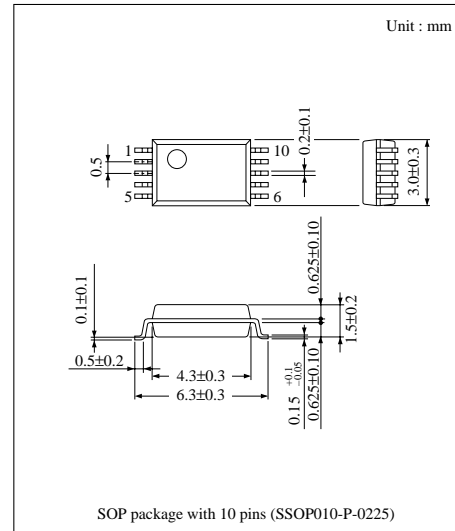

■ Pin Descriptions

Pin No.	Description	Pin No.	Description
1	MIX bias	6	MIX (2) output
2	L-OSC input (1)	7	MIX (1) output
3	L-OSC input (2)	8	GND
4	MIX current control	9	RF bias
5	V _{CC}	10	RF input

■ Functional Block Diagram

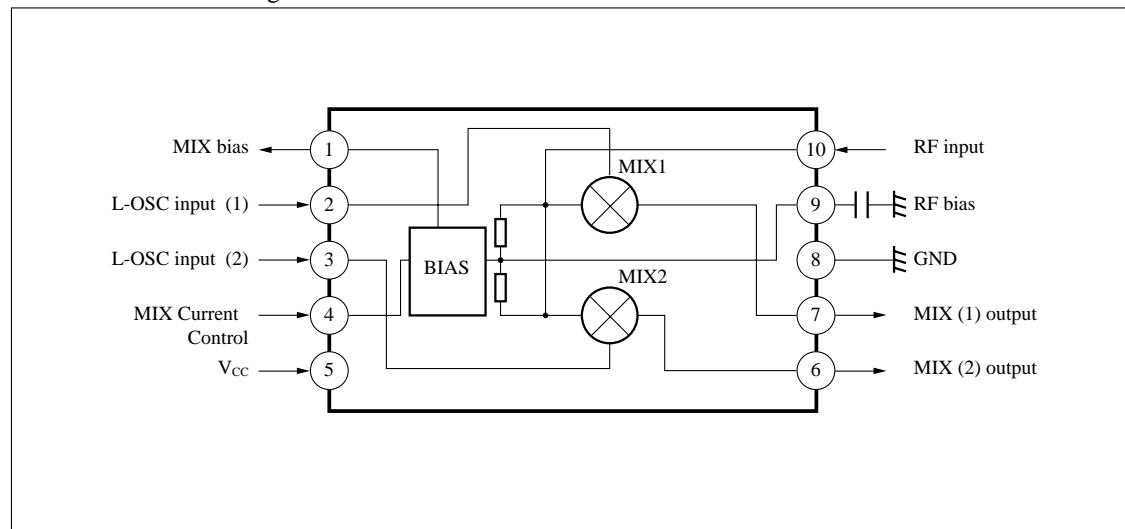

■ Absolute Maximum Ratings (Ta=25°C)

Parameter	Symbol	Rating	Unit
Supply voltage	V _{CC}	4	V
Supply current	I _{CC}	20	mA
Power dissipation	P _D	143.5 (Ta=75°C)	mW
Operating ambient temperature	T _{opr}	-20 to +70	°C
Storage temperature	T _{stg}	-55 to +125	°C

Note) Protect pins 3, 9, and 10 from electrostatic discharge.

■ Recommended Operating Range

Parameter	Symbol	Range
Operating supply voltage range	V _{CC}	1.8 to 3V

■ Electrical Characteristics (V_{CC}=2.0V, Ta=25±2°C)

Parameter	Symbol	Condition	min	typ	max	Unit
Current consumption	I _{tot}		0.6	1.0	1.4	mA
MIX output level (1)	VMIX1	Input Level -54dBm, f=450.0045MHz	-38	-34	-30	dBs
MIX output level (2)	VMIX1	Input Level -54dBm, f=450.0045MHz	-38	-34	-30	dBs

■ Electrical Characteristics (Design Values for Reference) (V_{CC}=2.0V, Ta=25±2°C)

The following are design values for reference only (not guaranteed)

Parameter	Symbol	Condition	min	typ	max	Unit
RF bias voltage	V _{RF}		—	0.745	—	V
MIX bias current	VMIX		—	1.3	—	V
MIX output level difference	DV _{mix}	DV _{mix} =V _{mix1} -V _{mix2}	-3.2	—	3.2	dB
Output noise level	V _{n3}	$V_{n3} = \sqrt{\frac{(V_{n2})^2 + (V_{n1})^2}{2}}$	—	—	25	dBs

■ Pin Descriptions

Pin No.	Symbol	Description	Equivalent circuit
1	MIX bias	Local oscillator bias. Normally grounded though a capacitor.	
2	L-OSC input 1	Local oscillator inputs to Pin2 w and 3 are different in phase by $\pi/2$. These inputs are different in frequency by FM Dev from Pin 10 input.	
3	L-OSC input 2		
4	MIX-current control	Current input to this pin controls the IC's operation and total current. This pin may be connected to Pin 22 of AN6400.	
5	V _{CC}	This is the supply voltage pin.	
6	MIX2 output	Direct-conversion mixer outputs (FM Dev.). These outputs are different in phase by $\pi/2$ from each other. These pins may be to AN6400 or other direct conversion demodulator ICs for data retrieval.	
7	MIX1 output		

■ Pin Descriptions (Cont.)

Pin No.	Symbol	Description	Equivalent circuit
8	GND	This is the ground pin.	—————
9	RF bias	This is the bias pin for RF input to Pin 10. The bias is internally provided. This pin must be ground through a capacitor.	
10	RF input	FSK-modulated RF signals from an RF amplifier are input to this pin. RF signals with up to 450MHz are acceptable.	



LittleDiode supplies new, hard to find or obsolete electronic components and semiconductors all over the world.

With over two million different components listed you are sure to find the part you need.

Feel free to visit us today at our online store:

LittleDiode.com

Looking forward to providing you with the best possible service.