

MAINS RECTIFICATION FOR THE GS100T300-x

The GS100T300-x is a family of DC-DC converters with different output voltages (x), that can deliver an output power of 100 Watt when an unregulated DC voltage source of 300 V typical is available.

The key data for GS100T300-x are:

- P_o = Output power = 100 Watt
- V_o = Output voltage = from 3.3 to 48 V_{DC}
- η = Efficiency = 80 % min.
- V_{in} = Input voltage = 200 to 400 V_{DC}
- I_{inRMS} = Input RMS current = 0.88 A_{RMS}

The following note describes how to obtain an unregulated DC input voltage from the mains. Four examples are considered: the Europe and Usa mains, and, for each of them, with and without the hold-on characteristic.

The hold-on characteristic is the ability of the input voltage source to maintain a DC voltage higher than the minimum input voltage of the DC-DC converter, even in case of a mains interruption of 1 cycle.

1. European mains without the hold on characteristic.

The European mains characteristics are:

- $V_{inac} = 230 V_{RMS} \pm 15 \%$
- $240 V_{RMS} \pm 10 \%$
- $f = 50 \text{ Hz}$

The minimum AC voltage is, therefore, 195 V_{RMS} while the maximum AC voltage is 264 V_{RMS}. A bridge rectifier as shown in fig. 1 can be used to obtain the required unregulated DC voltage.

Figure 1: AC-DC converter for Europe Mains.

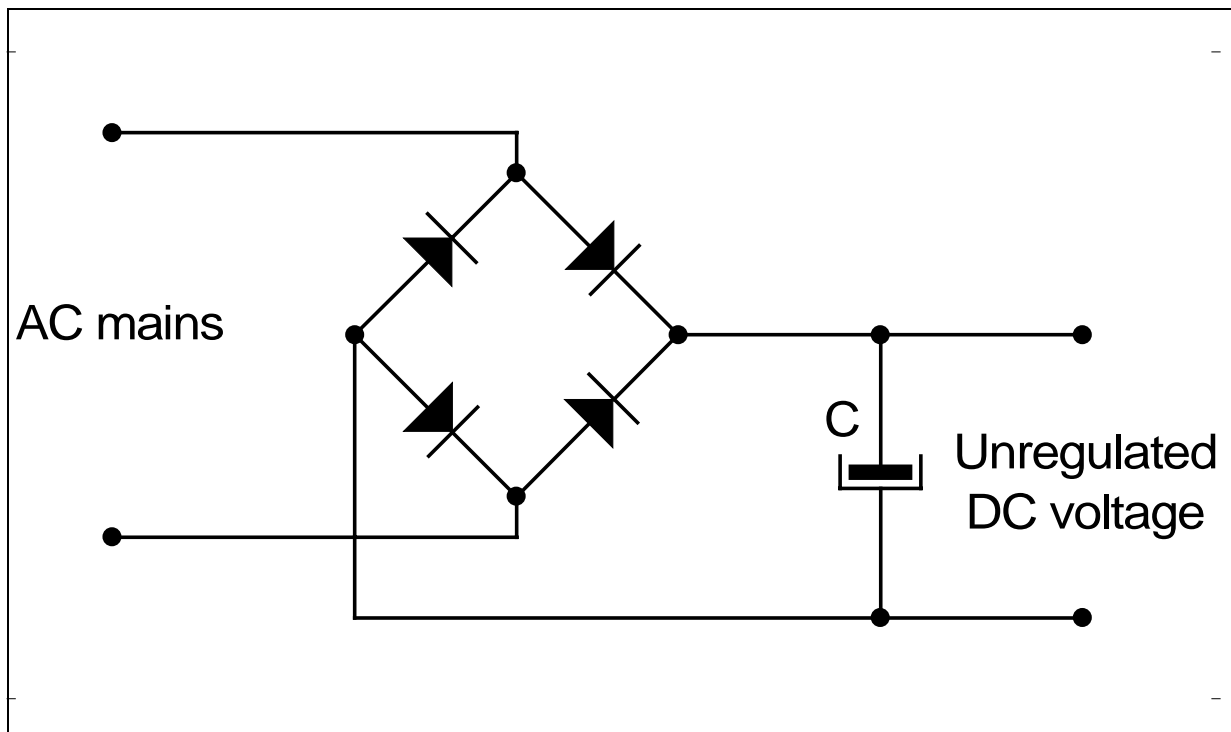

MAINS RECTIFICATION AND FILTERING

The typical waveform for this type of rectifier is shown in fig. 2 where:

- V_c = Voltage across capacitor C.
- V_{pk} = peak value of the input AC voltage.
- V_{min} = minimum voltage across capacitor C.
- t_{ch} = charging time of the capacitor C
- t_{dch} = discharging time of the capacitor C
- i_{ch} = peak charge current for the capacitor C
- I_{dc} = average input current
- T = total time for one complete cycle

The total energy W_{in} to be supplied by the capacitor C during one full cycle of the mains is:

$$W_{in} = \frac{P_{in}}{f} = \frac{P_o}{\eta \cdot f} \quad (1)$$

where P_{in} is the input power in Watt of the GS100T300-x and f is the mains frequency in Hz. In this case:

$$W_{in} = \frac{100}{0.8 \cdot 50} = 2.5 \text{ W} \cdot \text{s}$$

During each half cycle, the capacitor has to deliver $1/2 W_{in}$ and its voltage will drop from V_{pk} to V_{min} . The following equation applies:

$$\frac{1}{2} W_{in} = \frac{1}{2} C (V_{PK}^2 - V_{min}^2) \quad (2)$$

therefore

$$C = \frac{W_{in}}{V_{pk}^2 - V_{min}^2} \quad (3)$$

In this case:

$$V_{pk} = \sqrt{2} \cdot V_{inRMSmin} - 4 = 1.41 \cdot 195 - 4 = 271 \text{ V}$$

Where 4 V is a good assumption for the voltage drop across the rectifying diodes and the input filter. According to the GS100T300-x data, $V_{min}=200 \text{ V}$. Therefore, from equation (3):

$$C = \frac{2.5}{271^2 - 200^2} = 75 \mu\text{F}$$

Figure 2. Typical waveform for the circuit of fig. 1

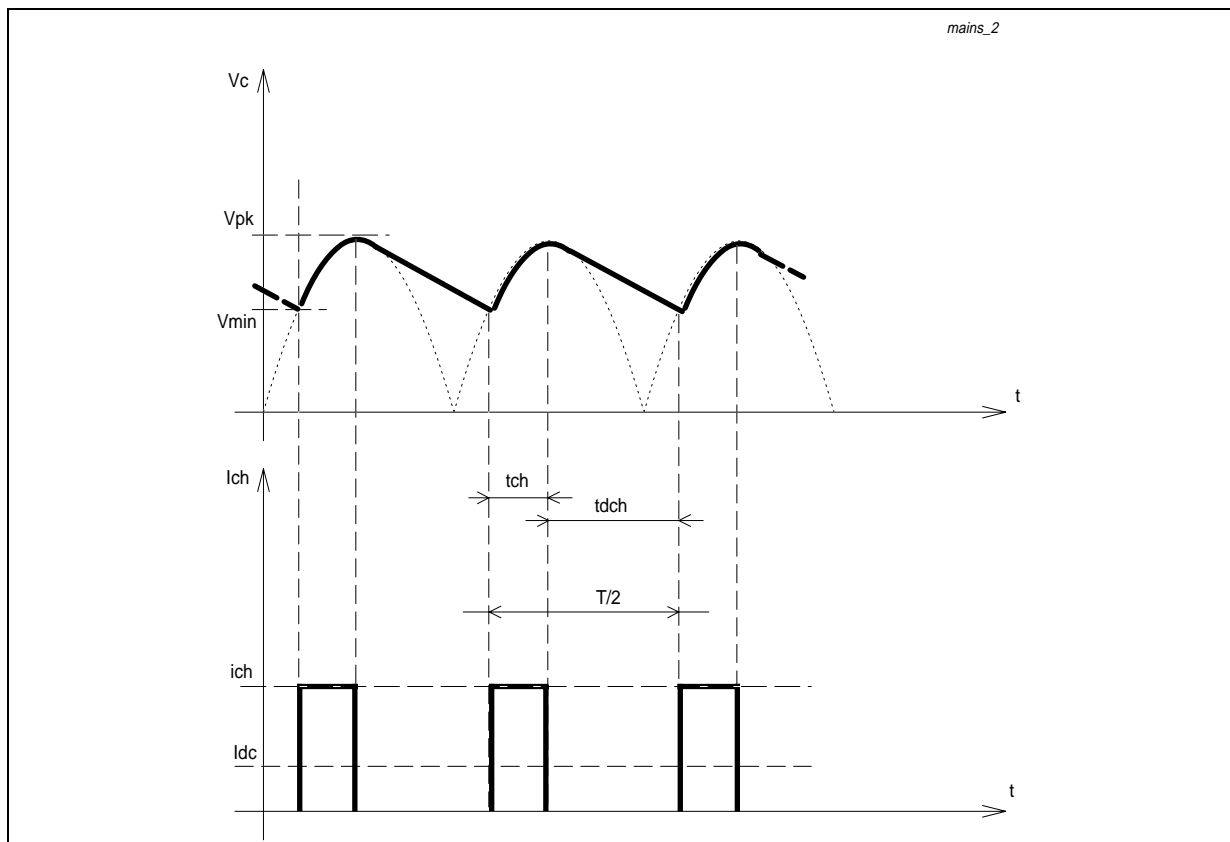

The nearest available value is 82μF. By using this value, the new V_{min} is given by:

$$V_{\min} = \sqrt{V_{\text{pk}}^2 - \frac{W_{\text{in}}}{C}} \quad (4)$$

and so:

$$V_{\min} = \sqrt{271^2 - \frac{2.5}{82 \cdot 10^{-6}}} = 207 \text{ V}$$

The ripple voltage across the capacitor is:

$$V_{\text{ripple}} = V_{\text{pk}} - V_{\min} \quad (5)$$

$$V_{\text{ripple}} = 271 - 207 = 64 \text{ V}_{\text{p-p}}$$

The maximum voltage across C is obtained when the AC input voltage is at its maximum and the DC-DC converter does not deliver power. In this case the voltage drop across the diodes and the filter is about 2 V so that the maximum voltage is:

$$\begin{aligned} V_{\text{PKmax}} &= \sqrt{2} \cdot V_{\text{inRMSmax}} - 2 = \\ &= 1.41 \cdot 264 - 2 = 370 \text{ V} \end{aligned}$$

From fig. 2, it may be assumed that the charging current is flowing during the time t_{ch} and with a rectangular shape with a peak value of i_{ch}. The charging time is given by:

$$t_{\text{ch}} = \frac{T}{2\pi} \cos^{-1} \frac{V_{\min}}{V_{\text{pk}}} \quad (6)$$

$$t_{\text{ch}} = \frac{20 \cdot 10^{-3}}{2\pi} \cos^{-1} \frac{207}{271} = 2.23 \text{ ms}$$

The charging peak current is given by:

$$i_{\text{ch}} = C \frac{V_{\text{pk}} - V_{\min}}{t_{\text{ch}}} \quad (7)$$

therefore:

$$i_{\text{ch}} = 82 \cdot 10^{-6} \frac{271 - 207}{2.23 \cdot 10^{-3}} = 2.35 \text{ A}_\text{p}$$

The RMS value of the input current is given by:

$$I_{\text{in(RMS)}} = i_{\text{ch}} \sqrt{\delta} \quad (8)$$

where δ is the duty cycle i.e. the diodes conduction time (t_{ch}) divided by T/2:

$$\delta = \frac{2 t_{\text{ch}}}{T} \quad (9)$$

The average value of the input current is given by:

$$I_{\text{in(AVG)}} = i_{\text{ch}} \cdot \delta \quad (10)$$

From equations (8), (9) and (10):

$$\delta = \frac{2 \cdot 2.23 \cdot 10^{-3}}{20 \cdot 10^{-3}} = 0.223$$

$$I_{\text{in(RMS)}} = 2.35 \sqrt{0.223} = 1.11 \text{ A}_{\text{RMS}}$$

$$I_{\text{in(AVG)}} = 2.35 \cdot 0.223 = 0.524 \text{ A}_{\text{DC}}$$

The RMS current across the capacitor is the difference between the input RMS current and the input average current that is not flowing through the capacitor:

$$I_{\text{cap(RMS)}} = \sqrt{I_{\text{in(RMS)}}^2 - I_{\text{in(AVG)}}^2} \quad (11)$$

$$I_{\text{cap(RMS)}} = \sqrt{1.11^2 - 0.524^2} = 0.978 \text{ A}_{\text{RMS}}$$

The equation (11) is valid if the circuit of fig. 1 is connected to a DC load. The GS100T300-x is a switch mode DC-DC converter so that also the input RMS current of the converter (0,88 A_{RMS}) is flowing through the capacitor.

Therefore

$$I_{\text{capTOT(RMS)}} = \sqrt{I_{\text{cap(RMS)}}^2 + I_{\text{DC-DC(RMS)}}^2} \quad (12)$$

$$I_{\text{capTOT(RMS)}} = \sqrt{0.978^2 + 0.88^2} = 1.31 \text{ A}_{\text{RMS}}$$

2. European mains with hold-on characteristics

In this case the capacitor C must be able to deliver the whole energy during one complete mains cycle-failure.

The input waveform is shown in fig. 3, where:

V_{pf} = Voltage across the capacitor after one cycle of power fail.

The worst case is when the mains interruption happens when the capacitor voltage is already at V_{min}; the following equation applies:

$$W_{\text{in}} = \frac{1}{2} C (V_{\text{min}}^2 - V_{\text{pf}}^2) \quad (13)$$

Equation (2) is still valid. By combining equation (2) and (13)

$$V_{\text{PK}}^2 - V_{\text{min}}^2 = \frac{1}{2} (V_{\text{min}}^2 - V_{\text{pf}}^2)$$

MAINS RECTIFICATION AND FILTERING

therefore

$$V_{\min} = \sqrt{\frac{1}{3} (2 \cdot V_{\text{pk}}^2 + V_{\text{pf}}^2)} \quad (14)$$

from equation (13)

$$C = \frac{2W_{\text{in}}}{V_{\min}^2 - V_{\text{pf}}^2} \quad (15)$$

By combining eq. (14) and eq. (15)

$$C = \frac{3W_{\text{in}}}{V_{\text{pk}}^2 - V_{\text{pf}}^2} \quad (16)$$

By assuming $V_{\text{pk}} = 271 \text{ V}$ and $V_{\text{pf}} = 200 \text{ V}$

$$C = \frac{3 \cdot 2.5}{271^2 - 200^2} = 224 \mu\text{F}$$

The nearest higher value is $270 \mu\text{F}$. By adopting this value

$$V_{\text{pf}} = \sqrt{V_{\text{pk}}^2 - \frac{3W_{\text{in}}}{C}} \quad (17)$$

$$V_{\text{pf}} = \sqrt{271^2 - \frac{3 \cdot 2.5}{270 \cdot 10^{-6}}} = 214 \text{ V}$$

$$V_{\min} = \sqrt{\frac{1}{3} (2 \cdot 271^2 + 214^2)} = 254 \text{ V}$$

$$V_{\text{Ripple}} = V_{\text{pk}} - V_{\min} = 271 - 254 = 17 \text{ V}_{\text{p-p}}$$

$$t_{\text{ch}} = \frac{20 \cdot 10^{-3}}{2\pi} \cos^{-1} \frac{254}{271} = 1.14 \text{ ms}$$

$$i_{\text{ch}} = 270 \cdot 10^{-6} \cdot \frac{271 - 254}{1.14 \cdot 10^{-3}} = 4.03 \text{ A}_{\text{p}}$$

$$I_{\text{in(RMS)}} = 4.03 \sqrt{\frac{1.14}{10}} = 1.36 \text{ A}_{\text{RMS}}$$

$$I_{\text{in(AVG)}} = 4.03 \cdot \frac{1.14}{10} = 0.46 \text{ A}_{\text{DC}}$$

$$I_{\text{cap(RMS)}} = \sqrt{1.36^2 - 0.46^2} = 1.28 \text{ A}_{\text{RMS}}$$

$$I_{\text{capTOT(RMS)}} = \sqrt{1.28^2 + 0.88^2} = 1.55 \text{ A}_{\text{RMS}}$$

Figure 3. Typical waveform with one cycle of power failure

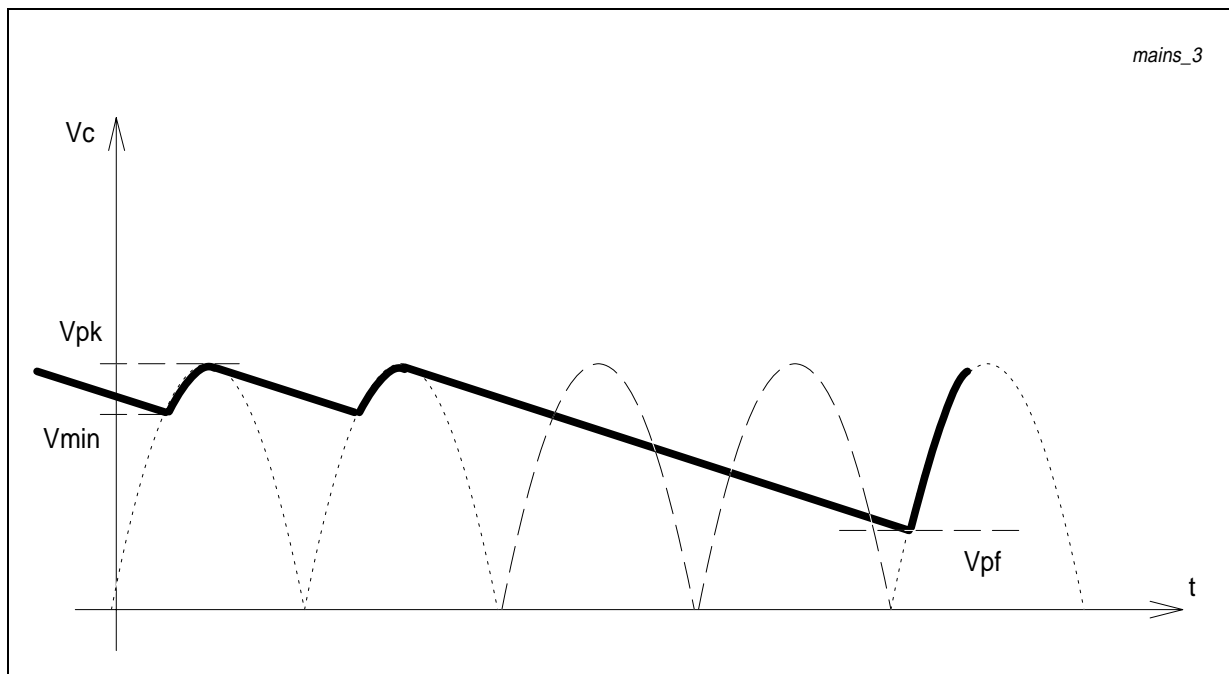

MAINS RECTIFICATION AND FILTERING

The key results are summarized in the following table:

European mains: $V_{inac}=195V_{RMS}$ min; $230 V_{RMS}$ typ; $264 V_{RMS}$ max
 $f=50Hz$ $W_{in} = 2.5 W \times Sec.$

Parameter	Without hold-on	With hold-on	Unit
C	82	270	μF
Vmin	207	254	V
Vpf	-	214	V
VRipple	64	17	Vp-p
Vmax	370	370	V
ich	2,35	4,03	Ap
tch	2,23	1,14	ms
Iin(RMS)	1,11	1,36	ARMS
Iin(AVG)	0,524	0,46	ADC
IcapTOT(RMS)	1,32	1,55	ARMS

3. Usa mains without the hold-on characteristics

The USA mains characteristics are:

$$V_{INAC} = 117 V_{RMS} \pm 15 \% \quad 60 \text{ Hz}$$

To reach the minimum input voltage required by the GS100T300-x, a voltage doubler configuration is required as shown in fig. 4.

C1 and C2 are alternatively charged to peak line voltage minus the voltage drop across the input filter and one diode of the rectifying bridge so that a voltage drop of 2V may be assumed. The waveforms are shown on fig. 5.

By assuming a linear discharge of the capacitors, when the capacitor C1 reaches its minimum (V_{c1min}), the voltage of the capacitor C2 is half way between V_{pk} and V_{c2min} .

Figure 4. AC-DC converter for USA mains.

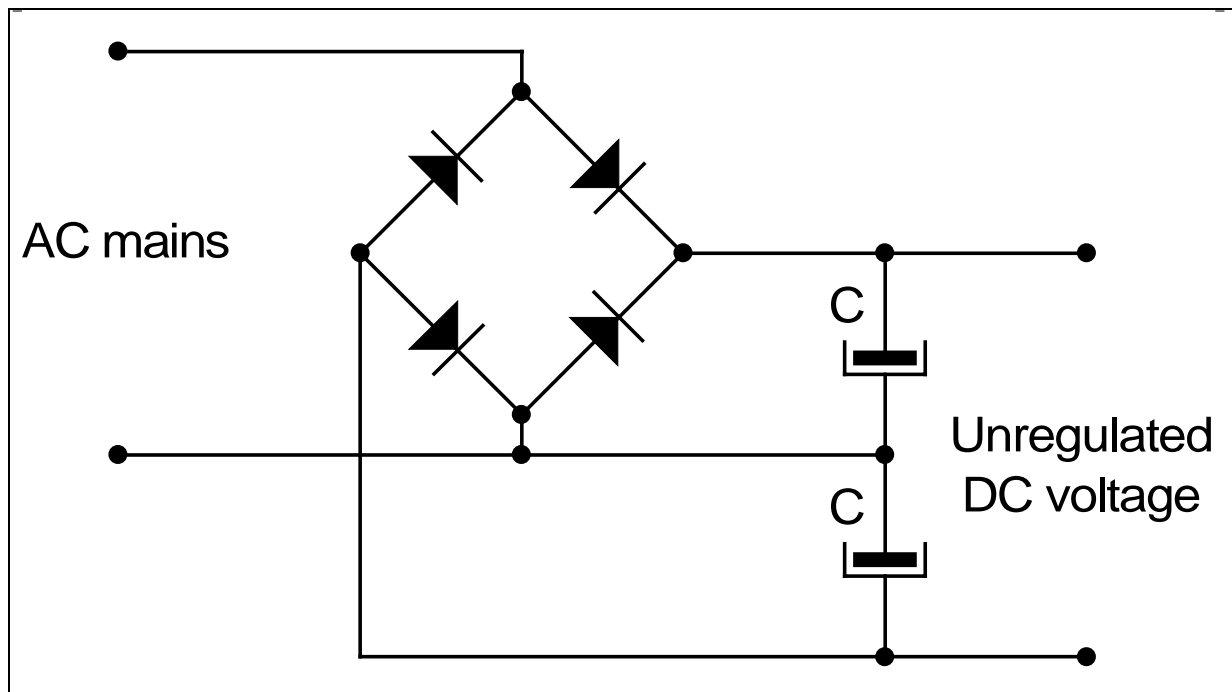

MAINS RECTIFICATION AND FILTERING

Therefore:

$$V_{\min} = V_{C1\min} + \frac{V_{PK} + V_{C2\min}}{2}$$

If $C1=C2=C$

$$V_{\min} = \frac{3 V_{C\min} + V_{PK}}{2} \quad (18)$$

Each capacitor has to supply one half of the energy required by the GS100T300-x for an entire line cycle.

Therefore:

$$\frac{1}{2} W_{in} = \frac{1}{2} C (V_{PK}^2 - V_{C\min}^2)$$

$$C = \frac{W_{in}}{V_{PK}^2 - V_{C\min}^2} \quad (19)$$

From equation (18)

$$V_{C\min} = \frac{2 V_{\min} - V_{PK}}{3} \quad (20)$$

In the case of the USA mains:

$$V_{PK} = \sqrt{2} \cdot 117 \cdot 0.85 - 2 = 138 \text{ V}_p$$

$$W_{in} = \frac{P_{in}}{f} = \frac{P_0}{\eta \cdot f} = \frac{100}{0.8 \cdot 60} = 2.08 \text{ W} \cdot \text{s}$$

By imposing $V_{\min} = 200\text{V}$, from equation (20)

$$V_{C\min} = \frac{2 \cdot 200 - 138}{3} = 87 \text{ V}$$

and from equation (19)

$$C = \frac{2.08}{138^2 - 87^2} = 181 \mu\text{F}$$

The nearest higher value is $C=220\mu\text{F}$. By adopting this value, from equation (19)

$$V_{C\min} = \sqrt{V_{pk}^2 - \frac{W_{in}}{C}} \quad (21)$$

$$V_{C\min} = \sqrt{138^2 - \frac{2.08}{220 \cdot 10^{-6}}} = 98 \text{ V}$$

Figure 5. Waveform for the voltage doubler configuration

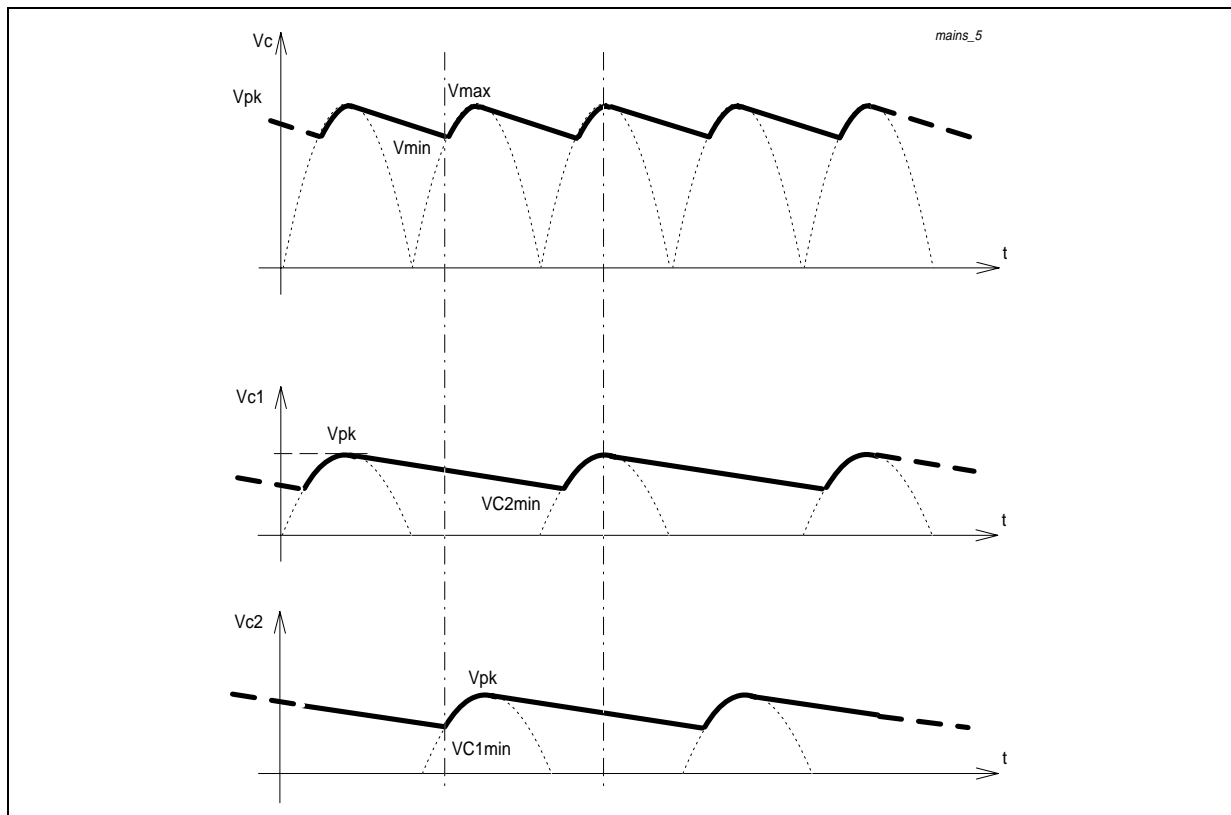

and from equation (18)

$$V_{\min} = \frac{3 \cdot 98 + 138}{2} = 216 \text{ V}$$

From fig. 5

$$V_{\max} = V_{PK} + \frac{V_{PK} + V_{C\min}}{2} = 138 + \frac{138 + 98}{2} = 256 \text{ V}$$

$$V_{\text{Ripple}} = V_{\max} - V_{\min} = 256 - 216 = 40 \text{ V}_{p-p}$$

Equations (6),(7),(8),(9),(10),(11),(12) are still valid. However, since the capacitors are charged every other half cycle, the duty cycle is given by:

$$\delta = \frac{t_{ch}}{T}$$

$$t_{ch} = \frac{1}{2 \cdot \pi \cdot 60} \cos^{-1} \frac{98}{138} = 2.07 \text{ ms}$$

$$i_{ch} = 220 \cdot 10^{-6} \cdot \frac{138 - 98}{2.07 \cdot 10^{-3}} = 4.25 \text{ A}_p$$

$$\delta = 2.07 \cdot 10^{-3} \cdot 60 = 0.124$$

$$I_{inRMS} = 4.25 \sqrt{0.124} = 1.49 \text{ A}_{RMS}$$

$$I_{inAVG} = 4.25 \cdot 0.124 = 0.53 \text{ A}_{DC}$$

$$I_{capRMS} = \sqrt{1.49^2 - 0.53^2} = 1.39 \text{ A}_{RMS}$$

$$I_{cap\ totRMS} = \sqrt{1.39^2 + 0.88^2} = 1.64 \text{ A}_{RMS}$$

When the AC mains is at its maximum (134 V_{RMS})

$$V_{pk} = \sqrt{2} \cdot 134 - 2 = 187 \text{ V}$$

$$V_{C\min} = \sqrt{187^2 - \frac{2.08}{220 \cdot 10^{-6}}} = 160 \text{ V}$$

$$V_{\min} = \frac{3 \cdot 160 + 187}{2} = 333 \text{ V}$$

$$V_{\max} = 187 + \frac{187 + 160}{2} = 360.5 \text{ V}$$

$$V_{\text{Ripple}} = 360.5 - 333 = 27.5 \text{ V}_{p-p}$$

4. USA mains with hold-on characteristics

From fig. 5, during a mains failure of one cycle, the two capacitors in series must provide all the energy required by the GS100T300-x for the same period.

By supposing that the power fail occurs when the total voltage is V_{MIN}, the voltage at the end of 1 cycle failure (V_{pf}) is obtained by

$$W_{in} = \frac{1}{2} C_{eq} \cdot (V_{\min}^2 - V_{pf}^2) \quad (22)$$

$$\text{where: } C_{eq} = \frac{1}{2} C$$

$$C = \frac{4 W_{in}}{V_{\min}^2 - V_{pf}^2}$$

Equation (18), (21) and (23) must be valid at the same time. After some straightforward calculations the value of C is 406 μF. The nearest higher value is 470 μF. From equation (21)

$$V_{C\min} = \sqrt{138^2 - \frac{2.08}{470 \cdot 10^{-6}}} = 120.9 \text{ V}$$

From equation (18)

$$V_{\min} = \frac{3 \cdot 120.9 + 138}{2} = 250.36 \text{ V}$$

The voltage after 1 cycle of power fail is given by

$$V_{pf} = \sqrt{V_{\min}^2 - \frac{4 W_{in}}{C}} \quad (24)$$

$$V_{pf} = \sqrt{250.36^2 - \frac{4 \cdot 2.08}{470 \cdot 10^{-6}}} = 212 \text{ V}$$

By applying equations (6), (7), (8), (9), (10), (11) and (12) the following values are obtained:

$$t_{ch} = \frac{1}{2 \cdot \pi \cdot 60} \cos^{-1} \frac{120.9}{138} = 1.33 \text{ ms}$$

$$i_{ch} = 470 \cdot 10^{-6} \cdot \frac{138 - 120.9}{1.33 \cdot 10^{-3}} = 6.02 \text{ A}_p$$

$$\delta = 1.33 \cdot 10^{-3} \cdot 60 = 0.08$$

$$I_{inRMS} = 6.02 \cdot \sqrt{0.08} = 1.7 \text{ A}_{RMS}$$

$$I_{inAVG} = 6.02 \cdot 0.08 = 0.48 \text{ A}_{DC}$$

$$I_{capRMS} = \sqrt{1.7^2 - 0.48^2} = 1.63 \text{ A}_{RMS}$$

$$I_{capTOT} (RMS) = \sqrt{1.63^2 + 0.88^2} = 1.85 \text{ A}_{RMS}$$

Figure 6b. Different AC-DC converter configurations (USA versions)

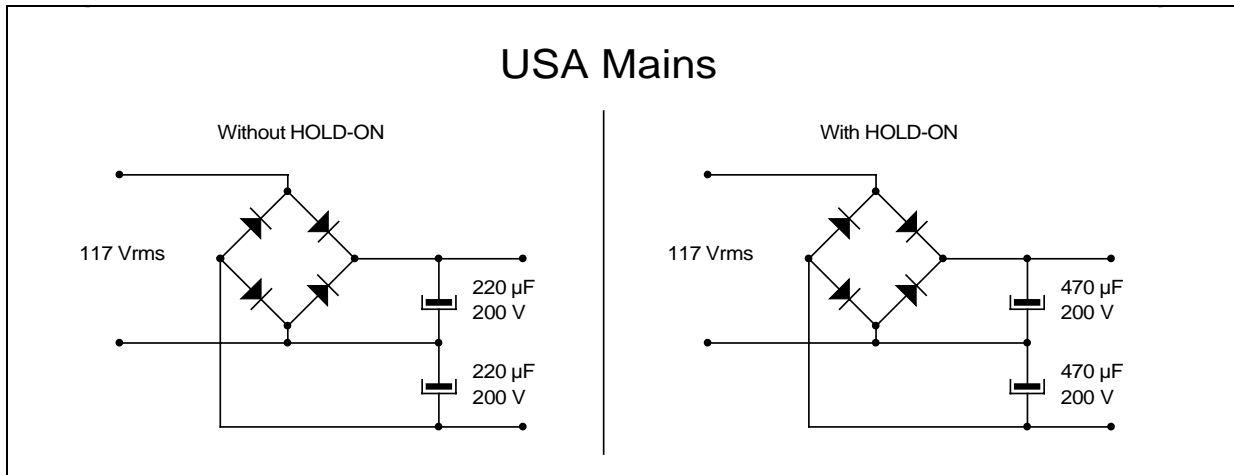

5. Ripple current of the filtering capacitor

The previous calculations don't take into account that the capacitance value and the maximum ripple current are not independent. In other words available capacitors of a given capacitance may not meet the requirements for ripple current.

For example, in the case of the European Mains without hold-on, the minimum required capacitance is 82 µF and the maximum ripple current is 1.32 A_{RMS}. While the calculation is correct, such a capacitor doesn't exist: available capacitors of 82 µF / 400 V have a ripple current capability that is 1/3 of the required value at the best.

The designer has to repeat the calculation according to the available capacitors that meet the ripple current requirement, the allowed value for a given application, the cost, etc.

An example is reported in the following. An available series of capacitors has the following data:

C (µF)	Ripple Current - A _{RMS} @ 85 °C
47	0.71
68	0.84
100	1.04
150	1.23
220	1.50
330	1.80

From the table, the increase in ripple current capability is not proportional to the increase of capacitance. For the two extreme values, the increase of capacitance is 330 / 47 = 7.02 while the increase in ripple current capability is 180 / 0.71 = 2.53.

Therefore it is more convenient to use smaller capacitors in parallel rather than one single capacitor at high value of capacitance.

For this example, 2 capacitors of 68 µF are used in parallel, therefore C = 2 x 68 µF = 136 µF. The

calculated values are modified as follows.

$$V_{min} = \sqrt{V_{PK}^2 - \frac{W_{in}}{C}} = \sqrt{271^2 - \frac{2.5}{136 \cdot 10^{-6}}} = 235 \text{ V}$$

$$V_{Ripple} = V_{PK} - V_{min} = 271 - 235 = 36 \text{ V}_{p-p}$$

$$t_{ch} = \frac{1}{2 \pi f} \cos^{-1} \frac{V_{min}}{V_{PK}} = \frac{1}{2 \pi \cdot 50} \cos^{-1} \frac{235}{271} = 1.66 \text{ ms}$$

$$i_{ch} = C \frac{V_{PK} - V_{min}}{t_{ch}} = 136 \cdot 10^{-6} \cdot \frac{271 - 235}{1.66 \cdot 10^{-3}} = 2.94 \text{ A}_p$$

$$\delta = \frac{2 t_{ch}}{T} = \frac{2 \cdot 1.66}{20} = 0.166$$

$$I_{inRMS} = i_{ch} \cdot \sqrt{\delta} = 2.95 \cdot \sqrt{0.166} = 1.20 \text{ A}_{RMS}$$

$$I_{inAVG} = i_{ch} \cdot \delta = 2.95 \cdot 0.166 = 0.490 \text{ A}_{DC}$$

$$I_{cap \text{ tot}RMS} = \sqrt{I_{inRMS}^2 - I_{inAVG}^2 + I_{inDC-DCRMS}^2} = \sqrt{1.20^2 - 0.49^2 + 0.88^2} = 1.40 \text{ A}_{RMS}$$

The parallel of 2 capacitors has a current capability of 2 x 0.84 = 1.68 A_{RMS} so that the capacitors are not overstressed. The impedance of the two capacitors in parallel is about 0.1 Ohms at f = 100 kHz. The designer can repeat the calculations according to the application (European/USA mains, with or without hold-on) to different size and cost targets, etc.

MAINS RECTIFICATION AND FILTERING

Information furnished is believed to be accurate and reliable. However, SGS-THOMSON Microelectronics assumes no responsibility for the consequences of use of such information nor for any infringement of patents or other rights of third parties which may result from its use. No license is granted by implication or otherwise under any patent or patent rights of SGS-THOMSON Microelectronics. Specification mentioned in this publication are subject to change without notice. This publication supersedes and replaces all information previously supplied. SGS-THOMSON Microelectronics products are not authorized for use as critical components in life support devices or systems without express written approval of SGS-THOMSON Microelectronics.

© 1994 SGS-THOMSON Microelectronics – All Rights Reserved

SGS-THOMSON Microelectronics GROUP OF COMPANIES
Australia - Brazil - China - France - Germany - Hong Kong - Italy - Japan - Korea - Malaysia - Malta - Morocco - The Netherlands -
Singapore - Spain - Sweden - Switzerland - Taiwan - Thailand - United Kingdom - U.S.A.



LittleDiode supplies new, hard to find or obsolete electronic components and semiconductors all over the world.

With over two million different components listed you are sure to find the part you need.

Feel free to visit us today at our online store:

LittleDiode.com

Looking forward to providing you with the best possible service.