

SGS-THOMSON AND POWER SUPPLY SYSTEMS

Every electronic system must be supplied by electrical power to operate and the source of this electrical power may be of different kinds, some of which are shown generically in fig. 1

The Subsystems, Engineering and Back-End Division of SGS-THOMSON is very active in the domain of power supplies and the various product families have been designed by keeping in mind the general approach outlined in the conceptual block diagram shown in fig. 1.

One section of this data book is dedicated to block 1 - Battery chargers. In this field SGS-THOMSON can supply state-of-the-art products thanks to a deep know-how on the batteries behavior during charge, availability of excellent semiconductor components and mechanical design ability. Block 2 covers the field of OFF LINE power supplies.

SGS-THOMSON manufacture customized products only for this type of application i.e. products designed according to a customer specification. Therefore these products are not included into this data book. The variety of OFF LINE power supplies is so large that no standardization is possible and customers that buy off-the-shelf products have, necessarily, to accept compromises in terms of electrical performance, size and price.

SGS-THOMSON policy of "customized products only" allows the better performance and optimization from these points of view.

The problem of lack of standardization is partially compensated by a family of high voltage DC-DC converters, the GS100T300-xx covered in this book. These converters have a high and wide input voltage range (from 200 V_{DC} to 400 V_{DC}) so that a complete off line power supply can be easily build by the adoption of these converters complemented by the mains rectifier and filter.

Figure 1.

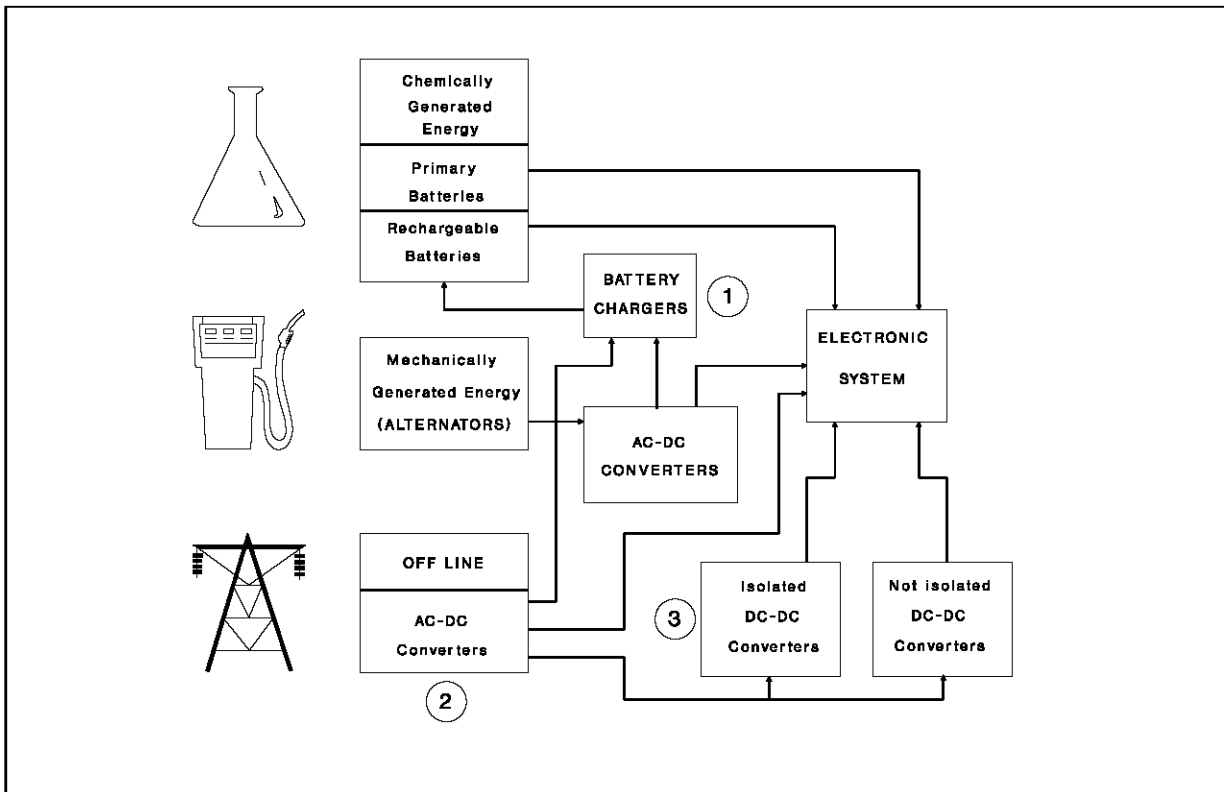

APPLICATION NOTES

Block 3 Isolated DC-DC converters and block 4 Non Isolated DC-DC Converters have been designed according to a strategy of distributed power architecture as shown in fig. 2

When an electronic equipment requires many different supply voltages, a central power supply system is not the best approach because of poor load regulation (long connecting cables will show significant voltage drops at high current), and because in a multiple outputs power supply just one output voltage is well controlled against line and load variations.

In this case it is preferable to generate the required DC voltage just at the point of its utilization by local regulation (on card or bus regulation).

This concept is shown in fig. 2 and a variety of families (GS-T families for isolated DC-DC converters and GS-R families of non isolated DC-DC regulators) are described in this data book.

The range of output power of these modules is quite large (from 0,1 W to 300 W) and many different output voltages are available.

The architecture of fig. 2 allows also the implementation of an easy back-up solution by connecting the 48 V bus to an adequate battery.

Figure 2.

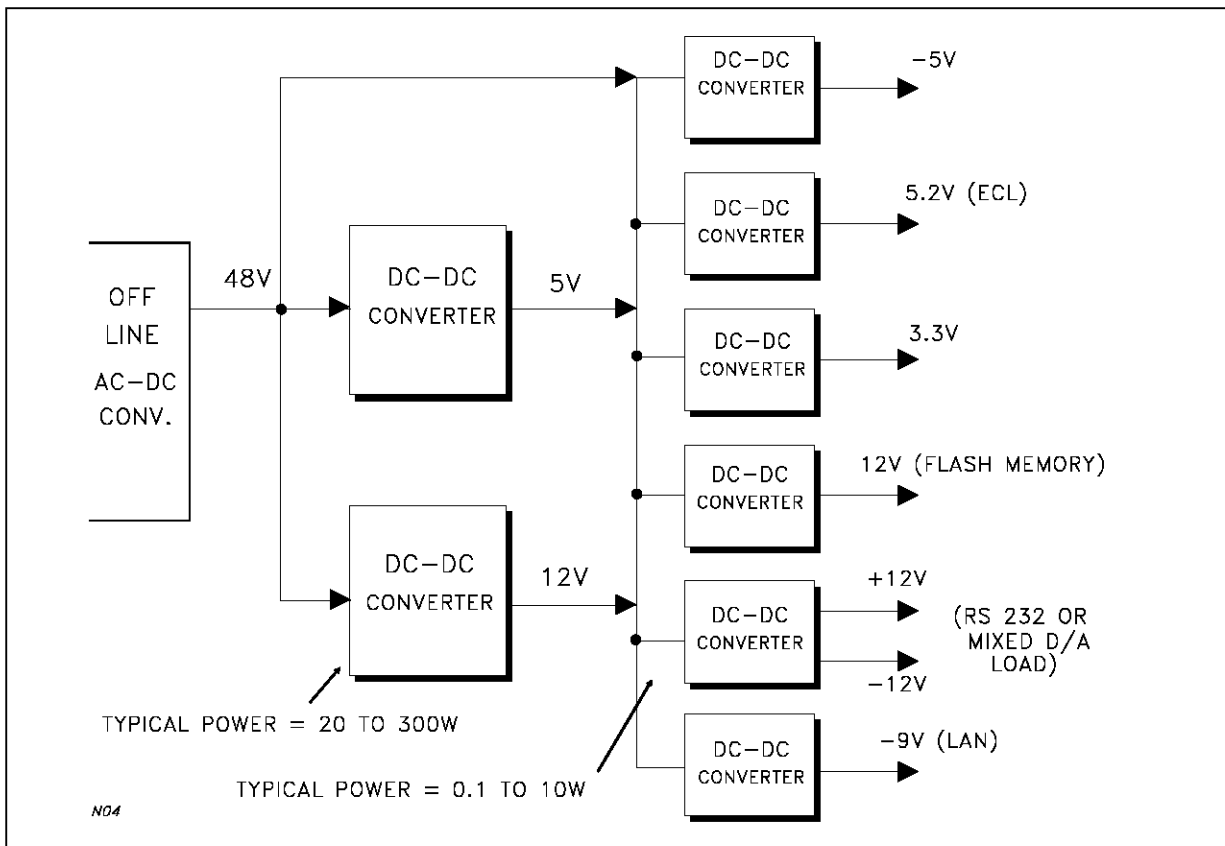

Information furnished is believed to be accurate and reliable. However, SGS-THOMSON Microelectronics assumes no responsibility for the consequences of use of such information nor for any infringement of patents or other rights of third parties which may result from its use. No license is granted by implication or otherwise under any patent or patent rights of SGS-THOMSON Microelectronics. Specification mentioned in this publication are subject to change without notice. This publication supersedes and replaces all information previously supplied. SGS-THOMSON Microelectronics products are not authorized for use as critical components in life support devices or systems without express written approval of SGS-THOMSON Microelectronics.

© 1994 SGS-THOMSON Microelectronics – All Rights Reserved

SGS-THOMSON Microelectronics GROUP OF COMPANIES
 Australia - Brazil - China - France - Germany - Hong Kong - Italy - Japan - Korea - Malaysia - Malta - Morocco - The Netherlands - Singapore - Spain - Sweden - Switzerland - Taiwan - Thailand - United Kingdom - U.S.A.



LittleDiode supplies new, hard to find or obsolete electronic components and semiconductors all over the world.

With over two million different components listed you are sure to find the part you need.

Feel free to visit us today at our online store:

LittleDiode.com

Looking forward to providing you with the best possible service.