

AN6408SA

Digital Cordless Telephone (PHS) IF Amplifier IC

Overview

As cordless telephones are now widely used, the trend is toward higher frequency and digital technology to accommodate for more channels and better speech quality. The AN6408SA is a best PHS IF amplifier IC satisfying these technical demands. It supports 300 MHz input.

Features

- Input frequency: Up to 300MHz
- RSSI dynamic range: 80dB
- Low current consumption: $I_{CC} = 5.9\text{mA}$
- Operating supply voltage range: 2.7 to 5V

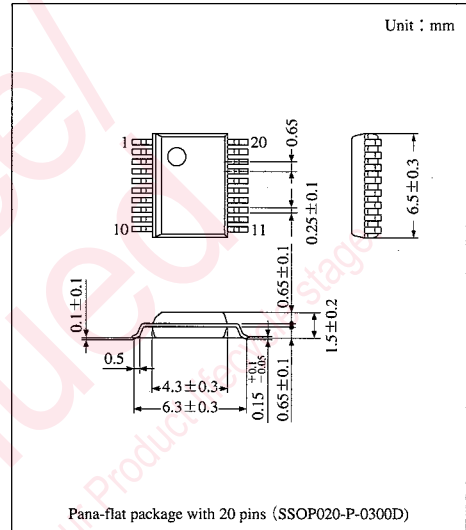

Block Diagram

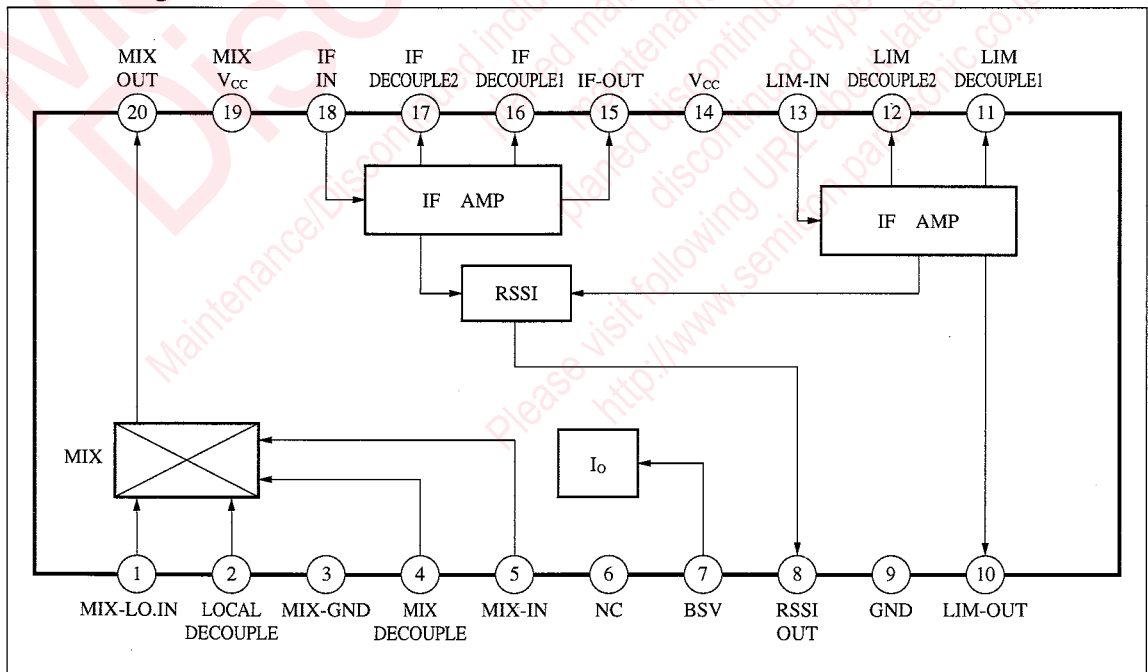

Mobile
Communication

■ Absolute Maximum Ratings (Ta=25°C)

Parameter	Symbol	Rating	Unit
Supply voltage	V _{CC}	5.5	V
Supply current	I _{CC}	8.0	mA
Power dissipation	P _D	44.0	mW
Operating ambient temperature	T _{opr}	-10 to +60	°C
Storage temperature	T _{stg}	-55 to +125	°C

Note) Protect from electrostatic discharge (see Usage Notes).

■ Operating Supply Voltage Range

Parameter	Symbol	Range
Operating supply voltage range	V _{CC}	2.7 to 5.0V

■ Electrical Characteristics (Ta=25±2°C)

Parameter	Symbol	Condition	min	typ	max	Unit
Current consumption	I _{CC}	With no signal	4.4	5.9	7.4	mA
Current consumption (at BS)	I _{CBS}	With no signal, SW1, 2=b	—	1.5	2.0	mA
IF-amp. voltage gain	G _{IF}	V _{I2} =50dBμ, G _{IF} =V _{IF} -V _{I2}	27	30	33	dB
LIM-amp. voltage gain	G _{LIM}	V _{I3} =30dBμ, G _{LIM} =V _{LM} -V _{I3}	51	54	57	dB
LIM-amp. max output amplitude	V _{LIM}	V _{I3} =70dBμ, V _{LIM} =V _{LM}	0.27	0.34	0.41	V _{P-P}
RSSI output voltage (1)	V _{S(1)}	V _{I2} =0dBμ, SW3, 4=b	—	0.4	0.6	V
RSSI output voltage (2)	V _{S(2)}	V _{I2} =115dBμ, SW3,4=b	1.8	2.1	2.4	V
Level detection ref. input	V _{IS}	V _{S(VIS)} = V _{I2} as V _{S(1)} + 0.15V SW3, 4=b	42	47	52	dBμ
Level detection output gradient	D _S	D _S = V _{S(VIS+60dBμ)} - V _{S(VIS)} SW3, 4=b	1.05	1.35	1.65	V
Level detection output gradient (1)	ΔD _{S(1)}	ΔD _{S(1)} = 5{V _{S(VIS+12dBμ)} - V _{S(VIS)} }/D _S SW3, 4=b	0.7	—	1.3	—
Level detection output gradient (2)	ΔD _{S(2)}	ΔD _{S(2)} = 5{V _{S(VIS+24dBμ)} - V _{S(VIS+12dBμ)} }/D _S SW3, 4=b	0.7	—	1.3	—
Level detection output gradient (3)	ΔD _{S(3)}	ΔD _{S(3)} = 5{V _{S(VIS+36dBμ)} - V _{S(VIS+24dBμ)} }/D _S SW3, 4=b	0.8	—	1.4	—
Level detection output gradient (4)	ΔD _{S(4)}	ΔD _{S(4)} = 5{V _{S(VIS+48dBμ)} - V _{S(VIS+36dBμ)} }/D _S SW3, 4=b	0.6	—	1.2	—
Level detection output gradient (5)	ΔD _{S(5)}	ΔD _{S(5)} = 5{V _{S(VIS+60dBμ)} - V _{S(VIS+48dBμ)} }/D _S SW3, 4=b	0.6	—	1.2	—
MIX conversion gain	G _{MIX}	V _{I1} = 70dBμ, G _{MIX} = V _{MX} - V _{I1} + 3dB	16.5	19.5	22.5	dB
MIX max output voltage	V _{MIX}	V _{I1} = 110dBμ, V _{MIX} = V _{MX} + 3dB	105	—	—	dBμ

Note) Unless otherwise specified, V_{CC}=3.0V, SW1, 2, 3, 4=a
 V_{I1}:f=243.95MHz, 50Ω output impedance
 V_{L0}:f=101dBμ, f=233.15MHz, 50Ω output impedance
 V_{I2}:f=10.8MHz, 50Ω output impedance
 V_{I3}:f=10.8MHz, 50Ω output impedance
 V_{MX}, V_{IF}, and V_{LM} were measured with a high-impedance voltmeter. V_S was measured with a digital voltmeter.

■ Characteristics Curve

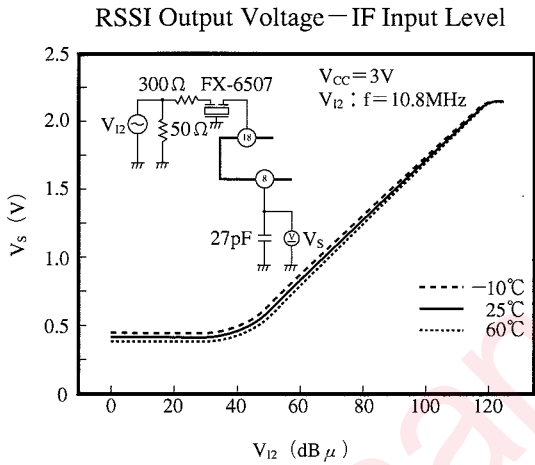

The characteristics shown are design values for reference only (not guaranteed)

■ Application Circuit

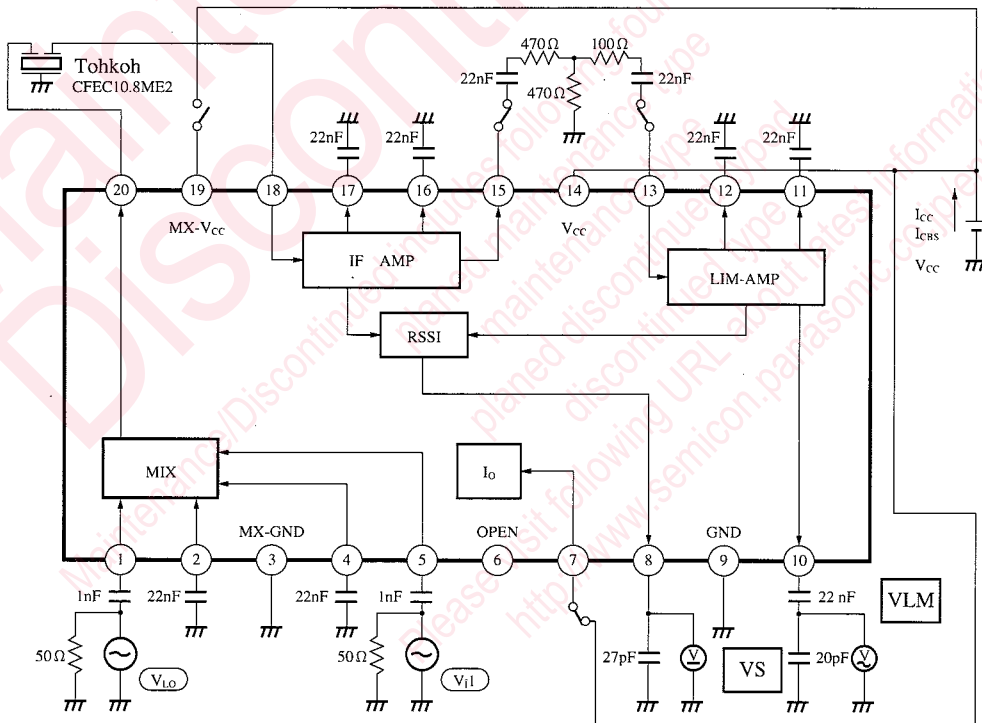

Mobile
Communication

Pin Descriptions

Pin No.	Description	Pin No.	Description
1	LOCAL - in	11	LIM - decouple1
2	LOCAL - decouple	12	LIM - decouple2
3	MIX - GND	13	LIM - in
4	MIX - decouple	14	V _{cc}
5	MIX - in	15	IF - out
6	NC	16	IF - decouple1
7	BSV	17	IF - decouple2
8	RSSI - out	18	IF - in
9	GND	19	MIX - V _{cc}
10	LIM - out	20	MIX - out

Usage Note

Protect from electrostatic discharge as follows
: (measured with C=200pF, and R=0Ω)

(The following are design values for reference only.)

Pin No.	Positive breakdown level (V)	Pin No.	Positive breakdown level (V)
1	130	8	180
2	180	10	180
4	180	11	180
5	180	19	200
6	170	20	210
7	170		

Request for your special attention and precautions in using the technical information and semiconductors described in this book

- (1) If any of the products or technical information described in this book is to be exported or provided to non-residents, the laws and regulations of the exporting country, especially, those with regard to security export control, must be observed.
- (2) The technical information described in this book is intended only to show the main characteristics and application circuit examples of the products. No license is granted in and to any intellectual property right or other right owned by Panasonic Corporation or any other company. Therefore, no responsibility is assumed by our company as to the infringement upon any such right owned by any other company which may arise as a result of the use of technical information described in this book.
- (3) The products described in this book are intended to be used for standard applications or general electronic equipment (such as office equipment, communications equipment, measuring instruments and household appliances).
Consult our sales staff in advance for information on the following applications:
 - Special applications (such as for airplanes, aerospace, automobiles, traffic control equipment, combustion equipment, life support systems and safety devices) in which exceptional quality and reliability are required, or if the failure or malfunction of the products may directly jeopardize life or harm the human body.
 - Any applications other than the standard applications intended.
- (4) The products and product specifications described in this book are subject to change without notice for modification and/or improvement. At the final stage of your design, purchasing, or use of the products, therefore, ask for the most up-to-date Product Standards in advance to make sure that the latest specifications satisfy your requirements.
- (5) When designing your equipment, comply with the range of absolute maximum rating and the guaranteed operating conditions (operating power supply voltage and operating environment etc.). Especially, please be careful not to exceed the range of absolute maximum rating on the transient state, such as power-on, power-off and mode-switching. Otherwise, we will not be liable for any defect which may arise later in your equipment.
 - Even when the products are used within the guaranteed values, take into the consideration of incidence of break down and failure mode, possible to occur to semiconductor products. Measures on the systems such as redundant design, arresting the spread of fire or preventing glitch are recommended in order to prevent physical injury, fire, social damages, for example, by using the products.
- (6) Comply with the instructions for use in order to prevent breakdown and characteristics change due to external factors (ESD, EOS, thermal stress and mechanical stress) at the time of handling, mounting or at customer's process. When using products for which damp-proof packing is required, satisfy the conditions, such as shelf life and the elapsed time since first opening the packages.
- (7) This book may be not reprinted or reproduced whether wholly or partially, without the prior written permission of our company.



LittleDiode supplies new, hard to find or obsolete electronic components and semiconductors all over the world.

With over two million different components listed you are sure to find the part you need.

Feel free to visit us today at our online store:

LittleDiode.com

Looking forward to providing you with the best possible service.