

AN6401NFA

Pager Direct Conversion FSK Demodulator Base-Band IC

Overview

The AN6401NFA is a base-band IC supporting direct conversion FSK demodulation for pagers.

Features

- Low current consumption : V_{CC1} current consumption $I_{CC1} = 510 \mu A$ ($V_{CC1} = 2.0V$), V_{CC2} current consumption $I_{CC2} = 330 \mu A$ ($V_{CC2} = 1.4V$)
- Battery saving function : current consumption is less than $1 \mu A$ at BS
- Incorporating two regulator circuits (REG1 and REG2 : 1.05 V).

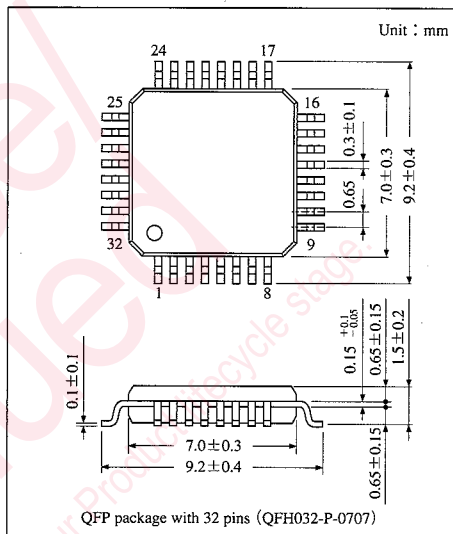

Block Diagram

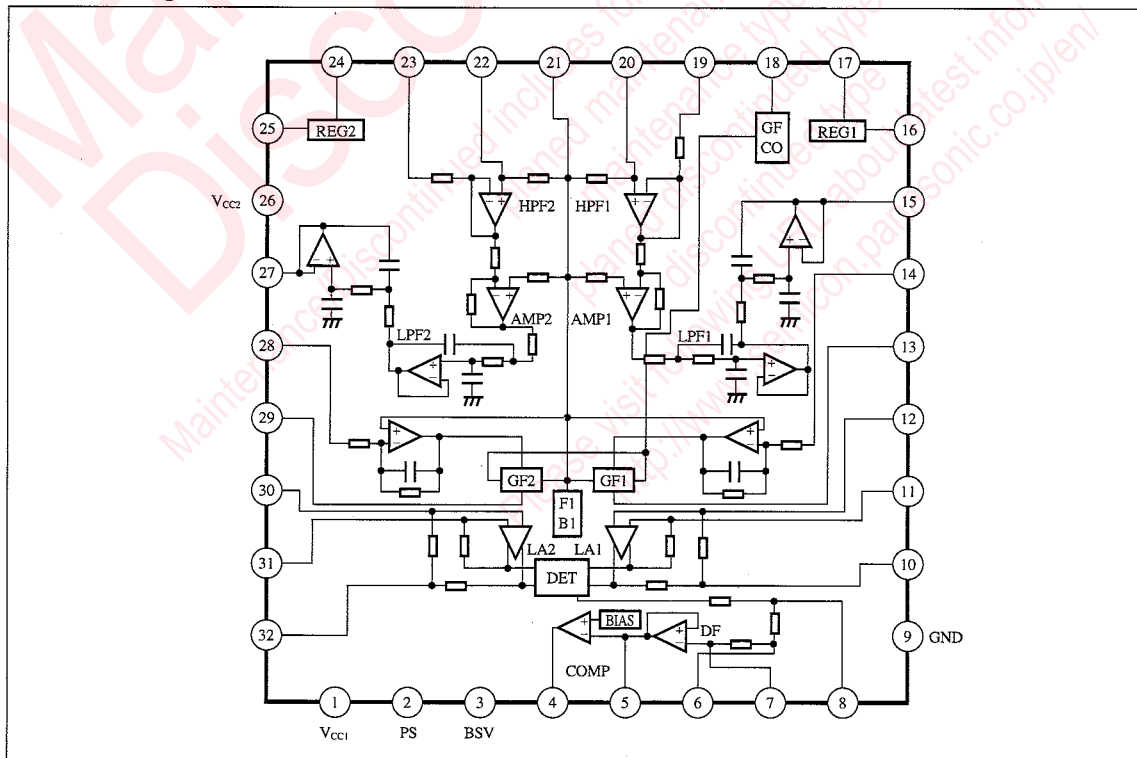

Mobile
Communication

■ Absolute Maximum Ratings (Ta = 25°C)

Parameter	Symbol	Rating	Unit
Supply voltage	V _{CC}	4	V
Supply current	I _{CC}	5	mA
Power dissipation (Ta = 75°C)	P _D	20 (Ta = 75°C)	mW
Operating ambient temperature	T _{opr}	-20 to +70	°C
Storage temperature	T _{stg}	-55 to +125	°C

■ Operating Supply Voltage Range

Parameter	Symbol	Range
Operating supply voltage range	V _{CC1}	1.8 to 4V
	V _{CC2}	0.9 to 1.6V

■ Electrical Characteristics (V_{CC1} = 2.0V, V_{CC2} = 1.4V, Ta = 25 ± 2°C)

Parameter	Symbol	Condition	min	typ	max	Unit
V _{CC1} current consumption (operational)	I ₁		385	510	635	μA
V _{CC1} current consumption (at BSV)	I _{1(BS)}		—	0	1.0	μA
V _{CC2} current consumption (operational)	I ₂		250	330	410	μA
V _{CC2} current consumption (at PS)	I _{2(PS)}		—	0	1.0	μA
REG1 output voltage	V _{REG1}		1.00	1.05	1.10	V
REG2 output voltage	V _{REG2}		1.00	1.05	1.10	V
Channel filter F. characteristics F1b	V _{F1b}	V ₁₁ = -40dBs, f ₁₁ = 4kHz	-33.5	-31.0	-28.5	dBs
Channel filter F. characteristics F2b	V _{F2b}	V ₁₂ = -40dBs, f ₁₂ = 4kHz	-33.5	-31.0	-28.5	dBs
Channel filter F. characteristics F1c	V _{F1c}	V ₁₁ = -40dBs, f ₁₁ = 25kHz	—	—	-73	dBs
Channel filter F. characteristics F2c	V _{F2c}	V ₁₂ = -40dBs, f ₁₂ = 25kHz	—	—	-73	dBs
Data demodulator characteristics (High)	V _{4H}	V ₁₁ = V ₁₂ = -40dBs f ₁₁ = f ₁₂ = 4kHz θ ₁₁ = θ ₁₂ - π/2	1.8	—	—	V
Data demodulator characteristics (Low)	V _{4L}	V ₁₁ = V ₁₂ = -40dBs f ₁₁ = f ₁₂ = 4kHz θ ₁₁ = θ ₁₂ + π/2	—	—	0.2	V

Note) 0dBs = 775mVrms

■ Electrical Characteristics (design values for reference) (V_{CC1} = 2.0V, V_{CC2} = 1.4V, Ta = 25 ± 2°C)

Parameter	Symbol	Condition	min	typ	max	Unit
Channel filter F. characteristics F1a	V _{F1a}	V ₁₁ = -40dBs, F ₁₁ = 1kHz	—	-30.5	—	dBs
Channel filter F. characteristics F2a	V _{F2a}	V ₁₂ = -40dBs, F ₁₂ = 1kHz	—	-30.5	—	dBs
Channel filter F. characteristics F1d	V _{F1d}	V ₁₁ = -40dBs, F ₁₁ = 50kHz	—	—	-73	dBs
Channel filter F. characteristics F2d	V _{F2d}	V ₁₂ = -40dBs, F ₁₂ = 50kHz	—	—	-73	dBs
Data duty characteristics	V _D	$VD = \frac{V_{SH} + V_{SL}}{2} - V_{SC}$ V ₁₃ = V ₁₄ = -40dBs f ₁₃ = f ₁₄ = 4kHz V _{SH} : θ ₁₃ = θ ₁₄ - π/2 V _{SL} : θ ₁₃ = θ ₁₄ + π/2 V _{SC} : V ₄ with H and L exchanged	—	0	—	mV

■ Pin Descriptions

Pin No.	Symbol	Description	Pin No.	Symbol	Description
1	V _{CC1}	Supply voltage (1)	17	RG1	Regulator (1) voltage detection
2	PS	Power saving signal input	18	GFC	Gyrator filter control
3	BSV	Battery saving signal input	19	H1O	Ch1 2nd HPF output
4	NRZ	Demodulator data output	20	H1I	Ch1 2nd HPF input
5	DFO	Data filter output	21	FBI	Filter bias output
6	DF2	Data filter input (2)	22	H2I	Ch2 2nd HPF input
7	DF3	Data filter input (3)	23	H2O	Ch2 2nd HPF output
8	DF1	Data filter input (1)	24	RG2	Regulator (2) voltage detection
9	GND	Ground	25	R2C	Regulator (2) voltage control
10	L1F	Ch1 limiter amp. feedback	26	V _{CC2}	Supply voltage (2)
11	L1R	Ch1 limiter amp. reference	27	F2O	Ch2 4th LPF output
12	L1I	Ch1 limiter amp. input	28	F2I	Ch2 1st LPF input
13	G1O	Ch1 gyrator filter output	29	G2O	Gyrator filter output
14	F1I	Ch1 1st LPF input	30	L2I	Ch2 limiter amp. input
15	F1O	Ch1 4th LPF output	31	L2R	Ch2 limiter amp. reference
16	R1C	Regulator (1) voltage control	32	L2F	Ch2 limiter amp. feedback

Request for your special attention and precautions in using the technical information and semiconductors described in this book

- (1) If any of the products or technical information described in this book is to be exported or provided to non-residents, the laws and regulations of the exporting country, especially, those with regard to security export control, must be observed.
- (2) The technical information described in this book is intended only to show the main characteristics and application circuit examples of the products. No license is granted in and to any intellectual property right or other right owned by Panasonic Corporation or any other company. Therefore, no responsibility is assumed by our company as to the infringement upon any such right owned by any other company which may arise as a result of the use of technical information described in this book.
- (3) The products described in this book are intended to be used for standard applications or general electronic equipment (such as office equipment, communications equipment, measuring instruments and household appliances).
Consult our sales staff in advance for information on the following applications:
 - Special applications (such as for airplanes, aerospace, automobiles, traffic control equipment, combustion equipment, life support systems and safety devices) in which exceptional quality and reliability are required, or if the failure or malfunction of the products may directly jeopardize life or harm the human body.
 - Any applications other than the standard applications intended.
- (4) The products and product specifications described in this book are subject to change without notice for modification and/or improvement. At the final stage of your design, purchasing, or use of the products, therefore, ask for the most up-to-date Product Standards in advance to make sure that the latest specifications satisfy your requirements.
- (5) When designing your equipment, comply with the range of absolute maximum rating and the guaranteed operating conditions (operating power supply voltage and operating environment etc.). Especially, please be careful not to exceed the range of absolute maximum rating on the transient state, such as power-on, power-off and mode-switching. Otherwise, we will not be liable for any defect which may arise later in your equipment.
 - Even when the products are used within the guaranteed values, take into the consideration of incidence of break down and failure mode, possible to occur to semiconductor products. Measures on the systems such as redundant design, arresting the spread of fire or preventing glitch are recommended in order to prevent physical injury, fire, social damages, for example, by using the products.
- (6) Comply with the instructions for use in order to prevent breakdown and characteristics change due to external factors (ESD, EOS, thermal stress and mechanical stress) at the time of handling, mounting or at customer's process. When using products for which damp-proof packing is required, satisfy the conditions, such as shelf life and the elapsed time since first opening the packages.
- (7) This book may be not reprinted or reproduced whether wholly or partially, without the prior written permission of our company.



LittleDiode supplies new, hard to find or obsolete electronic components and semiconductors all over the world.

With over two million different components listed you are sure to find the part you need.

Feel free to visit us today at our online store:

LittleDiode.com

Looking forward to providing you with the best possible service.