

AN6227FHN

Single chip, transmission and reception IC for PDC

■ Overview

The AN6227FHN is a transmission and reception IC incorporating reception sleep function for a 1.5 GHz cellular telephone.

■ Features

- Reception sleep function built-in
- Ultra mini-type 4 mm × 5 mm leadless package
- Current consumption: At reception: 25 mA
At transmission: 3.2 mA

■ Applications

- Cellular telephone (1.5 GHz PDC)

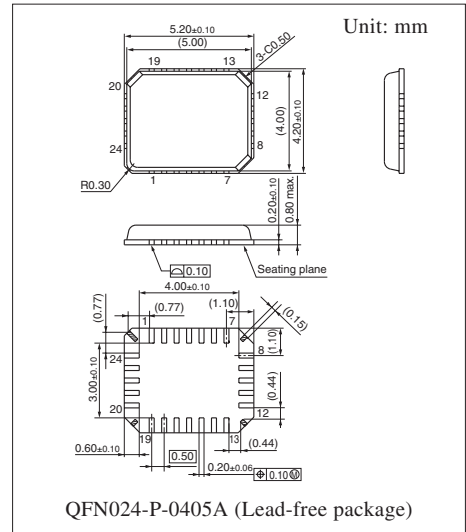

■ Block Diagram

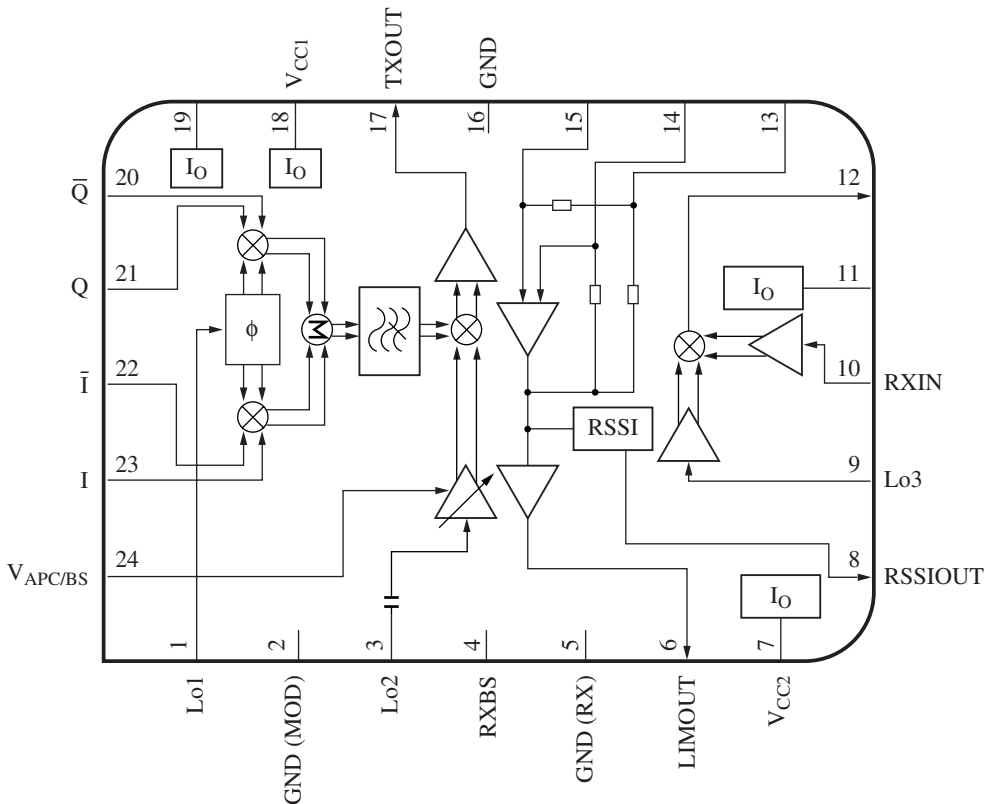

■ Pin Descriptions

Pin No.	Symbol	Description	Pin No.	Symbol	Description
1	TXLO1	TX local 1 input	13	LMDEC1	Limiter decouple 1
2	GNDMOD	TX modulator GND	14	LMDEC2	Limiter decouple 2
3	TXLO2	TX local 2	15	LMIN	Limiter input
4	RXBS	RXBS	16	GNDOUT	TX output GND
5	GNDRX	RX GND	17	TXOUT	TX output
6	LMOUT	Limiter output	18	VCCOUT	TX output V _{CC}
7	VCCLIM	V _{CC} limiter	19	VCCMOD	TX modulator V _{CC}
8	RSOUT	RSSI output	20	\bar{Q} -IN	\bar{Q} input
9	RXLOIN	RX local input	21	Q-IN	Q input
10	RXMXIN	RX mixer input	22	\bar{I} -IN	\bar{I} input
11	VCCMIX	Mixer V _{CC}	23	I-IN	I input
12	MXOUT	Mixer output	24	APC/BS	APC/BS

■ Absolute Maximum Ratings

Parameter	Symbol	Rating	Unit
Supply voltage	V _{CC}	4.2	V
Supply current	I _{CC}	60	mA
Power dissipation *2	P _D	125	mW
Operating ambient temperature *1	T _{opr}	-30 to +80	°C
Storage temperature *1	T _{stg}	-55 to +125	°C

Note) *1: Except for the operating ambient temperature and storage temperature, all ratings are for T_a = 25°C.

*2: P_D is the value at T_a = 80°C without a heatsink. Use this device within the range of allowable power dissipation referring to

"■ Technical Data • P_D — T_a curves of QFN024-P-0405".

■ Recommended Operating Range

Parameter	Symbol	Range	Unit
Supply voltage	V _{CC}	2.6 to 4.0	V

■ Electrical Characteristics at T_a = 25°C

Parameter	Symbol	Conditions	Min	Typ	Max	Unit
Current consumption (transmission) *1	I _{CCTX}	Lo1 = 178 MHz, -25 dBm Lo2 = 1 619 MHz, -18 dBm V _{APC} = 2.3 V	—	25	33	mA
Sleep current *1	I _{SLTX}	No signal, V _{APC/BS} ≤ 0.3 V	—	0	10	μA

■ Electrical Characteristics at T_a = 25°C (continued)

Parameter	Symbol	Conditions	Min	Typ	Max	Unit
Output level 1 * ¹	P _{O1}	Lo1 = 178 MHz, -25 dBm Lo2 = 1 607 MHz, -18 dBm V _{APC} = 2.3 V	-16	-13	—	dBm
Output level 2 * ¹	P _{O2}	Lo1 = 178 MHz, -25 dBm Lo2 = 1 631 MHz, -18 dBm V _{APC} = 2.3 V	-16	-13	—	dBm
Minimum output level * ¹	P _{min}	Lo1 = 178 MHz, -25 dBm Lo2 = 1 619 MHz, -18 dBm V _{APC} = 1.0 V	—	-50	-40	dBm
Current consumption (reception) * ²	I _{CCR_X}	No signal	—	3.2	4.5	mA
Reception sleep current * ²	I _{RXSLP}	No signal, RXBS ≤ 0.3 V	—	—	10	μA
Mixer conversion gain * ²	G _{MX}	V _{MI} = 60 dBμ, SW1 = b (refer to "■ Application Circuit Example"), Excludes the filter loss of -7 dB	20	23	26	dB
Mixer maximum output amplitude * ²	V _{MX}	V _{MI} = 105 dBμ, SW1 = b (refer to "■ Application Circuit Example"), Excludes the filter loss of -7 dB	100	106	—	dBμ
Limiter voltage gain * ²	G _{LM}	V _{LI} = 15 dBμ	80	85	90	dB
Limiter maximum output amplitude * ²	V _{LM}	V _{LI} = 80 dBμ, 450 kHz component	0.90	1.25	1.60	V[p-p]
RSSI output voltage 1 * ²	V _{S(1)}	V _{LI} = 0 dBμ	0	0.23	0.6	V
RSSI output voltage 2 * ²	V _{S(2)}	V _{LI} = 115 dBμ	2.31	2.6	2.91	V
RSSI reference output slope * ³	D _S	V _S (V _{IS}) = V _{S(1)} + 0.12 V D _S = V _S (V _{IS} + 75 dBμ) - V(V _{IS})	1.39	1.8	2.19	V
RSSI output slope variation 1 * ³	ΔD _{S(1)}	ΔD _{S(1)} = 5 { V _S (V _{IS} + 15 dBμ) - V _S (V _{IS}) } / D _S	0.75	1	1.25	—
RSSI output slope variation 2 * ³	ΔD _{S(2)}	ΔD _{S(2)} = 5 { V _S (V _{IS} + 30 dBμ) - V _S (V _{IS} + 15 dBμ) } / D _S	0.75	1	1.25	—
RSSI output slope variation 3 * ³	ΔD _{S(3)}	ΔD _{S(3)} = 5 { V _S (V _{IS} + 45 dBμ) - V _S (V _{IS} + 30 dBμ) } / D _S	0.75	1	1.25	—
RSSI output slope variation 4 * ³	ΔD _{S(4)}	ΔD _{S(4)} = 5 { V _S (V _{IS} + 60 dBμ) - V _S (V _{IS} + 45 dBμ) } / D _S	0.75	1	1.25	—
RSSI output slope variation 5 * ³	ΔD _{S(5)}	ΔD _{S(5)} = 5 { V _S (V _{IS} + 75 dBμ) - V _S (V _{IS} + 60 dBμ) } / D _S	0.75	1	1.25	—

Note) *1: V_{CC1} = 3.0 V, IQ signal amplitude: 0.18 V[p-p] (both phases), DC bias: 1.6 V, (π/4 QPSK-modulated [0000] continuous wave input.

Output frequency of P_{O1}: 1429.0025 MHz, output frequency of P_{O2}: 1453.0025 Hz, output frequency of P_{min}: 1441.0025 MHz.
Output level is measured with a spectrum analyzer.

Setting of a spectrum analyzer: SPAN = 20 kHz, RBW = 300 Hz, VBW = 30 Hz, ST = 5 s

(When inputting π/4 QPSK-modulated [0000] continuous wave as IQ signal, the frequency for P_{O1}, P_{O2} and P_{min} becomes Lo frequency plus IQ signal frequency, which leads to the above value.)

Lo input level is a setting value of signal source (output impedance 50 Ω) described in the "■ Application Circuit Example".

■ Electrical Characteristics at $T_a = 25^\circ\text{C}$ (continued)

Note) (continued)

*2: Unless otherwise specified: $V_{CC2} = 3.0\text{ V}$, $R_{XBS} = 2.5\text{ V}$ to 3.0 V , $SW1 = a$ (Refer to " Application Circuit Example").

$V_{LO3} = 90\text{ dB}\mu$; $f = 129.55\text{ MHz}$, V_{MI} : $f = 130\text{ MHz}$, V_{LI} : $f = 450\text{ kHz}$

(Input level of pin 15 is excluded the loss of the matching circuit and filter.)

V_{MX} and V_{LM} are measured in high impedance.

Lo input level is a setting value of signal source (output impedance $50\ \Omega$) described in the "■ Application Circuit Example".

*3: V_{IS} is the input level V_{LI} at which the RSSI output voltage becomes $V_{S(1)} + 0.12\text{ V}$.

• Design reference data

Unless otherwise specified, $V_{CC1} = 3.0\text{ V}$.

Lo input level is a setting value of signal source (output impedance $50\ \Omega$) described in the "■ Application Circuit Example".

Note) The characteristics listed below are theoretical values based on the IC design and are not guaranteed.

Parameter	Symbol	Conditions	Min	Typ	Max	Unit
Carrier leak suppression *1 (fLo2-fLo1)	CL	Lo1 = 178 MHz, -25 dBm Lo2 = 1619 MHz, -18dBm $V_{APC} = 2.3\text{ V}$	—	-35	-25	dBc
Image leak suppression *1	IL	Lo1 = 178 MHz, -25 dBm Lo2 = 1619 MHz, -18 dBm $V_{APC} = 2.3\text{ V}$	—	-35	-30	dBc
Proximity spurious suppression *1	DU	Lo1 = 178 MHz, -25 dBm Lo2 = 1619 MHz, -18 dBm $V_{APC} = 2.3\text{ V}$	—	-70	-65	dBc
Base band distortion suppression *1	BD	Lo1 = 178 MHz, -25 dBm Lo2 = 1619 MHz, -18 dBm $V_{APC} = 2.3\text{ V}$	—	-40	-30	dBc
Adjacent channel leak power suppression (30 kHz detuning) *2	BL1	Lo1 = 178 MHz, -25 dBm Lo2 = 1619 MHz, -18 dBm $V_{APC} = 2.3\text{ V}$	—	-45	-38	dBc
Adjacent channel leak power suppression (50 kHz detuning) *2	BL2	Lo1 = 178 MHz, -25 dBm Lo2 = 1619 MHz, -18 dBm $V_{APC} = 2.3\text{ V}$	—	-70	-60	dBc
Adjacent channel leak power suppression (100 kHz detuning) *2	BL3	Lo1 = 178 MHz, -25 dBm Lo2 = 1619 MHz, -18 dBm $V_{APC} = 2.3\text{ V}$	—	—	-65	dBc
APC variable width *1	L_{APC}	Lo1 = 178 MHz, -25 dBm Lo2 = 1619 MHz, -18 dBm $V_{APC} = 1.0\text{ V}$ to 2.3 V	30	37	45	dB
APC output level control sensitivity *1	S_{APC}	Lo1 = 178 MHz, -25 dBm Lo2 = 1619 MHz, -18 dBm $V_{APC} = 1.0\text{ V}/1.6\text{ V}$	37	46	55	dB/V
In-band output level deviation *1	ΔP	Lo1 = 178 MHz, -25 dBm Lo2 = 1607 MHz to 1631 MHz, -18 dBm, $V_{APC} = 2.3\text{ V}$	-1.5	—	+1.5	dB

■ Electrical Characteristics at $T_a = 25^\circ\text{C}$ (continued)

• Design reference data (continued)

Unless otherwise specified, $V_{CC1} = 3.0\text{ V}$.

Lo input level is a setting value of signal source (output impedance $50\ \Omega$) described in the "■ Application Circuit Example".

Note) The characteristics listed below are theoretical values based on the IC design and are not guaranteed.

Parameter	Symbol	Conditions	Min	Typ	Max	Unit
Modulation precision *3	EVM	Lo1 = 178 MHz, -25 dBm Lo2 = 1 619 MHz, -18 dBm $V_{APC} = 2.3\text{ V}$	—	2.0	3.5	%[rms]

Note) *1: IQ signal amplitude: 0.18 V[p-p] (both phases), DC bias: 1.6 V, $\pi/4$ QPSK-modulated [0000] continuous wave input.

Measure the suppression amount for output with a spectrum analyzer.

Setting of a spectrum analyzer: SPAN = 20 kHz, RBW = 300 Hz, VBW = 30 Hz, ST = 5 s

*2: IQ signal amplitude: 0.18 V[p-p] (both phases), DC bias: 1.6 V, $\pi/4$ QPSK-modulated [PN9] continuous wave input.

To be measured by a spectrum analyzer. (By using a leak power measurement function for an adjacent channel.)

Setting of a spectrum analyzer: SPAN = 250 kHz, RBW = 1 kHz, VBW = 1 kHz, ST = 2 s

*3: IQ signal amplitude: 0.18 V[p-p] (both phases), DC bias: 1.6 V, $\pi/4$ QPSK-modulated [PN9] continuous wave input.

The output level be measured by a spectrum analyzer. (By using a modulation precision measurement function.)

■ Terminal Equivalent Circuits

Pin No.	Equivalent circuit	Description	I/O
1		TXLO1: Input pin of quadrature modulator.	I
2		GNDMOD: GND pin of phase shifter and modulator. Make impedance low by widening the GND pattern.	—
3		TXLO2: Local input pin for up mixer.	I
4		RXBS: On/off control pin for reception block.	I

RXBS (V)	Reception block
0 to 0.3	Off
2.5 to 3	On

■ Terminal Equivalent Circuits (continued)

Pin No.	Equivalent circuit	Description	I/O
5		GNDRX: GND pin of reception system. Make impedance low by widening the GND pattern.	—
6		LMOUT: Output pin of limiter amplifier.	O
7		VCCLIM: V _{CC} pin for IF limiter amplifier RSSI.	—
8		RSOUT: RSSI output pin. DC potential corresponding to input signal level of limiter amplifier is outputted.	O
9		RXLOIN: Local input pin for reception down mixer.	I
10		RXMXIN: Input pin to 1st. IF amplifier. Input impedance is 2 kΩ.	I
11		VCCMIX: V _{CC} pin for reception down mixer.	—
12		MXOUT: Reception down-mixer output pin.	O

■ Terminal Equivalent Circuits (continued)

Pin No.	Equivalent circuit	Description	I/O			
13, 14		Pin 13: LMDEC1; Pin 14: LMDEC2: De-coupling pin for feedback of limiter amplifier. Connect an external capacitor to GND.	—			
15		LMIN: Limiter amplifier input pin. Input impedance is 2 kΩ.	I			
16		GNDOUT: GND pin for transmission up-mixer and RF output amplifier.	—			
17		TXOUT: RF output pin from output amplifier circuit.	O			
18		VCCOUT: V _{CC} pin for transmission up-mixer and RF output amplifier.	—			
19		VCCMOD: V _{CC} pin for phase shifter and quadrature modulator.	—			
20		\overline{Q} -IN: Q signal input pin. Relation between DC bias and amplitude is as follows:	I			
21		Q-IN: Q signal input pin. Relation between DC bias and amplitude is as follows:	I			
		<table border="1"> <thead> <tr> <th>DC bias (V)</th> <th>Amplitude (V[p-p])</th> </tr> </thead> <tbody> <tr> <td>1.6</td> <td>0.18</td> </tr> </tbody> </table> Input impedance is 100 kΩ or more.	DC bias (V)	Amplitude (V[p-p])	1.6	0.18
DC bias (V)	Amplitude (V[p-p])					
1.6	0.18					

Terminal Equivalent Circuits (continued)

Pin No.	Equivalent circuit	Description	I/O						
22		<p>\bar{I}-IN: \bar{I} signal input pin. Relation between DC bias and amplitude is as follows:</p> <table border="1"> <thead> <tr> <th>DC bias (V)</th> <th>Amplitude (V[p-p])</th> </tr> </thead> <tbody> <tr> <td>1.6</td> <td>0.18</td> </tr> </tbody> </table> <p>Input impedance is 100 kΩ or more.</p>	DC bias (V)	Amplitude (V[p-p])	1.6	0.18	I		
DC bias (V)	Amplitude (V[p-p])								
1.6	0.18								
23		<p>I-IN: I signal input pin. Relation between DC bias and amplitude is as follows:</p> <table border="1"> <thead> <tr> <th>DC bias (V)</th> <th>Amplitude (V[p-p])</th> </tr> </thead> <tbody> <tr> <td>1.6</td> <td>0.18</td> </tr> </tbody> </table> <p>Input impedance is 100 kΩ or more.</p>	DC bias (V)	Amplitude (V[p-p])	1.6	0.18	I		
DC bias (V)	Amplitude (V[p-p])								
1.6	0.18								
24		<p>APC/BC: Pin for use both as battery saving of transmission block and as power control of transmitting RF output. Control with the following conditions:</p> <table border="1"> <thead> <tr> <th>V_{APC} (V)</th> <th>Mode</th> </tr> </thead> <tbody> <tr> <td>0 to 0.3</td> <td>Off</td> </tr> <tr> <td>1.0 to V_{CC}</td> <td>On (APC control)</td> </tr> </tbody> </table> <p>Input impedance is 5 kΩ or more.</p>	V_{APC} (V)	Mode	0 to 0.3	Off	1.0 to V_{CC}	On (APC control)	I
V_{APC} (V)	Mode								
0 to 0.3	Off								
1.0 to V_{CC}	On (APC control)								

Technical Data

1. $P_D - T_a$ curves of QFN024-P-0405A

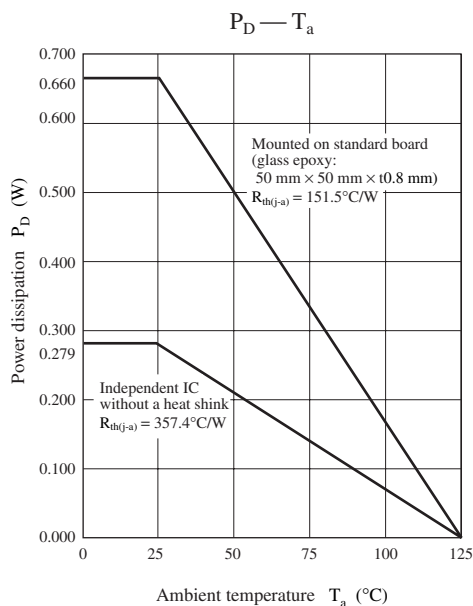

■ Technical Data (continued)

2. Main characteristics

APC control voltage characteristics

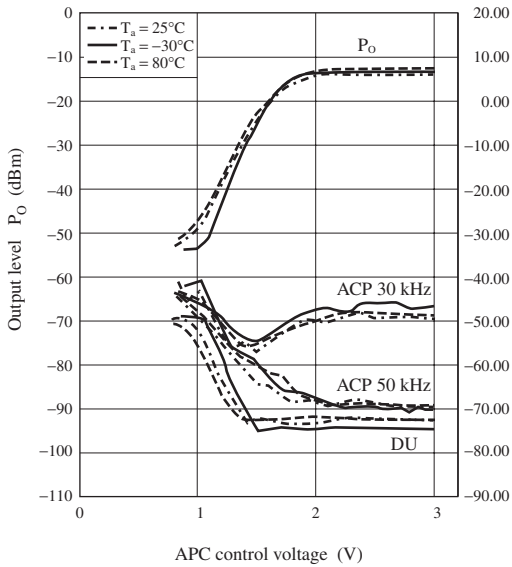

$V_{CC} = 3.0\text{ V}$, $T_a = -30^\circ\text{C}$, 25°C , 80°C ,
 $BS = V_{APC} = V_{AR}$
 Lo1: 178 MHz, -25 dBm
 Lo2: 1619 MHz, -18 dBm
 I, Q: 0.18 V[p-p] (both phases) 1.6 V_{DC},
 $\pi/4$, [0000] or using PN9 stages
 continuous wave.

Adjacent channel leak power suppression
 amount: ACP 30 kHz, ACP 50 kHz (dBc)
 Proximity spurious suppression amount:
 DU (dBc)

Mixer characteristic

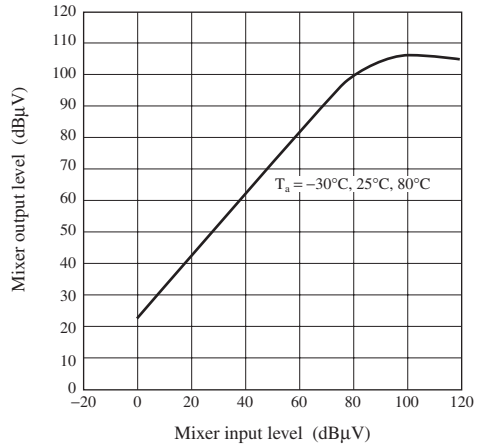

$V_{CC} = 3.0\text{ V}$, $T_a = -30^\circ\text{C}$, 25°C , 80°C
 Mixer in: 130 MHz
 Mixer out: 450 kHz
 Lo3 in: 129.55 MHz, 90 dBμV

Limiter amplifier characteristics

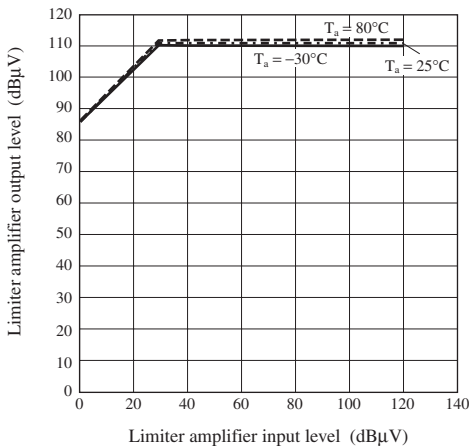

$V_{CC} = 3.0\text{ V}$, $T_a = -30^\circ\text{C}$, 25°C , 80°C ,
 $BS = 2.5\text{ V}$
 Limiter in: 450 MHz, Limiter out: 450 kHz

RSSI characteristic

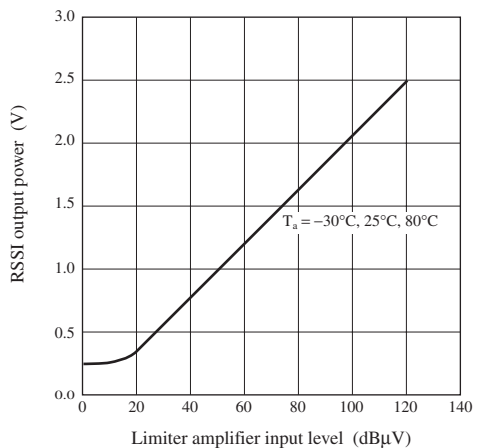

$V_{CC} = 3.0\text{ V}$, $T_a = -30^\circ\text{C}$, 25°C , 80°C ,
 $BS = 2.5\text{ V}$
 Limiter in: 450 MHz, Limiter out: 450 kHz

■ Application Circuit Example

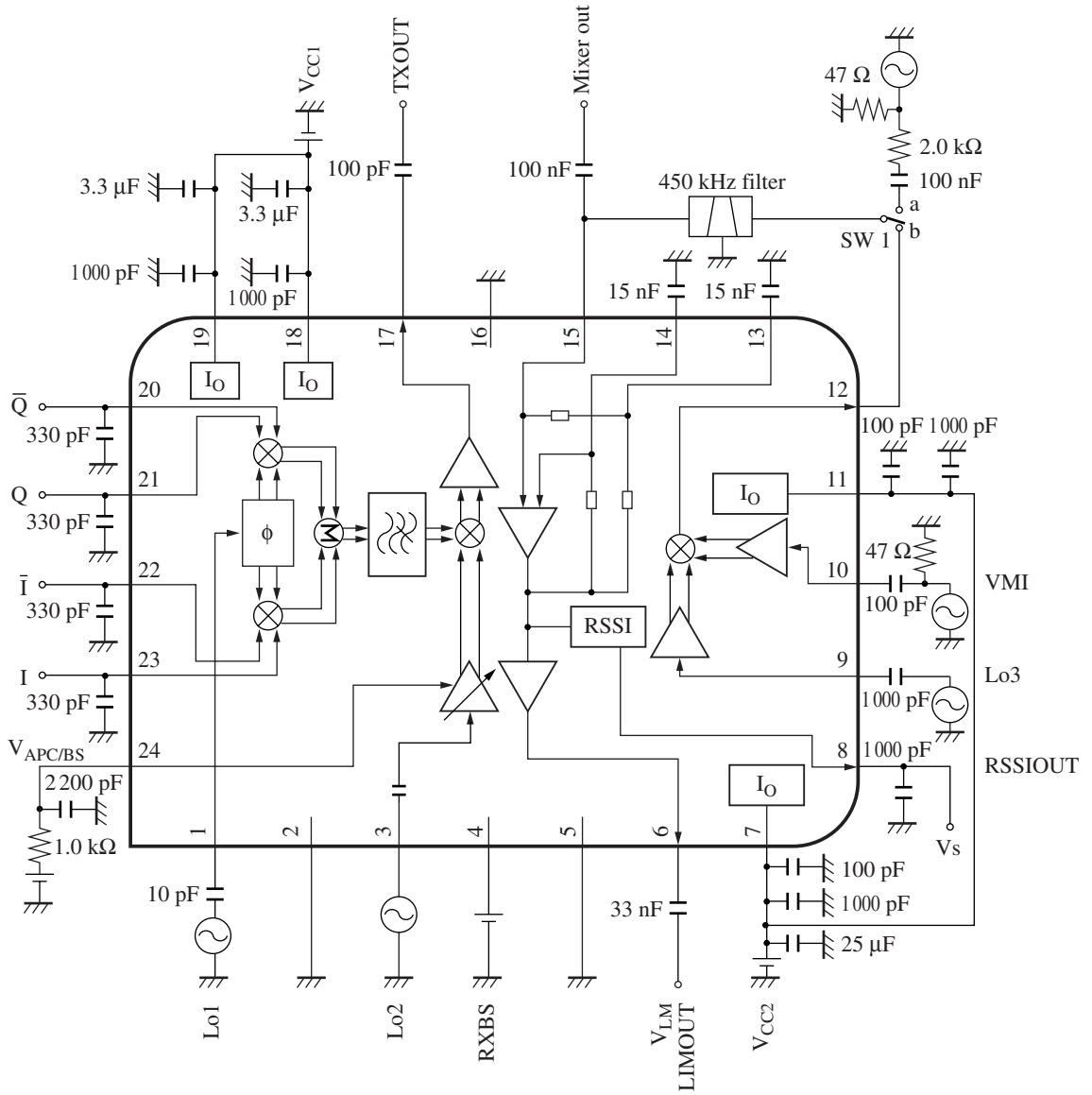

Request for your special attention and precautions in using the technical information and semiconductors described in this material

- (1) An export permit needs to be obtained from the competent authorities of the Japanese Government if any of the products or technologies described in this material and controlled under the "Foreign Exchange and Foreign Trade Law" is to be exported or taken out of Japan.
- (2) The technical information described in this material is limited to showing representative characteristics and applied circuits examples of the products. It neither warrants non-infringement of intellectual property right or any other rights owned by our company or a third party, nor grants any license.
- (3) We are not liable for the infringement of rights owned by a third party arising out of the use of the product or technologies as described in this material.
- (4) The products described in this material are intended to be used for standard applications or general electronic equipment (such as office equipment, communications equipment, measuring instruments and household appliances).
Consult our sales staff in advance for information on the following applications:
 - Special applications (such as for airplanes, aerospace, automobiles, traffic control equipment, combustion equipment, life support systems and safety devices) in which exceptional quality and reliability are required, or if the failure or malfunction of the products may directly jeopardize life or harm the human body.
 - Any applications other than the standard applications intended.
- (5) The products and product specifications described in this material are subject to change without notice for modification and/or improvement. At the final stage of your design, purchasing, or use of the products, therefore, ask for the most up-to-date Product Standards in advance to make sure that the latest specifications satisfy your requirements.
- (6) When designing your equipment, comply with the guaranteed values, in particular those of maximum rating, the range of operating power supply voltage, and heat radiation characteristics. Otherwise, we will not be liable for any defect which may arise later in your equipment.
Even when the products are used within the guaranteed values, take into the consideration of incidence of break down and failure mode, possible to occur to semiconductor products. Measures on the systems such as redundant design, arresting the spread of fire or preventing glitch are recommended in order to prevent physical injury, fire, social damages, for example, by using the products.
- (7) When using products for which damp-proof packing is required, observe the conditions (including shelf life and amount of time let standing of unsealed items) agreed upon when specification sheets are individually exchanged.
- (8) This material may be not reprinted or reproduced whether wholly or partially, without the prior written permission of Matsushita Electric Industrial Co., Ltd.



LittleDiode supplies new, hard to find or obsolete electronic components and semiconductors all over the world.

With over two million different components listed you are sure to find the part you need.

Feel free to visit us today at our online store:

LittleDiode.com

Looking forward to providing you with the best possible service.