

AN6175K

Hands-free Speech Network IC

■ Overview

The AN6175K is a speech network IC incorporating a hands-free function. It provides for a high-quality hands-free telephone or handset telephone. The hands-free telephone function(HF)includes :

- MIC amplifier capable of mute and gain control
- Background noise monitoring
- Voice switching attenuation control
- Symmetrical transmitter/receiver attenuators
- Dynamic loudspeaker amplifier

The handset telephone function(HF)includes:

- Automatic pad capable of detecting transmission distance
- MIC amplifier
- Receiver preamplifier
- Dynamic loudspeaker amplifier

■ Features

- Provides all the functions required of a hands-free or handset telephone.
- Can operate on line voltage (requiring no external power supply).
- Consumes minimal current.
- Provides for an external filter ensuring a wide range of howling suppression.
- Mute mode for hands-free operation
- Background noise monitoring to improve transmission quality
- 100 mW loudspeaker output (at $I_L=100\text{mA}$)
- Built-in power supply and low-voltage regulator
- DIP package with 42-pins or QFH package with 44-pins

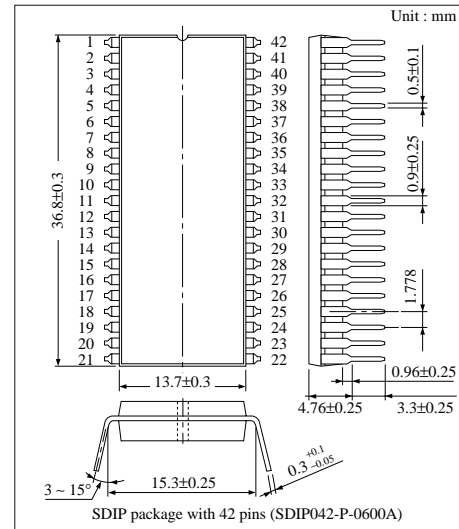

■ Block Diagram

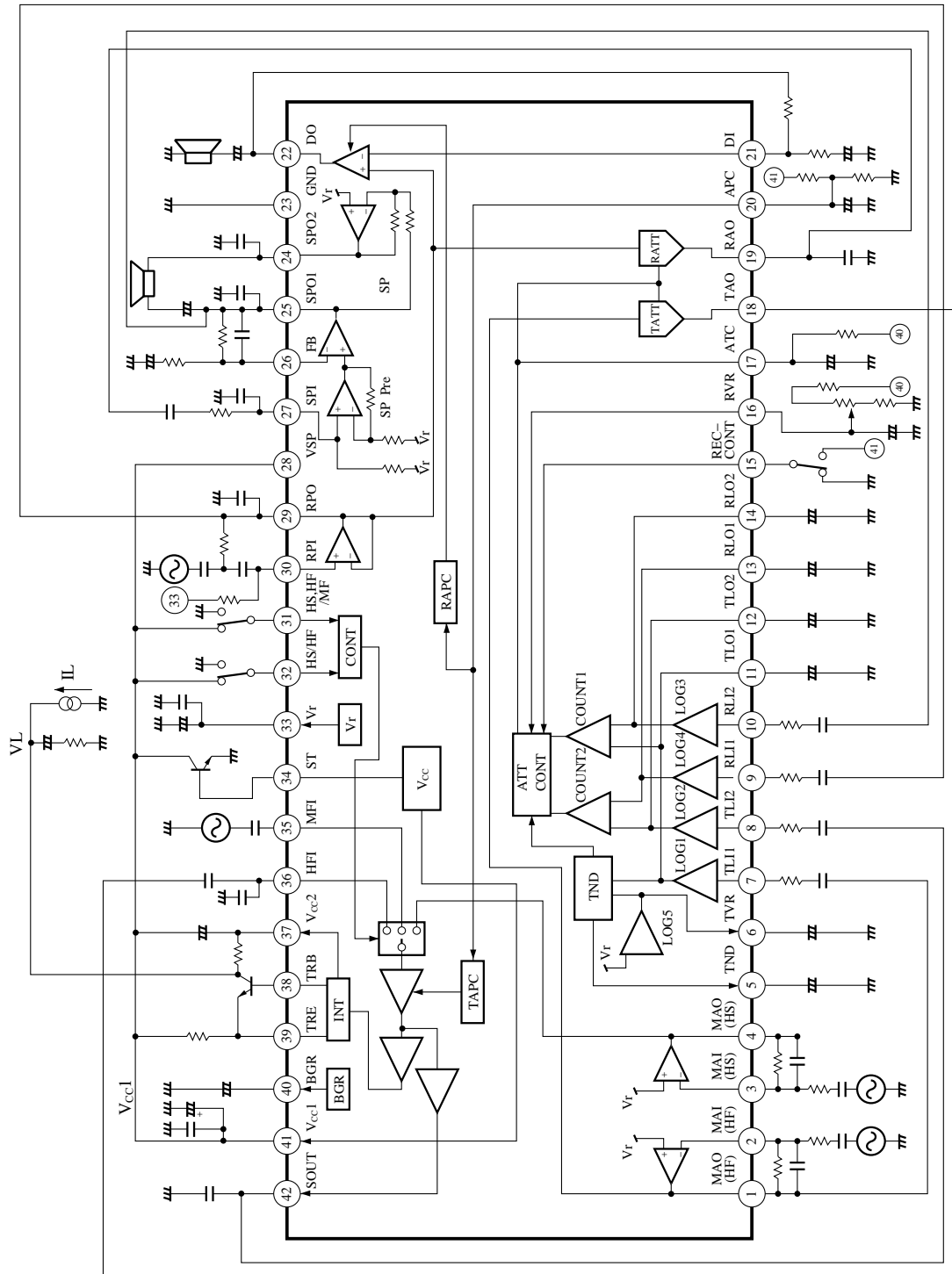

■ Pin Descriptions

Pin No.	Symbol	Description	Pin No.	Symbol	Description
1	MAO (HF)	MIC amp. output (hands-free mode)	22	DO	Receiver amp. output
2	MAI (HF)	MIC amp. input (hands-free mode)	23	GND	Ground
3	MAI (HS)	MIC amp. input (handset mode)	24	SPO2	Loudspeaker amp. (2) output
4	MAO (HS)	MIC amp. output (handset mode)	25	SPO1	Loudspeaker amp. (1) output
5	TND	Hands-free mode transmission noise detection	26	FB	Loudspeaker amp. input (-)
6	TVR	Noise detection reference	27	SPI	Loudspeaker amp. input (+)
7	TLI1	LOG amp. (1) input (from MIC amp. output)	28	VSP	Loudspeaker amp. power input
8	TLI2	LOG amp. (2) input (from hands-free control output)	29	RPO	Receiver preamp. output
9	RLI1	LOG amp. (4) input (from receiver preamp. output)	30	RPI	Receiver preamp. input
10	RLI2	LOG amp. (3) input (from loudspeaker amp. output)	31	HS, HF/MF	Mode switching (handset or hands-free/MF)
11	TLO1	LOG amp. (1) output	32	HS/HF	Mode switching (handset/hands-free)
12	TLO2	LOG amp. (2) output	33	Vr	Reference for handset or hands-free mode
13	RLO1	LOG amp. (3) output	34	ST	To the base of the power supply transistor
14	RLO2	LOG amp. (4) output	35	MFI	MF input
15	REC-CONT	Receiver switching (hands-free mode)	36	HFI	From transmitter att. output (hands-free mode)
16	RVR	Receiver att. gain control	37	V _{CC2}	Transmission amp. AC impedance setting
17	ATC	Receiver att. switching control	38	TRB	To the base of the transmission transistor
18	TAO	Transmitter att. output (hands-free mode)	39	TRE	To the emitter of the transmission transistor
19	RAO	Receiver att. output (hands-free mode)	40	BGR	Band-gap ref. voltage output
20	APC	Auto. PAD current control (handset mode, MF)	41	V _{CC1}	Power output to the handset and hands-free circuits
21	DI	Receiver amp. input (-)	42	SOUT	Hands-free control output

■ Absolute Maximum Ratings (T_a=25°C)

Parameter	Symbol	Rating	Unit
Supply voltage	V _{CC2}	12.0	V
Supply current	I _L	120	mA
Power dissipation ^{Note)}	P _D	1016	mW
Operating ambient temperature	T _{opr}	-20 to + 75	°C
Storage temperature	T _{stg}	-55 to + 150	°C

Note) In an open condition with T_a=25°C

■ Electrical Characteristics (Ta=25±2°C)

Parameter	Symbol	Condition	min	typ	max	Unit
HS power supply						
HS mode line voltage (1)	V _{LS1}	SW1,2 : a I _L = 20mA, V _L voltage	3.6	4.0	4.4	V
HS mode line voltage (2)	V _{LS2}	SW1/2 : a/a I _L = 120mA, V _L voltage	9.5	10.5	11.5	V
HS mode V _{CC2} voltage (1)	V _{CS21}	SW1/2 =a/a, I _L = 20mA, DC voltage at pin37	3.3	3.7	4.1	V
HS mode V _{CC2} voltage (2)	V _{CS22}	SW1/2 =a/a, I _L = 120mA, DC voltage at pin37	8.3	9.3	10.3	V
HS mode V _{CC1} voltage (1)	V _{CS11}	SW1/2 =a/a, I _L = 20mA, DC voltage at pin41	1.6	2.0	2.4	V
HS mode V _{CC1} voltage (2)	V _{CS12}	SW1/2 =a/a, I _L = 120mA, DC voltage at pin41	4.4	4.8	5.2	V
HF power supply						
HF mode line voltage (1)	V _{LF1}	SW1/2=a/b, I _L = 20mA, V _L voltage	3.6	4.0	4.4	V
HF mode line voltage (2)	V _{LF2}	SW1/2=a/b, I _L = 120mA, V _L voltage	9.5	10.5	11.5	V
HF mode V _{CC2} voltage (1)	V _{CF21}	SW1/2=a/b, I _L = 20mA, DC voltage at pin37	3.3	3.7	4.1	V
HF mode V _{CC2} voltage (2)	V _{CF22}	SW1/2=a/b, I _L = 120mA, DC voltage at pin37	8.3	9.3	10.3	V
HF mode V _{CC1} voltage (1)	V _{CF11}	SW1/2=a/b, I _L = 20mA, DC voltage at pin41	1.6	2.0	2.4	V
HF mode V _{CC1} voltage (2)	V _{CF12}	SW1/2=a/b, I _L = 120mA, DC voltage at pin41	4.4	4.8	5.2	V
HS transmitter						
Trans. amp. gain	GHS	Vin1= -30dBm	27	29	31	dB
Trans. amp. distortion	THS	Vin1= -30dBm	—	0.3	2.0	%
Trans. amp. max output	VHS	THS= 5%	-0.5	2.5	—	dBm
Trans. amp. noise	NHS	R _g = 2kΩ with a CCITT filter	—	—	-65	dBm
Trans. level auto. PAD	APS	Gain Difference with Vin1= -30dBm, I _L = 20 to 120mA	4	6	8	dB
MF trans. amp. gain	GMF	Vin2= -30dBm	27	29	31	dB
MF trans. amp. distortion	TMF	Vin2= -30dBm	—	0.3	2.0	%
MF trans. amp. max output	VMF	TMF= 5%	0	3.0	—	dBm
MF trans. amp. auto. PAD	APMF	Gain Difference with Vin2= -30dBm, I _L = 20 to 120mA	4	6	8	dB
HS receiver						
Rec. amp. gain	GHR	Vin3= -35dBm	17	19	21	dB
Rec. amp. distortion	THR	Vin3= -35dBm	—	1.5	5	%
Rec. amp. max output	VHR	THR= 5%	-10	-7	—	dBm
Rec. amp. noise	NHR	R _g =2kΩ with a CCITT filter	—	—	-75	dBm
Rec. amp. auto. PAD	APR	Gain Difference with Vin3= -35dBm, I _L = 20 to 120mA	4	6	8	dB

Note: Unless otherwise specified, I_L=20 mA and f_{in}=1 kHz.

■ Electrical Characteristics (cont.) (Ta=25±2°C)

Parameter	Symbol	Condition	min	typ	max	Unit
HF transmitter						
Trans. gain (1)	G _{FS1}	Vin4= -65dBm I _L =20mA	57	60	63	dB
Trans. gain (2)	G _{FS2}	Vin4= -65dBm I _L =120mA	63	66	69	dB
Trans. noise	N _{FS}	R _g =2kΩ, I _L =20mA with a CCITT filter	—	—	-58	dBm
Trans. att. gain (1)	G _{TA MAX1}	Vin4= -60dBm I _L =20mA	28	31	34	dB
Trans. att. gain range (1)	G _{TA MIN1}	Vin4= -60dBm I _L =20mA	45	48	—	dB
Trans. att. idling gain (1)	G _{TA IDL1}	Vin4= -60dBm I _L =20mA	1	4	7	dB
Trans. att. gain (2)	G _{TA MAX2}	Vin4= -60dBm I _L =20mA	33	36	39	dB
Trans. att. gain range (2)	G _{TA MIN2}	Vin4= -60dBm I _L =20mA	47	50	—	dB
Trans. att. idling gain (2)	G _{TA IDL2}	Vin4= -60dBm I _L =20mA	3	6	9	dB
HF receiver						
Rec. gain (1)	G _{FR1}	Vin3= -50dBm I _L =20mA	34	37	40	dB
Rec. gain (2)	G _{FR2}	Vin3= -50dBm I _L =120mA	40	43	46	dB
Rec. distortion	TSP	Vin3= -50dBm I _L =20mA	—	1.5	5.0	%
Rec. max output (1)	V _{SP1}	TSP=5%, I _L =20mA	-10	-7	—	dBm
Rec. max output (2)	V _{SP2}	TSP=5%, I _L =120mA	4	7	—	dBm
Rec. noise	N _{FR}	R _g =2kΩ, I _L =20mA with a CCITT filter	—	—	-60	dBm
Rec. att. gain (1)	G _{RA MAX1}	Vin3= -40dBm I _L =20mA	9	12	15	dB
Rec. att. gain range (1)	G _{RA MIN1}	Vin3= -40dBm I _L =20mA	49	52	—	dB
Rec. att. idling gain (1)	G _{RA IDL1}	Vin3= -40dBm I _L =20mA	-15	-12	-9	dB
Rec. att. gain (2)	G _{RA MAX2}	Vin3= -40dBm I _L =120mA	14	17	20	dB
Rec. att. gain range (2)	G _{RA MIN2}	Vin3= -40dBm I _L =120mA	53	56	—	dB
Rec. att. idling gain (2)	G _{RA IDL2}	Vin3= -40dBm I _L =120mA	-13	-10	-7	dB
Rec. att. volume characteristics	G _{RA VRM}	Vin3= -40dBm I _L =20mA	-4	-2	0	dB

■ Electrical Characteristics (Design Values for Reference) (Ta=25±2°C)

Parameter	Symbol	Condition	Design value	Unit
HS power supply				
HS mode internal reference voltage (1)	V _{IS}	Pin31 high, Pin32 high, I _L =20mA	1.0	V
HS mode internal reference voltage (2)	V _{SPS}	Pin31 high, Pin32 high, I _L =20mA	2.0	V
HS mode internal reference voltage (3)	V _{BGS}	Pin31 high, Pin32 high, I _L =20mA	1.17	V
HS mode AC impedance	Z _{ACS}	Pin31 high, Pin32 high, I _L =20mA	610	Ω

■ Electrical Characteristics (Design Values for Reference) (cont.) (Ta=25±2°C)

Parameter	Symbol	Condition	Design value	Unit
HF power supply				
HF mode internal reference voltage (1)	V _{IF}	Pin31 high, Pin32 low, I _L =20mA	1.0	V
HF mode internal reference voltage (2)	V _{SPF}	Pin31 high, Pin32 low, I _L =20mA	2.0	V
HF mode internal reference voltage (3)	V _{BGF}	Pin31 high, Pin32 low, I _L =20mA	1.17	V
HF mode AC impedance	Z _{ACF}	Pin31 high, Pin32 low, I _L =20mA	610	Ω
Control voltage				
Low level	V _C (L)		- 0.3 to + 0.5	V
High level	V _C (H)		1.0 to 5.0	V

Note) These values are for reference only (not guaranteed values).

■ Mode Control

Pin No.			Description
31	32	15	
HF, HS/MF	HS/MF	REC-CONT	
0	0	0	Transmit MF in the hands-free mode. Trans./rec. att. can be changed according to input level.
0	0	1	Transmit MF in the hands-free mode. Trans./rec. att. is available only in the receiver mode.
0	1	0	Transmit MF in the handset mode.
0	1	1	Transmit MF in the handset mode.
1	0	0	Speech in the hands-free mode
1	0	1	Speech in the hands-free mode. Trans./rec. att. is available only in the receiver mode.
1	1	0	Speech in the handset mode
1	1	1	Speech in the handset mode

Where 0 means connection to GND, and 1 means connection to Pin41(V_{CC1}).

■ ES-42D Package Power Dissipation

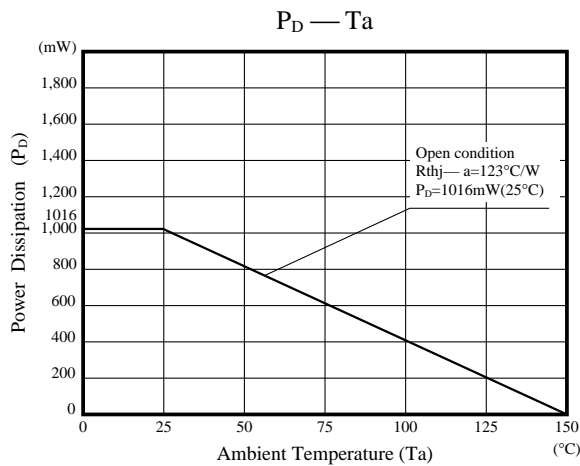

■ Operation in the Hand-free Mode

• Block Diagram

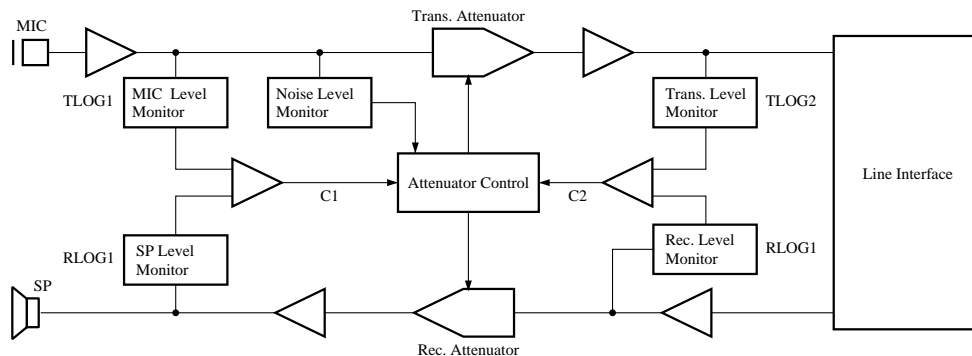

■ Attenuator Control

Input signal				Operation mode
C1	C2	Trans. noise	REC- CONT	
TX	TX	TX	0	Transmitter mode
TX	RX	TX	0	High-speed switching idle mode
RX	TX	TX	0	High-speed switching idle mode
RX	RX	—	0	Receiver mode
TX	TX	noise	0	Low-speed switching idle mode
TX	RX	noise	0	Low-speed switching idle mode
RX	TX	noise	0	Low-speed switching idle mode
—	—	—	1	Receiver mode

C1 : Output comparison between TLOG1 and RLOG1.

C2 : Output comparison between TLOG2 and RLOG2.

■ Trans./Rec. Switching Characteristics

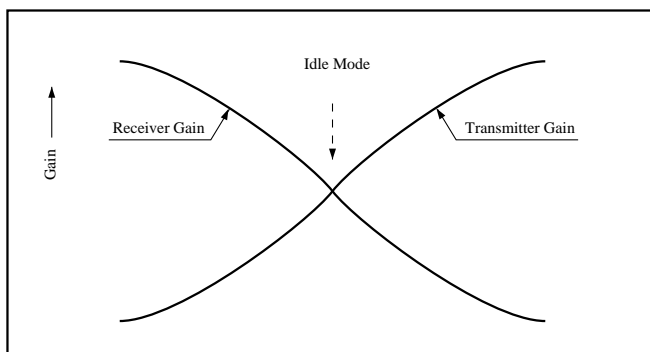

1. Setting

(1) Setting the Line Path

1—1 Setting the DC Characteristics

The AN6175K can be made compatible with local telephone regulations by setting the following characteristics :

1. Gradient of the I_L — V_L characteristics
2. Degree of shifting of the I_L — V_L characteristics

How to set the above characteristics is described below.

1. Setting the gradient of the I_L - V_L characteristics

Referring to Fig.1—1, the resistance of R34 is 27 Ω (standard)as with the current application board.

- If R34's resistance is decreased, the gradient decreases.
- If R34's resistance is increased, the gradient increases.

Also see Fig.1—2.

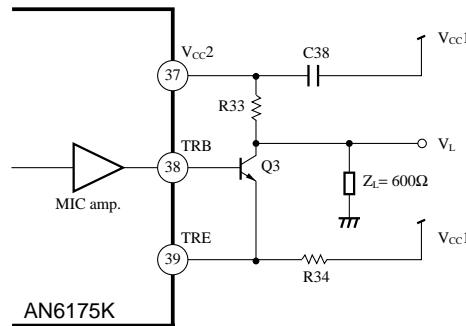

Fig.1—1 Line Output Block Diagram

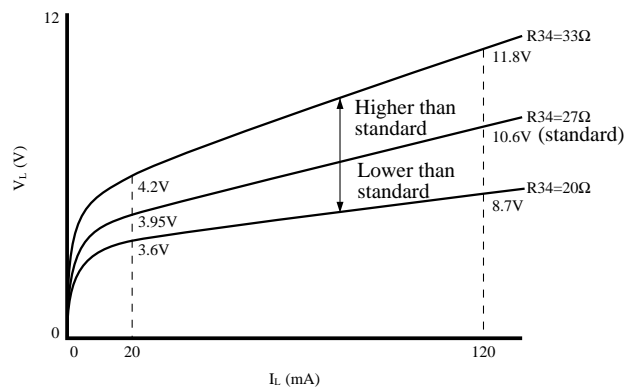

Fig.1—2 I_L — V_L Characteristics

As shown in Fig.1—2, the resistance of R34 determines the gradient of the I_L — V_L characteristics. R34 also affects the gain of the line output. Also see 1—2, Setting the AC Characteristics.

2. Setting the degree of shifting of the I_L-V_L characteristics

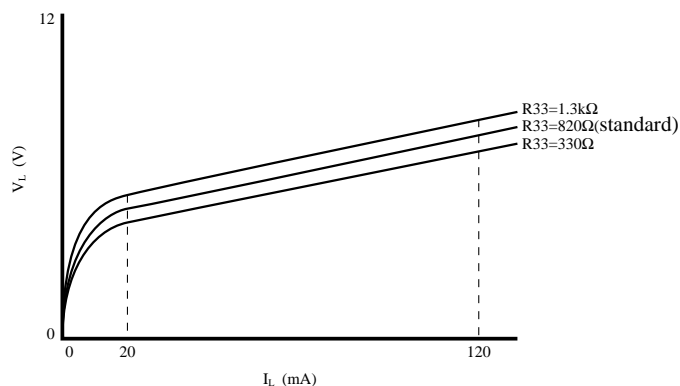

Fig.1—3 I_L-V_L Characteristics

Referring to Figs.1—1 and 1—3, the resistance of R33 is now set to 820Ω(standard).

- If R33's resistance is decreased, the curve shifts downward.
- If R33's resistance is increased, the curve shifts upward.

As shown in Fig.1—3, the resistance of R33 determines the degree of vertical shifting of the I_L-V_L characteristics. R33 also affects the AC characteristics of the line interface.

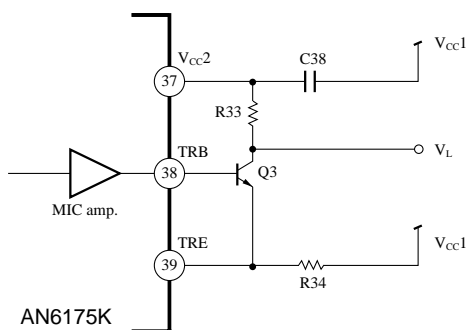

Fig.1—4 Line Output

Referring to Fig.1—4, the AC impedance(Z_{AC})of the line interface is calculated as follows :

$$Z_{AC} = R33/ZQ3$$

If the impedance of transistor Q3 is 2 kΩ($ZQ3=2\text{ k}$), and the resistance of R33 is 820Ω, then Z_{AC} is determined as follows :

$$Z_{AC} = 820//2k = 600\Omega$$

1—2 Setting the AC Characteristics

1. Line output gain adjustment

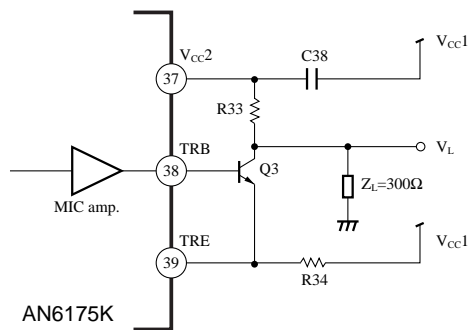

Fig.1—5 Line Output Block Diagram

Use R34 to adjust the line output gain as shown in Fig.1—1.

The line output amplifier gain, $G_{(38)}$, as seen from Pin38, is calculated as follows :

$$G_{(38)} = 20 \log (Z_L/R34)$$

If R34 is 27Ω, $G_{(38)}$ is 21dB.

2. Automatic PAD control adjustment

Automatic PAD control, or APC, is such a function as to automatically adjust transmission gain according to line current (I_L). The gain range of the APC of the AN6175K is 6 dB. The adjustment of the APC means setting the I_L at which the APC starts functioning. The adjustment is done by changing the R_{24}/R_{25} ratio as shown in Fig.2—1.

Under the standard condition($R_{24}=18\text{ k}\Omega$, $R_{25}=12\text{ k}\Omega$), the I_L at which the APC starts functioning(the APC start point)is 45 mA as shown in Fig.2—2.

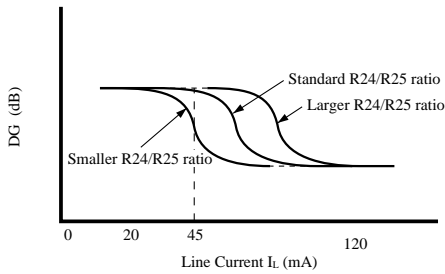

Fig.1—6 Automatic PAD Control

Referring to Fig. 1—6, the APC start point depends on the R_{24}/R_{25} ratio as follows :

- If the ratio increases, the point becomes higher.
- If the ratio decreases, the point becomes lower.

3. Balance network adjustment

The balance network of the AN6175K application board is shown below. Its constants can be adjusted to application needs.

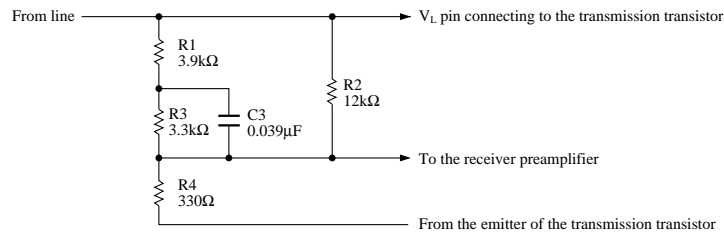

Fig.1—7 Balance Network

(2) Handset(HS)Mode

2—1 Setting the Transmitter System

The block diagram of the transmitter system in the HS mode is shown below.

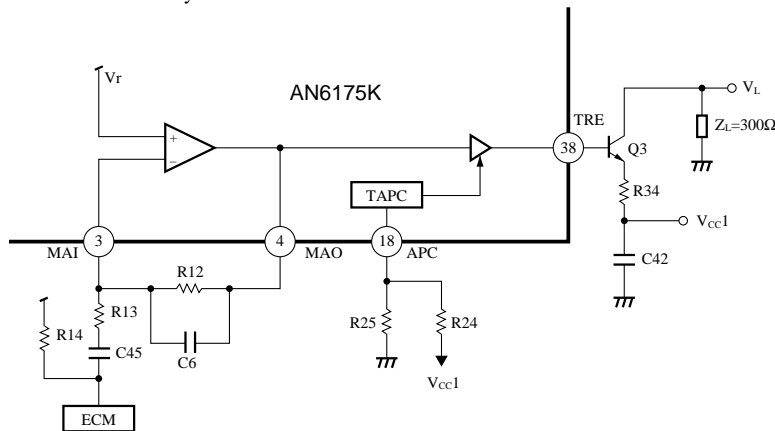
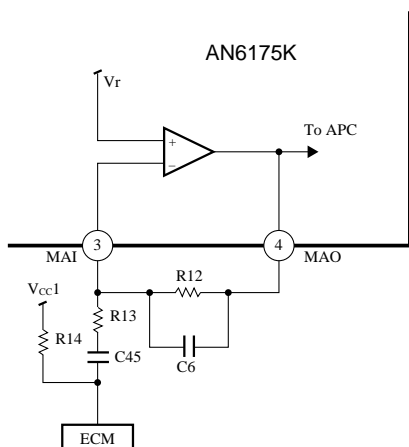

Fig.2—1 HS Mode Transmitter System Block Diagram

As seen from the above diagram, the gain of the transmitter system from ECM to VL in the HS mode is determined by the gain of the MIC preamplifier and the gain of the line output amplifier(21dB). How to adjust the gain/frequency characteristics of the MIC preamplifier is described below.

MIC Preamplifier Gain/Frequency Characteristics Adjustment

The external components, R12, R13, C6, and C45, determine the MIC preamplifier gain/frequency characteristics in the HS mode as shown in Fig. 2—2. R12 and C6 form a low-pass filter, and R13 and C45 form a high-pass filter.



Referring to Fig.2—2, the MIC preamplifier gain, $G_{(HSMIC)}$, is calculated as follows :

$$G_{(HSMIC)} = 20 \log \frac{\{1 / (2\pi f C6)\} // R12}{\{1 / (2\pi f C45)\} + R13} \text{ (dB)}$$

In the standard condition, $R12=R13=10 \text{ k}\Omega$, $C6=102 \text{ pF}$, and $C45 = 0.1\mu\text{F}$.

Fig.2—2 MIC Preamplifier

The HS mode transmitter frequency characteristics are calculated as follows :

- High-band cutoff frequency, $f_{HC}=1/(2\pi C6 \cdot R12)$
- Low-band cutoff frequency, $f_{LC}=1/(2\pi C45 \cdot R13)$

Referring to the above calculations :

- For the low-pass filter, the larger the C6 capacitance, the lower the cutoff frequency, or the smaller the capacitance, the higher the frequency.
- For the high-pass filter, the larger the C45 capacitance, the lower the cutoff frequency, or the smaller the capacitance, the higher the frequency. See Fig.2—3.

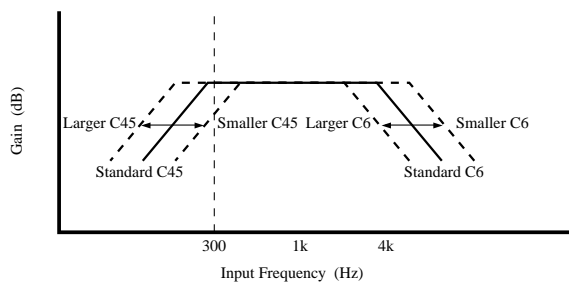

Fig.2—3 HS Mode Transmitter Frequency Characteristics

2-2 Setting the Receiver System

The block diagram of the receiver system in the HS mode is shown below.

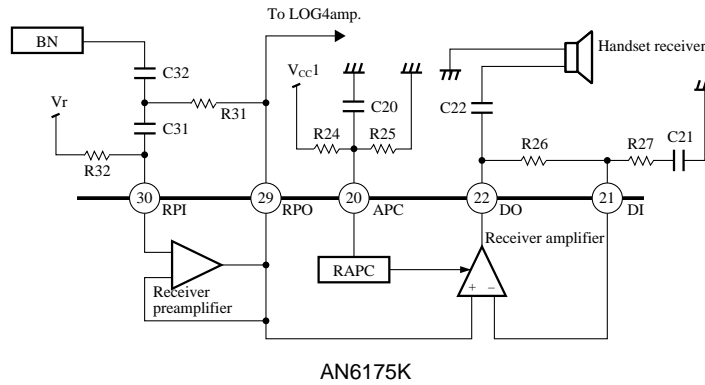

Fig.2-4 HS Mode Receiver System Block Diagram

There are two adjustments for the HS mode receiver system as follows :

1. Set the frequency characteristics of the receiver preamplifier.
2. Adjust the receiver amplifier.

1. Receiver Preamplifier Frequency Characteristics Setting

Fig.2-5 is the block diagram for the receiver preamplifier.

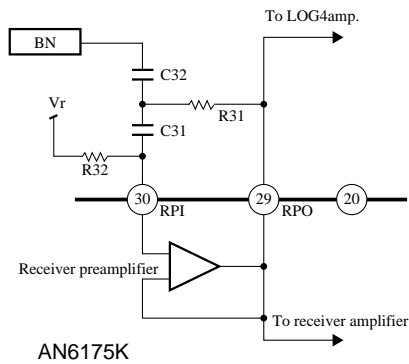

Fig.2-5 Receiver Preamplifier Block Diagram

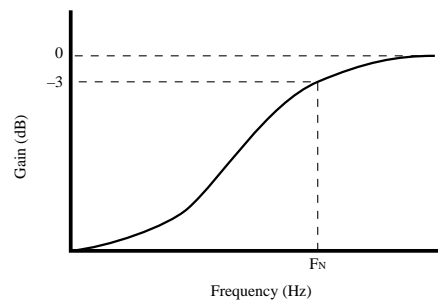

Fig.2-6 HPF Frequency Characteristics

A high-pass filter(HPF)consisting of R31, R32, C31, and C32 blocks external hum noise. The frequency characteristics of the HPF are calculated as follows(see Fig. 2-6) :

$$F_N = \frac{1}{2\pi} \sqrt{\frac{1}{C31 \cdot C32} \times \frac{1}{R31 \cdot R32}}$$

In the standard condition, R31=56 kΩ, R32=220 kΩ, and C31=C32= 0.0047μF.

2. Receiver Amplifier Gain Adjustment

Use R26, R27, and C21 to adjust the receiver amplifier gain as shown in Fig.2-7.

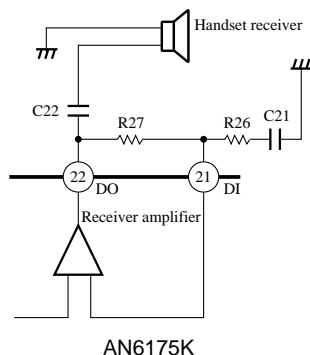

Referring to Fig.2-7, the receiver amplifier gain, $G_{(REC)}$, is calculated as follows :

$$G_{(REC)} = 20 \log \frac{R27}{R26 + \{1/(2\pi f C21)\}} \quad (\text{dB})$$

In the standard condition, R26=1 kΩ, R27=100 kΩ, and C21=10μF.

Fig.2-7 Receiver Amplifier

(3) Hands-Free (HF) Mode

3-1 Setting the Transmitter System

The block diagram of the transmitter system in the HF mode is shown below.

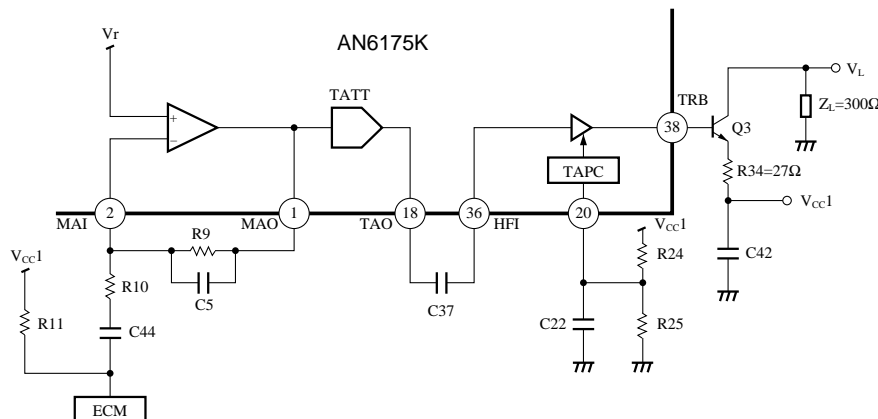

Fig.3-1 HF Mode Transmitter System Block Diagram

As seen from the above diagram, the gain of the transmitter system from ECM to VL in the HF mode is determined by the gains of the MIC preamplifier, transmitter attenuator(T ATT), and line output amplifier. The gain of the T ATT is 0 dB, and the gain of the line output amplifier is 21 dB(see 1-2, Setting the AC Characteristics). How to adjust the gain of the MIC preamplifier is the same as that in the HS mode. The gain, $G_{(HSMIC)}$, is calculated as follows :

$$G_{(HSMIC)} = 20 \log \frac{\{1/(2\pi f C5)\} // R9}{\{1/(2\pi f C44)\} + R10} \quad (\text{dB})$$

In the standard condition, R9=26 kΩ, R10=10 kΩ, C5=102 pF, and C44=0.1 μF.

3-2 Setting the Receiver System

The block diagram of the receiver system in the HF mode is shown below.

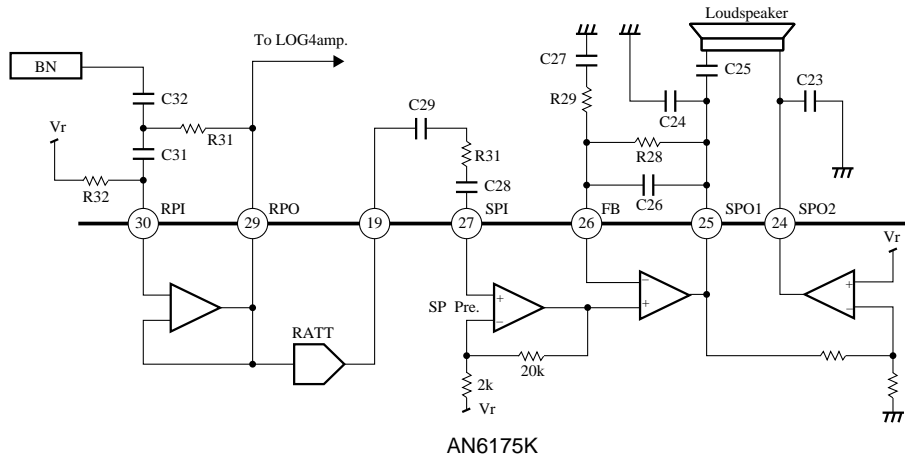

Fig.3-2 HF Mode Receiver System Block Diagram

There are two settings for the HF mode receiver system as follows :

- Set the gain of the receiver preamplifier.
- Set the gain of the loudspeaker amplifier.

Setting of the receiver preamplifier gain is the same as that in the HS mode. How to set the loudspeaker amplifier gain is described below.

The loudspeaker amplifier gain, $G_{(SP)}$, is calculated as follows :

$$G_{(SP)} = 20 \log \frac{R28 // \{1/(2\pi f C26)\}}{R29 + \{1/(2\pi f C27)\}} + 6 \quad (\text{dB})$$

Note : 6 dB is added for the purpose of BTL configuration.

In the standard condition, $R28=R29=20 \text{ k}\Omega$, $C26=100 \text{ pF}$, and $C27=47\mu\text{F}$.

(4) MF Mode

4-1 Setting the MF Signal Gain

Fig. 4-1 shows how the MF signal flows.

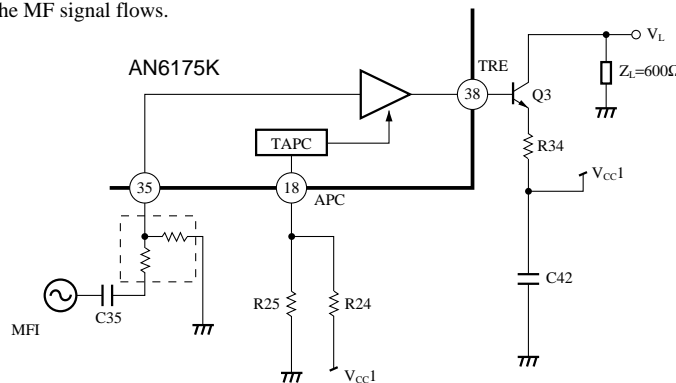

Fig.4-1 MF Signal Flow

In the standard condition, the MF signal gain, $G(\text{MF})$, is equal to the line output gain, that is, 21 dB. To adjust the MF signal gain, use a proper resistor combination as indicated in a dotted box in Fig. 4-1.

■ Detailed Pin Descriptions

Pin No.	Symbol	Description	Equivalent circuit
1	MAO(HF)	<p>[MIC preamplifier output in the HF mode]</p> <p>Amplified HF mode transmitter signals are output from this pin through C7(0.1 μF) and R15(5.1 kΩ) to pin 7 to become the LOG amp.1 input. The output impedance, Z_{out}=50Ω.</p>	
2	MAI(HF)	<p>[MIC preamplifier input in the HF mode]</p> <p>HF mode transmitter signals are input from ECM. Use R9 and R10 to adjust the transmitter signal gain, and use C3 and C44 to adjust the frequency characteristics.</p>	
3	MAI(HS)	<p>[MIC preamplifier input in the HS mode]</p> <p>HS mode transmitter signals are input from the handset MIC. Use R12 and R13 to adjust the transmitter signal gain, and use C6 and C45 to adjust the frequency characteristics.</p>	
4	MAO(HS)	<p>[MIC preamplifier output in the HS mode]</p> <p>Amplified HS mode transmitter signals are output from this pin. The output impedance, Z_{out} = 1 kΩ.</p>	
5	TND	<p>[Noise detecting circuit control]</p> <p>Turns ON or OFF the background-noise detecting circuit in the HS mode. The circuit turns ON if this pin is grounded through C7(SW7 to a), and turns OFF if this pin is grounded directly(SW7 to b).</p>	

■ Detailed Pin Descriptions(cont.)

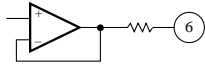
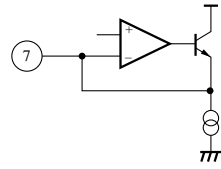
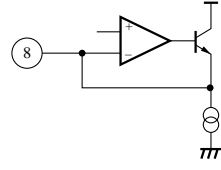
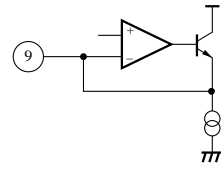
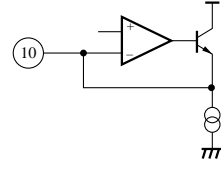
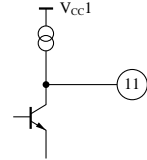
Pin No.	Symbol	Description	Equivalent circuit
6	TVR	[Noise detecting circuit reference] This pin must be grounded through C8 (22 μ F).	
7	TLI1	[LOG amp.(1)input(from MIC amp. output)] This pin connects through C9(0.1 μ F)and R15(5.1 k Ω)to the MIC amp. output.	
8	TLI2	[LOG amp.(2)input(from hands-free control output)] This pin connects through C10(0.1 μ F)and R16(5.1 k Ω)to the HF control output.	
9	RLI1	[LOG amp.(4)input(from receiver preamp. output)] This pin connects through C11(0.1 μ F)and R17(5.1 k Ω)to the receiver preamp. output.	
10	RLI2	[LOG amp.(3)input(from loudspeaker amp. output)] This pin connects through C12(0.1 μ F)and R18(5.1 k Ω)to the loudspeaker amp. output.	
11	TLO1	[LOG amp.(1)output] Outputs amplified MIC amp. output. Grounded through C13(2.2 μ F). The attack recovery time of the attenuator changes with the capacitance of C13.	

■ Detailed Pin Descriptions(cont.)

Pin No.	Symbol	Description	Equivalent circuit
12	TLO2	<p>[LOG amp.(2)output]</p> <p>Outputs the amplified hands-free control output. Grounded through C14(2.2 μF). The attack recovery time of the attenuator changes with the capacitance of C14.</p>	
13	RLO1	<p>[LOG amp.(3)output]</p> <p>Outputs the amplified receiver preamp. output. Grounded through C15(2.2 μF). The attack recovery time of the attenuator changes with the capacitance of C15.</p>	
14	RLO2	<p>[LOG amp.(4)output]</p> <p>Outputs the amplified loudspeaker amp. output. Grounded through C16(2.2 μF). The attack recovery time of the attenuator changes with the capacitance of C16.</p>	
15	REC-CONT	<p>[Receiver switching]</p> <p>Determines whether the attenuator is to be in the receiver mode or normal mode. If this pin is connected to V_{CC1}(SW3 to b), the receiver mode is selected. If connected to GND(SW3 to a), the normal mode is selected.</p>	
16	RVR	<p>[Receiver att. gain control]</p> <p>An external rheostat circuit connects to this pin to control the receiver attenuator gain.</p>	
17	ATC	<p>[Receiver att. switching control]</p> <p>R22(51 kΩ)and C18(4.7 μF)connect to this pin to adjust the attenuator switching time.</p>	

■ Detailed Pin Descriptions(cont.)

Pin No.	Symbol	Description	Equivalent circuit
18	TAO	<p>[Transmitter att. output(hands-free mode)]</p> <p>The transmitter attenuator outputs transmitter signals in the HF mode from this pin to Pin36 through C37(0.1 μF). The output impedance, $Z_{out}=1\text{ k}\Omega$.</p>	
19	RAO	<p>[Receiver att. output(hands-free mode)]</p> <p>The receiver attenuator outputs receiver signals in the HF mode from this pin through C29(0.1 μF) and R30(10 kΩ) to Pin27 as the loudspeaker preamplifier non-inverse input. The output impedance, $Z_{out}=1\text{ k}\Omega$.</p>	
20	APC	<p>[Auto. PAD current control(handset mode, MF)]</p> <p>The ratio of R24 to R25 as connected to this pin controls the operation point of the automatic PAD.</p>	
21	DI	<p>[Receiver amp. input(-)]</p> <p>Combined R26, R27, and C21 as connected to this pin determine the gain of the receiver amplifier.</p>	
22	DO	<p>[Receiver amp. output]</p> <p>Connects through C22(22μF) to the handset receiver. The output impedance, $Z_{out}=100\text{ }\Omega$.</p>	
23	GND	<p>[Ground]</p> <p>This is the ground pin of the IC.</p>	

■ Detailed Pin Descriptions(cont.)

Pin No.	Symbol	Description	Equivalent circuit
24	SPO2	[Loudspeaker amp.(2)output] Pins24 and 25 form a BTL configuration. The output impedance, $Z_{out}=10\ \Omega$.	
25	SPO1	[Loudspeaker amp.(1)output] Pins24 and 25 form a BTL configuration. Connects through R18 and C12 to pin 10 as the LOG amp.(3)input. The output impedance, $Z_{out}=10\ \Omega$.	
26	FB	[Loudspeaker amp. input(-)] Combined R28, R29, C26, and C27 connect to this pin to adjust the gain and the frequency characteristics of the loudspeaker amplifier. The loudspeaker amplifier is added with another gain of 6 dB because of its BTL configuration.	
27	SPI	[Loudspeaker amp. input(+)] The receiver attenuator output signal is sent from pin 19 to this pin through C28 (coupling capacitor).	
28	VSP	[Loudspeaker amp. power input] The power supply pin for the loudspeaker amplifiers and other output circuits.	
29	RPO	[Receiver preamp. output] Amplified receiver signals are output from this pin through C30(coupling)to Pin9 as the LOG amp.(4)input. Within the IC, the receiver preamplifier output also connects to the receiver amplifier for the HS mode and to the receiver attenuator for the HF mode.	
30	RPI	[Receiver preamp. input] Receiver signals are input from line to this pin through a high-pass filter consisting of R31, C31, and C32. The filter removes hum from receiver signals.	

■ Detailed Pin Descriptions(cont.)

Pin No.	Symbol	Description	Equivalent circuit
31	HS, HF/MF	<p>[Mode switching(handset or hands-free /MF)]</p> <p>This pin must be connected to V_{CC1} for the HS or HF mode(SW2 to a), or to GND for the MF mode (SW2 to b).</p>	
32	HS/HF	<p>[Mode switching(handset/hands-free)]</p> <p>This pin must be connected to V_{CC1} for the HS mode (SW1 to a), or to GND for the HF mode (SW1 to b).</p>	
33	Vr	<p>[Reference for the handset or hands-free mode]</p> <p>The voltage equal to half the V_{CC1} voltage is output.</p>	
34	ST	<p>[Input to the base of the power supply transistor]</p> <p>This pin connects to the base of Q4.</p>	
35	MFI	<p>[MF input]</p> <p>MF signals are input to this pin through C35(0.1μF). The input impedance, $Z_{in}=20\text{ k}\Omega$.</p>	
36	HF1	<p>[From transmitter att. output(hands-free mode)]</p> <p>The transmitter attenuator output is sent from Pin18 to this pin through C37(0.1 μF). The input impedance, $Z_{in}=20\text{ k}\Omega$.</p>	
37	V_{CC2}	<p>[Transmission amp. AC impedance setting]</p> <p>This pin connects to V_{CC1} through C38 (100μF)and to the collector of Q3 (transmission transistor)through R38(330 Ω).</p>	

■ Detailed Pin Descriptions(cont.)

Pin No.	Symbol	Description	Equivalent circuit
38	TRB	<p>[To the base of the transmission transistor]</p> <p>This pin connects to the base of Q3 (transmission transistor).</p>	
39	TRE	<p>[To the emitter of the transmission transistor]</p> <p>This pin connects to the emitter of Q3 (transmission transistor) and R33 to adjust the Q3 gain.</p>	
40	BGR	<p>[Band-gap ref. voltage output]</p> <p>Connects to GND through C39(47 μF).</p>	
41	V _{cc1}	<p>[Power output to the handset and hands-free circuits]</p> <p>The power supply pin for the signal processing circuits.</p>	
42	SOUT	<p>[Hands-free control output]</p> <p>Outputs transmitter monitor signals in the HF mode. Connects through R16 and C10 to LOG amp.(2)input at Pin8.</p>	



LittleDiode supplies new, hard to find or obsolete electronic components and semiconductors all over the world.

With over two million different components listed you are sure to find the part you need.

Feel free to visit us today at our online store:

LittleDiode.com

Looking forward to providing you with the best possible service.