

AN6171

Tone Ringer

Overview

The AN6171 is a tone ringer IC which drives a ceramic sounder or speaker as power supply for IC upon receipt of a call signal from telephone set.

Features

- Wide selection of output tone
Four types of tremolo sounds can be selected by SW₁ and SW₂. Each tremolo sound is generated by I²L divider circuit and mixer circuit.
- Rumbling starting voltage variable
Ringer rumbling starting voltage is made variable with external resistors Rh1 and Rh2.
- Built-in hysteresis circuit
This circuit can prevent malfunction due to power noise, resonance due to dial pulse and malfunction due to howler.
- Built-in time starting circuit
This circuit follows the signal such as Centlex whose nonrumbling time is short.
- High output power by BTL circuit
*1 Howler : Alarm signal when the receiver is off-hook.
*2 Centlex : 0.2-sec interval of call signal.

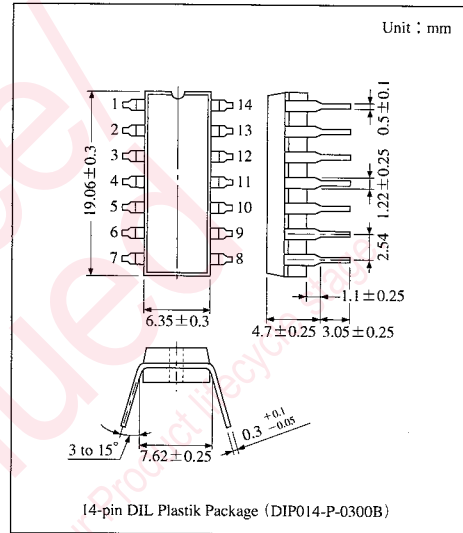

Block Diagram

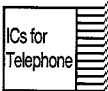
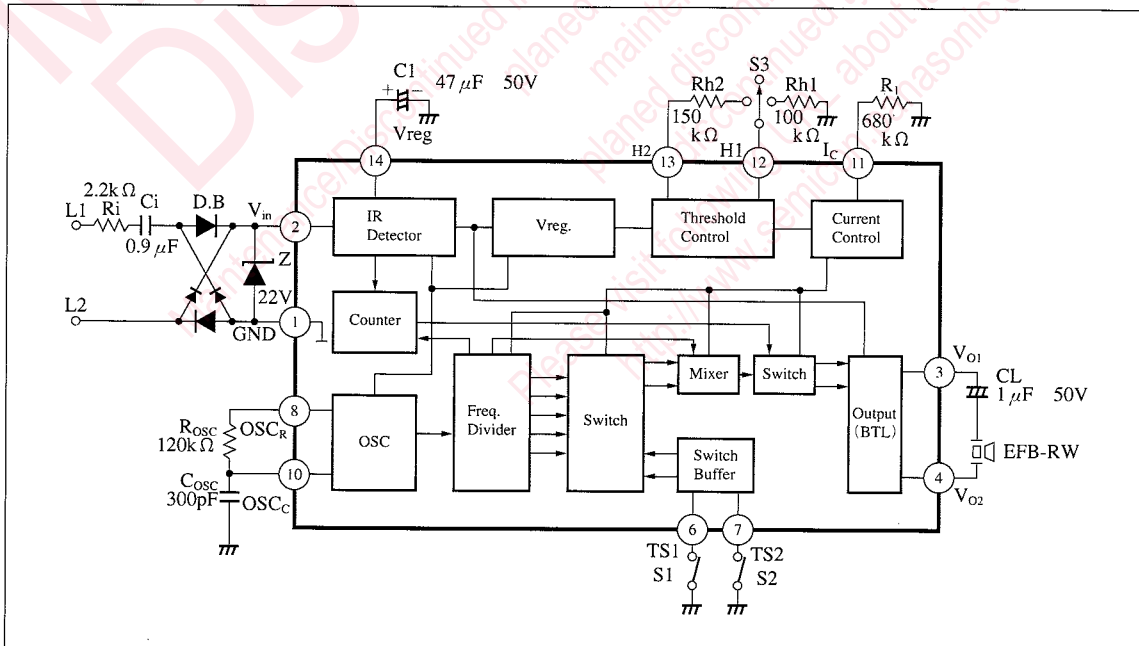

Pin Descriptions

Pin No.	Pin name	Pin No.	Pin name
1	GND	8	Resistor for OSC
2	Input voltage	9	NC
3	Output (1)	10	Capacitor for OSC
4	Output (2)	11	I ² L current control
5	NC	12	Threshold control (1)
6	Tremolo select (1)	13	Threshold control (2)
7	Tremolo select (2)	14	Filter capacitor

Other Requirements for Tone Ringer Circuit Other (Japan)

Parameter	Technical reference and Limit Values	Unit
Call signal supply voltage	75 ⁺⁸ / ₋₁₀	Vrms
Call signal supply frequency	16.6 ± 1	Hz
Electrostatic capacity of telephone	0.9	μF
Impedance of telephone	11 or more	kΩ

Absolute Maximum Ratings (Ta = 25°C)

Parameter	Symbol	Rating	Unit
Supply voltage	V _{CC}	24	V
Power dissipation	P _D	500	mW
Operating ambient temperature	T _{opr}	-30 to +75	°C
Storage temperature	T _{stg}	-55 to +150	°C

Electrical Characteristics (V_{CC} = 24V, Ta = 25°C)

Parameter	Symbol	Condition	typ	Unit
Rumbling starting supply voltage	V _{st}	R _L = ∞	18.5	V
Rumbling continuous supply voltage	V _{con}	R _L = ∞	12	V
Rumbling starting current consumption	I _{st}	R _L = ∞	2.0	mA
Rumbling continuous current consumption	I _{con}	R _L = ∞	1.8	mA
Output frequency (1)	f _w /f ₁ /f ₃	V _{CC} = 22V, Refer to the table.	15.3/1400/980	Hz
Output frequency (2)	f _w /f ₂ /f ₃	V _{CC} = 22V, Refer to the table.	15.3/1225/980	Hz
Output frequency (3)	f _w /f ₃ /f ₄	V _{CC} = 22V, Refer to the table.	15.3/980/820	Hz
Output frequency (4)	f _w /f ₄ /f ₅	V _{CC} = 22V, Refer to the table.	15.3/820/700	Hz
Output voltage	V _{OPP}	V _{CC} = 22V	36	V _{P-P}

Note) Operating supply voltage range : V_{CC(opr)} = 8.5 to 24V

(Table) Measurement Conditions of Output Frequency

Output frequency	Pin	Pin⑥	Pin⑦
(1)		OPEN	OPEN
(2)		OPEN	GND
(3)		GND	OPEN
(4)		GND	GND

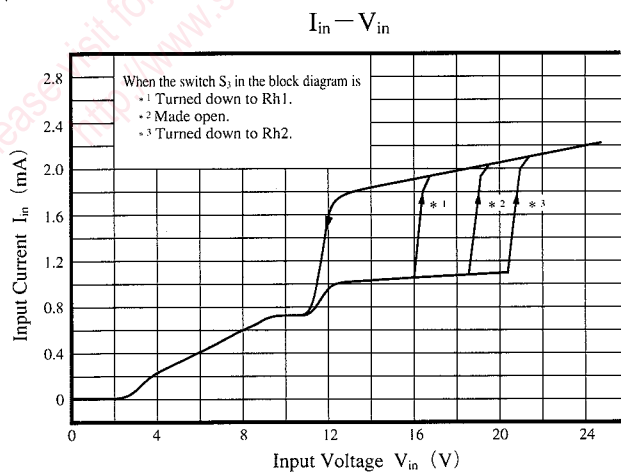

Request for your special attention and precautions in using the technical information and semiconductors described in this book

- (1) If any of the products or technical information described in this book is to be exported or provided to non-residents, the laws and regulations of the exporting country, especially, those with regard to security export control, must be observed.
- (2) The technical information described in this book is intended only to show the main characteristics and application circuit examples of the products. No license is granted in and to any intellectual property right or other right owned by Panasonic Corporation or any other company. Therefore, no responsibility is assumed by our company as to the infringement upon any such right owned by any other company which may arise as a result of the use of technical information described in this book.
- (3) The products described in this book are intended to be used for standard applications or general electronic equipment (such as office equipment, communications equipment, measuring instruments and household appliances).
Consult our sales staff in advance for information on the following applications:
 - Special applications (such as for airplanes, aerospace, automobiles, traffic control equipment, combustion equipment, life support systems and safety devices) in which exceptional quality and reliability are required, or if the failure or malfunction of the products may directly jeopardize life or harm the human body.
 - Any applications other than the standard applications intended.
- (4) The products and product specifications described in this book are subject to change without notice for modification and/or improvement. At the final stage of your design, purchasing, or use of the products, therefore, ask for the most up-to-date Product Standards in advance to make sure that the latest specifications satisfy your requirements.
- (5) When designing your equipment, comply with the range of absolute maximum rating and the guaranteed operating conditions (operating power supply voltage and operating environment etc.). Especially, please be careful not to exceed the range of absolute maximum rating on the transient state, such as power-on, power-off and mode-switching. Otherwise, we will not be liable for any defect which may arise later in your equipment.
 - Even when the products are used within the guaranteed values, take into the consideration of incidence of break down and failure mode, possible to occur to semiconductor products. Measures on the systems such as redundant design, arresting the spread of fire or preventing glitch are recommended in order to prevent physical injury, fire, social damages, for example, by using the products.
- (6) Comply with the instructions for use in order to prevent breakdown and characteristics change due to external factors (ESD, EOS, thermal stress and mechanical stress) at the time of handling, mounting or at customer's process. When using products for which damp-proof packing is required, satisfy the conditions, such as shelf life and the elapsed time since first opening the packages.
- (7) This book may be not reprinted or reproduced whether wholly or partially, without the prior written permission of our company.



LittleDiode supplies new, hard to find or obsolete electronic components and semiconductors all over the world.

With over two million different components listed you are sure to find the part you need.

Feel free to visit us today at our online store:

LittleDiode.com

Looking forward to providing you with the best possible service.