

TD-SCDMA Radio Chipset Block Diagram for Handset Application

China option for 3G cellular phone is the TD-SCDMA system. A detailed handset transceiver diagram is presented showing MAX2361 as the transmit IC, the MAX2291 as the power amplifier (PA), and the MAX2388 and MAX2309 form the receiver. A VCO buffer amplifier is used to provide isolation and maintains a clean LO signal.

Overview

TD-SCDMA is the third-generation (3G) cellular phone standard currently under development in China. In November 1999, the TD-SCDMA standard was adopted by the ITU as one of the options in the 3GPP mobile communication standard.

TD-SCDMA combines time-division duplex (TDD) and CDMA with up-link (reverse-link) synchronization, a software radio, and a smart antenna, to increase channel capacity and improve bandwidth efficiency.

In the radio section of the handset, the TD-SCDMA radio section requires fast switching time, high dynamic range, and high linearity in both the transmitter and receiver sections. Maxim's chipset delivers the highest performance, the smallest implementation size, and the least expensive radio solution available in the TD-SCDMA handset market. The following block diagram shows a typical application.

Transmitter

The MAX236X is a complete quadrature transmitter, including a quadrature modulator, variable-gain IF and RF amplifiers, an image-rejecting upconverting mixer, a dual RF and IF synthesizer, and a dual-band power amplifier (PA) driver amplifier. It is the ideal transmitter for TD-SCDMA because of these features:

- Output power of +8dBm with excellent ACPR
- A 100dB power-control range
- Dual integer-N synthesizers for IF and RF
- An image-reject upconverting mixer, which saves one SAW filter

- Power-supply current dropping as the RF output power is reduced
- Low-noise power during the power-down mode
- Availability in a 48-pin QFN package (7mm x 7mm)

Power Amplifier

The MAX229X is a linear amplifier optimized for TD-SCDMA application. It can deliver +26dBm output power with 30% power-added efficiency (PAE) and 37dBc ACLR1.

Receivers

The MAX2388 includes a low-noise amplifier (LNA), a downconverter, and a local oscillator (LO) buffer amplifier. Requiring ultra-low current consumption (9.9mA), the device is ideal for TD-SCDMA application. The LNA delivers fixed gains of 15dB and -3dB, and it has a 1.7dB noise figure (NF) and +4.2dBm IIP3 at high-gain mode. The mixer is also optimized for high linearity and low noise with two gain steps. Even with 3dB filter insertion loss, the total cascade NF can be as low as 2.3dB. The LO buffer provides excellent isolation and adequate amplification. This feature enables the system to have single RF-LO to drive both the transmitter and the receiver. The device is available in an ultra-small (3mm x 3mm) 12-pin QFN package.

The MAX2309 is an IF receiver designed for the single-band and single-mode CDMA-based cellular phone system. The input frequency range is optimized from 70MHz to 300MHz. A variable-gain amplifier (VGA) and an I/Q demodulator make up the signal path. The device features guaranteed +2.7V operation, a dynamic range of more than 110dB, and high input IP3 (-33dBm at 35dBm gain, +1.7dBm at -35dBm). In addition to demodulation, the MAX2309 includes an oscillator, a synthesizer, and an LO buffer to form a self-contained IF subsystem. The device will be able to provide the IF-LO to drive the transmitter's modulator. The MAX2309 is available in a small, 28-pin, QFN package measuring only 5mm by 5mm.

The MAX2472 is a high-isolation dual-channel VCO buffer amplifier. It is optimized for a frequency range from 500MHz to 2500MHz. The high isolation (49dB) minimizes the transmitting modulation signal to pull VCO frequency. The MAX2472 also includes a shutdown pin, making it ideal for a TDD system such as TD-SCDMA.

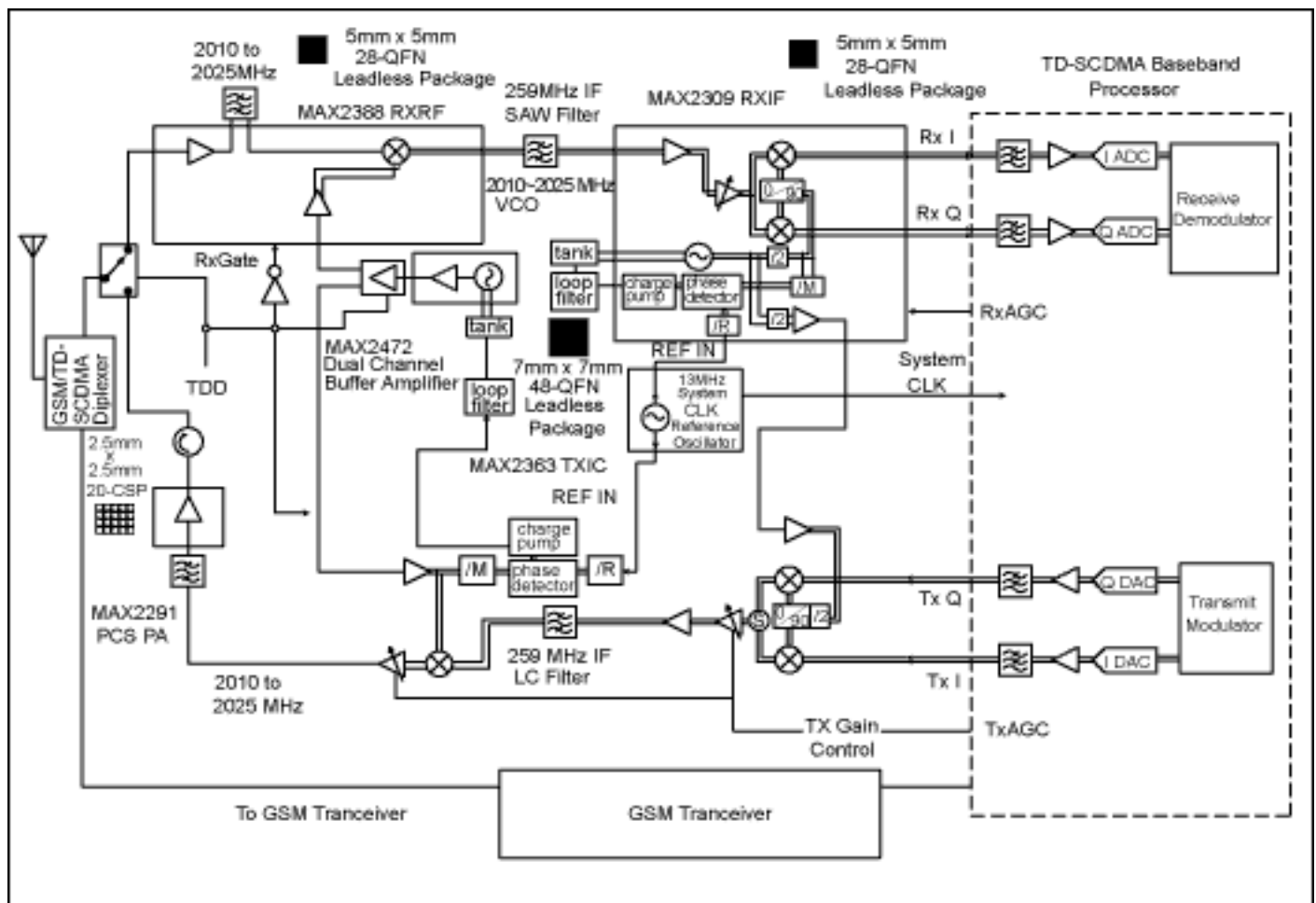

TD-SCDMA/GSM dual-mode transceiver reference design block diagram, Rev A

June 2001

More Information

MAX2309: [QuickView](#) -- [Full \(PDF\) Data Sheet](#) -- [Free Samples](#)

MAX2361: [QuickView](#) -- [Free Samples](#)

MAX2388: [QuickView](#) -- [Full \(PDF\) Data Sheet](#) -- [Free Samples](#)

MAX2472: [QuickView](#) -- [Full \(PDF\) Data Sheet](#) -- [Free Samples](#)

This datasheet has been downloaded from:

www.DatasheetCatalog.com

Datasheets for electronic components.



LittleDiode supplies new, hard to find or obsolete electronic components and semiconductors all over the world.

With over two million different components listed you are sure to find the part you need.

Feel free to visit us today at our online store:

LittleDiode.com

Looking forward to providing you with the best possible service.